



- (51) **International Patent Classification:**  
*E21B 33/12* (2006.01) *C09K 8/02* (2006.01)
- (21) **International Application Number:**  
PCT/US2014/072204
- (22) **International Filing Date:**  
23 December 2014 (23.12.2014)
- (25) **Filing Language:** English
- (26) **Publication Language:** English
- (71) **Applicant:** HALLIBURTON ENERGY SERVICES, INC. [US/US]; 3000 N. Sam Houston Parkway E., Houston, Texas 77032-3219 (US).
- (72) **Inventors:** GALINDO, Kay Ann; 12334 Browning Dr., Montgomery, Texas 77356 (US). DEVILLE, Jay Paul; 23703 Blakeley Trails Ct., Spring, Texas 77386 (US).
- (74) **Agent:** TUMEY, Corey S.; P.O. Box 22188, Houston, Texas 77227-2188 (US).
- (81) **Designated States** (unless otherwise indicated, for every kind of national protection available): AE, AG, AL, AM, AO, AT, AU, AZ, BA, BB, BG, BH, BN, BR, BW, BY,

BZ, CA, CH, CL, CN, CO, CR, CU, CZ, DE, DK, DM, DO, DZ, EC, EE, EG, ES, FI, GB, GD, GE, GH, GM, GT, HN, HR, HU, ID, IL, IN, IR, IS, JP, KE, KG, KN, KP, KR, KZ, LA, LC, LK, LR, LS, LU, LY, MA, MD, ME, MG, MK, MN, MW, MX, MY, MZ, NA, NG, NI, NO, NZ, OM, PA, PE, PG, PH, PL, PT, QA, RO, RS, RU, RW, SA, SC, SD, SE, SG, SK, SL, SM, ST, SV, SY, TH, TJ, TM, TN, TR, TT, TZ, UA, UG, US, UZ, VC, VN, ZA, ZM, ZW.

- (84) **Designated States** (unless otherwise indicated, for every kind of regional protection available): ARIPO (BW, GH, GM, KE, LR, LS, MW, MZ, NA, RW, SD, SL, ST, SZ, TZ, UG, ZM, ZW), Eurasian (AM, AZ, BY, KG, KZ, RU, TJ, TM), European (AL, AT, BE, BG, CH, CY, CZ, DE, DK, EE, ES, FI, FR, GB, GR, HR, HU, IE, IS, IT, LT, LU, LV, MC, MK, MT, NL, NO, PL, PT, RO, RS, SE, SI, SK, SM, TR), OAPI (BF, BJ, CF, CG, CI, CM, GA, GN, GQ, GW, KM, ML, MR, NE, SN, TD, TG).

**Published:**

- with international search report (Art. 21(3))
- with amended claims (Art. 19(1))

WO 2016/105394 A1

(54) **Title:** FLUORINATED PACKER FLUIDS

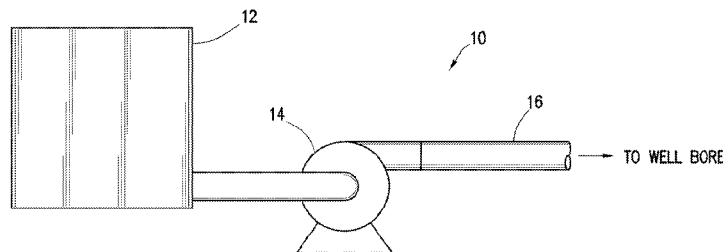

FIG. 1

(57) **Abstract:** Methods and systems of treating a well are provided. A method comprises providing a packer fluid comprising a fluorinated oil; and introducing the packer fluid into a wellbore. The method further comprises introducing the packer fluid into the wellbore may further comprise introducing the packer fluid into a volume above a packer and inside a casing.

## FLUORINATED PACKER FLUIDS

### BACKGROUND

[0001] Methods of using packer fluids and, more particularly, methods of using solids free packer fluids comprising a fluoruous oil in well operations are provided.

5 [0002] Packer fluids may be used during drilling and/or completion of a wellbore and may serve a variety of functions. In drilling operations, a packer fluid may be introduced and allowed to remain in the annulus between the casing and the tubing and may be disposed above a packer. The packer fluid may be used to provide hydrostatic pressure in order to lower the differential pressure across a sealing element in the wellbore, may lower the  
10 differential pressure in the wellbore and casing to prevent collapse, and may protect metals and elastomers from corrosion.

[0003] Packer fluids may also be used in well completion, either prior to or subsequent to the start of production. The packer fluids may be placed in the annulus between the tubing and the casing and may be disposed above a packer. Typically, the  
15 packer fluids may be of a sufficient density to control a producing formation, be resistant to viscosity changes over an extended period of time, and be noncorrosive to wellbore components and equipment.

[0004] Typical packer fluids may comprise brines. Problems with brines may include high thermal conductivity and the potential for corrosion of well components. Packer  
20 fluids comprising a high thermal conductivity may allow for heat transfer to and from elements within the wellbore. This may result in problems during production, in particular for formations that comprise bituminous materials, as the cooling of said materials may allow them to harden and damage well equipment. Further, brines can corrode well components and equipment over time resulting in increased operating expenses as well as  
25 increased downtime should the corrosion severely damage the equipment and require replacement.

**BRIEF DESCRIPTION OF THE DRAWINGS**

[0005] These drawings illustrate certain aspects of some of the examples of the present method and should not be used to limit or define the method.

[0006] FIG. 1 illustrates surface equipment that may be used in the placement of a packer fluid in a wellbore in accordance with certain examples.

[0007] FIG. 2 illustrates the placement of a packer fluid in a wellbore in accordance with certain examples.

## DETAILED DESCRIPTION

[0008] Methods of using packer fluids and, more particularly, methods of using solids free packer fluids comprising a fluoruous oil in well operations are provided.

[0009] The packer fluids may comprise a fluoruous oil. Alternatively, the packer fluids may comprise an invert emulsion comprising a fluoruous oil external phase, an aqueous or nonaqueous internal phase, and optionally, a fluoruous surfactant and/or a weighting agent(s). Except for the optional addition of weighting agents, the packer fluids described herein may be solids free packer fluids. Advantageously, the packer fluids may be used in applications that comprise a broad range of densities. Further advantageously, the packer fluids may be capable of withstanding relatively high temperatures (e.g., temperatures greater than 650°F). Further, the packer fluids may, in some examples, be salt-free and thus do not possess the risk of well component corrosion that may be present in formulations using brines or other salt containing fluids. Finally, the packer fluids possess low thermal conductivity; therefore, the packer fluids resist the transfer of heat, both to and from other materials. Thus, while the packer fluids may be suitable for a variety of well conditions and subterranean formation types, they may be particularly suitable for use in wells requiring high fluid densities, high temperature resistance, operations where corrosion may be an issue, or operations in which heat transfer between materials is to be avoided (e.g., operations where bituminous materials may be present).

[0010] The packer fluids may comprise a fluoruous oil. Any fluoruous organic liquid may be suitable for use as the fluoruous oil. The fluoruous oil comprises carbon and at least one fluorine functional group. The fluoruous oil may be polyfluorinated or perfluorinated. The fluoruous oil may comprise functional groups other than fluorinated or hydrocarbon-containing groups. Without limitation, examples of the fluoruous oil may include perfluoropolyethers ("PFPE"), perfluoroamines ("PFA"), perfluorohydrocarbons, polyfluorinated ethers, polyfluorinated amines, polyfluorinated hydrocarbons, and their derivatives. Examples of commercially available fluoruous oils include KRYTOX<sup>™</sup>, available from Dupont of Wilmington, Delaware; FOMBLIN<sup>®</sup>, available from Solvay Plastics in Alpharetta, Georgia; and DEMNUM<sup>®</sup>, available from Daikin Company in Orangeburg, New York.

[0011] The packer fluid may be essentially solids free. As defined herein, solids free means a packer fluid comprising only fluids, which may, in some examples, comprise salt(s) at a concentration below the solubility limit of the salt(s) under wellbore conditions. In some examples, weighting additives, which may comprise solids, may be used to increase the

density of the packer fluids. It is to be understood that weighting additives are optional and their use is not critical for the functionality of the packer fluid formulations described herein.

[0012] The fluoruous oil may comprise 100% of the packer fluid with no additives or, in other words, the packer fluid may consist of the fluoruous oil. In other examples, the fluoruous oil may be used with additives such as density modifying additives (e.g., weighting agents). In alternative examples, an invert emulsion comprising the fluoruous oil may be used. The fluoruous oil may be present in the invert emulsion in an external phase to internal phase ratio of about 50:50 to about 99:1. For example, the fluoruous oil may be present in the invert emulsion in an external phase to internal phase ratio of about 60:40, about 70:30, about 80:20, about 90:10, etc. With the benefit of this disclosure one of ordinary skill in the art should recognize the appropriate amount of fluoruous oil for a chosen application.

[0013] Optionally, the packer fluid may comprise an invert emulsion. In examples utilizing an invert emulsion, the external phase may comprise the fluoruous oil. The internal phase may comprise an aqueous or nonaqueous fluid. In examples comprising an aqueous fluid internal phase, the aqueous fluid may be any such aqueous fluid suitable for use. The aqueous fluid may be from any source provided that it does not contain an excess of compounds that may undesirably affect other components in the packer fluids, for example. The aqueous fluid may comprise fresh water or salt water. Salt water generally may include one or more dissolved salts therein and may be saturated or unsaturated as desired for a particular application. Seawater or brines may be suitable for use in some applications.

[0014] In some examples, the internal phase may be a salt-free non-chloride containing internal phase. An example of a salt-free non-chloride containing internal phase may be a salt-free non-chloride containing aqueous fluid or nonaqueous fluid. The salt-free non-chloride containing internal phase may comprise a mixture. For example, the salt-free non-chloride containing internal phase may comprise a mixture of a polyol in water. The polyol may make up any percentage of the mixture in the range of about 20% to about 99% by weight of the mixture, for example the polyol may comprise about 20%, about 40%, about 60%, about 80%, or about 99% by weight of the mixture. An example of a salt-free non-chloride containing aqueous fluid comprising a polyol may be a mixture of glycerol in water. In some examples, the internal phase may comprise a nonaqueous fluid. For example, the internal phase may comprise a 100% polyol fluid. As noted above, in some examples, the nonaqueous fluid may be a salt-free non-chloride containing nonaqueous fluid. An example of a salt-free non-chloride containing nonaqueous fluid may be a 100% glycerol fluid. Further examples of suitable polyols may include, but are not limited to glycerine, ethylene glycol, propylene glycol, polyethylene glycol, polypropylene glycol, diethylene glycol, and

sugar alcohols. Additionally sugars such as glucose, fructose, mannitol, sucrose, and xylose may be substituted for the polyols; as may carboxylic acids such as citric acid, tartaric acid, and malic acid; amino acids such as glycine and alanine; nitrogen compounds such as urea; and more generally any organic capable of reducing the water activity of the aqueous phase.

5 [0015] The internal phase may be present in the invert emulsion examples in an external phase to internal phase ratio of about 50:50 to about 99:1. With the benefit of this disclosure one of ordinary skill in the art should recognize the appropriate type and ratio for the internal phase of the invert emulsions examples for a chosen application.

[0016] The packer fluids may comprise a fluorosurfactant. Fluorosurfactants are  
10 synthetic organofluorine chemical compounds that may comprise multiple fluorine atoms. They may be polyfluorinated or perfluorinated. Without limitation, some fluorosurfactants may be used to lower the surface tension of the internal phase in examples utilizing an invert emulsion. The fluorosurfactants may have a fluorinated tail and a hydrophilic head. Without  
15 limitation, examples of fluorosurfactants may include perfluorooctanesulfonic acid, perfluorooctanoic acid, perfluorononanoic acid, perfluorobutanesulfonic acid, tetrafluoropropanol, octafluoropentanol, dodecafluoroheptanol, fluorinated telomer alcohols, fluorophosphates, salts of fluorophosphates, fluorosulfonates, salts of fluorosulfonates, and combinations thereof. The fluorosurfactant may be present in the packer fluids in an amount  
20 in the range of from about 0.01% to about 10% by weight of the packer fluid. More particularly, the fluorosurfactant may be present in an amount ranging between any of and/or including any of about 0.01%, about 0.1%, about 1%, about 2%, about 4%, about 6%, about 8%, or about 10% by weight of the packer fluid. A commercial example of a fluorosurfactant is FLUOROLINK<sup>®</sup> F10 available from Solvay Plastics in Alpharetta, Georgia. One of  
25 ordinary skill in the art, with the benefit of this disclosure, should recognize the appropriate type and amount of fluorosurfactant to include for a chosen application.

[0017] The packer fluids may optionally comprise a fluid loss additive. Fluid loss  
additives, e.g., polymers, may be included in the packer fluids. Amongst other reasons, fluid  
loss additives may be included in the packer fluids to control fluid loss to the formation.  
Without limitation, examples of fluid loss additives may include perfluoropolystyrene,  
30 perfluoropolytert-butylstyrene, perfluoropolymethylstyrene acrylates, polytetrafluoroethylene, perfluoropolyalkylethyl acrylates, perfluoropolyalkylethyl methacrylates, perfluoropolyalkyl acrylates, perfluorinated polyamides, perfluoropolyacrylamides, polytetrafluoroethylene-polyamides, fluorinated polyamides, perfluorinated tall oil fatty amides, perfluoropolystyrenebutadienes, perfluoropolyethylene  
35 ethene/butene copolymer, and the like. The fluid loss additives may be included in the packer

fluids in any amount sufficient to control loss of the packer fluids (or subsequently pumped fluids) to the formation. For example, the fluid loss additives may be present in the packer fluids in an amount in the range of from about 0% to about 10% by weight of the packer fluid. More particularly, the fluid loss additives may be present in an amount ranging  
5 between any of and/or including any of about 0%, about 0.1%, about 1%, about 2%, about 4%, about 6%, about 8%, or about 10% by weight of the packer fluid. One of ordinary skill in the art, with the benefit of this disclosure, should recognize the appropriate type and amount of fluid loss additive to include for a chosen application.

[0018] The packer fluids may optionally comprise a corrosion inhibitor. The  
10 fluorous oil generally provides sufficient corrosion resistance without the use of corrosion inhibitors, however in some formations additional corrosion inhibition may be desired. Corrosion inhibitors may be used to shield well components and equipment from corrosion. Without limitation, examples of corrosion inhibitors include perfluoropolystyrene, perfluoropolytert-butylstyrene, perfluoropolymethylstyrene acrylates,  
15 polytetrafluoroethylene, and the like. Both fluorous-based and nonfluorous-based corrosion inhibitors may be used. The corrosion inhibitors may be included in the packer fluids in any amount sufficient to prevent corrosion of well components and equipment. For example, the corrosion inhibitors may be present in the packer fluids in an amount in the range of from about 0 % to about 10% by weight of the packer fluid. More particularly, the corrosion  
20 inhibitors may be present in an amount ranging between any of and/or including any of about 0%, about 0.1%, about 1%, about 2%, about 4%, about 6%, about 8%, or about 10% by weight of the packer fluid. One of ordinary skill in the art, with the benefit of this disclosure, should recognize the appropriate type and amount of corrosion inhibitor to include for a chosen application.

[0019] The packer fluids may optionally comprise a viscosifier. The viscosifier may  
25 be included to optimize fluid rheology and to stabilize the suspension. Without limitation, examples of viscosifiers include perfluorinated polyamides, perfluoropolyacrylamides, polytetrafluoroethylene -polyamides, fluorinated polyamides, perfluorinated tall oil fatty amides, fluorinated polysaccharides, perfluorinated fatty acids, perfluorinated tall oil fatty  
30 acids, perfluoropolystyrenebutadienes, perfluoropolyethylene ethene/butene copolymer, and the like. Viscosifiers may be included in the packer fluids in any amount sufficient to viscosify the packer fluids to the desired degree. For example, the viscosifiers may be present in the packer fluids in an amount in the range of from about 0 % to about 10% by weight of the packer fluid. More particularly, the viscosifiers may be present in an amount  
35 ranging between any of and/or including any of about 0%, about 0.1%, about 1%, about 2%,

about 4%, about 6%, about 8%, or about 10% by weight of the packer fluid. One of ordinary skill in the art, with the benefit of this disclosure, should recognize the appropriate type and amount of viscosifier to include for a chosen application.

[0020] Weighting agents are typically materials that weigh more than water and may be used to increase the density of the packer fluids. By way of example, weighting agents may have a specific gravity of about 2 or higher (*e.g.*, about 2, about 4, etc.). Examples of weighting agents that may be used include, but are not limited to, hematite, hausmannite, barite, and combinations thereof. Specific examples of suitable weighting agents include API grade barite. Commercial examples of weighting agents include HI-DENSE<sup>®</sup> weighting agent, BAROID<sup>®</sup> 41 weighting agent, and BARACARB<sup>®</sup> weighting agents; all of which are available from Halliburton Energy Services Inc., Houston, Texas. The weighting agents may be present in the packer fluids in an amount in the range of from about 0 % to about 50% by weight of the packer fluid. More particularly, the weighting agents may be present in an amount ranging between any of and/or including any of about 0%, about 0.1%, about 1%, about 2%, about 4%, about 6%, about 8%, about 10%, about 20%, about 30%, about 40%, or about 50% by weight of the packer fluid. One of ordinary skill in the art, with the benefit of this disclosure, should recognize the appropriate type and amount of weighting agent to include for a chosen application.

[0021] Lost-circulation materials may be included in the packer fluids to, for example, help prevent the loss of fluid circulation into the subterranean formation. Examples of lost-circulation materials include but are not limited to, polytetrafluoroethylene fibers, fluorinated fibers, polytetrafluoroethylene-polyamides, fluorinated polyamides, perfluorinated resins, fluorinated telomers, and the like. Non-fluorous lost-circulation materials such as graphite, nut shells, calcium carbonate, and the like, may also be used if desired. Further examples of lost-circulation materials may include various types of fibers including non-fluorous natural or synthetic fibers. For example, the lost-circulation fiber types may include natural, biopolymers, synthetic, biodegradable, and/or biocompatible fibers. Examples of synthetic fibers may include, but are not limited to, polymers composed of polypropylene, polyaramide, polyester, polyacrylonitrile, and polyvinyl alcohol. Examples of biodegradable fibers may include, but are not limited to, fibers composed of modified cellulose, chitosan, soya, modified chitosan, polycaprolactone, poly(3-hydroxybutyrate), polyhydroxy-alkanoates, polyglycolic acid "PGA", polylactic acid "PLA", polyorthoesters, polycarbonates, polyaspartic acid, polyphosphoesters, soya, or copolymers thereof. Examples of other suitable fibers may include, but are not limited to fibers of cellulose including viscose cellulosic fibers, oil coated cellulosic fibers, and fibers derived



from a plant product like paper fibers; carbon including carbon fibers; melt-processed inorganic fibers including basalt fibers, wollastonite fibers, non-amorphous metallic fibers, ceramic fibers, and glass fibers. The lost-circulation materials may be present in the packer fluids in an amount in the range of from about 0 % to about 20% by weight of the packer fluid. More particularly, the lost-circulation materials may be present in an amount ranging between any of and/or including any of about 0%, about 0.1%, about 1%, about 2%, about 4%, about 6%, about 8%, about 10%, or about 20% by weight of the packer fluid. One of ordinary skill in the art, with the benefit of this disclosure, should recognize the appropriate type and amount of lost circulation material to include for a chosen application.

10 [0022] Those of ordinary skill in the art should appreciate that examples of the packer fluids generally should have a density suitable for a particular application. By way of example, the packer fluids may have a density in the range of from about 10 pounds per gallon ("lb/gal") to about 24 lb/gal. In certain examples, the packer fluids may have a density in the range of from about 14 lb/gal to about 22 lb/gal. In specific examples, the packer fluids may have a density between any of and/or including any of about 10 lb/gal, about 11 lb/gal, about 12 lb/gal, about 13 lb/gal, about 14 lb/gal, about 15 lb/gal, about 16 lb/gal, about 17 lb/gal, about 18 lb/gal, about 19 lb/gal, about 20 lb/gal, about 21 lb/gal, about 22 lb/gal, about 23 lb/gal, or about 24 lb/gal. In some optional examples, weighting additives (e.g., weighting agents) may be used to increase the density of the packer fluids. Examples of suitable weighting additives may include barite, hematite, hausmannite, calcium carbonate, siderite, ilmenite, or combinations thereof. In particular embodiments, the weighting additives may have a specific gravity of 2 or greater. Those of ordinary skill in the art, with the benefit of this disclosure, should recognize the appropriate density required for a particular application.

25 [0023] Those of ordinary skill in the art should appreciate that examples of the packer fluids generally should have a thermal conductivity suitable for a particular application. By way of example, the packer fluids may have a thermal conductivity in the range of from about 0.001 BTU/H\*ft\*°F to about 1.0 BTU/H\*ft\*°F. In certain examples, the packer fluids may have a thermal conductivity in the range of from about 0.01 BTU/H\*ft\*°F to about 0.03 BTU/H\*ft\*°F. Those of ordinary skill in the art, with the benefit of this disclosure, should recognize the appropriate thermal conductivity required for a particular application.

35 [0024] In some embodiments, a fluorinated cleaning fluid may be used to clean equipment and/or surfaces that have contacted the packer fluids disclosed herein. Such fluorinated cleaning fluids may be polyfluorinated or perfluorinated and may be used neat.

Generally the fluorinated cleaning fluids would comprise boiling points from about 55°C to about 270 °C, have no flash point, have a low molecular weight, and be non-flammable. A commercial example of a suitable fluorinated cleaning fluid is GALDEN<sup>®</sup> HT 110 which has a boiling point of 110 °C, average molecular weight of 580 a.m. u., low vapor pressure of 17  
5 torr at 25°C, dielectric constant of 1.9, and is available from Solvay Plastics in Alpharetta, Georgia. The fluorinated cleaning fluids may be miscible with the fluoruous oils used in the packer fluids described herein. Typically, after the equipment or tools have been used with the packer fluids described herein, the equipment and tools may be considered fluoruous-wet and the surface may be coated with the fluoruous oil used in the packer fluid. The fluoruous oil  
10 may be readily removed by rinsing or immersing the equipment or tool in the fluorinated cleaning fluid, which will clean the surface of any fluoruous materials and return the surface back to its original state. After the equipment or tool is no longer in the presence of the fluorinated cleaning fluid, any residual fluorinated cleaning will rapidly evaporate. The resulting surface is then clean, and additional routine cleaning methods can be carried out as  
15 needed.

[0025] A method of treating a well is provided. The method may comprise providing a packer fluid comprising a fluoruous oil; and introducing the packer fluid into a wellbore. Introducing the packer fluid into the wellbore may further comprise introducing the packer fluid into a volume above a packer and inside a casing. The fluoruous oil may comprise a  
20 perfluoropolyether. The packer fluid may consist of the fluoruous oil. The packer fluid may be in the form of an invert emulsion, and wherein the fluoruous oil is the external phase of the invert emulsion. The internal phase may comprise a salt-free, non-chloride containing aqueous fluid. The internal phase may comprise a polyol. The internal phase may comprise a mixture comprising water and the polyol, wherein the polyol is present in an amount of  
25 about 20% to about 99% by weight of the mixture. The internal phase may comprise a brine. The fluoruous oil may further comprise a fluoruous surfactant. The packer fluid may further comprise at least one additive selected from the group consisting of fluid loss additive, corrosion inhibitor, viscosifier, weighting agent, lost circulation material, and combinations thereof. The packer fluid may have a density of about 14 pounds per gallon to about 22  
30 pounds per gallon. The packer fluid may have a thermal conductivity less than 1.0 BTU/h\*ft\*°F.

[0026] A system for treating a well is provided. The system may comprise a fluid handling system containing a packer fluid, wherein the packer fluid comprises a fluoruous oil; and a fluid conduit coupled to the pumping system and in fluid communication with a  
35 wellbore. The system may further comprise a packer and a casing, wherein the packer and

the casing define a volume in the wellbore capable of containing the packer fluid. The fluid handling system may comprise mixing equipment and a pump. The fluorinated oil may comprise a perfluoropolyether. The packer fluid may consist of the fluorinated oil. The packer fluid may be in the form of an invert emulsion, and wherein the fluorinated oil is the external phase of the invert emulsion. The internal phase may comprise a salt-free, non-chloride containing aqueous fluid. The internal phase may comprise a polyol. The internal phase may comprise a mixture comprising water and the polyol, wherein the polyol is present in an amount of about 20% to about 99% by weight of the mixture. The internal phase may comprise a brine. The fluorinated oil may further comprise a fluorinated surfactant. The packer fluid may further comprise at least one additive selected from the group consisting of fluid loss additive, corrosion inhibitor, viscosifier, weighting agent, lost circulation material, and combinations thereof. The packer fluid may have a density of about 14 pounds per gallon to about 22 pounds per gallon. The packer fluid may have a thermal conductivity less than 1.0 BTU/h\*ft\*\*F.

[0027] The example packer fluids disclosed herein may directly or indirectly affect one or more components or pieces of equipment associated with the preparation, delivery, recapture, recycling, reuse, and/or disposal of the disclosed packer fluids. Any of the packer fluids described herein may be contained within a vessel and/or any type of sufficient storage system. Without limitation, examples of such vessels, may include mud pits, barrels, mixers, drums, trucks, storage containers, etc. Some of the example vessels may comprise mixing equipment, for example, baffles. Any of the vessel examples may be coupled to any of the pumps, pumping systems, conduits, or fluid recovery systems disclosed herein. Any of the pumps, pumping systems, or conduits disclosed herein may be coupled to one another as well as any other upstream or downstream system or equipment, such as vessels, storage systems, fluid recovery systems, and the like. Further, fluid recovery systems comprising vessels and/or pumping systems may be used to recover any of the packer fluids described herein. These recovered packer fluids may be reconditioned and recycled, may be stored (e.g., using a storage system or vessel), or may simply be reused.

[0028] Referring now to FIG. 1, a fluid handling system 10 is illustrated. A packer fluid comprising a fluorinated oil may be provided. In alternative examples, a packer fluid comprising a fluorinated oil external phase and an aqueous or nonaqueous internal phase may be provided. The packer fluid may be mixed in mixing equipment 12, such as a mixer, recirculating tub, or any type of vessel comprising mixing equipment, and then pumped via pump 14 or any type of pumping system to the well bore via fluid conduit 16. Fluid conduit 16 may be any conduit coupled to pump 14 and may also be in fluid communication with

pump 16 and the wellbore. Thus, fluid conduit 16 may convey a fluid, e.g., any of the example packer fluids disclosed herein, from pump 14 to the wellbore, where the fluid may be deposited within any section or location of the wellbore.

[0029] The packer fluids used herein may comprise any of the formulations of the disclosed packer fluids discussed above. For example, the packer fluids may comprise a fluoruous oil. The fluoruous oil may be solids free or may optionally comprise solids, such as weighting additives. Alternatively, the packer fluids may comprise an invert emulsion comprising a fluoruous oil external phase, and an aqueous or nonaqueous internal phase. The disclosed packer fluids may be used to maintain hydrostatic pressure, prevent wellbore collapse, prevent or mitigate heat transfer to or from thermally conductive materials, reduce corrosion, and/or generally control the formation.

[0030] FIG. 2 illustrates a packer fluid that has been introduced, e.g., by a fluid conduit 16 into wellbore 18 and allowed to remain therein. The packer fluid 20 is pumped downhole so that it is disposed within a volume above the packer 22 and inside the casing 24. As illustrated, the packer fluid 20 may be disposed within the casing 22 above a production zone 26 in a subterranean formation 28. Production tubing 30 may be a conduit used for the transfer and production of hydrocarbons from producing zone 26 while packer fluid 20 assists in maintaining hydrostatic pressure. FIG. 2 illustrates the use of a packer fluid 20 just prior to production. However, packer fluid 20 may be used in a similar fashion during drilling of the wellbore if desired. At least a portion of packer fluid 20 may be left behind in the wellbore. In further optional examples, at least a portion of packer fluid 20 may be recovered. The recovered packer fluid may be recovered using a recovery system and optionally a storage system, said systems may comprise some of the equipment discussed above, for example vessels, pumps, conduits, etc.

[0031] The exemplary packer fluids disclosed herein may directly or indirectly affect one or more components or pieces of equipment associated with the preparation, delivery, recapture, recycling, reuse, and/or disposal of the disclosed packer fluids. For example, the disclosed packer fluids may directly or indirectly affect one or more mixers, related mixing equipment, mud pits, storage facilities or units, composition separators, heat exchangers, sensors, gauges, pumps, compressors, and the like used generate, store, monitor, regulate, and/or recondition the exemplary packer fluids. The disclosed packer fluids may also directly or indirectly affect any transport or delivery equipment used to convey the packer fluids to a well site or downhole such as, for example, any transport vessels, conduits, pipelines, trucks, tubulars, and/or pipes used to compositionally move the packer fluids from one location to another, any pumps, compressors, or motors (e.g., topside or downhole) used

to drive the packer fluids into motion, any valves or related joints used to regulate the pressure or flow rate of the packer fluids, and any sensors (i.e., pressure and temperature), gauges, and/or combinations thereof, and the like. The disclosed packer fluids may also directly or indirectly affect the various downhole equipment and tools that may come into contact with the packer fluids such as, but not limited to, wellbore casing, wellbore liner, completion string, insert strings, drill string, coiled tubing, slickline, wireline, drill pipe, drill collars, mud motors, downhole motors and/or pumps, cement pumps, surface-mounted motors and/or pumps, centralizers, turbolizers, scratchers, floats (e.g., shoes, collars, valves, etc.), logging tools and related telemetry equipment, actuators (e.g., electromechanical devices, hydromechanical devices, etc.), sliding sleeves, production sleeves, plugs, screens, filters, flow control devices (e.g., inflow control devices, autonomous inflow control devices, outflow control devices, etc.), couplings (e.g., electro-hydraulic wet connect, dry connect, inductive coupler, etc.), control lines (e.g., electrical, fiber optic, hydraulic, etc.), surveillance lines, drill bits and reamers, sensors or distributed sensors, downhole heat exchangers, valves and corresponding actuation devices, tool seals, packers, cement plugs, bridge plugs, and other wellbore isolation devices, or components, and the like.

### EXAMPLES

[0032] To facilitate a better understanding of the present claims, the following examples of certain aspects of the disclosure are given. In no way should the following examples be read to limit, or define, the entire scope of the claims.

#### Example 1

[0033] The following example is a comparative example provided to illustrate the ability of the disclosed packer fluids to resist heat transfer by comparing the thermal conductivity of the packer fluid formulations disclosed herein against other types of packer fluids. Two sample packer fluids were prepared comprising two different perfluoropolyether fluorinated oils. The two fluorinated oil samples were compared to fresh water, a brine, and an aqueous-based insulating packer fluid. The thermal conductivities of each fluid are illustrated in Table 1 below.

**Table 1**  
**Thermal Conductivities**

Material	Thermal Conductivity (BTU/h*ft**F)
Brine	0.347
Fresh Water	0.288
Aqueous Packer Fluid	0.123-0.177
Perfluoropolyether 1	0.028
Perfluoropolyether 2	0.045

[0034] As illustrated, the two fluoruous oil samples had markedly lower thermal conductivity values than the other fluids. Low thermal conductivity values may be of benefit in operations in which it is desirable to mitigate heat transfer between materials.

**Example 2**

5 [0035] Four packer fluid samples were prepared comprising an invert emulsion of a fluoruous oil and water. The fluoruous oil was FOMBLIN<sup>®</sup>, available from Solvay Plastics in Alpharetta, Georgia. The water was a calcium chloride brine (24 wt.%). The samples further contained FLUOROLINK<sup>®</sup> F10 fluorosurfactant available from Solvay Plastics in Alpharetta, Georgia and enough barite to provide a fluid density of 18 lb/gal. The external  
10 phase to internal phase of each sample was varied according to the amount shown in Table 2 below to differentiate each sample.

[0036] The apparent viscosities of each sample were measured using a Model 35A Fann Viscometer and a No. 2 spring, in accordance with the procedure set forth in API RP Practice 13B-2, *Recommended Practice for Field Testing of Oil-Based Drilling Fluids*. The  
15 data is presented in Table 2 below.

**Table 2**  
**Packer Fluid Rheological Profile**

Ext./Int.	Fann 35 Readings						10s/10m gel, lb/100 ft <sup>2</sup>
	3	6	100	200	300	600	
60/40	44	58	OS	OS	OS	OS	49/80
70/30	28	32	147	252	OS	OS	40/110
80/20	20	23	96	164	231	OS	30/65
90/10	4	5	33	63	93	180	9/10

OS = Off Scale

[0037] As shown by these measurements, the viscosity of all the samples remained  
20 high. The viscosity was the lowest with an external to internal ratio of 90/10 and overall viscosity increased as the proportion of the internal phase increased.

[0038] The preceding description provides various embodiments of the systems and methods of use disclosed herein which may contain different method steps and alternative combinations of components. It should be understood that, although individual embodiments  
25 may be discussed herein, the present disclosure covers all combinations of the disclosed embodiments, including, without limitation, the different component combinations, method step combinations, and properties of the system. It should be understood that the compositions and methods are described in terms of “comprising,” “containing,” or “including” various components or steps, the compositions and methods can also “consist  
30 essentially of” or “consist of” the various components and steps. Moreover, the indefinite

articles "a" or "an," as used in the claims, are defined herein to mean one or more than one of the element that it introduces.

[0039] For the sake of brevity, only certain ranges are explicitly disclosed herein. However, ranges from any lower limit may be combined with any upper limit to recite a range not explicitly recited, as well as, ranges from any lower limit may be combined with any other lower limit to recite a range not explicitly recited, in the same way, ranges from any upper limit may be combined with any other upper limit to recite a range not explicitly recited. Additionally, whenever a numerical range with a lower limit and an upper limit is disclosed, any number and any included range falling within the range are specifically disclosed. In particular, every range of values (of the form, "from about a to about b," or, equivalently, "from approximately a to b," or, equivalently, "from approximately a-b") disclosed herein is to be understood to set forth every number and range encompassed within the broader range of values even if not explicitly recited. Thus, every point or individual value may serve as its own lower or upper limit combined with any other point or individual value or any other lower or upper limit, to recite a range not explicitly recited.

[0040] Therefore, the present embodiments are well adapted to attain the ends and advantages mentioned as well as those that are inherent therein. The particular embodiments disclosed above are illustrative only, and may be modified and practiced in different but equivalent manners apparent to those skilled in the art having the benefit of the teachings herein. Although individual embodiments are discussed, the disclosure covers all combinations of all of the embodiments. Furthermore, no limitations are intended to the details of construction or design herein shown, other than as described in the claims below. Also, the terms in the claims have their plain, ordinary meaning unless otherwise explicitly and clearly defined by the patentee. It is therefore evident that the particular illustrative embodiments disclosed above may be altered or modified and all such variations are considered within the scope and spirit of those embodiments. If there is any conflict in the usages of a word or term in this specification and one or more patent(s) or other documents that may be incorporated herein by reference, the definitions that are consistent with this specification should be adopted.

What is claimed is:

1. A method of treating a well comprising:  
providing a packer fluid comprising a fluoruous oil; and  
introducing the packer fluid into a wellbore.
- 5 2. A method according to claim 1, wherein the introducing the packer fluid into the wellbore comprises introducing the packer fluid into a volume above a packer and inside a casing.
3. A method according to claim 1 or 2, wherein the fluoruous oil comprises a perfluoropolyether.
- 10 4. A method according to any one of claims 1 to 3, wherein the packer fluid consists of the fluoruous oil.
5. A method according to any of claims 1 to 3, wherein the packer fluid is in the form of an invert emulsion, and wherein the fluoruous oil is the external phase of the invert emulsion.
- 15 6. A method according to claim 5, wherein the internal phase comprises a salt-free, non-chloride containing aqueous fluid.
7. A method according to claim 5 or 6, wherein the internal phase comprises a polyol.
8. A method according to any of claims 5 to 7, wherein the internal phase  
20 comprises a mixture comprising water and the polyol, wherein the polyol is present in an amount of about 20% to about 99% by weight of the mixture.
9. A method according to claim 5, wherein the internal phase comprises a brine.
10. A method according to any of claims 1 to 3 or 5 to 9, wherein the fluoruous oil further comprises a fluoruous surfactant.
- 25 11. A method according to any of claims 1 to 3 or 5 to 10, wherein the packer fluid further comprises at least one additive selected from the group consisting of fluid loss additive, corrosion inhibitor, viscosifier, weighting agent, lost circulation material, and combinations thereof.
12. A method according to any of claims 1 to 11, wherein the packer fluid has a  
30 density of about 14 pounds per gallon to about 22 pounds per gallon.
13. A method according to any of claims 1 to 12, wherein the packer fluid has a thermal conductivity less than 1.0 BTU/h\*ft\*°F.
14. A system for treating a well comprising:



a fluid handling system containing a packer fluid, wherein the packer fluid comprises a fluoruous oil; and

a fluid conduit coupled to the pumping system and in fluid communication with a wellbore.

5           15.    A system according to claim 14, further comprising a packer and a casing, wherein the packer and the casing define a volume in the wellbore capable of containing the packer fluid.

          16.    A system according to claim 14 or 15, wherein the fluid handling system comprises mixing equipment and a pump.

10           17.    A system according to any of claims 14 to 16, wherein the fluoruous oil comprises a perfluoropolyether.

          18.    A system according to any of claims 14 to 17, wherein the packer fluid is in the form of an invert emulsion, and wherein the fluoruous oil is the external phase of the invert emulsion.

15           19.    A system according to claim 18, wherein the internal phase comprises a salt-free, non-chloride containing aqueous fluid.

          20.    A system according to claim 18 or 19, wherein the internal phase comprises a polyol.

## AMENDED CLAIMS

received by the International Bureau on 14 March 2016 (14.03.2016)

1. (Currently Amended) A method of treating a well comprising:  
providing a packer fluid, wherein (i) the packer fluid consists of a  
fluorous oil or (ii) wherein the packer fluid is in the form of an invert emulsion and wherein  
5 the fluorous oil is the external phase of the invert emulsion; and  
introducing the packer fluid into a wellbore.
2. (Original) A method according to claim 1, wherein the introducing the packer  
fluid into the wellbore comprises introducing the packer fluid into a volume above a packer  
and inside a casing.
- 10 3. (Original) A method according to claim 1 or 2, wherein the fluorous oil  
comprises a perfluoropolyether.
4. (Canceled)
5. (Canceled)
6. (Currently Amended) A method according to claim 1, wherein the internal  
15 phase comprises a salt-free, non-chloride containing aqueous fluid.
7. (Currently Amended) A method according to claim 1 or 6, wherein the internal  
phase comprises a polyol.
8. (Currently Amended) A method according to any of claim 6 or 7, wherein the  
internal phase comprises a mixture comprising water and the polyol, wherein the polyol is  
20 present in an amount of about 20% to about 99% by weight of the mixture.
9. (Currently Amended) A method according to claim 1, wherein the internal  
phase comprises a brine.
10. (Currently Amended) A method according to any of claims 1 to 3 or 6 to 9,  
wherein the fluorous oil further comprises a fluorous surfactant.
- 25 11. (Currently Amended) A method according to any of claims 1 to 3 or 6 to 10,  
wherein the packer fluid further comprises at least one additive selected from the group  
consisting of fluid loss additive, corrosion inhibitor, viscosifier, weighting agent, lost  
circulation material, and combinations thereof.
12. (Currently Amended) A method according to any of claims 1 to 3 or 6 to 11,  
30 wherein the packer fluid has a density of about 14 pounds per gallon to about 22 pounds per  
gallon.
13. (Currently Amended) A method according to any of claims 1 to 3 or 6 to 12,  
wherein the packer fluid has a thermal conductivity less than 1.0 BTU/h\*ft\*\*F.
- 35 14. (Original) A system for treating a well comprising:

a fluid handling system containing a packer fluid, wherein the packer fluid comprises a fluoruous oil; and

a fluid conduit coupled to the pumping system and in fluid communication with a wellbore.

5           15.   (Original)A system according to claim 14, further comprising a packer and a casing, wherein the packer and the casing define a volume in the wellbore capable of containing the packer fluid.

          16.   (Original)A system according to claim 14 or 15, wherein the fluid handling system comprises mixing equipment and a pump.

10           17.   (Original)A system according to any of claims 14 to 16, wherein the fluoruous oil comprises a perfluoropolyether.

          18.   (Original)A system according to any of claims 14 to 17, wherein the packer fluid is in the form of an invert emulsion, and wherein the fluoruous oil is the external phase of the invert emulsion.

15           19.   (Original)A system according to claim 18, wherein the internal phase comprises a salt-free, non-chloride containing aqueous fluid.

          20.   (Original)A system according to claim 18 or 19, wherein the internal phase comprises a polyol

1/2

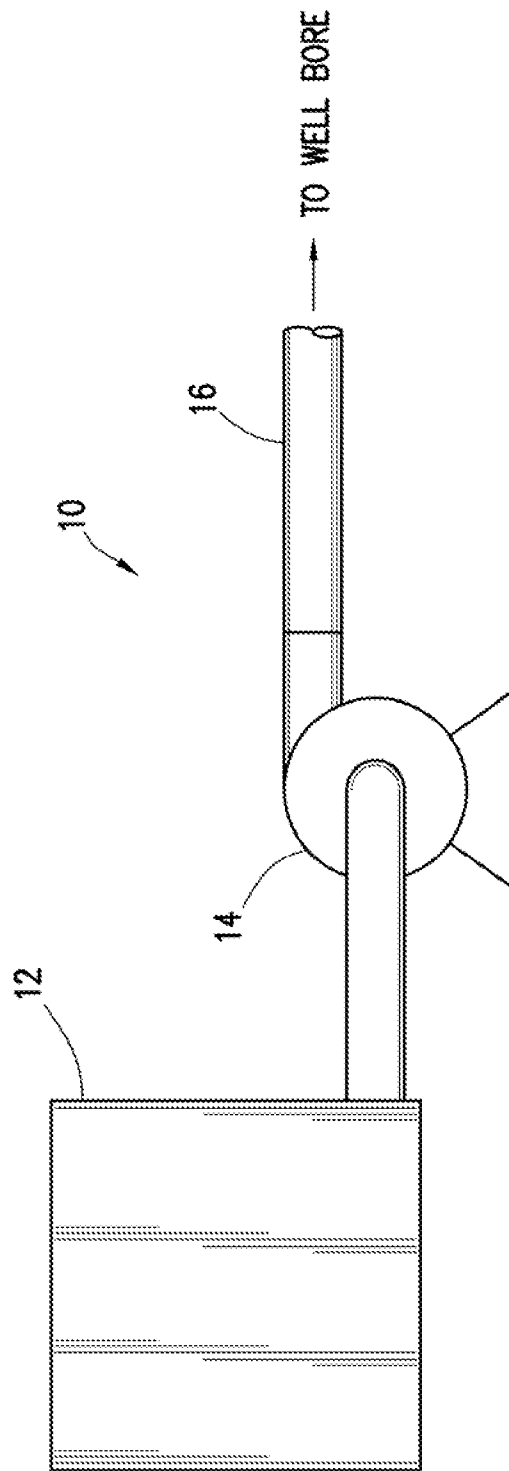

FIG. 1

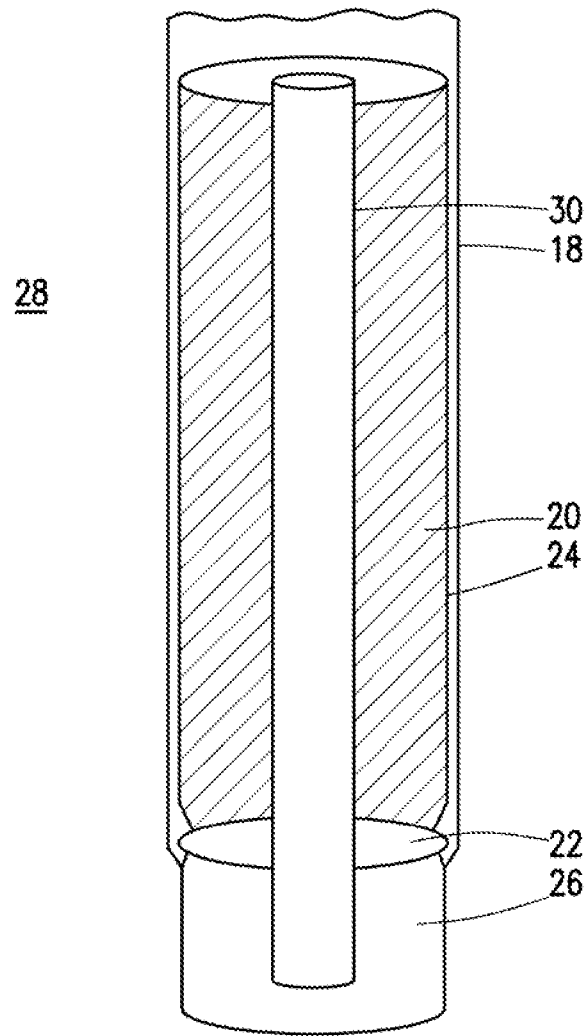

FIG. 2

## INTERNATIONAL SEARCH REPORT

International application No.  
**PCT/US2014/072204****A. CLASSIFICATION OF SUBJECT MATTER****E21B 33/12(2006.01)i, C09K 8/02(2006.01)i**

According to International Patent Classification (IPC) or to both national classification and IPC

**B. FIELDS SEARCHED**

Minimum documentation searched (classification system followed by classification symbols)

E21B 33/12; C09K 8/02; B01J 13/00; C09K 8/035; C09K 8/24; C11D 7/28; E21B 43/16; C09K 8/62; C09K 8/60

Documentation searched other than minimum documentation to the extent that such documents are included in the fields searched

Korean utility models and applications for utility models

Japanese utility models and applications for utility models

Electronic data base consulted during the international search (name of data base and, where practicable, search terms used)

eKOMPASS(KIPO internal) &amp; Keywords: packer fluid, fluoruous oil, packer, casing, annulus, wellbore, invert emulsion, perfluoropolyether, fluid handling system, fluid conduit, pumping system and polyol

**C. DOCUMENTS CONSIDERED TO BE RELEVANT**

Category*	Citation of document, with indication, where appropriate, of the relevant passages	Relevant to claim No.
X	US 2014-0060841 A1 (MORRIS et al.) 06 March 2014 See paragraphs [0001]-[0037].	1-3, 14-16
A	US 2010-0307831 A1 (PASQUIER et al.) 09 December 2010 See paragraphs [0024]-[0062].	1-3, 14-16
A	US 2009-0192051 A1 (CARMAN, PAUL S.) 30 July 2009 See paragraphs [0007]-[0010].	1-3, 14-16
A	US 6235701 B1 (SENGER ELSERND, CHERYL L.) 22 May 2001 See column 1, line 46-column 2, line 31.	1-3, 14-16
A	US 4990283 A (VISCA et al.) 05 February 1991 See column 1, line 7-column 2, line 63.	1-3, 14-16

 Further documents are listed in the continuation of Box C. See patent family annex.

\* Special categories of cited documents:

"A" document defining the general state of the art which is not considered to be of particular relevance

"E" earlier application or patent but published on or after the international filing date

"L" document which may throw doubts on priority claim(s) or which is cited to establish the publication date of another citation or other special reason (as specified)

"O" document referring to an oral disclosure, use, exhibition or other means

"P" document published prior to the international filing date but later than the priority date claimed

"T" later document published after the international filing date or priority date and not in conflict with the application but cited to understand the principle or theory underlying the invention

"X" document of particular relevance; the claimed invention cannot be considered novel or cannot be considered to involve an inventive step when the document is taken alone

"Y" document of particular relevance; the claimed invention cannot be considered to involve an inventive step when the document is combined with one or more other such documents, such combination being obvious to a person skilled in the art

"&amp;" document member of the same patent family

Date of the actual completion of the international search

26 August 2015 (26.08.2015)

Date of mailing of the international search report

**27 August 2015 (27.08.2015)**

Name and mailing address of the ISA/KR



 International Application Division  
 Korean Intellectual Property Office  
 189 Cheongsu-ro, Seo-gu, Daejeon Metropolitan City, 35208,  
 Republic of Korea

Facsimile No. +82-42-472-7140

Authorized officer

PARK, Tae Wook

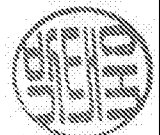
Telephone No. +82-42-481-3405



**Box No. II Observations where certain claims were found unsearchable (Continuation of item 2 of first sheet)**

This international search report has not been established in respect of certain claims under Article 17(2)(a) for the following reasons:

1.  Claims Nos.:  
because they relate to subject matter not required to be searched by this Authority, namely:
  
2.  Claims Nos.: 6, 9, 19  
because they relate to parts of the international application that do not comply with the prescribed requirements to such an extent that no meaningful international search can be carried out, specifically:  
The claims each refer to a multiple dependent claim that refers to other multiple dependent claims. Therefore, the meaning of the technical feature to which it refers is vague and unclear.
  
3.  Claims Nos.: 4-5, 7-8, 10-13, 17-18, 20  
because they are dependent claims and are not drafted in accordance with the second and third sentences of Rule 6.4(a).

**Box No. III Observations where unity of invention is lacking (Continuation of item 3 of first sheet)**

This International Searching Authority found multiple inventions in this international application, as follows:

1.  As all required additional search fees were timely paid by the applicant, this international search report covers all searchable claims.
  
2.  As all searchable claims could be searched without effort justifying an additional fees, this Authority did not invite payment of any additional fees.
  
3.  As only some of the required additional search fees were timely paid by the applicant, this international search report covers only those claims for which fees were paid, specifically claims Nos.:
  
  
  
  
  
  
  
  
  
  
4.  No required additional search fees were timely paid by the applicant. Consequently, this international search report is restricted to the invention first mentioned in the claims; it is covered by claims Nos.:

**Remark on Protest**

- The additional search fees were accompanied by the applicant's protest and, where applicable, the payment of a protest fee.
- The additional search fees were accompanied by the applicant's protest but the applicable protest fee was not paid within the time limit specified in the invitation.
- No protest accompanied the payment of additional search fees.

## INTERNATIONAL SEARCH REPORT

Information on patent family members

International application No.

PCT/US2014/072204

Patent document cited in search report	Publication date	Patent family member(s)	Publication date
US 2014-0060841 A1	06/03/2014	AU 2013-309446 A1	06/03/2014
		AU 2013-309446 B2	11/06/2015
		CA 2881548 A1	06/03/2014
		WO 2014-035500 A1	06/03/2014
US 2010-0307831 A1	09/12/2010	EP 1788061 A1	23/05/2007
		EP 1788061 B1	26/06/2013
		EP 2322586 A1	18/05/2011
		FR 2893626 A1	25/05/2007
		FR 2893626 B1	04/01/2008
		NO 20065293 A	21/05/2007
		US 2007-0123430 A1	31/05/2007
		US 7858564 B2	28/12/2010
		US 8383555 B2	26/02/2013
		US 2009-0192051 A1	30/07/2009
US 2009-0192058 A1	30/07/2009		
US 8022015 B2	20/09/2011		
WO 2009-097286 A1	06/08/2009		
US 6235701 B1	22/05/2001	AU 1999-45466 A1	10/11/2000
		AU 2000-15433 A1	03/07/2000
		BR 9916121 A	04/09/2001
		CA 2255413 A1	11/06/2000
		CA 2356081 A1	22/06/2000
		CA 2356081 C	08/05/2007
		CA 2367946 A1	02/11/2000
		CA 2367946 C	20/05/2008
		EP 1149226 A1	31/10/2001
		EP 1171567 A1	16/01/2002
		JP 2002-532645 A	02/10/2002
		JP 2002-543241 A	17/12/2002
		KR 10-2001-0090882 A	19/10/2001
		MX PA01005880 A	27/03/2002
		NO 20012768 A	02/08/2001
		NO 20012768 D0	06/06/2001
		TR 200101698 T2	21/11/2001
US 6729409 B1	04/05/2004		
WO 00-36272 A1	22/06/2000		
WO 00-65018 A1	02/11/2000		
US 4990283 A	05/02/1991	CN 1019075 B	18/11/1992
		CN 87105163 A	20/04/1988
		EP 0250766 A1	24/03/1999
		EP 0250766 B1	22/09/1999
		JP 2562891 B	19/09/1996
		JP 2562891 B2	11/12/1996
		JP 6323735 A	01/02/1988
		KR 10-0130907 B1	21/04/1998