



INTERNATIONAL APPLICATION PUBLISHED UNDER THE PATENT COOPERATION TREATY (PCT)

(51) International Patent Classification³ : E04H 1/04	A1	(11) International Publication Number: WO 86/ 00106 (43) International Publication Date: 3 January 1986 (03.01.86)
<p>(21) International Application Number: PCT/US84/01115</p> <p>(22) International Filing Date: 18 July 1984 (18.07.84)</p> <p>(31) Priority Application Number: 619,627</p> <p>(32) Priority Date: 11 June 1984 (11.06.84)</p> <p>(33) Priority Country: US</p> <p>(71)(72) Applicant and Inventor: SHUBOW, Calvin [US/US]; 20995 Hunter's Drive, Farmington, MI 48024 (US).</p> <p>(74) Agents: WOOD, Donald, L. et al.; Krass & Young, 2855 Coolidge, Suite 210, Troy, MI 48084 (US).</p> <p>(81) Designated States: AT (European patent), AU, BE (European patent), BR, CH (European patent), DE (European patent), DK, FI, FR (European patent), GB (European patent), JP, LU (European patent), NL (European patent), NO, SE (European patent).</p>		<p>Published <i>With international search report.</i></p>

(54) Title: BUILDING CONSTRUCTION USING HOLLOW CORE WALL**(57) Abstract**

A concrete building formed of precast cored wall slabs (12), floor slabs (14) and precast cored bond beams (36). The precast cored members (12, 14, 36) are manufactured at a remote factory location and transported to the building site where the wall slabs (12) are erected side by side and the bond beams (36) placed along the tops of the wall slabs (12) with a downwardly opening groove in the lower face of the bond beams (36) seating the upper edges of the wall slabs (12) and the cores (44) in the bond beams (36) vertically aligned with the cores (16) in the wall slabs (12). The ends of the floor slabs (14) are then placed on the bond beams (36) in a position spaced from the inner face of an outer flange portion (50) of the bond beams (36) and clear of the aligned cores (16, 44) to form an upwardly opening trough (52). Vertical reinforcing rods (46) are positioned in the vertically aligned cores (16, 44) of the bond beams (38) and wall slabs (12), a horizontal reinforcing rod (54) is placed in the upwardly opening opening trough (52), auxiliary rods (66) are placed in the spaces (68) between the adjacent floor slabs (14) and extend into the trough (52), and cement is poured into the aligned cores (16, 44), the trough (52), and the floor slab spaces (68) to embed the various rods (46, 54, 66) in the poured cement and form a rigid unitary building structure. Insulating panels (18) are secured to at least certain of the wall slabs (12) at the remote factory location so that the wall slabs (12) may be placed side by side with the insulating panels (18) on the exterior of the slabs (12) providing a preformed exterior insulation layer.

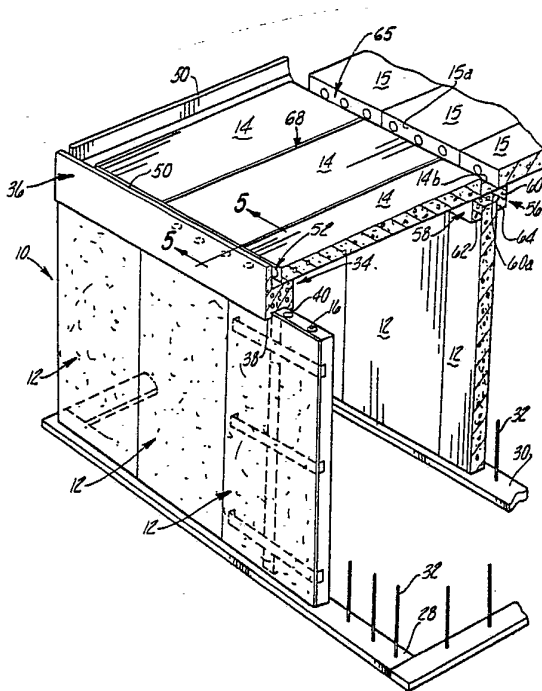

FOR THE PURPOSES OF INFORMATION ONLY

Codes used to identify States party to the PCT on the front pages of pamphlets publishing international applications under the PCT.

AT	Austria	GA	Gabon	MR	Mauritania
AU	Australia	GB	United Kingdom	MW	Malawi
BB	Barbados	HU	Hungary	NL	Netherlands
BE	Belgium	IT	Italy	NO	Norway
BG	Bulgaria	JP	Japan	RO	Romania
BR	Brazil	KP	Democratic People's Republic of Korea	SD	Sudan
CF	Central African Republic	KR	Republic of Korea	SE	Sweden
CG	Congo	LI	Liechtenstein	SN	Senegal
CH	Switzerland	LK	Sri Lanka	SU	Soviet Union
CM	Cameroon	LU	Luxembourg	TD	Chad
DE	Germany, Federal Republic of	MC	Monaco	TG	Togo
DK	Denmark	MG	Madagascar	US	United States of America
FI	Finland	ML	Mali		
FR	France				

-1-

Description
Building Construction Using Hollow Core Wall

Background Of The Invention

5 This invention relates to building constructions and, more particularly, to building constructions utilizing precast concrete slabs with hollow core channels.

This application is a continuation-in-part of U.S. Patent Application S.N. 268,598.

10 Precast concrete slabs with hollow core channels are often used as floors in multistory buildings. The hollow cores are designed to provide passageways for utility cables and the like. The cored slabs are relatively inexpensive and readily available
15 from a variety of sources. The prior art has contemplated using these cored slabs as both the floor panels and upstanding walls for a building. Such a construction is shown in U.S. Patent No. 4,010,581 to Kenturi et al. In that patent the cores are used for
20 routing utility cables through the building. U.S. Patent No. 3,710,527 to Farebrother illustrates the use of the core channels to hold vertical reinforcement rods extending the entire height of the building.

25 Those skilled in the art will appreciate that the joining together of the structure walls and floors is one of the most important procedures in building a rigid, structurally sound multistory building. Unfortunately, it is also one of the most time consuming and expensive steps both in terms of labor and material
30 costs. A reading of the above-mentioned patents illustrates that great care must be taken to insure that these joints are made properly. In the Kenturi et al patent additional vertical openings must be formed in the floor slabs to permit communication between the
35 cores in the vertical wall slabs. Farebrother's floor



-2-

slabs must be provided with specially formed castellated ends which interlock at the joints.

The structural soundness of a multistory building is, of course, of primary concern.

5 Reinforcement rods have been used in the past as one means for increasing the rigidity of the resultant structure. Some prefabricated concrete slabs have reinforcement rods embedded in them during fabrication. These slabs are often designed for specific uses and do

10 not readily lend themselves to multi-purpose applications such as the use of the slabs for walls as well as the floors.

Objects And Summary Of The Invention

It is an object of this invention to provide

15 an extremely rigid multistory building construction using precast concrete slabs with hollow core channels.

It is a further object of this invention to provide such a building construction at relatively low cost both in terms of labor and material costs.

20 The building utilizes precast concrete wall slabs having a plurality of parallel core channels extending vertically therethrough; precast concrete bond beams having at least one core channel extending vertically therethrough; and reinforcing rods.

25 According to the invention building construction, a bond beam is positioned on and extending along the top edge of a wall slab with the core channels in the bond beam aligned with a selected core channel in the wall slab to form a continuous vertical cored passage, and a

30 vertically extending reinforcing rod is positioned in the continuous cord passage and locked to the wall slab and bond beam by poured concrete filling the core channel in the bond beam and filling at least the upper portion of the selected core channel in the wall slab.

35 According to a further feature of the invention building construction, the wall slab forms an outer wall of the building, the bond beam includes a main body portion through which the core channel extends



-3-

and a flange portion extending upwardly from the main body portion adjacent the outer edge thereof; the reinforcing rod extends upwardly above the upper face of the main body portion; and at least one precast concrete floor slab rests on its outer end on the upper face of the main body portion of the bond beam with its outer vertical face spaced from the inner vertical face of the flange portion of the bond beam to form a trough into which the upward extension of the reinforcing rod extends and into which concrete is poured to embed the upward rod extension.

According to a further feature of the invention, the building construction further includes another reinforcing rod extending horizontally in the trough and embedded in the concrete filling the trough.

According to yet another feature of the invention, the vertically extending reinforcing rod extends upwardly above the face of the floor slab and another vertically cored, precast wall slab is positioned with its lower edge resting on the upper face of the floor slab with the upward extension of the vertical reinforcing rod extending upwardly into a vertical core channel in the upper wall slab and locked in position within that core channel by poured concrete filling at least the lower portion of the core channel.

According to another feature of the invention, the precast concrete wall slabs are formed at a manufacturing location remote from the building site; a heat insulative panel is secured at the manufacturing site to a vertical face of each wall slab; the slabs with the secured insulative panels are transported to the building site; and the slabs are erected side by side at the building site to form the walls of the building with the heat insulative panels positioned at the outer surface of the slab to form a heat insulative barrier extending around the exterior of the building.



Brief Description Of The Drawings

FIGURE 1 is a fragmentary perspective view of a building construction according to the present invention;

5 FIGURE 2 is a fragmentary perspective view of a bond beam employed in the invention building construction;

 FIGURE 3 is a perspective view of a precast concrete wall slab having an insulative panel secured to its exterior face;

10 FIGURE 4 is a fragmentary top view of the slab and insulative panel of FIGURE 3;

 FIGURE 5 is a cross-sectional view taken on line 5-5 of FIGURE 1;

15 FIGURE 6 is a cross-sectional view similar to FIGURE 5 but showing, additionally, an upper story wall slab;

 FIGURE 7 is a top view of a building constructed according to the invention;

20 FIGURE 8 is a fragmentary perspective view showing details of the invention bond beam construction;

 FIGURE 9 is a cross-sectional view taken on line 9-9 of FIGURE 7; and

25 FIGURE 10 is a cross-sectional view similar to FIGURE 5 but showing an alternate bond beam joint construction.

Description Of The Preferred Embodiment

30 FIGURE 1 shows a building formed of a plurality of vertical wall slabs 12 and horizontal floor slabs 14 and 15. Floor slabs 14 and 15 may constitute the ceiling of a lower floor in a multi-story building or may constitute a roof structure. Slabs 12, 14 and 15 are formed of precast concrete at a factory manufacturing location remote from the building site.

35 Slabs 12, 14 and 15 include a plurality of parallel core channels 16 which extend from one edge of the slab to an



-5-

opposite edge of the slab between the side faces of the slab.

As best seen in FIGURES 1, 3 and 4, an insulation panels 18, of Styrofoam or other heat insulative material, is secured at the factory to one vertical face of the wall slabs 12 intended for use in forming the outside walls of the building. Each panel 18 is adhesively secured to the vertical face of the wall slab and is also held to that face by a plurality of mesh attachment straps. Specifically, a plurality of mesh straps 20 extend in parallel spaced relation across the outer face of panel 18 and at least one mesh strap 22 extends vertically along the outer face of panel 18. Ends 20A of straps 20 are adhesively secured to the vertical edge faces of slab 12 and the ends 22A of strap 22 are adhesively secured to the top and bottom edge faces of slab 12. A binder layer 24 is sprayed over panel 18 to cover straps 20, 22 and a finish coat 26 of suitable aggregate material is sprayed over binder layer 24 to form the exterior finish for the slab.

Wall slabs 12 are placed side by side on suitable outer and inner foundation structures 28, 30 with spaced upstanding reinforcement rods 32 embedded in foundation structures 28, 30 passing upwardly into core channel 16 to assist in aligning the wall slabs on the foundation structures. The wall slabs 12 positioned on the outer foundation structure 28 include secured insulation panels 18 and are arranged with the insulation panels on the exterior surface of the building. Plain wall slabs 14 are positioned on inner foundation structure 30.

Exterior wall slabs 12 are connected to floor slabs 14 by a joint seen generally at 34. Joint 34 employs a horizontally extending precast bond beam 36 formed at the remote factory location. Bond beam 36, as best seen in FIGURES 5 and 6, includes two spaced downwardly extending flange portions 38 and 40 which form a downwardly opening groove to seat the upper edges of wall slabs 12 and attached insulation panels 18.



-6-

Bond beam 36 may be made of a variety of lengths but, preferably, is of sufficient length to bridge two adjacent wall slabs. Bond beam 36 further includes a main body portion 42 having one or more core channels 44 extending vertically therethrough and one or more reinforcement rods 45 embedded horizontally therein. Bond beam 36 is positioned on the upper edges of wall slabs 12 with core channels 44 aligned with core channels 16 in wall slabs 12. Vertically extending reinforcement rods 46 are positioned in aligned core channels 44, 16 and embedded in poured concrete columns 48 filling core channels 16 and 44.

Bond beam 36 further includes a flange portion 50 extending upwardly from main body portion 42 adjacent the outer edge of the main body portion.

Floor slabs 14 rest on their outer ends on the inner portion of the upper surface 42a of main body portion 42 of beam 36. The outer vertical faces 14a of the floor slabs are spaced from the inner vertical face 50a of beam upper flange portion 50 so as to not substantially obstruct core channels 44 and so as to form an upwardly opening trough 52 defined by surfaces 50a, 42a and 14a. One or more horizontally extending reinforcement rods 54 are positioned in trough 52 and trough 52 is filled with poured concrete to embed rod 54 and rods 46.

In the case of a multi-story building, the upwardly extending projections 46A of vertical reinforcement rods 46 pass upwardly into core channels 16 of upper wall slabs 12 with lower edges 12a of the upper wall slabs resting on the upper surface of the outer ends of floor slabs 14 and the aggregate surface 26 of the upper wall slabs abutting inner surface 50a of bond beam upper face portion 50.

Interior wall slabs 12 positioned on interior foundation structures 30 are interconnected to floor slabs 14, 15 by a joint seen generally at 56. Joint 56 employs an interior bond beam 58 including a main body portion 60, core channels 61, and spaced downwardly



-7-

extending flange portions 62, 64 which form a downwardly opening groove to seat the upper edges of interior wall slabs 14. The inner ends of slabs 14 and 15 rest on the top surface 60a of main body portion 60 with the inner edge surface 14b of slabs 14 spaced from the inner edge surfaces 15a of slabs 15 to form a trough 65 defined by surfaces 14b, 60a, and 15a.

The building 10 of the present invention may be readily constructed as follows. Wall slabs 12, floor slabs 14 and 15, and beams 36 are precast at a remote manufacturing site; panels 18 are secured to selected wall slabs 12; and the slabs and beams are transported to the building site. The wall slabs 12 with attached panels 18 are then placed side by side on foundation structure 28, using rods 28 for alignment purposes, with panels 18 facing outwardly. As the slabs are lowered onto the foundation, lower ends 22 of straps 22 are trapped between the lower end of the slab and the foundation and, as adjacent slabs are moved into abutting relationship, ends 20a of straps 20 are trapped between the juxtaposed vertical edge faces of the slabs to preclude dislodgment of panels 18 from the slabs 12. Beams 36 are now lowered into place over the top edges of slabs 12 with beam flanges 38 and 40 seating the upper ends of the slabs and the attached insulating panels; with the core channels 46 in the beam aligned with the core channels 16 in the slab; and with upper strap ends 22a trapped between the beam and the upper edge surfaces of the slabs. Beams 36 are sized and arranged to insure that one beam spans each juncture between adjacent wall slabs so that the beam flanges assist in the alignment of the adjacent wall slabs. Weld plates 65 (FIGURE 8) are preferably employed at the joints between adjacent beams 36. Weld plates 65 are metallic and are welded to rod sections or other metallic pieces embedded in the beams in the precasting process at the remote manufacturing location.

Floor slabs are now positioned with their one ends resting on the upper surface 42a of beams 36 in a



-8-

position spaced from beam flange inner surface 50a and clearing channels 44. Vertical reinforcement rods 46 are now positioned in aligned core channel 16 and 44; horizontal rods 54 are positioned in trough 52; and auxiliary rods 66 (FIGURE 7, 8 and 9) are placed in the spaces 68 defined between the chamfered edge faces 14c of adjacent floor slabs. Vertical rods 46 may extend all the way down core channel 16 to the foundation structure for attachment to the foundation structure or to rods 32, or may extend only part way down the core channel. In the case of a multi-story building, rods 46 will include an upper portion 46a extending above the level of floor slabs 14. Auxiliary rods 66 are bent, right angle members including a main body portion 66a positioned in space 68 and a bent or hooked portion 66b. Depending on its location and the number of stories in the building, hook portion 66b may extend horizontally in trough 52, downwardly into a beam core channel 44, or upwardly into a wall slab core channel 16. After all of the reinforcement rods are in place, core channels 16 and 44, trough 52, and spaces 68 are filled with poured concrete to form a cement column in core channels 16 and 44 embedding rods 32 and 46; to fill trough 52 with cement embedding horizontal rods 54 and hook ends 66b of auxiliary rods 66; and to embed auxiliary rod main body portions 66a in spaces 68.

The other ends of floor slabs 14 are supported on a simultaneously erected wall structure which may comprise the interior wall erected on interior foundation 30 as in FIGURE 1 or may, in the case of a relatively narrow building, comprise an exterior wall structure. In the case of the interior wall structure of FIGURE 1, wall slabs 12, without insulation panels 18, are erected side by side on the foundation 30 utilizing rods 32 for alignment; bond beams 58 are placed over the top edges of the aligned wall slabs; the inner ends of floor slabs 14 and 15 are spacedly positioned on the upper surface 60a of the beam; a horizontal reinforcement rod 54 is placed in trough 66;



-9-

vertical rods 46 are positioned in aligned core channel 16 and 61; auxiliary rods 66 are placed in spaces 68 with hook portions 66b extending into trough 52 or into core channels 16 or 61; and cement is poured to fill core channels 16 and 61, trough 52, and spaces 68.

Considering a total building structure as seen in top view in FIGURE 7, horizontal reinforcement rods 54 are preferably bent structures which extend in troughs 52 around at least one corner of the building and are secured to other rods 54 (by welding, clips, or screw fittings) to form a complete circular structure extending around the total perimeter of the building and serving to tie the building together. In the structure of FIGURE 7, the horizontal rod 54 positioned in space 65 between slabs 14 and 15 includes hook portions 54a at either end which are suitably tied into the loop structure formed by the rods 54 positioned in troughs 52 to further unitize and tie together the total building structure. Also, further auxiliary rods 70 are preferably employed along the longitudinal sides of the slabs 14, 15 bordering the perimeter of the building. Rods 70 are multi-bend structures and are positioned in outwardly opening channels 72 formed on the job in slabs 14 and 15 in a cutting or grinding operation. Channels 72 are deep enough and extend inwardly from the edge of the slab far enough to break through into a core channel 16. Each rod 70 includes a main body portion 70a positioned in channel 72, a hooked end portion 70b extending downwardly into the exposed core channel 16, and a hooked end portion 70c extending into trough 52 and suitably tied into the reinforcement rod assembly. Channels 72 are filled with poured concrete to embed auxiliary rods 70 therein.

If a multi-story building is contemplated, vertical rods 46 are sized to extend upwardly to provide extensions 46a for alignment of wall slabs 12 of the next floor and a building procedure similar to the described sequence is followed to form the next and succeeding floors.



-10-

The alternate bond beam joint construction seen in FIGURE 10 includes a bond beam joint 74 employing a bond beam 76. Bond beam 76 has a generally H configuration including a web portion 78 having spaced core channels 80; spaced downwardly extending flanges 82 and 84; an inner upwardly extending flange 86; and an outer upwardly extending flange 88 which is significantly higher than inner flange 86. In use, bond beams 76 are placed on top of wall slabs 12 with the upper edge portions of the wall slabs seating in the groove defined between flanges 82 and 84 and beam core channels 80 aligned with slab core channels 16; vertically extending reinforcement rods 90 are positioned in aligned core channels 80, 16; horizontally extending reinforcement rods 92 are positioned in the upwardly opening trough 94 defined between upper beam flanges 86 and 88; locally mixed concrete is poured into core channels 80 and 16 and into trough 92 to embed vertical rods 90 in poured concrete columns and embed rods 92 in trough 94; floor slabs 14 are positioned with their outer ends resting on the upper edges of beam flanges 86; and locally mixed concrete is poured into the space 96 between the confronting faces of floors slabs 14 and the upper portion 88a of flange 88. Flange 88 thus serves as a face plate totally enclosing floor slabs 14. If a multi-story building is contemplated, and as previously described with respect to the bond joint construction of FIGURES 1-9, vertical rods 90 may extend upwardly into the core channels of further wall slabs forming an upper outer wall of the building. Also if desired, a suitable decorative coating 98 may be applied to the outer faces of slabs 12 and beams 76 to provide an aesthetically pleasing appearance for the building.

The described construction provides a simple building having excellent structural rigidity and excellent heat insulative qualities; and the building is provided at relatively low cost since inexpensive precast members are extensively used and the joints



-11-

between the precast members are formed on the job in a relatively simple operation requiring minimal and relatively unskilled labor.

5 Whereas a preferred embodiment of the invention has been illustrated and described in detail, it will be apparent that various changes may be made in the described embodiment without depending from the scope or spirit of the invention.



-12-

CLAIMS

1. A building construction comprising:

5 (A) at least on precast concrete wall slab (12) positioned vertically and having generally parallel core channels (16) extending vertically therethrough from the lower edge thereof to the upper edge thereof between opposite faces thereof;

10 (B) at least one precast concrete bond beam (36) positioned on and extending generally horizontally along the top edge of said wall slab (12) and having at least one core channel (44) extending vertically therethrough and aligned with a selected core channel (16) in said precast slab to form a continuous vertical core passage;

15 (C) a vertically extending reinforcing rod (46) positioned in said continuous core passage; and

20 (D) poured concrete (48) filling said core channel (44) in said precast bond beam (36) to lock said reinforcing rod (46) to said bond beam (36) and filling at least the upper portion of said selected core channel (16) in said precast slab (12) to lock said reinforcing rod (46) to said precast slab (12).

2. A building construction according to Claim 1 wherein:

25 (E) said precast wall slab (12) forms an outer wall of said building construction;

(F) said bond beam includes
30 (1) a main body portion (42) through which said core channel (44) extends; and
(2) a flange portion (50) extending upwardly from said main body portion (42) adjacent the outer edge thereof;

35 (G) said reinforcing rod (46) extends upwardly above the upper face (42a) of said main body portion (42); and



-13-

(H) said building construction further includes

- 5 (1) at least one precast horizontally inwardly extending concrete floor slab (14) resting at its outer end on the upper face of said main body portion (42) of said bond beam (36) and having its outer vertical edge face (14a) spaced from the inner vertical face (50a) of said flange portion (50) to form, in cooperation with the upper face (42a) of said main body portion (42), an upwardly opening trough (52) into which the upward extension (46a) of said reinforcing rod (46) extends, and
- 10
- 15 (2) poured concrete filling said trough (52) and embedding the upward extension (46a) of said reinforcing rod (46).

3. A building construction accordingly to Claim 2 wherein said building construction further includes

20

(I) another reinforcing rod (54) extending horizontally in said trough (52) and embedded in the poured concrete filling said trough (52).

4. A building construction accordingly to Claim 3 wherein

25

(J) said vertically extending reinforcing rod (46) extends upwardly above the upper face of said slab (14); and

(K) said building construction further includes

30

(1) another vertically cored, precast concrete wall slab (12) positioned with its lower edge (12a) resting on the upper face of said floor slab (14) adjacent the outer edge of said floor slab (14) with the upward extension (46a) of said vertically extending rod (46) extending upwardly into a

35



-14-

vertical core channel (16) of said other slab (12), and

5 (2) poured concrete filling at least the lower portion of said vertical core of said other wall slab (12) to embed the upward extension (46a) of said vertically extending rod (46) in said other slab (12).

5. A building construction according to Claim 4 wherein

10 (L) there are a plurality of floor slabs (14) arranged side by side with lateral spaces (68) therebetween;

15 (M) further reinforcing rods (66) are respectively positioned in the lateral spaces (68) between the floor slabs (14) and extend outwardly into said trough (52) where they bend at right angles to form a hook portion (666) embedded in the poured concrete in the trough (52); and

20 (N) poured concrete fills the lateral spaces (68) between the floor slabs (14) to embed said further reinforcing rods (66).

6. A building construction according to Claim 5 wherein certain of said hook portions (66b) extend embeddedly downwardly into a vertical core (44) in said bond beam (36).
25

7. A building construction according to Claim 5 wherein certain of said hook portions (66b) extend embeddedly upwardly into a vertical core (16) in said other slab (12).

30 8. A building construction according to Claim 5 wherein certain of said hook portions (66b) extend horizontally along said trough (52).

9. A building construction according to claim 2 wherein



-15-

(H) said bond beam (36) further includes a downwardly extending flange portion (38,40) against which said wall slab (12) may be abutted.

5 10. A building construction according to Claim 2 wherein

 (H) said bond beam (36) includes a pair of downwardly extending flange portions (38,40) forming, in coaction with the under surface of said main body portion (42), a downwardly opening groove into which the
10 upper end of said wall slab (12) may be fitted.

 11. A building construction comprising;

 (A) a plurality of precast concrete wall slabs (12) positioned side by side to form an outer wall of the building construction;

15 (B) a plurality of panels (18) of heat insulative material conforming in size and shape to said slabs; and

 (C) strap means (20) extending horizontally across the outer face of each of said slabs (12) to
20 secure each of said panels (18) to the outer face of a respective slab (12) and including end portions (20a) securely interposed in the joints between adjacent slabs (12).

 12. A building construction accordingly to
25 Claim 11 wherein

 (D) said building construction further includes

 (1) bond beams (36) positioned on and extending along the top edges of said wall
30 slabs (12) and,

 (2) further strap means (22) extending vertically along the outer face of each of said panels (12) and including lower end portions (22a) clampingly positioned beneath
35 the bottom edge of the respective slab (12) and upper end portions (22a) interposed



-16-

between the top edge of the respective slab (12) and the overlying bond beam (36).

13. A building construction accordingly to Claim 12 wherein

5 (E) said building construction further includes an aggregate exterior finish coat (26) covering the outer face of each insulative panel (18) and said strap means (20,22).

10 14. A method of constructing a building employing precast concrete slabs (12) comprising the steps of (A) forming a plurality of precast concrete slabs (12) at a manufacturing location remote from the building site;

15 (B) thereafter, at said manufacturing location, securing a panel (18) of heat insulative material to a vertical face of each of said slabs (12);

20 (C) thereafter transporting said slabs (12) with said secured insulative panels (18) to the building site; and

25 (D) erecting said slabs (12) side by side at said site to form the outer walls of said building with said insulative panels (18) positioned at the outer surface of said slabs (12) to form a heat insulative barrier around the exterior of said building.

30 15. A method accordingly to Claim 14 wherein (E) following said securement step, an aggregate (26) is applied over the outer surface of said insulative panels (18) to form an exterior coat for said building.

16. A method according to claim 15 wherein said aggregate (26) is sprayed over the outer surface of said insulative panels (18).



-17-

17. A method according to Claim 14 wherein
(E) said securing step comprises passing
straps (20) across each panel (18) and securing the ends
(20a) of the straps (20) to the vertical edge faces of
the respective slab (12) so that as said slabs (12) are
erected side by side at the building site the ends (20a)
of the straps (20) are securedly interposed in the
vertical joints between the adjacent slabs (12).

18. A building construction according to
Claim 10 wherein:

E. said bond beam (76) further includes a
pair of spaced upwardly extending flange portions
(86,88) defining an upwardly opening trough (94) into
which concrete is poured to embed the upper end of said
vertically extending reinforcing rod (90).

19. A building construction according to
Claim 18 wherein:

F. one of said upwardly extending flange
portions (88) is higher than the other upwardly
extending flange portion (86) so that, when the bond
beam is used on an exterior wall of the building, said
one upwardly extending flange portion (88) forms a
faceplate for the building.



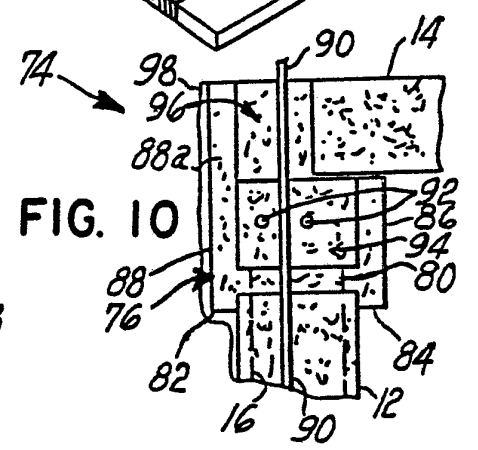
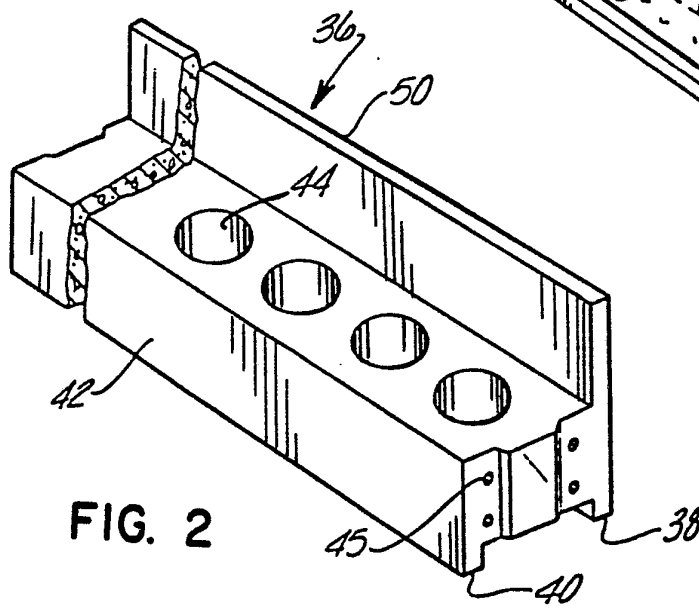
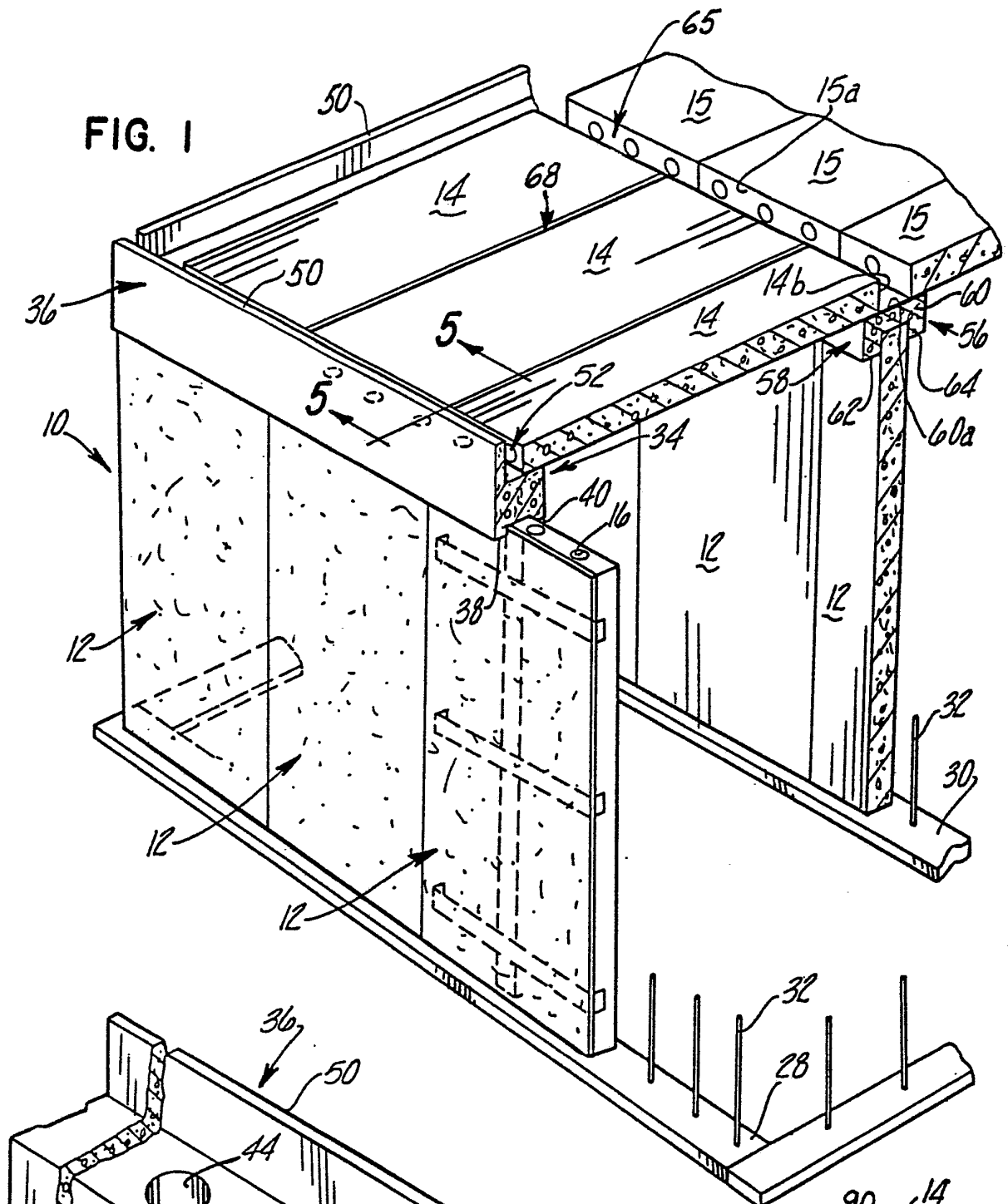

FIG. 2

FIG. 10

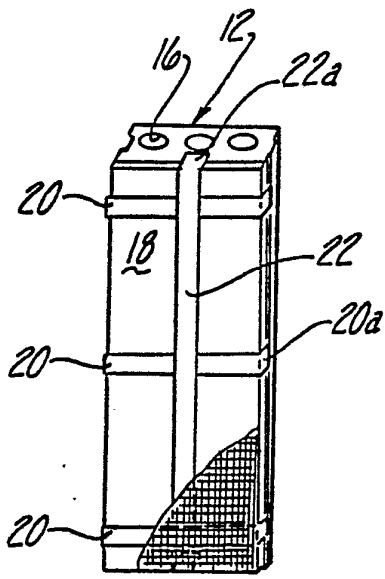

FIG. 3

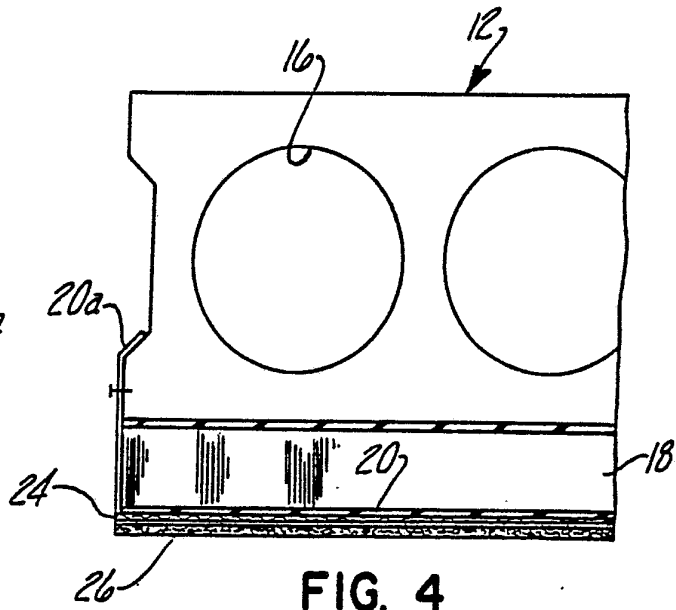

FIG. 4

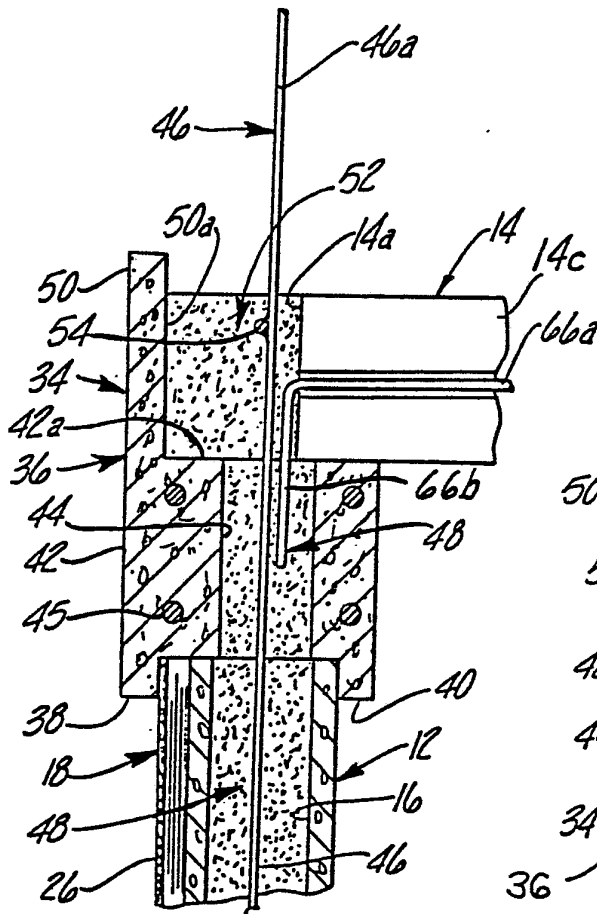

FIG. 5

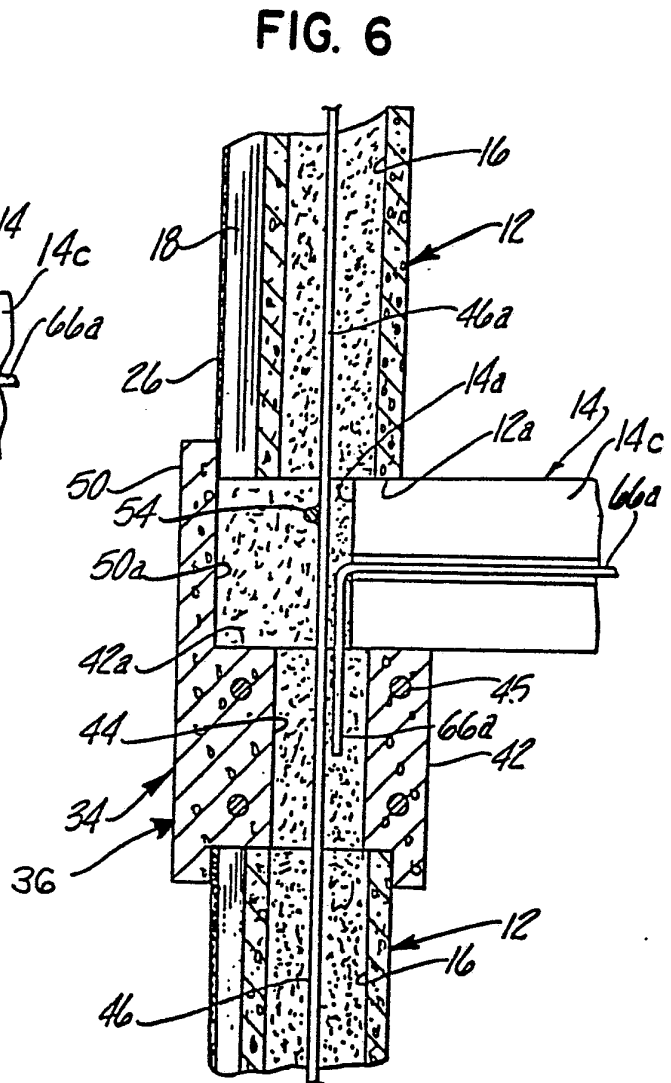

FIG. 6



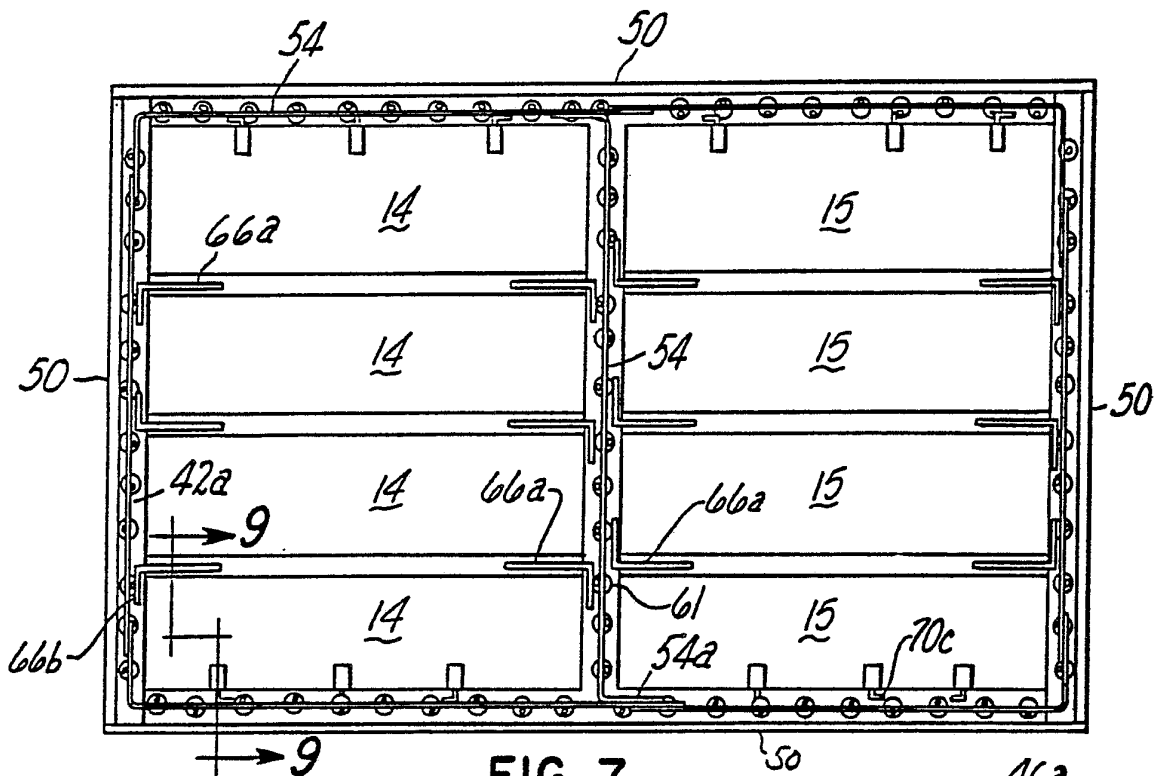

FIG. 7

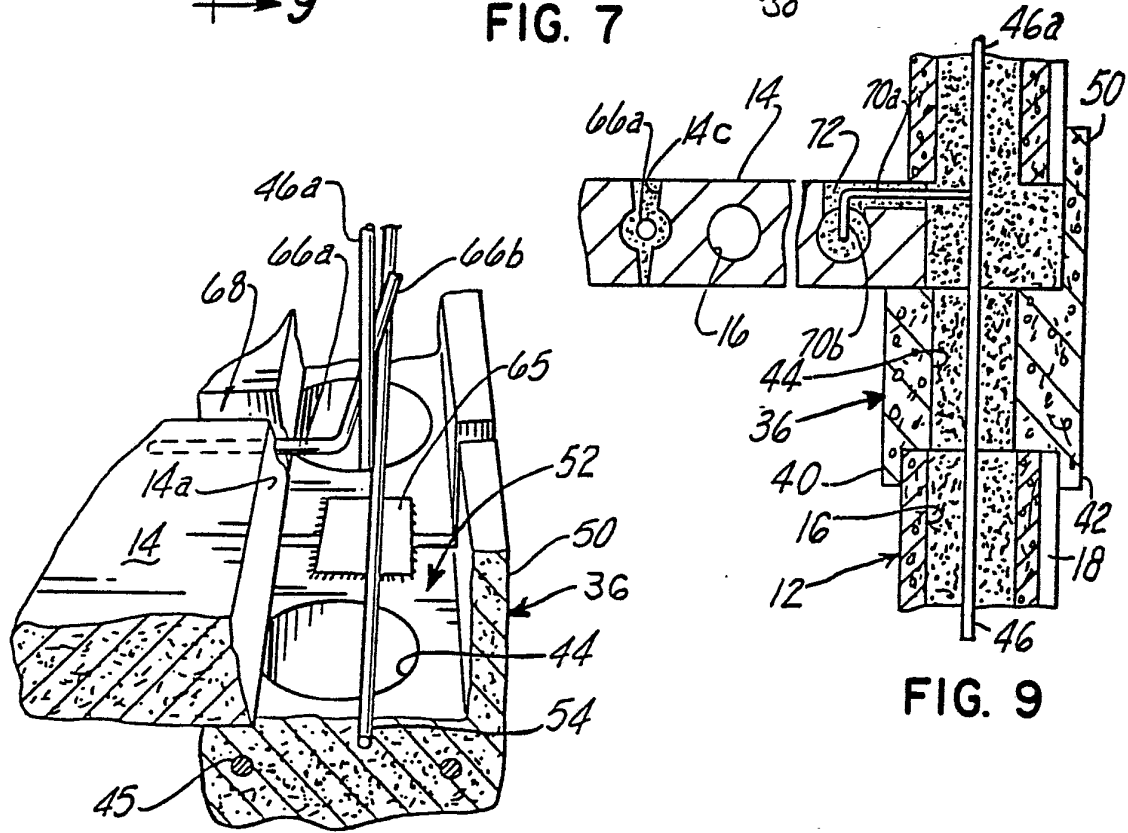

FIG. 8

FIG. 9



INTERNATIONAL SEARCH REPORT

International Application No PCT/US 84/01115

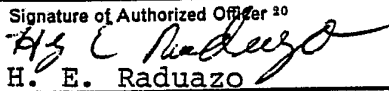
I. CLASSIFICATION OF SUBJECT MATTER (if several classification symbols apply, indicate all) ³		
According to International Patent Classification (IPC) or to both National Classification and IPC ³		
52/236.8 EO4H 1/04		
II. FIELDS SEARCHED		
Minimum Documentation Searched ⁴		
Classification System	Classification Symbols	
U.S.	52/309.4, 309.11, 236.6, 741, 251, 598, 309.8, 309.12, 236.7, 745, 264, 408, 309.9, 309.17, 236.7 747, 597	
Documentation Searched other than Minimum Documentation to the Extent that such Documents are Included in the Fields Searched ⁵		
III. DOCUMENTS CONSIDERED TO BE RELEVANT ¹⁴		
Category [*]	Citation of Document, ¹⁶ with indication, where appropriate, of the relevant passages ¹⁷	Relevant to Claim No. ¹⁸
L	US, A, 4,461,130, published 24 July 1984 Calvin Shubow	1-10
Y	US, A, 4,398,378, published 16 August 1983 Heitzman	1-10
Y	US, A, 3,950,902, published 20 April 1976 Stout	1-10
Y	US, A, 4,018,021, published 19 April 1977 Dow	1-10
Y	US, A, 3,533,204, published 13 October 1970 Wallace	1-10
Y	US, A, 4,010,581, published 08 March 1977 Ketari	1-10
Y	US, A, 3,492,196, published 27 January 1970 Moore	14-17
Y	US, A, 3,638,381, published 01 February 1972 Robertson	14-17
Y	US, A, 4,185,437, published 29 February 1980 Robonson	14-16
Y	US, A, 4,015,387, published 05 April 1977 Tillie	14-16
Y	DE, A, 2,134,533, published 08 February 1973 Eggersmann	14-16
A	US, A, 1,251,830, published 01 January 1918 Siegfried	11-13
<p>[*] Special categories of cited documents: ¹⁵</p> <p>"A" document defining the general state of the art which is not considered to be of particular relevance</p> <p>"E" earlier document but published on or after the international filing date</p> <p>"L" document which may throw doubts on priority claim(s) or which is cited to establish the publication date of another citation or other special reason (as specified)</p> <p>"O" document referring to an oral disclosure, use, exhibition or other means</p> <p>"P" document published prior to the international filing date but later than the priority date claimed</p> <p>"T" later document published after the international filing date or priority date and not in conflict with the application but cited to understand the principle or theory underlying the invention</p> <p>"X" document of particular relevance; the claimed invention cannot be considered novel or cannot be considered to involve an inventive step</p> <p>"Y" document of particular relevance; the claimed invention cannot be considered to involve an inventive step when the document is combined with one or more other such documents, such combination being obvious to a person skilled in the art.</p> <p>"&" document member of the same patent family</p>		
IV. CERTIFICATION		
Date of the Actual Completion of the International Search ²	Date of Mailing of this International Search Report ²	
30 AUG 1984	30 AUG 1984	
International Searching Authority ¹	Signature of Authorized Officer ²⁰	
ISA/US.	 H. E. Raduazo	

FURTHER INFORMATION CONTINUED FROM THE SECOND SHEET

A	US, A, 4,438,611, published 27 March 1984 Bryant	11-13
A, ^p	US, A, 4,455,794, published 26 June 1984 Markinnan	11-13

V. OBSERVATIONS WHERE CERTAIN CLAIMS WERE FOUND UNSEARCHABLE ¹⁰

This international search report has not been established in respect of certain claims under Article 17(2) (a) for the following reasons:

1. Claim numbers because they relate to subject matter ¹² not required to be searched by this Authority, namely:

2. Claim numbers because they relate to parts of the international application that do not comply with the prescribed requirements to such an extent that no meaningful international search can be carried out ¹³, specifically:

VI. OBSERVATIONS WHERE UNITY OF INVENTION IS LACKING ¹¹

This International Searching Authority found multiple inventions in this International application as follows:

1. As all required additional search fees were timely paid by the applicant, this international search report covers all searchable claims of the international application.

2. As only some of the required additional search fees were timely paid by the applicant, this international search report covers only those claims of the international application for which fees were paid, specifically claims:

3. No required additional search fees were timely paid by the applicant. Consequently, this international search report is restricted to the invention first mentioned in the claims; it is covered by claim numbers:

4. As all searchable claims could be searched without effort justifying an additional fee, the International Searching Authority did not invite payment of any additional fee.

Remark on Protest

The additional search fees were accompanied by applicant's protest.

No protest accompanied the payment of additional search fees.