



Europäisches Patentamt  
European Patent Office  
Office européen des brevets



(11) **EP 1 105 614 B1**

(12) **EUROPEAN PATENT SPECIFICATION**

(45) Date of publication and mention  
of the grant of the patent:

**26.03.2003 Bulletin 2003/13**

(21) Application number: **99932694.5**

(22) Date of filing: **19.07.1999**

(51) Int Cl.7: **E06B 9/42, E06B 9/56**

(86) International application number:  
**PCT/DK99/00414**

(87) International publication number:  
**WO 00/005478 (03.02.2000 Gazette 2000/05)**

(54) **A SCREENING ARRANGEMENT FOR A WINDOW AND A UNIVERSAL MOUNTING AND  
PARALLEL GUIDING ARRANGEMENT FOR A WINDOW SCREENING DEVICE**

FENSTER-ABSCHIRMVORRICHTUNG UND EINE UNIVERSELLE BEFESTIGUNGS- UND  
PARALLELFÜHRUNGSVORRICHTUNG FÜR EINE FENSTER-ABSCHIRMVORRICHTUNG

STORE DE FENETRE, MONTAGE UNIVERSEL ET MECANISME DE GUIDAGE PARALLELE POUR  
STORE DE FENETRE

(84) Designated Contracting States:  
**AT BE CH CY DE DK ES FI FR GB GR IE IT LI LU  
MC NL PT SE**  
Designated Extension States:  
**AL LT LV MK RO SI**

(30) Priority: **21.07.1998 DK 96498**

(43) Date of publication of application:  
**13.06.2001 Bulletin 2001/24**

(73) Proprietor: **VKR Holding A/S  
2860 Soeborg (DK)**

(72) Inventor: **LASSEN, Gert, Godvig  
DK-6900 Skjern (DK)**

(74) Representative:  
**Raffnsoee, Knud Rosenstand et al  
Internationalt Patent-Bureau  
Hoeje Taastrup Boulevard 23  
2630 Taastrup (DK)**

(56) References cited:  
**WO-A1-93/18270 WO-A1-96/22447  
WO-A1-98/32944 FR-A1- 2 615 240  
US-A- 5 515 898**

**EP 1 105 614 B1**

Note: Within nine months from the publication of the mention of the grant of the European patent, any person may give notice to the European Patent Office of opposition to the European patent granted. Notice of opposition shall be filed in a written reasoned statement. It shall not be deemed to have been filed until the opposition fee has been paid. (Art. 99(1) European Patent Convention).

## Description

**[0001]** The present invention relates to a screening arrangement for a window, in particular a roof window, comprising a member of screening material, which in an inactive position is rolled up, folded or pleated and takes up a position in or at a horizontal frame or sash member of the window, said member of screening material being at a free end connected with an end profile extending in the width direction of the window, and a parallel guiding arrangement comprising two parallel guiding cords which are separately passed through said end profile and comprise end members protruding from each end thereof, the free ends of the end members of each cord being connected with two opposite frame or sash side members at an upper end of one of said side members and a lower end of the other side member, respectively, and movement of the screening member between said inactive position and an active position being effected by means of an electric driving device.

**[0002]** It is well known, for instance from WO 93/18270, to provide screening devices in the form of blackout shades, roller blinds, folding curtains or Venetian blinds for roof windows with a parallel guiding arrangement, which in a roller or folding blind are passed separately from the bottom end of one sash side member through the bottom bar of the blind to the upper end of the opposite sash side member, the cords crossing each other during the passage through the bottom bar, which is hollow throughout its length.

**[0003]** Likewise, it is well known, for instance from WO 96/22446, to provide a window screening device in the form of for instance a roller blind or a folding blind or a Venetian blind with an electric driving device in connection with cord drums for winding and unwinding of draw cords which are connected with the end bar of the screening device.

**[0004]** The object of the present invention is to provide a new and simplified design of an electrically driven screening device of the type in question, which unlike known embodiments of such devices does not require the building in of the electric driving device in frame or sash members or in a top box or the like mounting unit for the screening device itself.

**[0005]** To meet this object a screening arrangement of the type stated is according to the invention characterized in that the electric driving device comprises at least one drive motor and is positioned in connection with said end profile to act on the two parallel guiding cords via transmission means.

**[0006]** By this design the electric driving device is made integral with the parallel guiding arrangement and may in its entirety be built into the end profile.

**[0007]** The invention may be used in connection with the conventional forms of screening devices, e.g. roller blinds, including roller blinds for blackout shading, folding blinds and Venetian blinds, and irrespective of whether the screening member in the inactive position

takes up a position at the top member or the bottom member of the frame or sash.

**[0008]** Even though the electric driving device may in itself comprise a separate drive motor for each of the two parallel guiding cords, it is preferred to pass the two parallel guiding cords in the end profile around two respective reel members fastened on a common shaft, or a common reel member fastened to a shaft, which through a transmission is connected with a common drive motor.

**[0009]** In order to avoid having to advance electric wiring connections to the end profile with resulting complications the electric driving device comprises in a preferred embodiment of the screening arrangement a battery for supply of current to the drive motor.

**[0010]** According to a particularly preferred embodiment the electric driving device may further comprise a receiver for remote command signals for affecting a motor control circuit for the drive motor. The screening arrangement may then be operated by means of a portable remote-controlled unit of the type which is frequently used for operating electric window operators.

**[0011]** As a consequence of the positioning of the electric driving device in connection with the end profile of the screening member, the invention is not limited to use in complete screening arrangements of the type stated.

**[0012]** It is according to the invention further advantageous if, in connection with the electric driving device, means are provided for manual or automatic uncoupling of the electric driving device by disruption of the current supply, such that manual control of the screening arrangement is made possible.

**[0013]** Therefore, the invention also relates to a universal mounting and parallel guiding arrangement for at least one screening device for a window, in particular a roof window, which screening device comprises a member of screening material, which in an inactive position is rolled up, folded or pleated and takes up a position in or at a horizontal frame or sash member of the window, said member of screening material being at a free end connected with an end member extending in the width direction of the window, said guiding arrangement comprising two parallel guiding cords each with end members having free ends fastened to mounting fittings for connection with two opposite frame or sash side members at the upper end of one of said side members and at a lower end of the other side member, respectively.

**[0014]** According to the invention such a mounting and parallel guiding arrangement, which is disclosed per se in the international patent application WO 98/32944 and which is suitable for post-mounting on an existing screening device, is characterized in that it comprises a mounting profile for releasable connection with said end member, said parallel guiding cords being passed separately through said mounting profile, with said end members protruding from respective ends of said mounting profile, and that an electric driving device act-

ing on the two parallel guiding cords is mounted in connection with the mounting profile.

**[0015]** Advantageous embodiments of such a mounting and parallel guiding arrangement appear from the dependent claims 8 to 19.

**[0016]** Such a mounting and parallel guiding arrangement may be designed as a kind of basic module which comparatively easily may be mounted on already installed windows and which may be used together with the common screening devices in form of roller blinds or folding blinds or Venetian blinds. Such screening devices may in this connection comprise top boxes designed with connection fittings which can easily be connected with the mounting fittings of the basic module.

**[0017]** The invention will be described in the following in more detail with reference to the schematic drawing, in which

Fig. 1 is a perspective view of an embodiment of a screening arrangement according to the invention, Figs 2 and 3 show at a larger scale an embodiment of the electric driving device mounted in the end profile of the screening arrangement,

Fig. 4 shows an embodiment of a separate universal mounting and parallel guiding arrangement, Fig. 5 shows the arrangement in Fig. 4 mounted in a roof window,

Figs 6 and 7 are sectional views of the installation in Fig. 5 at a larger scale,

Fig. 8 is a modification of the embodiment in Figs 4 and 5, and

Fig. 9 is an embodiment of the mounting and parallel guiding arrangement for a double screening arrangement.

**[0018]** In Fig. 1 a screening arrangement according to the invention is shown in the form of a folding blind mounted in a window sash, for instance for a roof window, having a top member 1, side members 2 and 3 and a bottom member 4.

**[0019]** The screening arrangement designed as a folding blind comprises a screening member 5 in the form of a pleated cloth, which may be permeable to light or of a blackout shading material. The screening member 5 is at its upper end secured in a top box 6 which is fastened to the sash top member 1 or to the upper ends of the side members 2 and 3. In the opposite free end the screening member 5 is connected with an end member, which in the embodiment shown is a hollow bottom bar 7. The screening member 5 may be moved between an inactive position, in which it takes up a folded position in the top box 6, and a screening position, in which the bottom bar 7 is brought into abutment against the sash bottom member 4.

**[0020]** To ensure parallel guiding of the bottom bar 7 during movement between the inactive position and the screening position, the arrangement shown comprises a parallel guiding arrangement with two parallel guiding

cords 8 and 9, which are separately connected at one end with the sash top member 1 in the vicinity of one of the side members 2 and 3 and at the other end with the sash bottom member 4 in the vicinity of the second sash side member such that each cord is passed through the hollow bottom bar 7, in which the two cords cross each other. The entire parallel guiding arrangement with the cords 8 and 9 thus extends in an H-like configuration.

**[0021]** In a manner known per se, one end of each of the cords 8 and 9 may be connected with the sash member in question by a biased spring 10, 11 to keep the cords in a tight, stretched position.

**[0022]** In particular, if, in connection with the passage of the parallel guiding cords 8 and 9 through the bottom bar 7, use is made of a braking device of the type known from WO 93/18270, the screening arrangement may be mounted inversely with one end retained in a stationary bottom box in connection with the sash bottom member 4 and the other end connected with a movable end profile.

**[0023]** In the embodiment shown, an electric driving device for the screening arrangement as a whole is mounted in the bottom bar 7, the cords 8 and 9 as shown in Fig. 1 being each passed in opposite directions around two reel members 12 and 13 which are secured to a common shaft 14.

**[0024]** The reel shaft 14 is through a suitable transmission, for instance a chain or belt transmission 15 as shown in Figs 2 or 3, connected with a common drive motor 16, which may be designed as a gear motor with a built-in transmission to an output shaft 16a, and current is supplied from a battery package 17 likewise mounted in the bottom bar 7, whereas, in the embodiment shown, an actuation operator in the form of a receiver 18 for eg. IR remote command signals is connected to a control circuit in the motor 16, said signals being emitted by a portable remote control unit of the type which is frequently used in connection with window operators. The components 12-18 in the electric driving device may in the bottom bar 7 be mounted on a common mounting plate 7a.

**[0025]** The drive motor 16 which may be a DC motor with reversible rotational direction may be actuated thereby for movement of the bottom bar 7 and consequently the screening member 5 in both directions between the inactive position and the screening position through direct acting on the parallel guiding cords 8 and 9. With the arrangement shown in Figs 1 - 3, anti-clockwise rotation of the reel members 12 and 13 will thus move the folding blind down towards the screening position, whereas rotation clockwise will move the blind upwards towards the inactive position.

**[0026]** Instead of the arrangement shown with a common drive motor 16 for the cords 8 and 9, separate motors for the two parallel guiding cords may also be used. Furthermore, the two parallel guiding cords in the end profile may be passed around a common reel member fastened to a shaft, which through a transmission is con-

nected with a common drive motor. The end profile may have any appropriate design, eg. one having a U-shaped cross-section.

**[0027]** If, for instance for reasons of space, it is advantageous, the drive motor with accompanying transmission may be mounted on the exterior of the bottom bar 7.

**[0028]** To make it possible to manually operate the arrangement in case of disrupted current supply, for instance in case of blackout of the battery 17, means are provided in connection with the electric driving device for manual or automatic uncoupling in case of power failure. Such means may for instance be the use of a drive motor which is not self-locking or a release coupling between the reel members 12, 13 and the drive motor 16.

**[0029]** In case a drive motor which is not self-locking is used, the reel member or members which is/are normally used in manual operation of the screening arrangement may still be in engagement with the drive motor provided the friction is adapted to the desired operational comfort.

**[0030]** As the integration characteristic for the invention of the electric driving device in the parallel guiding arrangement entails that the electric driving device does not, like in known embodiments of electrically driven screening arrangements, have to be placed in the sash structure, typically either in the top member 1 or the bottom member 4 or in a top box for the screening arrangement, the invention is particularly advantageous in combination with a universal mounting and parallel guiding arrangement, which may be mounted in a window either at the manufacture thereof or after its mounting in the place of use as a preparation for later mounting of a screening device and which may moreover be post-mounted on a mounted screening device.

**[0031]** An embodiment of such a mounting and parallel guiding arrangement is described in the following with reference to Figs 4 - 9.

**[0032]** In Fig. 4 such a mounting and parallel guiding arrangement is shown as delivered and constitutes a basic module for use together with screening devices of various designs comprising a flexible screening member having a free end connected with an end member, e.g. as described for the embodiment in figs. 1 to 3.

**[0033]** For releasable connection with the end member of such a screening device the arrangement comprises a mounting profile designed as a mounting bar 19, which is hollow over its entire length, together with two parallel guiding cords 20 and 21 passed through the mounting bar 19, and mounting fittings 23, 24, 25 and 26 at each of the free ends of the cords 20 and 21. The free end of the cord 20 is connected with associated mounting fitting 23 through a biased spring 27, just as the free end of the cord 21 is connected with its mounting fitting 24 through a corresponding spring 28.

**[0034]** According to the invention an electric driving device 19a is built into the mounting bar 19, which driving device may be of the same design as explained

above with reference to the Figs 1 - 3, for which reason the details of the electric driving device are not shown in Figs 4 - 9.

**[0035]** An example of mounting of the arrangement shown in Fig. 4 in a window will be explained in the following with reference to Figs 5 - 9.

**[0036]** The fitting 23 is fastened to the sash of the window shown in Fig. 5, said sash comprising a bottom member 29, a top member 30 and two side members 31 and 32, by means of a fitting 33 fastened to the side member 31, close to the top member 30. The fitting 33 may, as indicated in Fig. 6, be a snap lock for releasable engagement with the fitting 23. On the opposite sash side member 32 a corresponding fitting is mounted, which is mirror-inverted relative to the fitting 33, but which is otherwise made in the same way for engagement with the fitting 24. Then the fittings 25 and 26 of the guiding arrangement are secured to respective sash side members 31 and 32 at the sash bottom member 29 by means of fittings, of which the left fitting 34 is shown in Fig. 7, said fittings being likewise made as mirror-inverted snap locks for the attainment of the position shown in Fig. 5.

**[0037]** A screening device may now in a manner known per se be fastened optionally for instance at the sash top member 30 and its screening member is pulled out from its inactive position, following which the end member such as the bottom bar, profile rail or list of the screening device are connected with the mounting bar 19, for instance by means of clamps. During the movement of a screening device mounted in this manner, the bottom bar will at all time be substantially parallel to the bottom and top member of both sash and frame. The biased springs 27 and 28 keep the parallel guiding cords 20 and 21 stretched all the time. Of course, these springs do not have to be positioned as illustrated, but may for example be built into the fitting 23 itself in such a manner that they are not directly visible from the outside.

**[0038]** When the mounting and parallel guiding arrangement is used together with a blackout shade, for instance of the roller blind type, separate side guide rails 35 and 36, as shown in Fig. 8, in which the mounting and parallel guiding arrangement for the sake of clearness has been omitted, may with a view to increasing the light-tightness be mounted on the sash side members 31 and 32. The lower ends of the guide rails 35 and 36 may for instance be connected with the lower fittings 34, and having been adjusted to the upper fittings 33 the rails 35 and 36 are screwed to the sash side members 31 and 32. The end member of the roller blind is subsequently introduced at the top of the rails 35 and 36 followed by a part of the screening member of the roller blind, i.e. the cloth, following which the roller bar of the roller blind together with a cover list is fastened to the upper fittings 33. Finally, the end member is, as described above, connected with the mounting bar 19 of the basic guiding module.

[0039] Alternatively, the mounting is initiated by a fastening of the lower fittings 25 and 26 of the mounting and parallel guiding arrangement to respective sash members 32, 31 at the sash bottom member 29 by means of the fittings 34.

[0040] If the screening device has not yet been mounted in the window, it is mounted with its top box, e. g. a blind cassette in case of a roller blind, at the sash top member 30.

[0041] The upper fittings 23 and 24 of the mounting and parallel guiding arrangement may now be connected with the top box of the of the screening device in that each fitting 23, 24 secures the top box to the fittings 33 of the sash side members by end members or push-in parts for the screening device.

[0042] Subsequently, the separate side guide rails 35 and 36 may be mounted and for instance fixed by means of screws, following which the bottom bar of the screening device, like above, is connected with the mounting bar in the mounting and parallel guiding arrangement.

[0043] The upper fittings 23 and 24 may also be designed in such a way that they are just coupled to the box of the screening device without retaining it to the window, for instance by snap-locking, whereby the side guide rails 35 and 36 secure the top box to the window.

[0044] A special advantage is that the mounting and parallel guiding arrangement as shown in Figs 5 - 8 will be dismountable at any time without the whole screening device having to be dismounted.

[0045] As shown in Fig. 9 the mounting bar 37 of the mounting and parallel guiding arrangement may be designed for coupling with an end member 38 of a further screening member 39, which at its other end is provided with a bottom bar, profile rail or list for securing to the sash bottom member 29.

[0046] This embodiment makes it possible to mount a double screening arrangement with two screening members 39 and 40 of different kinds, for instance an upper screening member 40 in the form of a blackout shading roller blind and a lower screening member 39 in the form of a light-permeable folding blind, both screening bodies being moved simultaneously by means of the electric driving device built into the mounting bar.

## Claims

1. A screening arrangement for a window, in particular a roof window, said screening arrangement comprising a member (5) of screening material, which in an inactive position is rolled up, folded or pleated and takes up a position in or at a horizontal frame or sash member (1) of the window, said member of screening material being at a free end connected with an end profile (7) extending in the width direction of the window, and a parallel guiding arrangement comprising two parallel guiding cords (8, 9)

which are separately passed through said end profile (7) and comprise end members protruding from each end thereof, the free ends of the end members of each cord being connected with two opposite frame or sash side members (2, 3) at an upper end of one of said side members and a lower end of the other side member, respectively, and movement of the screening member (5) between said inactive position and an active position being effected by means of an electric driving device (12-18), **characterized in that** the electric driving device (12-18) comprises at least one drive motor (16) and is positioned in connection with said end profile (7) to act on the two parallel guiding cords (8, 9) via transmission means (12-15).

2. A screening arrangement according to claim 1, **characterized in that** the two parallel guiding cords (8, 9) in the end profile (7) are passed around two respective reel members (12, 13) fastened on a common shaft (14), which through a transmission is connected with a common drive motor (16).

3. A screening arrangement according to claim 1, **characterized in that** the two parallel guiding cords in the end profile are passed around a common reel member fastened on a shaft, which through a transmission is connected with a common drive motor.

4. A screening arrangement according to claim 1, 2 or 3, **characterized in that** the electric driving device comprises a battery (17) for current supply to the drive motor (16).

5. A screening arrangement according to claim 4, **characterized in that** the electric driving device comprises a receiver (18) for remote command signals for affecting a motor control circuit for the drive motor (16).

6. A screening arrangement according to one of the preceding claims, **characterized by** means for manual or automatic uncoupling of the electric driving device at disruption of the current supply.

7. A universal mounting and parallel guiding arrangement for at least one screening device for a window, in particular a roof window, which screening device comprises a member of screening material, which in an inactive position is rolled up, folded or pleated and takes up a position in or at a horizontal frame or sash member of the window, said member of screening material being at a free end connected with an end member extending in the width direction of the window, said guiding arrangement comprising two parallel guiding cords (20, 21) each with end members having free ends fastened to mounting fittings (23-26) for connection with two opposite frame

or sash side members (31, 32) at the upper end of one of said side members and at a lower end of the other side member, respectively, **characterized in that** it comprises a mounting profile (19) for releasable connection with said end member, said parallel guiding cords being passed separately through said mounting profile (19), with said end members protruding from respective ends of said mounting profile (19), and that an electric driving device (19a) acting on the two parallel guiding cords (20, 21) is mounted in connection with the mounting profile (19).

8. A mounting and parallel guiding arrangement according to claim 7, **characterized in that** the electric driving device (19a) comprises at least one drive motor, which is connected with the two parallel guiding cords via transmission means.
9. A mounting and parallel guiding arrangement according to claim 8, **characterized in that** the two parallel guiding cords (20, 21) in the mounting profile (19) are passed around two respective reel members fastened on a common shaft, which via a transmission is connected with a common drive motor.
10. A mounting and parallel guiding arrangement according to claim 8, **characterized in that** the two parallel guiding cords in the mounting profile are passed around a common reel member fastened on a shaft, which via a transmission is connected with a common drive motor.
11. A mounting and parallel guiding arrangement according to claim 8, 9 or 10, **characterized in that** the electric driving device (19a) comprises a battery for supply of current to the driving motor.
12. A mounting and parallel guiding arrangement according to any claim 8 to 11, **characterized in that** the electric driving device (19a) comprises a receiver for remote command signals for affecting a motor control circuit for the drive motor.
13. A mounting and parallel guiding arrangement according to any of the claims 7 to 12, **characterized in** being provided with means for manual or automatic uncoupling of the electric driving device at disruption of current supply.
14. A mounting and parallel guiding arrangement according to any of the claims 7 to 13, **characterized in that** one of the free ends of each parallel guiding cord (20, 21) is connected with the associated mounting fitting (23, 24) by a biased spring (27, 28).
15. A mounting and parallel guiding arrangement ac-

ording to any of the claims 7 to 14, **characterized in that** the releasable connection of the mounting profile (19) with said end member is made by means of clamps.

16. A mounting and parallel guiding arrangement according to any of the claims 7 to 15, **characterized in that** the mounting fittings (23-26) comprise a pre-mountable fixed fitting (33, 34) for fastening on a frame or sash side member (31, 32) and a connection fitting (23-26) connected with the respective free end of the cord, said connection fitting being designed for snap locking with the fixed fitting (33, 34).
17. A mounting and parallel guiding arrangement according to any of the claims 7 to 16 for use in a roller blind used as a blackout shade, **characterized in that** it further comprises light-tight side guide rails (35, 36) for mounting on the opposite frame or sash side members.
18. A mounting and parallel guiding arrangement according to claim 17, **characterized in that** said side guide rails (35, 36) are adapted to be connected with at least one mounting fitting (23-26).
19. A mounting and parallel guiding arrangement according to any of the claims 6 to 18, **characterized in that** the mounting profile (37) is designed for connection with two end profiles (38) for two separate screening devices (39, 40) which in said inactive position take up positions at the top member (30) and the bottom member (29), respectively, of the frame or the sash.

#### Patentansprüche

1. Abschirmvorrichtung für ein Fenster, insbesondere ein Dachfenster, welche Abschirmvorrichtung ein Stück (5) aus Abschirmmaterial umfasst, das in einer inaktiven Stellung aufgerollt, gefaltet oder plisziert ist und eine Position in oder bei einem waagrecht Blendrahmen- oder Flügelrahmenteil (1) des Fensters einnimmt, wobei das Stück von Abschirmmaterial an einem freien Ende mit einem sich in Breitenrichtung des Fensters erstreckenden Abschlussprofil (7) verbunden ist, sowie eine Parallelführungsvorrichtung mit zwei parallelen Führungsschnüren (8, 9), die jede für sich durch erwähntes Abschlussprofil (7) geführt werden und Endteile umfassen, die an jedem Ende des Abschlussprofils hervorstehen, wobei die freien Enden der Endteile jeder Schnur mit zwei gegenüberberliegenden Seitenteilen des Blend- oder Flügelrahmens (2, 3), und zwar an einem oberen Ende des einen Seitenteils bzw. einem unteren Ende des anderen Seitenteils

- verbunden sind, wobei Bewegung des Abschirmstückes (5) zwischen der inaktiven Stellung und einer aktiven Stellung mittels einer elektrischen Antriebseinrichtung (12-18) erfolgt, **dadurch gekennzeichnet, dass** die elektrische Antriebseinrichtung (12-18) zumindest einen Antriebsmotor (16) umfasst, und in Verbindung mit erwähntem Endprofil (7) zur Beeinflussung der zwei parallelen Führungsschnüre (8, 9) über Transmissionsorgane (12-15) angeordnet ist.
2. Abschirmvorrichtung nach Anspruch 1, **dadurch gekennzeichnet, dass** die zwei parallelen Führungsschnüre (8, 9) im Abschlussprofil (7) um zwei gesonderte auf einer gemeinsamen Welle (14) befestigte Spulen (12, 13) geführt werden, welche gemeinsame Welle durch eine Transmission an einen gemeinsamen Antriebsmotor (16) angeschlossen ist.
3. Abschirmvorrichtung nach Anspruch 1, **dadurch gekennzeichnet, dass** die zwei parallelen Führungsschnüre im Abschlussprofil um eine auf einer Welle befestigte gemeinsame Spule geführt werden, die über eine Transmission an einen gemeinsamen Antriebsmotor angeschlossen ist.
4. Abschirmvorrichtung nach Anspruch 1, **dadurch gekennzeichnet, dass** die elektrische Antriebseinrichtung eine Batterie (17) für Stromversorgung zum Antriebsmotor (16) umfasst.
5. Abschirmvorrichtung nach Anspruch 4, **dadurch gekennzeichnet, dass** die elektrische Antriebseinrichtung einen Empfänger (18) für Fernbedienungssignale zum Beeinflussen eines Motorsteuerstromkreises für den Antriebsmotor (16) umfasst.
6. Abschirmvorrichtung nach einem der vorhergehenden Ansprüche, **gekennzeichnet durch** Mittel zum manuellen oder automatischen Entkoppeln der elektrischen Antriebseinrichtung bei Unterbrechung der Stromversorgung.
7. Universelle Befestigungs- und Parallelführungsvorrichtung für zumindest eine Abschirmvorrichtung für ein Fenster, insbesondere ein Dachfenster, welche Abschirmvorrichtung ein Stück aus Abschirmmaterial umfasst, das in einer inaktiven Stellung aufgerollt, gefaltet oder plissiert ist und eine Position in oder bei einem waagrechten Blendrahmen- oder Flügelrahmenteil des Fensters einnimmt, welches Stück Abschirmmaterial an einem freien Ende mit einem in Breitenrichtung des Fensters verlaufenden Abschlusselement verbunden ist, wobei die Führungsvorrichtung zwei parallele Führungsschnüre (20, 21) mit Endteilen umfasst, deren freie Enden an Montagebeschläge (23-26) zur Verbindung mit zwei gegenüberliegenden Blend- oder Flügelrahmenseitenteilen (31, 32), und zwar am oberen Ende des einen Seitenteils bzw. am unteren Ende des anderen Seitenteils befestigt sind, **dadurch gekennzeichnet, dass** es ein Montageprofil (19) für auslösbare Verbindung mit dem Abschlusselement umfasst, wobei die parallelen Führungsschnüre jede für sich durch das Montageprofil (19), dessen Endteile aus den betreffenden Enden des Montageprofils (19) hervorstehen, geführt werden, und dass in Verbindung mit dem Montageprofil (19) eine die zwei parallelen Führungsschnüre (20, 21) beeinflussende elektrische Antriebseinrichtung (19a) montiert wird.
8. Befestigungs- und Parallelführungsvorrichtung nach Anspruch 7, **dadurch gekennzeichnet, dass** die elektrische Antriebseinrichtung (19a) zumindest einen Antriebsmotor umfasst, der über Transmissionsorgane mit den zwei Parallelführungsschnüren verbunden ist.
9. Befestigungs- und Parallelführungsvorrichtung nach Anspruch 8, **dadurch gekennzeichnet, dass** die zwei Parallelführungsschnüre (20, 21) im Montageprofil (19) um ihre zugehörige, auf einer gemeinsamen Welle befestigte Spule geführt werden, welche gemeinsame Welle über eine Transmission an einen gemeinsamen Antriebsmotor angeschlossen ist.
10. Befestigungs- und Parallelführungsvorrichtung nach Anspruch 8, **dadurch gekennzeichnet, dass** die zwei Parallelführungsschnüre im Montageprofil um eine auf einer Welle befestigte gemeinsame Spule geführt werden, welche Welle über eine Transmission an einen gemeinsamen Antriebsmotor angeschlossen ist.
11. Befestigungs- und Parallelführungsvorrichtung nach Anspruch 8, 9 oder 10, **dadurch gekennzeichnet, dass** die elektrische Antriebseinrichtung (19a) eine Batterie für Stromversorgung zum Antriebsmotor umfasst.
12. Befestigungs- und Parallelführungsvorrichtung nach einem der Ansprüche 8-11, **dadurch gekennzeichnet, dass** die elektrische Antriebseinrichtung (19a) einen Empfänger für Fernbedienungssignale zum Beeinflussen eines Motorsteuerstromkreises für den Antriebsmotor umfasst.
13. Befestigungs- und Parallelführungsvorrichtung nach einem der Ansprüche 7-12, **dadurch gekennzeichnet, dass** Mittel zum manuellen oder automatischen Entkoppeln der elektrischen Antriebseinrichtung bei Unterbrechung der Stromzufuhr vorgesehen sind.

14. Befestigungs- und Parallelführungsvorrichtung nach einem der Ansprüche 7-13, **dadurch gekennzeichnet, dass** eines der freien Enden jeder Parallelführungsschnur (20, 21) durch eine vorgespannte Feder (27, 28) mit dem zugehörigen Montagebeschlag (23, 24) verbunden ist. 5
15. Befestigungs- und Parallelführungsvorrichtung nach einem der Ansprüche 7-14, **dadurch gekennzeichnet, dass** die auslösbare Verbindung des Montageprofils (19) mit dem Abschlusselement mit Hilfe von Klammern hergestellt ist. 10
16. Befestigungs- und Parallelführungsvorrichtung nach einem der Ansprüche 7-15, **dadurch gekennzeichnet, dass** die Montagebeschläge (23-26) einen vormontierbaren festen Beschlag (33, 34) zum Befestigen an einem Blendrahmen- oder Flügelrahmenseitenstück (31, 32) sowie einen mit dem betreffenden freien Ende der Schnur verbundenen Kopplungsbeschlag (23-26) umfassen, welcher Kopplungsbeschlag als Schnappverschluss mit dem festen Beschlag (33, 34) ausgebildet ist. 20
17. Befestigungs- und Parallelführungsvorrichtung nach einem der Ansprüche 7-16 zur Verwendung in einem als Abdunkelung benutzten Rollo, **dadurch gekennzeichnet, dass** die Vorrichtung ferner lichtundurchlässige Seitenführungsschienen (35, 37) zum Montieren auf den gegenüberliegenden Blendrahmen- oder Flügelrahmenseitenteilen umfasst. 25
18. Befestigungs- und Parallelführungsvorrichtung nach Anspruch 17, **dadurch gekennzeichnet, dass** erwähnte Seitenführungsschienen (35, 36) zum Verbinden mit zumindest einem Montagebeschlag (23-26) vorgesehen sind. 30
19. Befestigungs- und Parallelführungsvorrichtung nach einem der Ansprüche 6-18, **dadurch gekennzeichnet, dass** das Montageprofil (37) zum Verbinden mit zwei Abschlussprofilen (38) für zwei separate Abschirmvorrichtungen (39, 40) ausgeführt ist, welche separate Abschirmvorrichtungen in der inaktiven Stellung Positionen am Oberteil (30) bzw. am Unterteil (29) des Blendrahmens oder Flügelrahmens einnehmen. 40

## Revendications

1. Dispositif d'écran pour une fenêtre, en particulier une fenêtre de toit, dispositif d'écran qui comprend un élément (5) de matériau d'écran qui, dans une position inactive, est enroulé, plié ou plissé et occupe une position dans ou à une partie de cadre ou d'ouvrant (1) de la fenêtre, ledit élément de matériau d'écran étant à un bout libre relié à un profilé d'extrémité (7) s'étendant dans la direction de largeur de la fenêtre, et un arrangement de guidage parallèle comprenant deux cordons de guidage parallèle (8, 9) qui sont guidés séparément à travers ledit profilé d'extrémité (7) et comprennent deux portions terminales faisant saillie depuis de chacun des bouts de celui-ci, les bouts libres des portions terminales de chaque cordon étant reliés à deux parties latérales et opposées de cadre ou d'ouvrant (2, 3) respectivement à un bout supérieur de l'une desdites parties latérales et à un bout inférieur de l'autre partie latérale, le mouvement de l'élément d'écran (5) entre ladite position inactive et une position active étant effectué au moyen d'un mécanisme d'entraînement électrique (12-18), **caractérisé en ce que** le mécanisme d'entraînement électrique (12-18) comprend au moins un moteur d'entraînement (16) et est positionné en liaison avec ledit profilé d'extrémité (7) pour agir sur les deux cordons de guidage parallèle (8, 9) via des moyens de transmission (12-15). 55
2. Dispositif d'écran selon la revendication 1, **caractérisé en ce que** les deux cordons de guidage parallèle (8, 9) dans le profilé d'extrémité (7) sont passés autour de deux éléments de poulie (12, 13) respectifs et fixés sur un arbre commun (14) relié à un moteur d'entraînement (16) par une transmission.
3. Dispositif d'écran selon la revendication 1, **caractérisé en ce que** les deux cordons de guidage parallèle dans le profilé d'extrémité sont passés autour d'un élément de poulie commun et fixé sur un arbre relié à un moteur d'entraînement commun par une transmission.
4. Dispositif d'écran selon la revendication 1, 2 ou 3, **caractérisé en ce que** le mécanisme d'entraînement électrique comprend une pile (17) pour l'alimentation de courant au moteur d'entraînement (16).
5. Dispositif d'écran selon la revendication 4, **caractérisé en ce que** le mécanisme d'entraînement électrique comprend un récepteur (18) pour des signaux de télécommande à agir sur un circuit de commande de moteur pour le moteur d'entraînement (16).
6. Dispositif d'écran selon l'une quelconque des revendications précédentes, **caractérisé par** des moyens pour débrayage manuel ou automatique du mécanisme d'entraînement électrique à coupure de l'alimentation de courant.
7. Arrangement universel de montage et de guidage parallèle pour au moins un dispositif d'écran d'une fenêtre, en particulier une fenêtre de toit, dispositif



- d'écran qui comprend un élément de matériau d'écran qui, dans une position inactive, est enroulé, plié ou plissé et occupe une position dans ou à une partie horizontale de cadre ou d'ouvrant de la fenêtre, ledit élément de matériau d'écran étant à un bout libre relié à un profilé d'extrémité s'étendant dans la direction de largeur de la fenêtre, ledit un arrangement de guidage comprenant deux cordons de guidage parallèle (20, 21) chacun avec des portions terminales ayant des bouts libres fixés à des ferrures de fixation (23-26) pour liaison avec deux parties latérales opposées de cadre ou d'ouvrant (31, 32) respectivement au bout supérieur de l'une desdites parties latérales et à un bout inférieur de l'autre partie latérale, **caractérisé en ce qu'il** comprend un profilé de montage (19) pour liaison débrayable avec ladite portion terminale, lesdits cordons de guidage parallèle étant guidés séparément à travers ledit profilé de montage (19), avec lesdites portions terminales faisant saillie depuis des bouts respectifs dudit profilé de montage (19), et **en ce qu'un** mécanisme d'entraînement électrique (19a) agissant sur les deux cordons de guidage parallèle (20, 21) est monté en liaison avec le profilé de montage (19).
8. Arrangement de montage et de guidage parallèle selon la revendication 7, **caractérisé en ce que** le mécanisme d'entraînement électrique (19a) comprend au moins un moteur d'entraînement relié aux deux cordons de guidage parallèle via des moyens de transmission.
9. Arrangement de montage et de guidage parallèle selon la revendication 8, **caractérisé en ce que** les deux cordons de guidage parallèle (20, 21) dans le profilé de montage (19) sont passés autour de deux éléments de poulie respectifs fixés sur un arbre commun relié via une transmission à un moteur d'entraînement commun.
10. Arrangement de montage et de guidage parallèle selon la revendication 8, **caractérisé en ce que** les deux cordons de guidage parallèle dans le profilé de montage sont passés autour d'un élément de poulie commun fixé sur un arbre qui est relié via une transmission à un moteur d'entraînement commun.
11. Arrangement de montage et de guidage parallèle selon la revendication 8, 9 ou 10, **caractérisé en ce que** le mécanisme d'entraînement électrique (19a) comprend une pile pour l'alimentation de courant au moteur d'entraînement.
12. Arrangement de montage et de guidage parallèle selon l'une quelconque des revendications 8-11, **caractérisé en ce que** le mécanisme d'entraînement électrique (19a) comprend un récepteur pour des signaux de télécommande à agir sur un circuit de commande de moteur pour le moteur d'entraînement.
13. Arrangement de montage et de guidage parallèle selon l'une quelconque des revendications 7-12, **caractérisé en étant** pourvu de moyens pour débrayage manuel ou automatique du mécanisme d'entraînement électrique à coupure de l'alimentation de courant.
14. Arrangement de montage et de guidage parallèle selon l'une quelconque des revendications 7-13, **caractérisé en ce que** l'un des bouts libres de chaque cordon de guidage parallèle (20, 21) est relié à la ferrure de montage associée (23, 24) par un ressort à tension initiale (27, 28).
15. Arrangement de montage et de guidage parallèle selon l'une quelconque des revendications 7-14, **caractérisé en ce que** la liaison débrayable du profilé de montage (19) avec ladite portion terminale est effectuée au moyen d'attaches.
16. Arrangement de montage et de guidage parallèle selon l'une quelconque des revendications 7-15, **caractérisé en ce que** les ferrures de montage (23-26) comprennent une ferrure fixe à prémontage (33, 34) pour fixation sur une partie latérale de cadre ou d'ouvrant (31, 32) et une ferrure d'embrayage (23-26) reliée au bout libre respectif du cordon, ladite ferrure d'embrayage étant conçue pour encliquetage avec les ferrures fixes (33, 34).
17. Arrangement de montage et de guidage parallèle selon l'une quelconque des revendications 7-16 à l'usage dans un store roulant utilisé comme un store d'occultation, **caractérisé en ce qu'il** comprend de plus des rails de guidage latéraux et étanches à la lumière (35, 36) à monter sur les parties latérales opposées de cadre ou d'ouvrant.
18. Arrangement de montage et de guidage parallèle selon la revendication 17, **caractérisé en ce que** lesdits rails de guidage latéraux (35, 36) sont adaptés à lier avec au moins l'une ferrure de montage (23-26).
19. Arrangement de montage et de guidage parallèle selon l'une quelconque des revendications 6-18, **caractérisé en ce que** le profilé de montage (37) est conçu pour liaison avec deux profilés d'extrémité (38) de deux dispositifs d'écran séparés (39, 40) qui, dans ladite position inactive, occupent des positions respectivement à la partie supérieure (30) et à la partie inférieure (29) du cadre ou de l'ouvrant.

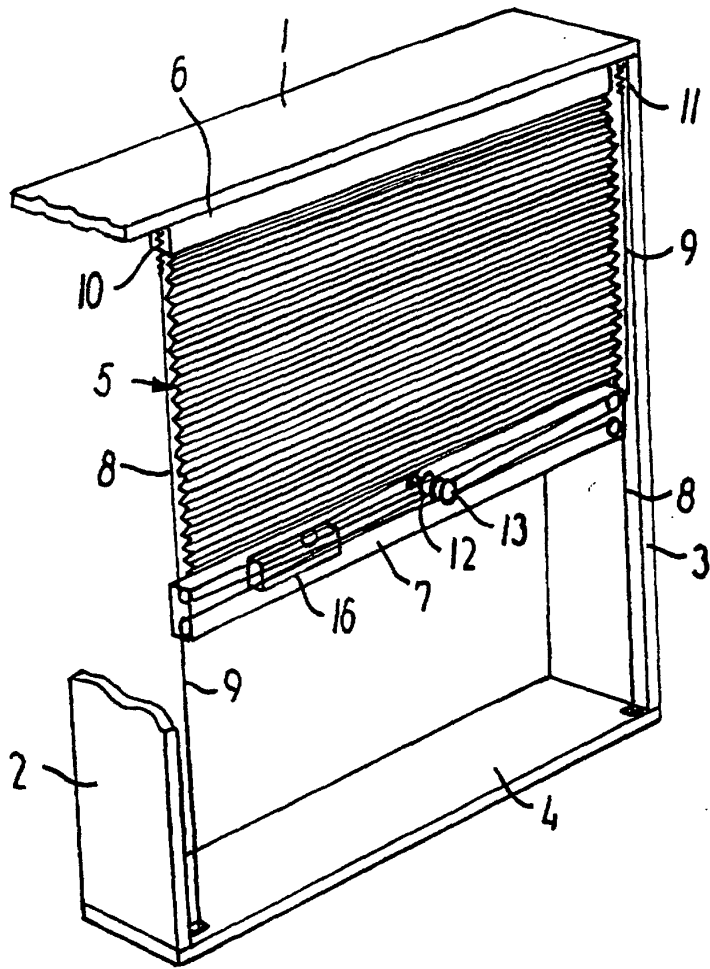

FIG. 1

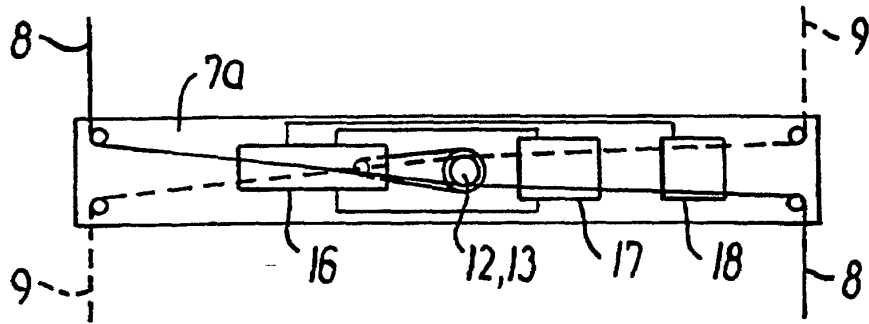

FIG. 2

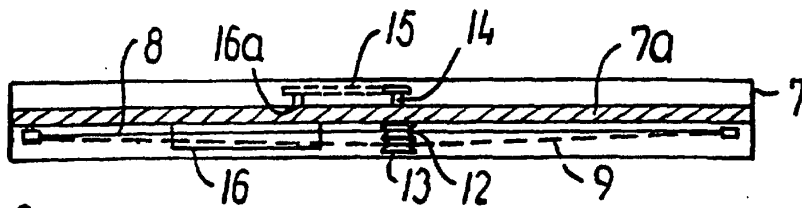

FIG. 3

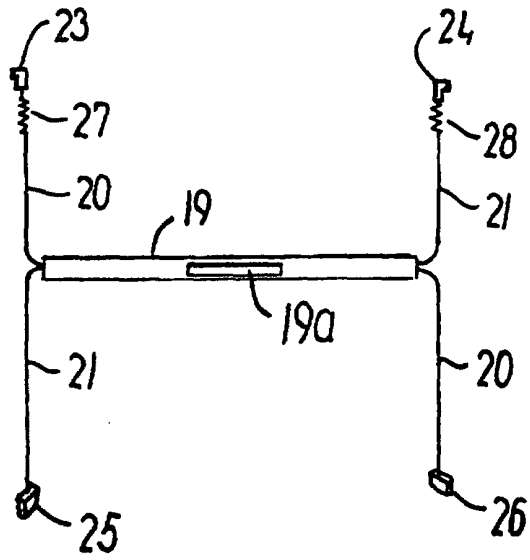

FIG. 4

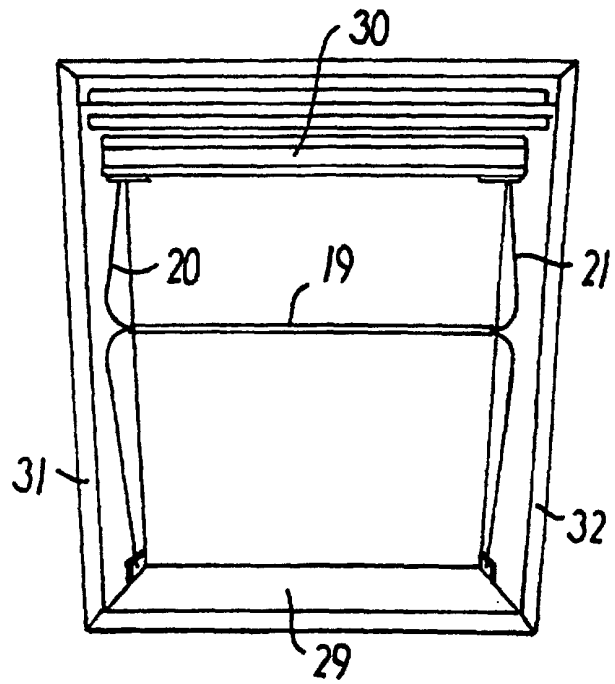

FIG. 5

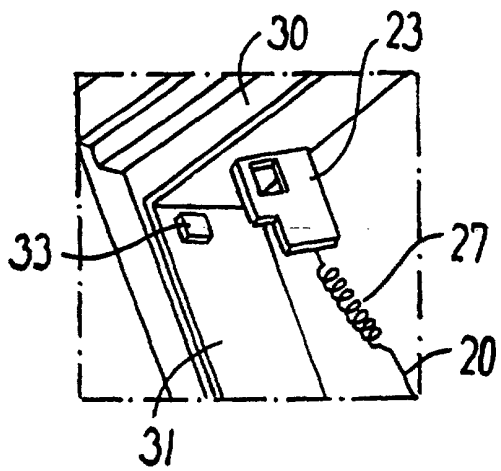

FIG. 6

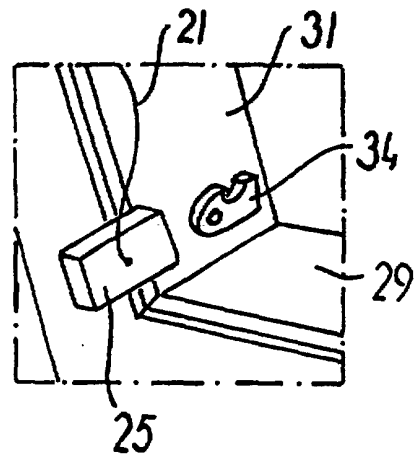

FIG. 7

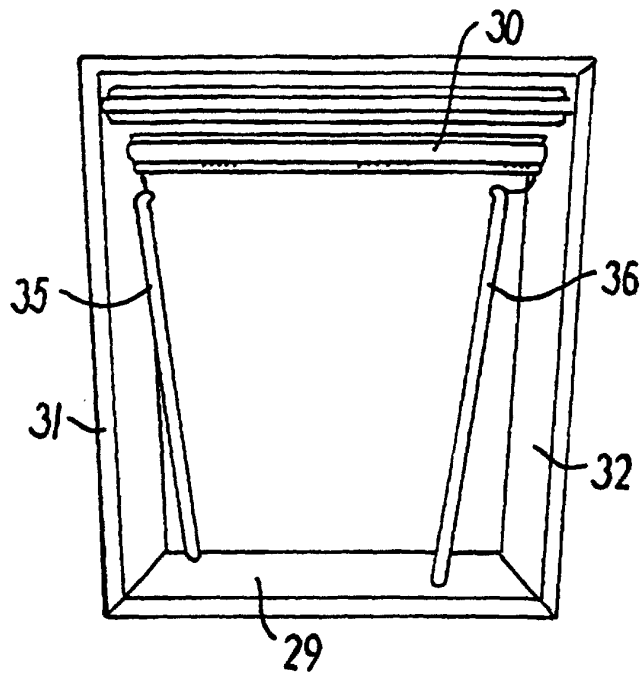

FIG. 8

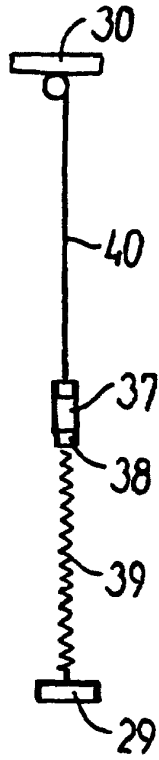

FIG. 9