

**(12) STANDARD PATENT**  
**(19) AUSTRALIAN PATENT OFFICE**

(11) Application No. **AU 2004228065 B2**

(54) Title  
**Water-based dithiolene infrared inkjet inks**

(51) International Patent Classification(s)  
**C09B 57/10** (2006.01)                      **G06F 17/30** (2006.01)  
**B41J 2/01** (2006.01)                      **G06F 19/00** (2006.01)  
**C09B 49/12** (2006.01)                      **G06K 5/00** (2006.01)  
**C09D 11/00** (2006.01)                      **G06K 7/00** (2006.01)  
**C09D 11/02** (2006.01)                      **G06K 7/10** (2006.01)  
**D21H 19/38** (2006.01)                      **G06K 7/14** (2006.01)  
**G01N 33/48** (2006.01)                      **G06K 9/00** (2006.01)  
**G01N 33/50** (2006.01)                      **G06K 9/18** (2006.01)  
**G05B 15/00** (2006.01)                      **G06K 9/20** (2006.01)  
**G06F 3/08** (2006.01)                      **G06K 9/22** (2006.01)  
**G06F 7/00** (2006.01)                      **G06K 9/78** (2006.01)  
**G06F 7/02** (2006.01)                      **G06K 15/00** (2006.01)  
**G06F 7/08** (2006.01)                      **G06K 19/06** (2006.01)  
**G06F 15/00** (2006.01)                      **H04N 1/04** (2006.01)  
**G06F 17/00** (2006.01)

(21) Application No: **2004228065**                      (22) Date of Filing: **2004.04.02**

(87) WIPO No: **WO04/090047**

(30) Priority Data

(31) Number	(32) Date	(33) Country
<b>2003901617</b>	<b>2003.04.07</b>	<b>AU</b>
<b>2003901795</b>	<b>2003.04.15</b>	<b>AU</b>

(43) Publication Date: **2004.10.21**

(44) Accepted Journal Date: **2007.07.05**

(71) Applicant(s)  
**Silverbrook Research Pty Ltd**

(72) Inventor(s)  
**Starling, Scott Matthew;Papadakis, Alexandra Artemis;Lapstun, Paul;Vonwiller, Simone Charlotte;Ridley, Damon Donald;Hall, Lachlan Everett;Silverbrook, Kia**

(74) Agent / Attorney  
**Silverbrook Research Pty Ltd, 393 Darling Street, Balmain, ACT, 2041**

(56) Related Art  
**US 5282894**

(19) World Intellectual Property  
Organization  
International Bureau



(43) International Publication Date  
21 October 2004 (21.10.2004)

PCT

(10) International Publication Number  
WO 2004/090047 A1

(51) International Patent Classification<sup>7</sup>: C09B 57/10,  
49/12, C09D 11/02, B41J 2/01, D21H 19/38, G06F 3/08

Kia [AU/AU]; Silverbrook Research Pty Ltd, 393 Darling Street, Balmain, New South Wales 2041 (AU). LAMPSTUN, Paul [NO/AU]; Silverbrook Research Pty Ltd, 393 Darling Street, Balmain, New South Wales 2041 (AU).

(21) International Application Number:  
PCT/AU2004/000436

(74) Agent: SILVERBROOK, Kia; Silverbrook Research Pty Ltd, 393 Darling Street, Balmain, New South Wales 2041 (AU).

(22) International Filing Date: 2 April 2004 (02.04.2004)

(25) Filing Language: English

(81) Designated States (unless otherwise indicated, for every kind of national protection available): AE, AG, AL, AM, AT, AU, AZ, BA, BB, BG, BR, BW, BY, BZ, CA, CH, CN, CO, CR, CU, CZ, DE, DK, DM, DZ, EC, EE, EG, ES, FI, GB, GD, GE, GH, GM, HR, HU, ID, IL, IN, IS, JP, KE, KG, KP, KR, KZ, LC, LK, LR, LS, LT, LU, LV, MA, MD, MG, MK, MN, MW, MX, MZ, NA, NI, NO, NZ, OM, PG, PH, PL, PT, RO, RU, SC, SD, SE, SG, SK, SL, SY, TJ, TM, TN, TR, TT, TZ, UA, UG, US, UZ, VC, VN, YU, ZA, ZM, ZW.

(26) Publication Language: English

(30) Priority Data:  
2003901617 7 April 2003 (07.04.2003) AU  
2003901795 15 April 2003 (15.04.2003) AU

(71) Applicant (for all designated States except US): SILVERBROOK RESEARCH PTY LTD [AU/AU]; 393 Darling Street, Balmain, New South Wales 2041 (AU).

(72) Inventors; and

(75) Inventors/Applicants (for US only): HALL, Lachlan, Everett [AU/AU]; Silverbrook Research Pty Ltd, 393 Darling Street, Balmain, New South Wales 2041 (AU). PAPADAKIS, Alexandra, Artemis [AU/AU]; Silverbrook Research Pty Ltd, 393 Darling Street, Balmain, New South Wales 2041 (AU). RIDLEY, Damon, Donald [AU/AU]; Silverbrook Research Pty Ltd, 393 Darling Street, Balmain, New South Wales 2041 (AU). STARLING, Scott, Matthew [AU/AU]; Silverbrook Research Pty Ltd, 393 Darling Street, Balmain, New South Wales 2041 (AU). VONWILLER, Simone, Charlotte [AU/AU]; Silverbrook Research Pty Ltd, 393 Darling Street, Balmain, New South Wales 2041 (AU). SILVERBROOK,

(84) Designated States (unless otherwise indicated, for every kind of regional protection available): ARIPO (BW, GH, GM, KE, LS, MW, MZ, SD, SL, SZ, TZ, UG, ZM, ZW), Eurasian (AM, AZ, BY, KG, KZ, MD, RU, TJ, TM), European (AT, BE, BG, CH, CY, CZ, DE, DK, EE, ES, FI, FR, GB, GR, HU, IE, IT, LU, MC, NL, PL, PT, RO, SE, SI, SK, TR), OAPI (BF, BJ, CF, CG, CI, CM, GA, GN, GQ, GW, ML, MR, NE, SN, TD, TG).

Published:

— with international search report

For two-letter codes and other abbreviations, refer to the "Guidance Notes on Codes and Abbreviations" appearing at the beginning of each regular issue of the PCT Gazette.



WO 2004/090047 A1

(54) Title: WATER-BASED DITHIOLENE INFRARED INKJET INKS

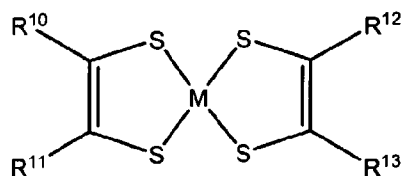

(01I)

(57) Abstract: The present invention provides an IR-absorbing dye suitable for formulating a water-based inkjet ink, said dye being of formula (01I) wherein: M is selected from Ni, Pd or Pt; R<sup>10</sup> and R<sup>11</sup> are independently selected from C<sub>1-30</sub> hydrocarbyl, or R<sup>10</sup> and R<sup>11</sup> together are joined to form a C<sub>2-30</sub> hydrocarbylene group; R<sup>12</sup> and R<sup>13</sup> are independently selected from C<sub>1-30</sub> hydrocarbyl, or R<sup>12</sup> and R<sup>13</sup> together are joined to form a C<sub>2-30</sub> hydrocarbylene group; wherein at least one of

R<sup>10</sup>, R<sup>11</sup>, R<sup>12</sup> or R<sup>13</sup> comprises a hydrophilic group. Dyes of this type are especially suitable for use in netpage and Hyperlabel systems.

## WATER-BASED DITHIOLENE INFRARED INKJET INKS

### Field of the Invention

The present application relates to water-based infrared inkjet inks and dithiolene dyes  
5 suitable for formulating such inks. It has been developed primarily to allow high-speed, high-  
throughput printing of dithiolene IR inks.

Various methods, systems and apparatus relating to the present invention are disclosed in the  
following co-pending applications filed by the applicant or assignee of the present invention  
10 simultaneously with the present application:

HYC PCT,      HYT PCT,      HYG PCT,      HYJ PCT,      HYD PCT

The disclosures of these co-pending applications are incorporated herein by cross-reference.  
15 Each application is temporarily identified by its docket number. This will be replaced by the  
corresponding application numbers when available.

### Background of the Invention

IR absorbing dyes have numerous applications, such as optical recording systems,  
20 thermal writing displays, laser filters, infrared photography, medical applications and printing.  
Typically, it is desirable for the dyes used in these applications to have strong absorption in the  
near-IR at the emission wavelengths of semiconductor lasers (*e.g.* between about 700 and 2000  
nm, preferably between about 700 and 1000 nm). In optical recording technology, for example,  
gallium aluminium arsenide (GaAlAs) and indium phosphide (InP) diode lasers are widely  
25 used as light sources.

Another important application of IR dyes is in inks, such as printing inks. The storage  
and retrieval of digital information in printed form is particularly important. A familiar  
example of this technology is the use of printed, scannable bar codes. Bar codes are typically  
printed onto tags or labels associated with a particular product and contain information about  
30 the product, such as its identity, price *etc.* Bar codes are usually printed in lines of visible black  
ink, and detected using visible light from a scanner. The scanner typically comprises an LED

or laser (e.g. a HeNe laser, which emits light at 633 nm) light source and a photocell for detecting reflected light. Black dyes suitable for use in barcode inks are described in, for example, WO03/074613.

However, in other applications of this technology (e.g. security tagging) it is desirable to have a barcode, or other intelligible marking, printed with an ink that is invisible to the unaided eye, but which can be detected under UV or IR light.

An especially important application of detectable invisible ink is in automatic identification systems, and especially "netpage" and "Hyperlabel<sup>TM</sup>" systems. Netpage systems are described in the following patent applications, all of which are incorporated herein by reference.

An especially important application of detectable invisible ink is in automatic identification systems, and especially "netpage" and "Hyperlabel<sup>TM</sup>" systems. Netpage systems are described in the following patent applications, all of which are incorporated herein by reference.

	10/409,876	10/409,848	10/409,845	09/575,197	09/575,195
	09/575,159	09/575,132	09/575,123	09/575,148	09/575,130
	09/575,165	09/575,153	09/693,415	09/575,118	09/609,139
20	09/608,970	09/575,116	09/575,144	09/575,139	09/575,186
	09/575,185	09/609,039	09/663,579	09/663,599	09/607,852
	09/575,191	09/693,219	09/575,145	09/607,656	09/693,280
	09/609,132	09/693,515	09/663,701	09/575,192	09/663,640
	09/609,303	09/610,095	09/609,596	09/693,705	09/693,647
25	09/721,895	09/721,894	09/607,843	09/693,690	09/607,605
	09/608,178	09/609,553	09/609,233	09/609,149	09/608,022
	09/575,181	09/722,174	09/721,896	10/291,522	10/291,517
	10/291,523	10/291,471	10/291,470	10/291,819	10/291,481
	10/291,509	10/291,825	10/291,519	10/291,575	10/291,557
30	10/291,661	10/291,558	10/291,587	10/291,818	10/291,576
	10/291,589	10/291,526	6,644,545	6,609,653	6,651,879
	10/291,555	10/291,510	19/291,592	10/291,542	10/291,820
	10/291,516	10/291,363	10/291,487	10/291,520	10/291,521
	10/291,556	10/291,821	10/291,525	10/291,586	10/291,822

	10/291,524	10/291,553	10/291,511	10/291,585	10/291,374
	10/685,523	10/685,583	10/685,455	10/685,584	NPA133US
	09/575,193	09/575,156	09/609,232	09/607,844	09/607,657
	09/693,593	NPB008US	09/928,055	09/927,684	09/928,108
5	09/927,685	09/927,809	09/575,183	09/575,160	09/575,150
	09/575,169	6,644,642	6,502,614	6,622,999	09/575,149
	10/322,450	6,549,935	NPN004US	09/575,187	09/575,155
	6,591,884	6,439,706	09/575,196	09/575,198	09/722,148
	09/722,146	09/721,861	6,290,349	6,428,155	09/575,146
10	09/608,920	09/721,892	09/722,171	09/721,858	09/722,142
	10/171,987	10/202,021	10/291,724	10/291,512	10/291,554
	10/659,027	10/659,026	09/693,301	09/575,174	09/575,163
	09/693,216	09/693,341	09/693,473	09/722,087	09/722,141
	09/722,175	09/722,147	09/575,168	09/722,172	09/693,514
15	09/721,893	09/722,088	10/291,578	10/291,823	10/291,560
	10/291,366	10/291,503	10/291,469	10/274,817	09/575,154
	09/575,129	09/575,124	09/575,188	09/721,862	10/120,441
	10/291,577	10/291,718	10/291,719	10/291,543	10/291,494
	10/292,608	10/291,715	10/291,559	10/291,660	10/409,864
20	10/309,358	10/410,484	10/683,151	10/683,040	09/575,189
	09/575,162	09/575,172	09/575,170	09/575,171	09/575,161
	10/291,716	10/291,547	10/291,538	10/291,717	10/291,827
	10/291,548	10/291,714	10/291,544	10/291,541	10/291,584
	10/291,579	10/291,824	10/291,713	10/291,545	10/291,546
25	09/693,388	09/693,704	09/693,510	09/693,336	09/693,335
	10/181,496	10/274,119	10/309,185	10/309,066	NPW014US
	NPS047US	NPS048US	NPS049US	NPS050US	NPS051US
	NPS052US	NPS053US	NPS054US	NPS045US	NPS046US
	NPT037US	NPA138US	NPA136US		

30

Some applications are temporarily identified by their docket number. This will be replaced by the corresponding application number when available.

In general, the netpage system relies on the production of, and human interaction with, netpages. These are pages of text, graphics and images printed on ordinary paper, but which work like interactive web pages. Information is encoded on each page using ink which is

35

substantially invisible to the unaided human eye. The ink, however, and thereby the coded data, can be sensed by an optically imaging pen and transmitted to the netpage system.

Active buttons and hyperlinks on each page may be clicked with the pen to request information from the network or to signal preferences to a network server. In some forms, text  
5 written by hand on a netpage may be automatically recognized and converted to computer text in the netpage system, allowing forms to be filled in. In other forms, signatures recorded on a netpage may be automatically verified, allowing e-commerce transactions to be securely authorized.

Netpages are the foundation on which a netpage network is built. They may provide a  
10 paper-based user interface to published information and interactive services.

A netpage consists of a printed page (or other surface region) invisibly tagged with references to an online description of the page. The online page description is maintained persistently by a netpage page server. The page description describes the visible layout and content of the page, including text, graphics and images. It also describes the input elements on  
15 the page, including buttons, hyperlinks, and input fields. A netpage allows markings made with a netpage pen on its surface to be simultaneously captured and processed by the netpage system.

Multiple netpages can share the same page description. However, to allow input through otherwise identical pages to be distinguished, each netpage is assigned a unique page  
20 identifier. This page ID has sufficient precision to distinguish between a very large number of netpages.

Each reference to the page description is encoded in a printed tag. The tag identifies the unique page on which it appears, and thereby indirectly identifies the page description. The tag also identifies its own position on the page.

25 Tags are printed in infrared-absorptive ink on any substrate which is infrared-reflective, such as ordinary paper. Near-infrared wavelengths are invisible to the human eye but are easily sensed by a solid-state image sensor with an appropriate filter.

A tag is sensed by an area image sensor in the netpage pen, and the tag data is transmitted to the netpage system via the nearest netpage printer. The pen is wireless and  
30 communicates with the netpage printer via a short-range radio link. Tags are sufficiently small and densely arranged that the pen can reliably image at least one tag even on a single click on

the page. It is important that the pen recognize the page ID and position on every interaction with the page, since the interaction is stateless. Tags are error-correctably encoded to make them partially tolerant to surface damage.

The netpage page server maintains a unique page instance for each printed netpage, allowing it to maintain a distinct set of user-supplied values for input fields in the page description for each printed netpage.

Hyperlabel™ is a trade mark of Silverbrook Research Pty Ltd, Australia. In general, Hyperlabel™ systems use an invisible (e.g. infrared) tagging scheme to uniquely identify a product item. This has the significant advantage that it allows the entire surface of a product to be tagged, or a significant portion thereof, without impinging on the graphic design of the product's packaging or labeling. If the entire surface of a product is tagged ("omnitagged"), then the orientation of the product does not affect its ability to be scanned *i.e.* a significant part of the line-of-sight disadvantage of visible barcodes is eliminated. Furthermore, if the tags are compact and massively replicated ("omnitags"), then label damage no longer prevents scanning.

Thus, hyperlabelling consists of covering a large portion of the surface of a product with optically-readable invisible tags. When the tags utilize reflection or absorption in the infrared spectrum, they are referred to as infrared identification (IRID) tags. Each Hyperlabel™ tag uniquely identifies the product on which it appears. The tag may directly encode the product code of the item, or it may encode a surrogate ID which in turn identifies the product code via a database lookup. Each tag also optionally identifies its own position on the surface of the product item, to provide the downstream consumer benefits of netpage interactivity.

Hyperlabels™ are applied during product manufacture and/or packaging using digital printers, preferably inkjet printers. These may be add-on infrared printers, which print the tags after the text and graphics have been printed by other means, or integrated colour and infrared printers which print the tags, text and graphics simultaneously.

Hyperlabels™ can be detected using similar technology to barcodes, except using a light source having an appropriate near-IR frequency. The light source may be a laser (e.g. a GaAlAs laser, which emits light at 830 nm) or it may be an LED.

From the foregoing, it will be readily apparent that invisible IR detectable inks are an important component of netpage and Hyperlabel™ systems. In order for an IR absorbing ink to function satisfactorily in these systems, it should ideally meet a number of criteria:

- (i) compatibility with inkjet printers;
- 5 (ii) compatibility of the IR dye with aqueous solvents used in inkjet inks;
- (iii) intense absorption in the near infra-red region (*e.g.* 700 to 1000 nm);
- (iv) zero or low intensity visible absorption;
- (v) lightfastness;
- (vi) thermal stability;
- 10 (vii) zero or low toxicity;
- (viii) low-cost manufacture;
- (ix) adheres well to paper and other media; and
- (x) no strikethrough and minimal bleeding of the ink on printing.

Hence, it would be desirable to develop IR dyes and ink compositions fulfilling at least  
15 some and preferably all of the above criteria. Such inks are desirable to complement netpage and Hyperlabel™ systems.

Some IR dyes are commercially available from various sources, such as Epolin Products, Avecia Inks and H.W. Sands Corp.

In addition, the prior art describes various IR dyes. US 5,460,646, for example,  
20 describes an infrared printing ink comprising a colorant, a vehicle and a solvent, wherein the colorant is a silicon (IV) 2,3-naphthalocyanine bis-trialkylsilyloxiide.

US 5,282,894 describes a solvent-based printing ink comprising a metal-free  
phthalocyanine, a complexed phthalocyanine, a metal-free naphthalocyanine, a complexed  
naphthalocyanine, a nickel dithiolene, an aminium compound, a methine compound or an  
25 azulenesquaric acid.

However, none of the prior art dyes can be formulated into ink compositions suitable  
for use in netpage or Hyperlabel™ systems. In particular, commercially available and/or prior  
art inks suffer from one or more of the following problems: absorption at wavelengths  
unsuitable for detection by near-IR sensors; poor solubility or dispersibility in aqueous solvent  
30 systems; or unacceptably high absorption in the visible part of the spectrum.



In a typical netpage, there may be a large number of hyperlinks on one page and correspondingly relatively large areas of the page printed with IR ink. In the Hyperlabel™ system, the majority of a product's packaging may be printed with the invisible ink. Thus, it is especially desirable that the ink used is invisible to the unaided eye and contains minimal residual colour.

Moreover, inkjet printing is the preferred means for generating netpages and Hyperlabels™. Inkjet printing is preferred primarily for its high-speed and low cost. Inkjet inks are typically water-based for reasons of low cost, low toxicity and low flammability. In thermal bubble-jet printers, the ink needs to be rapidly vaporized during the printing process. This rapid vaporization of the ink during the printing process necessitates a water-based ink composition. Accordingly, it is desirable that the IR dyes used in netpage and Hyperlabel™ inks are suitable for formulating into aqueous ink compositions and are compatible with inkjet printers.

A further essential requirement of IR dyes used in netpage systems is that they must absorb IR radiation at a frequency complementary to the frequency of the IR sensor in the netpage pen. Preferably, the ink should contain a dye, which absorbs strongly at the frequency of the IR sensor. Accordingly, the dyes used in netpage systems should absorb strongly in the near-IR region – that is, 700 to 1000 nm, preferably 750 to 900 nm, more preferably 780 to 850 nm.

## 20 Summary of the Invention

In a first aspect, the present invention provides an IR-absorbing dye suitable for formulating a water-based inkjet ink, said dye being of formula (01I):

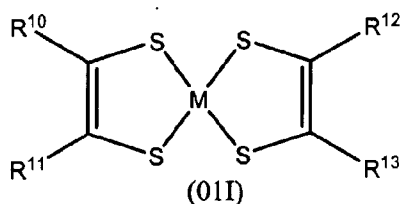

25

wherein:

M is selected from Ni, Pd or Pt (preferably Ni);

R<sup>10</sup> and R<sup>11</sup> are independently selected from C<sub>1-30</sub> hydrocarbyl, or R<sup>10</sup> and R<sup>11</sup> together are joined to form a C<sub>2-30</sub> hydrocarbylene group;

R<sup>12</sup> and R<sup>13</sup> are independently selected from C<sub>1-30</sub> hydrocarbyl, or R<sup>12</sup> and R<sup>13</sup> together are joined to form a C<sub>2-30</sub> hydrocarbylene group;

5 wherein at least one of R<sup>10</sup>, R<sup>11</sup>, R<sup>12</sup> or R<sup>13</sup> comprises a hydrophilic group.

In a second aspect, the present invention provides an inkjet ink comprising a dye as described above.

In a third aspect, the present invention provides an inkjet printer comprising a printhead in fluid communication with at least one ink reservoir, wherein said at least one ink reservoir  
10 comprises an inkjet ink as described above.

In a fourth aspect, the present invention provides an ink cartridge for an inkjet printer, wherein said ink cartridge comprises an inkjet ink as described above.

In a fifth aspect, the present invention provides a substrate having a dye as described above disposed thereon.

15 In a sixth aspect, there is provided a method of enabling entry of data into a computer system via a printed form, the form containing human-readable information and machine-readable coded data, the coded data being indicative of an identity of the form and of a plurality of reference points of the form, the method including the steps of:

receiving, in the computer system and from a sensing device, indicating data regarding  
20 the identity of the form and a position of the sensing device relative to the form, the sensing device, when placed in an operative position relative to the form, generating the indicating data using at least some of the coded data;

identifying, in the computer system and from the indicating data, at least one field of the form; and

25 interpreting, in the computer system, at least some of the indicating data as it relates to the at least one field,  
wherein said coded data comprises an IR-absorbing dye as described above.

In a seventh aspect, there is provided a method of enabling entry of data into a computer system via a printed form, the form containing human-readable information and  
30 machine-readable coded data, the coded data being indicative of at least one field of the form, the method including the steps of:

receiving, in the computer system and from a sensing device, indicating data regarding the at least one field and including movement data regarding movement of the sensing device relative to the form, the sensing device, when moved relative to the form, generating the data regarding said at least one field using at least some of the coded data and generating the data regarding its own movement relative to the form; and

interpreting, in the computer system, at least some of said indicating data as it relates to said at least one field,

wherein said coded data comprises an IR-absorbing dye as described above.

In an eighth aspect, there is provided a method of enabling entry of data into a computer system via a product item, the product item having a printed surface containing human-readable information and machine-readable coded data, the coded data being indicative of an identity of the product item, the method including the steps of:

(a) receiving, in the computer system and from a sensing device, indicating data regarding the identity of the product item, the sensing device, when placed in an operative position relative to the product item, generating the indicating data using at least some of the coded data; and

(b) recording, in the computer system and using the indicating data, information relating to the product item,

wherein said coded data comprises an IR-absorbing dye as described above.

In a ninth aspect, there is provided a method of enabling retrieval of data from a computer system via a product item, the product item having a printed surface containing human-readable information and machine-readable coded data, the coded data being indicative of an identity of the product item, the method including the steps of:

(a) receiving, in the computer system and from a sensing device, indicating data regarding the identity of the product item, the sensing device, when placed in an operative position relative to the product item, generating the indicating data using at least some of the coded data;

(b) retrieving, in the computer system and using the indicating data, information relating to the product item; and

(c) outputting, from the computer system and to an output device, the information relating to the product item, the output device selected from the group comprising a display device and a printing device,

wherein said coded data comprises an IR-absorbing dye as described above.

5 In a tenth aspect, the present invention provides a stabilized ink composition comprising an IR-absorbing metal-dithiolene dye and a singlet oxygen quencher.

In an eleventh aspect, the present invention provides a stabilized inkjet ink comprising an IR-absorbing metal-dithiolene dye and a singlet oxygen quencher.

10 In a twelfth aspect, the present invention provides an inkjet printer comprising a printhead in fluid communication with at least one ink reservoir, wherein said at least one ink reservoir comprises an inkjet ink as described above.

In a thirteenth aspect, the present invention provides an ink cartridge for an inkjet printer, wherein said ink cartridge comprises an inkjet ink as described above.

15 In a fourteenth aspect, the present invention provides a substrate having an ink composition as described above disposed thereon.

In a fifteenth aspect, there is provided a method of enabling entry of data into a computer system via a printed form, the form containing human-readable information and machine-readable coded data, the coded data being indicative of an identity of the form and of a plurality of reference points of the form, the method including the steps of:

20 receiving, in the computer system and from a sensing device, indicating data regarding the identity of the form and a position of the sensing device relative to the form, the sensing device, when placed in an operative position relative to the form, generating the indicating data using at least some of the coded data;

25 identifying, in the computer system and from the indicating data, at least one field of the form; and

interpreting, in the computer system, at least some of the indicating data as it relates to the at least one field,

wherein said coded data comprises an ink composition as described above.

30 In a sixteenth aspect, there is provided a method of enabling entry of data into a computer system via a printed form, the form containing human-readable information and

machine-readable coded data, the coded data being indicative of at least one field of the form, the method including the steps of:

receiving, in the computer system and from a sensing device, indicating data regarding the at least one field and including movement data regarding movement of the sensing device relative to the form, the sensing device, when moved relative to the form, generating the data regarding said at least one field using at least some of the coded data and generating the data regarding its own movement relative to the form; and

interpreting, in the computer system, at least some of said indicating data as it relates to said at least one field,  
10 wherein said coded data comprises an ink composition as described above.

In a seventeenth aspect, there is provided a method of enabling entry of data into a computer system via a product item, the product item having a printed surface containing human-readable information and machine-readable coded data, the coded data being indicative of an identity of the product item, the method including the steps of:

15 (a) receiving, in the computer system and from a sensing device, indicating data regarding the identity of the product item, the sensing device, when placed in an operative position relative to the product item, generating the indicating data using at least some of the coded data; and

(b) recording, in the computer system and using the indicating data, information relating to the product item,  
20 wherein said coded data comprises an ink composition as described above.

In an eighteenth aspect, there is provided a method of enabling retrieval of data from a computer system via a product item, the product item having a printed surface containing human-readable information and machine-readable coded data, the coded data being indicative of an identity of the product item, the method including the steps of:

25 (a) receiving, in the computer system and from a sensing device, indicating data regarding the identity of the product item, the sensing device, when placed in an operative position relative to the product item, generating the indicating data using at least some of the coded data;

30 (b) retrieving, in the computer system and using the indicating data, information relating to the product item; and

(c) outputting, from the computer system and to an output device, the information relating to the product item, the output device selected from the group comprising a display device and a printing device,  
wherein said coded data comprises an ink composition as described above.

5 In a nineteenth aspect, the present invention provides a method of minimizing absorption of visible light in an ink composition comprising an IR-absorbing metal-dithiolene dye, comprising preselecting said dye such that it includes at least one moiety for reducing intermolecular interactions.

10 In a twentieth aspect, the present invention provides a method of minimizing absorption of visible light in an inkjet ink comprising an IR-absorbing metal-dithiolene dye, said method comprising preselecting said dye such that it includes a moiety for reducing intermolecular interactions between adjacent dye molecules.

15 In a twenty first aspect, the present invention provides a method of minimizing visible coloration of a substrate having an IR-absorbing metal-dithiolene dye disposed thereon, said method comprising preselecting said dye such that it includes a moiety for reducing intermolecular interactions between adjacent dye molecules.

20 In a twenty second, there is provided a method of enabling entry of data into a computer system via a printed form, the form containing human-readable information and machine-readable coded data, the coded data being indicative of an identity of the form and of a plurality of reference points of the form, the method including the steps of:

receiving, in the computer system and from a sensing device, indicating data regarding the identity of the form and a position of the sensing device relative to the form, the sensing device, when placed in an operative position relative to the form, generating the indicating data using at least some of the coded data;

25 identifying, in the computer system and from the indicating data, at least one field of the form; and

interpreting, in the computer system, at least some of the indicating data as it relates to the at least one field,

30 wherein said coded data comprises an ink composition in which visible absorption is minimized by a method as described above.

In a twenty third aspect, there is provided a method of enabling entry of data into a computer system via a printed form, the form containing human-readable information and machine-readable coded data, the coded data being indicative of at least one field of the form, the method including the steps of:

5 receiving, in the computer system and from a sensing device, indicating data regarding the at least one field and including movement data regarding movement of the sensing device relative to the form, the sensing device, when moved relative to the form, generating the data regarding said at least one field using at least some of the coded data and generating the data regarding its own movement relative to the form; and

10 interpreting, in the computer system, at least some of said indicating data as it relates to said at least one field,  
wherein said coded data comprises an ink composition in which visible absorption is minimized by a method as described above.

In a twenty fourth aspect, there is provided a method of enabling entry of data into a  
15 computer system via a product item, the product item having a printed surface containing human-readable information and machine-readable coded data, the coded data being indicative of an identity of the product item, the method including the steps of:

(a) receiving, in the computer system and from a sensing device, indicating data regarding  
20 the identity of the product item, the sensing device, when placed in an operative position relative to the product item, generating the indicating data using at least some of the coded data; and

(b) recording, in the computer system and using the indicating data, information relating to  
the product item,  
wherein said coded data comprises an ink composition in which visible absorption is  
25 minimized by a method as described above.

In a twenty fifth aspect, there is provided a method of enabling retrieval of data from a computer system via a product item, the product item having a printed surface containing human-readable information and machine-readable coded data, the coded data being indicative of an identity of the product item, the method including the steps of:

30 (a) receiving, in the computer system and from a sensing device, indicating data regarding the identity of the product item, the sensing device, when placed in an operative position

relative to the product item, generating the indicating data using at least some of the coded data;

(b) retrieving, in the computer system and using the indicating data, information relating to the product item; and

5 (c) outputting, from the computer system and to an output device, the information relating to the product item, the output device selected from the group comprising a display device and a printing device,

wherein said coded data comprises an ink composition in which visible absorption is minimized by a method as described above.

10

#### Brief Description of Drawings

Figure 1 is a schematic of a the relationship between a sample printed netpage and its online page description;

15 Figure 2 is a schematic view of a interaction between a netpage pen, a Web terminal, a netpage printer, a netpage relay, a netpage page server, and a netpage application server, and a Web server;

Figure 3 illustrates a collection of netpage servers, Web terminals, printers and relays interconnected via a network;

20 Figure 4 is a schematic view of a high-level structure of a printed netpage and its online page description;

Figure 5a is a plan view showing the interleaving and rotation of the symbols of four codewords of the tag;

Figure 5b is a plan view showing a macrodot layout for the tag shown in Figure 5a;

25 Figure 5c is a plan view showing an arrangement of nine of the tags shown in Figures 5a and 5b, in which targets are shared between adjacent tags;

Figure 5d is a plan view showing a relationship between a set of the tags shown in Figure 5a and a field of view of a netpage sensing device in the form of a netpage pen;

Figure 6 is a perspective view of a netpage pen and its associated tag-sensing field-of-view cone;

30 Figure 7 is a perspective exploded view of the netpage pen shown in Figure 6;



Figure 8 is a schematic block diagram of a pen controller for the netpage pen shown in Figures 6 and 7;

Figure 9 is a perspective view of a wall-mounted netpage printer;

Figure 10 is a section through the length of the netpage printer of Figure 9;

5 Figure 10a is an enlarged portion of Figure 10 showing a section of the duplexed print engines and glue wheel assembly;

Figure 11 is a detailed view of the ink cartridge, ink, air and glue paths, and print engines of the netpage printer of Figures 9 and 10;

Figure 12 is an exploded view of an ink cartridge;

10 Figure 13 is a schematic view of the structure of an item ID;

Figure 14 is a schematic view of the structure of an omnitag;

Figure 15 is a schematic view of a pen class diagram;

Figure 16 is a schematic view of the interaction between a product item, a fixed product scanner, a hand-held product scanner, a scanner relay, a product server, and a product application server;

Figure 17 is a schematic cross-sectional view through an ink chamber of a unit cell of an inkjet printhead.

Figure 18 shows an absorption spectrum of a dye prepared according to Example 1.

Figure 19 shows an absorption spectrum of a dye prepared according to Example 2.

20 Figure 20 shows an absorption spectrum of a dye prepared according to Example 3.

Figure 21 shows the relative rates of decomposition of a nickel dithiolene, both in the presence of and in the absence of singlet oxygen quenchers.

### Detailed Description

#### 25 IR-Absorbing Dye Disclosure

As used herein, the term "IR-absorbing dye" means a dye substance, which absorbs infrared radiation and which is therefore suitable for detection by an infrared sensor.

Preferably, the IR-absorbing dye absorbs in the near infrared region, and preferably has a  $\lambda_{\max}$  in the range of 700 to 1000 nm, more preferably 750 to 900 nm, more preferably 780 to 850  
30 nm. Dyes having a  $\lambda_{\max}$  in this range are particularly suitable for detection by semiconductor lasers, such as a gallium aluminium arsenide diode laser.

Preferably, the hydrophilic group is selected from a hydrophilic polymer chain; an ammonium group; an acid group including salts thereof; or a sulfonamide group.

An example of a hydrophilic polymeric chain is a PEG chain, which may comprise from 2 to 5000 repeating units of ethylene glycol. Other hydrophilic polymer chains will be readily apparent to the person skilled in the art. The hydrophilic polymer chain may be a substituent (or part of a substituent) on the dye molecule.

An ammonium group may be present as a substituent comprising a group of general formula  $-N^+(R^a)(R^b)(R^c)$  or  $-U$ , wherein  $R^a$ ,  $R^b$ ,  $R^c$  may be the same or different and are independently selected from H,  $C_{1-8}$  alkyl (e.g. methyl, ethyl, cyclohexyl, cyclopentyl, *tert*-butyl, *iso*-propyl etc.),  $C_{6-12}$  arylalkyl (e.g. benzyl, phenylethyl etc.) or  $C_{6-12}$  aryl (e.g. phenyl, naphthyl etc.); and U is pyridinium, imidazolium or pyrrolinium. Alternatively, the ammonium group may be present in the form of a quaternarized N atom in the dye molecule. For example, a heteroaromatic N atom in the dye molecule may be quaternarized with a  $C_{1-8}$  alkyl or a  $C_{6-12}$  arylalkyl group, in accordance with known procedures.

An acid group may be present as a substituent comprising a group of formula  $-CO_2Z$ ,  $-SO_3Z$ ,  $-OSO_3Z$ ,  $-PO_3Z_2$  or  $-OPO_3Z_2$ , wherein Z is H or a water-soluble cation. Preferably, Z is selected from  $Li^+$ ,  $Na^+$  or  $K^+$ . Methods of introducing acid groups, such as those described above, will be well known to the person skilled in the art. For example, a carboxylic acid group may be introduced by oxidation of an olefinic or hydroxyl group in the dye molecule.

Alternatively, a sulfonic acid group ( $-SO_3H$ ) may be introduced to an aromatic moiety in the dye molecule by sulfonation using, for example, oleum or chlorosulfonic acid. Conversion of the acid group to its salt form can be effected using, for example, a metal hydroxide reagent (e.g. LiOH, NaOH or KOH) or a metal bicarbonate (e.g.  $NaHCO_3$ ). Non-metal salts may also be prepared using, for example, an ammonium hydroxide (e.g.  $Bu_4NOH$ ,  $NH_4OH$  etc.).

A sulfonamide group may be present as a substituent comprising a group of general formula  $-SO_2NR^pR^q$ , wherein  $R^p$  and  $R^q$  are independently selected from H,  $C_{1-8}$  alkyl (e.g. methyl, ethyl, cyclohexyl, cyclopentyl, *tert*-butyl, *iso*-propyl etc.),  $C_{6-12}$  arylalkyl (e.g. benzyl, phenylethyl etc.) or  $C_{6-12}$  aryl (e.g. phenyl, naphthyl etc.).

Preferably, at least one of  $R^{10}$ ,  $R^{11}$ ,  $R^{12}$  or  $R^{13}$  comprises a group or moiety for reducing intermolecular interactions. It has been recognized by the present inventors that IR-absorbing

dye compounds of the prior art absorb, at least to some extent, in the visible region of the spectrum. Indeed, the vast majority of IR-absorbing dye compounds known in the prior art are black. This visible absorption is clearly undesirable in "invisible" IR inks, especially IR inks for use in netpage or Hyperlabel™ systems.

5 It has further been recognized by the present inventors that the presence of visible bands in the IR spectra of IR-absorbing dye compounds, and particularly IR-absorbing metal-ligand complexes, is mainly due to intermolecular interactions between adjacent molecules.

Typically, IR-absorbing compounds comprise a  $\pi$ -system which forms a substantially planar moiety in at least part of the molecule. There is a natural tendency for planar  $\pi$ -systems  
10 in adjacent molecules to stack on top of each other *via* intermolecular  $\pi$ -interactions, known as  $\pi$ - $\pi$  stacking. Hence, IR-absorbing compounds have a natural tendency to group together *via* intermolecular  $\pi$ -interactions, producing relatively weakly bound dimers, trimers *etc.* Without wishing to be bound by theory, it is understood by the present inventors that  $\pi$ - $\pi$  stacking of IR-absorbing compounds contributes significantly to the production of visible absorption bands  
15 in their IR spectra, which would not otherwise be present in the corresponding monomeric compounds. This visible absorption is understood to be due to broadening of IR absorption bands when  $\pi$ -systems stack on top of each other and  $\pi$ -orbitals interact, producing small changes in their respective energy levels. Broadening of IR absorption bands is undesirable in two respects: firstly, it reduces the intensity of absorption in the IR region; secondly, the IR  
20 absorption band tends to tail into the visible region, producing highly coloured compounds.

Furthermore, the formation of coloured dimers, trimers *etc.* *via*  $\pi$ - $\pi$  interactions occurs both in the solid state and in solution. However, it is a particular problem in the solid state, where there are no solvent molecules to disrupt the formation of extended  $\pi$ -stacked oligomers. IR dyes having acceptable solution characteristics may still be intensely coloured solids when  
25 printed onto paper. The ideal "invisible" IR dye should remain invisible when the solvent has evaporated or wicked into the paper.

Additionally, the interaction of  $\pi$ -orbitals with local charges or partially charged atoms, such as ions, can be large and this may introduce additional absorption in the visible region.

None of the prior art addresses the problem of visible absorption in IR inks by designing and synthesizing dye molecules specifically adapted to reduce intermolecular interactions in the form of  $\pi$ - $\pi$  stacking.

Specific examples of moieties suitable for reducing intermolecular interactions are described in more detail below. However, it will be appreciated from the above that any moiety or group that can interfere sufficiently with the intermolecular  $\pi$ - $\pi$  interactions of adjacent dye molecules will be suitable for minimizing visible absorption, and will therefore be suitable for use in the present invention.

Generally, it is preferable to configure the dye molecule such that the average distance between the  $\pi$ -systems of adjacent molecules is greater than about 3.5 Å, more preferably greater than about 4 Å, and more preferably greater than about 5 Å. This preferred distance between the  $\pi$ -systems of adjacent molecules is based on theoretical calculations. From theoretical studies by the present inventors, it is understood that  $\pi$ - $\pi$  interactions are significant at a distance of about 3.5 Å or less.

Preferably, the moiety for reducing intermolecular interactions extends out of a major plane of the dye molecule. Metal dithiolenes typically comprise a  $\pi$ -system of a central metal atom, four S atoms and two carbon-carbon double bonds, which form a major plane of the molecule. The moiety for reducing intermolecular interactions is preferably configured, or can at least fold into a conformation, such that it extends out of this plane and exerts steric repulsion on neighbouring dye molecules. The greater the moiety extends out of the plane of the  $\pi$ -system, the greater the reduction in intermolecular interactions will be.

Preferably, the moiety for reducing intermolecular interactions has three-dimensional structure. By "three-dimensional structure", it is meant that the moiety occupies a volume of three-dimensional space in all conformations. Preferably, the moiety is a three-dimensional C<sub>3-30</sub> hydrocarbyl or C<sub>3-30</sub> hydrocarbylene group.

As will be apparent to a person skilled in the art, the exact nature of the three-dimensional hydrocarbyl or hydrocarbylene group is not crucial to the present invention, provided that the group has sufficient three-dimensional structure to inhibit intermolecular interactions. However, preferred moieties suitable for reducing intermolecular interactions are bridged C<sub>4-30</sub> cyclic groups.

As an alternative (or in addition to) the dye molecule comprising a three-dimensional hydrocarbyl or hydrocarbylene group, the molecule may comprise one or more polymeric substituents for reducing intermolecular interactions. In the context of the present invention, the term "polymeric" is used to describe a group having 2 or more repeating monomer units.

5 For example, the polymeric substituent for reducing intermolecular interactions may comprise from 2 to 5000 repeating monomer units, more preferably 2 to 1000, more preferably 2 to 100, and more preferably 2 to 50.

Without wishing to be bound by theory, it is understood by the present inventors that polymeric substituents, especially polymeric substituents positioned at the periphery of the  
10 molecule, interfere with  $\pi$ - $\pi$  interactions by folding into conformations where at least part of the polymer is positioned between  $\pi$ -systems of adjacent dye molecules. This inhibits intermolecular  $\pi$ - $\pi$  interactions and hence polymeric substituents, especially peripheral polymeric substituents, reduce the propensity for  $\pi$ -systems to overlap and interact.

It will be readily apparent that the exact nature of the polymeric substituent(s) is not  
15 crucial provided that it is able to provide steric repulsion. Accordingly, the substituent may comprise any type of polymer, such as polyethers, polyesters, polyamides, polyurethanes, polyalkenes *etc.*

The polymeric group may comprise a plurality of polymer chains in the form of a dendrimer – that is, a central core or template having a plurality of polymer chains radiating  
20 therefrom. The branched nature of dendrimer molecules means that their polymeric chains are able to occupy a large volume in three-dimensional space. This large three-dimensional volume is advantageous for increasing the steric repulsion between respective dye molecules and, hence, reducing intermolecular interactions.

In addition to providing steric repulsion, the polymeric substituent may confer  
25 additional properties on the dye molecule. For example, with appropriate selection of the polymeric substituent, it may be used to impart hydrophilic properties on the molecule. Polymeric substituents comprising repeating units of ethylene glycol (a PEG chain) are particularly suitable for providing hydrophilicity, as well as reducing intermolecular  $\pi$ -interactions.

Preferably,  $R^{10}$  and  $R^{11}$  together are joined to form a bridged cyclic group. Preferably,  $R^{12}$  and  $R^{13}$  together are also joined to form a bridged cyclic group. When the dye molecule has two bridged cyclic ligands, the bridging groups are preferably oriented in opposite directions. This maximizes their steric repulsive effect, since both faces of the molecule are effectively

5 “protected” from adjacent dye molecules.

In a particularly preferred embodiment, the dye is of formula (01II):

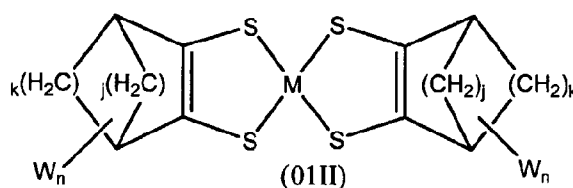

10 wherein:

M is selected from Ni, Pd or Pt (preferably Ni);

j is selected from 0, 1, 2, 3 or 4;

k is selected from 0, 1, 2, 3 or 4;

n is 1, 2 or 3;

15 W is a hydrophilic group;

up to three  $-(CH_2)-$  groups in the carbocycle may be optionally replaced by a group independently selected from  $-C(O)-$ ,  $-NH-$ ,  $-S-$ ,  $-O-$ ;

up to three  $-CH-$  groups in the carbocycle may be optionally replaced by  $-N-$ ;

20 up to four H atoms in the carbocycle may be optionally replaced by a group independently selected from  $C_{1-6}$  alkyl,  $C_{1-6}$  alkoxy,  $C_{6-12}$  aryl,  $C_{6-12}$  arylalkyl, halogen, hydroxyl or amino; and provided that at least one of j or k is greater than 0.

This preferred dye is characterized in that the dithiolene ligands are carbocycles, preferably bridged carbocycles.

25 Preferably, both j and k are greater than or equal to 1. In one preferred form, j is 1 and k is 2. Further, the dye molecule preferably comprises  $-C(Me)_2-$  bridging groups. Preferably, the ligands are bornyl or camphor derivatives. Bornyl or camphor derivatives are advantageous, since they are readily available commercially at relatively low cost.

The group(s) represented by W imparts hydrophilicity to the dye molecule. Preferably, W is selected from a substituent comprising a PEG chain; a substituent comprising an ammonium group; a substituent comprising an acid group, including salts thereof; or a substituent comprising a sulfonamide group. W may be any one of the preferred hydrophilic groups described in detail above. Preferably, W is of formula  $-(CH_2)_t-SO_3Z$ , wherein t is 0 or an integer from 1 to 6, and Z is H or a water-soluble cation. More preferably, W is of formula  $-CH_2SO_3H$ ,  $-CH_2SO_3Na$  or  $-CH_2SO_3K$ .

A particularly preferred dye molecule according to the present invention is shown in formula (III) below:

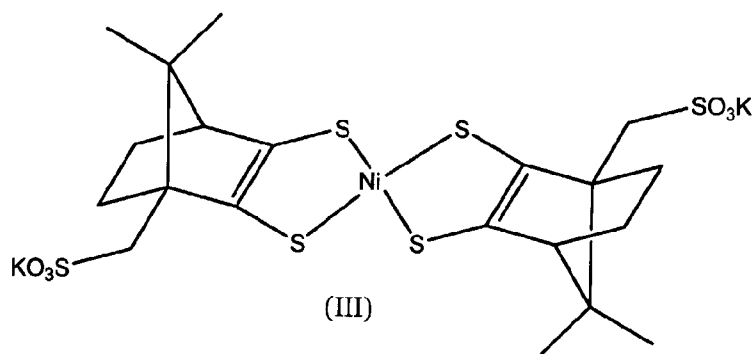

This compound has excellent water-dispersibility combined with minimal absorption in the visible region of the spectrum. It absorbs strongly in the near infrared region at a  $\lambda_{max}$  of 781 nm.

The term "hydrocarbyl" is used herein to refer to monovalent groups consisting generally of carbon and hydrogen. Hydrocarbyl groups thus include alkyl, alkenyl and alkynyl groups (in both straight and branched chain forms), carbocyclic groups (including polycycloalkyl groups such as bicyclooctyl and adamantyl) and aryl groups, and combinations of the foregoing, such as alkylcycloalkyl, alkylpolycycloalkyl, alkylaryl, alkenylaryl, alkynylaryl, cycloalkylaryl and cycloalkenylaryl groups. Similarly, the term "hydrocarbylene" refers to divalent groups corresponding to the monovalent hydrocarbyl groups described above.

Unless specifically stated otherwise, up to four  $-C-C-$  and/or  $-C-H$  moieties in the hydrocarbyl group may be optionally interrupted by one or more moieties selected from  $-O-$ ;  $-NR^w-$ ;  $-S-$ ;  $-C(O)-$ ;  $-C(O)O-$ ;  $-C(O)NR^w-$ ;  $-S(O)-$ ;  $-SO_2-$ ;  $-SO_2O-$ ;  $-SO_2NR^w-$ ; where  $R^w$  is a group selected from H,  $C_{1-12}$  alkyl,  $C_{6-12}$  aryl or  $C_{6-12}$  arylalkyl.

Unless specifically stated otherwise, where the hydrocarbyl group contains one or more  $-C=C-$  moieties, up to four  $-C=C-$  moieties may optionally be replaced by  $-C=N-$ . Hence, the term "hydrocarbyl" may include moieties such as heteroaryl, ether, thioether, carboxy, hydroxyl, alkoxy, amine, thiol, amide, ester, ketone, sulfoxide, sulfonate, sulfonamide *etc.*

5 Unless specifically stated otherwise, the hydrocarbyl group may comprise up to four substituents independently selected from halogen, cyano, nitro, a hydrophilic group as defined above (*e.g.*  $-SO_3H$ ,  $-SO_3K$ ,  $-CO_2Na$ ,  $-NH_3^+$ ,  $-NMe_3^+$  *etc.*) or a polymeric group as defined above (*e.g.* a polymeric group derived from polyethylene glycol).

As used herein, the term "bridged cyclic group" includes  $C_{4-30}$  carbocycles (preferably  
10  $C_{6-20}$  carbocycles) containing 1, 2, 3 or 4 bridging atoms. Examples of bridged carbocyclic groups are bornyl and triptycenylyl, and derivatives thereof. The term "bridged cyclic group" also includes bridged polycyclic groups, including groups such as adamantanylyl and tricyclo[5.2.1.0]decanylyl, and derivatives thereof.

Unless specifically stated otherwise, the term "bridged cyclic group" also includes  
15 bridged carbocycles wherein 1, 2, 3 or 4 carbon atoms are replaced by heteroatoms selected from N, S or O (*i.e.* bridged heterocycles). When it is stated that a carbon atom in a carbocycle is replaced by a heteroatom, what is meant is that  $-CH-$  is replaced by  $-N-$ ,  $-CH_2-$  is replaced by  $-O-$ , or  $-CH_2-$  is replaced by  $-S-$ . Hence, the term "bridged cyclic group" includes bridged heterocyclic groups, such as quinuclidinylyl and tropanylyl. Unless specifically stated  
20 otherwise, any of the bridged cyclic groups may be optionally substituted with 1, 2, 3 or 4 of the substituents described below.

The term "aryl" is used herein to refer to an aromatic group, such as phenyl, naphthyl or triptycenylyl. The term "arylene", of course, refers to divalent groups corresponding to the monovalent aryl groups described above. Any reference to aryl implicitly includes arylene,  
25 where appropriate.

The term "heteroaryl" refers to an aryl group, where 1, 2, 3 or 4 carbon atoms are replaced by a heteroatom selected from N, O or S. Examples of heteroaryl (or heteroaromatic) groups include pyridylyl, benzimidazolyl, indazolyl, quinolinyl, isoquinolinyl, indolinylyl, isoindolinylyl, indolyl, isoindolyl, furanyl, thiophenyl, pyrrolyl, thiazolyl, imidazolyl, oxazolyl,  
30 isoxazolyl, pyrazolyl, isoxazolonylyl, piperazinyl, pyrimidinyl, piperidinyl, morpholinyl,



pyrrolidinyl, isothiazolyl, triazolyl, oxadiazolyl, thiadiazolyl, pyridyl, pyrimidinyl, benzopyrimidinyl, benzotriazole, quinoxaliny, pyridazyl, coumarinyl *etc.* The term “heteroarylene”, of course, refers to divalent groups corresponding to the monovalent heteroaryl groups described above. Any reference to heteroaryl implicitly includes

5 heteroarylene, where appropriate.

Unless specifically stated otherwise, aryl, arylene, heteroaryl and heteroarylene groups may be optionally substituted with 1, 2, 3, 4 or 5 of the substituents described below.

Where reference is made to optionally substituted groups (*e.g.* in connection with bridged cyclic groups, aryl groups or heteroaryl groups), the optional substituent(s) are  
10 independently selected from C<sub>1-8</sub> alkyl, C<sub>1-8</sub> alkoxy, cyano, halogen, amino, hydroxyl, thiol, -SR<sup>v</sup>, -NR<sup>u</sup>R<sup>v</sup>, nitro, phenyl, phenoxy, -CO<sub>2</sub>R<sup>v</sup>, -C(O)R<sup>v</sup>, -OCOR<sup>v</sup>, -SO<sub>2</sub>R<sup>v</sup>, -OSO<sub>2</sub>R<sup>v</sup>, -SO<sub>2</sub>OR<sup>v</sup>, -NHC(O)R<sup>v</sup>, -CONR<sup>u</sup>R<sup>v</sup>, -CONR<sup>u</sup>R<sup>v</sup>, -SO<sub>2</sub>NR<sup>u</sup>R<sup>v</sup>, wherein R<sup>u</sup> and R<sup>v</sup> are independently selected from hydrogen, C<sub>1-12</sub> alkyl, phenyl or phenyl-C<sub>1-8</sub> alkyl (*e.g.* benzyl). Where, for example, a group contains more than one substituent, different substituents can have different  
15 R<sup>u</sup> or R<sup>v</sup> groups. For example, a naphthyl group may be substituted with three substituents: -SO<sub>2</sub>NHPh, -CO<sub>2</sub>Me group and -NH<sub>2</sub>.

The term “alkyl” is used herein to refer to alkyl groups in both straight and branched forms. Unless stated otherwise, the alkyl group may be interrupted with 1, 2 or 3 heteroatoms selected from O, N or S. Unless stated otherwise, the alkyl group may also be interrupted with  
20 1, 2 or 3 double and/or triple bonds. However, the term “alkyl” usually refers to alkyl groups having no heteroatom interruptions or double or triple bond interruptions. Where “alkenyl” groups are specifically mentioned, this is not intended to be construed as a limitation on the definition of “alkyl” above.

Where reference is made to, for example, C<sub>1-12</sub> alkyl, it is meant the alkyl group may  
25 contain any number of carbon atoms between 1 and 12. Unless specifically stated otherwise, any reference to “alkyl” means C<sub>1-12</sub> alkyl, preferably C<sub>1-6</sub> alkyl.

The term “alkyl” also includes cycloalkyl groups. As used herein, the term “cycloalkyl” includes cycloalkyl, polycycloalkyl, and cycloalkenyl groups, as well as combinations of these with linear alkyl groups, such as cycloalkylalkyl groups. The cycloalkyl group may be  
30 interrupted with 1, 2 or 3 heteroatoms selected from O, N or S. However, the term “cycloalkyl” usually refers to cycloalkyl groups having no heteroatom interruptions. Examples of cycloalkyl

groups include cyclopentyl, cyclohexyl, cyclohexenyl, cyclohexylmethyl and adamantyl groups.

The term "arylalkyl" refers to groups such as benzyl, phenylethyl and naphthylmethyl.

The term "halogen" or "halo" is used herein to refer to any of fluorine, chlorine,  
5 bromine and iodine. Usually, however, halogen refers to chlorine or fluorine substituents.

Where reference is made to "a substituent comprising ..." (e.g. "a substituent comprising a hydrophilic group", "a substituent comprising an acid group (including salts thereof)", "a substituent comprising a polymeric chain" *etc.*), the substituent in question may consist entirely or partially of the group specified. For example, "a substituent comprising an  
10 acid group (including salts thereof)" may be of formula  $-(CH_2)_j-SO_3K$ , wherein  $j$  is 0 or an integer from 1 to 6. Hence, in this context, the term "substituent" may be, for example, an alkyl group, which has a specified group attached. However, it will be readily appreciated that the exact nature of the substituent is not crucial to the desired functionality, provided that the specified group is present.

15 Chiral compounds described herein have not been given stereo-descriptors. However, when compounds may exist in stereoisomeric forms, then all possible stereoisomers and mixtures thereof are included (e.g. enantiomers, diastereomers and all combinations including racemic mixtures *etc.*).

Likewise, when compounds may exist in a number of regioisomeric forms, then all  
20 possible regioisomers and mixtures thereof are included.

For the avoidance of doubt, the term "a" (or "an"), in phrases such as "comprising a", means "at least one" and not "one and only one". Where the term "at least one" is specifically used, this should not be construed as having a limitation on the definition of "a".

Throughout the specification, the term "comprising", or variations such as "comprise"  
25 or "comprises", should be construed as including a stated element, integer or step, but not excluding any other element, integer or step.

#### *Ink Compositions Comprising Singlet Oxygen Quencher Disclosure*

As used herein, the term "IR-absorbing dye" means a dye substance, which absorbs  
30 infrared radiation and which is therefore suitable for detection by an infrared sensor.

Preferably, the IR-absorbing dye absorbs in the near infrared region, and preferably has a  $\lambda_{max}$

in the range of 700 to 1000 nm, more preferably 750 to 900 nm, more preferably 780 to 850 nm. Dyes having a  $\lambda_{\max}$  in this range are particularly suitable for detection by semiconductor lasers, such as a gallium aluminium arsenide diode laser.

As used herein, the term "metal-dithiolene" means any complex comprising a metal  
5 (usually Ni, Pd or Pt) and at least one dithiolene ligand. Dithiolene ligands are generally characterized in having a  $-(SCR^{L1}=CR^{L2}S)-$  motif, where the two S atoms are bonded to the central atom, and L1 and L2 are hydrocarbyl groups, which form the remainder of the ligand.

Metal-dithiolenes are excellent candidates for IR inks. They show strong absorption in the near-IR region and, in some cases, minimal absorption in the visible region. However, a  
10 major shortcoming of metal-dithiolene dyes is their instability when printed onto a substrate, such as paper. Metal-dithiolenes are particularly unstable towards u.v. light, which is observable as poor lightfastness in printed documents.

Without wishing to be bound by theory, it is understood by the present inventors that the poor stability of the metal-dithiolenes is due to their ability to excite atmospheric triplet  
15 oxygen to its singlet state. It is understood to be an unfortunate coincidence that the energy required to excite atmospheric triplet oxygen to singlet oxygen matches the energy released when a metal-dithiolene molecule relaxes from its excited state after absorption of a photon. Hence, it is believed that metal-dithiolenes promote production of singlet oxygen.

Singlet oxygen is a highly reactive species, which attacks many different types of  
20 organic compounds. It is known to attack C-H and C=C bonds and, in the case of metal-dithiolenes, oxidation of sulfur is also highly likely. Hence, the production of singlet oxidation provides a mechanism for degradation of metal-dithiolenes and, with it, the loss of their IR-absorbing properties.

In the present invention, the presence of singlet oxygen quencher(s) in the ink  
25 composition reduces the propensity for metal-dithiolenes to degrade. The quencher consumes any singlet oxygen generated in the vicinity of the dye molecules and, hence, minimizes their degradation. An excess of singlet oxygen quencher is advantageous for minimizing degradation of the metal-dithiolene dye and retaining its IR-absorbing properties over time.

Preferably, the singlet oxygen quencher is selected from ascorbic acid, 1,4-  
30 diazabicyclo-[2.2.2]octane (DABCO), azides (*e.g.* sodium azide), histidine or tryptophan. More preferably, the singlet oxygen quencher is ascorbic acid or sodium azide.

Preferably, the ink composition comprises a metal-dithiolene dye of formula (02I):

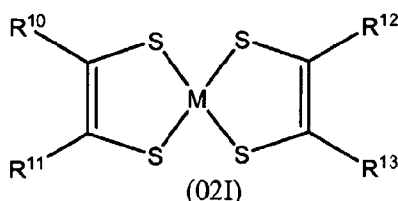

wherein:

M is selected from Ni, Pd or Pt (preferably Ni);

- 5  $R^{10}$  and  $R^{11}$  are independently selected from  $C_{1-30}$  hydrocarbyl, or  $R^{10}$  and  $R^{11}$  together are joined to form a  $C_{2-30}$  hydrocarbylene group; and  
 $R^{12}$  and  $R^{13}$  are independently selected from  $C_{1-30}$  hydrocarbyl, or  $R^{12}$  and  $R^{13}$  together are joined to form a  $C_{2-30}$  hydrocarbylene group.

10 Preferably, at least one of  $R^{10}$ ,  $R^{11}$ ,  $R^{12}$  or  $R^{13}$  comprises a hydrophilic group. The hydrophilic group may be selected from a hydrophilic polymer chain; an ammonium group; an acid group including salts thereof; or a sulfonamide group.

15 An example of a hydrophilic polymeric chain is a PEG chain, which may comprise from 2 to 5000 repeating units of ethylene glycol. Other hydrophilic polymer chains will be readily apparent to the person skilled in the art. The hydrophilic polymer chain may be a substituent (or part of a substituent) on the dye molecule.

20 An ammonium group may be present as a substituent comprising a group of general formula  $-N^+(R^a)(R^b)(R^c)$  or  $-U$ , wherein  $R^a$ ,  $R^b$ ,  $R^c$  may be the same or different and are independently selected from H,  $C_{1-8}$  alkyl (*e.g.* methyl, ethyl, cyclohexyl, cyclopentyl, *tert*-butyl, *iso*-propyl *etc.*),  $C_{6-12}$  arylalkyl (*e.g.* benzyl, phenylethyl *etc.*) or  $C_{6-12}$  aryl (*e.g.* phenyl, naphthyl *etc.*); and U is pyridinium, imidazolium or pyrrolinium. Alternatively, the ammonium group may be present in the form of a quaternarized N atom in the dye molecule. For example, a heteroaromatic N atom in the dye molecule may be quaternarized with a  $C_{1-8}$  alkyl or a  $C_{6-12}$  arylalkyl group, in accordance with known procedures.

25 An acid group may be present as a substituent comprising a group of formula  $-CO_2Z$ ,  $-SO_3Z$ ,  $-OSO_3Z$ ,  $-PO_3Z_2$  or  $-OPO_3Z_2$ , wherein Z is H or a water-soluble cation. Preferably, Z is selected from  $Li^+$ ,  $Na^+$  or  $K^+$ . Methods of introducing acid groups, such as those described above, will be well known to the person skilled in the art. For example, a carboxylic acid group

may be introduced by oxidation of an olefinic or hydroxyl group in the dye molecule. Alternatively, a sulfonic acid group ( $-\text{SO}_3\text{H}$ ) may be introduced to an aromatic moiety in the dye molecule by sulfonation using, for example, oleum or chlorosulfonic acid. Conversion of the acid group to its salt form can be effected using, for example, a metal hydroxide reagent (e.g. LiOH, NaOH or KOH) or a metal bicarbonate (e.g.  $\text{NaHCO}_3$ ). Non-metal salts may also be prepared using, for example, an ammonium hydroxide (e.g.  $\text{Bu}_4\text{NOH}$ ,  $\text{NH}_4\text{OH}$  etc.).

A sulfonamide group may be present as a substituent comprising a group of general formula  $-\text{SO}_2\text{NR}^p\text{R}^q$ , wherein  $\text{R}^p$  and  $\text{R}^q$  are independently selected from H,  $\text{C}_{1-8}$  alkyl (e.g. methyl, ethyl, cyclohexyl, cyclopentyl, *tert*-butyl, *iso*-propyl etc.),  $\text{C}_{6-12}$  arylalkyl (e.g. benzyl, phenylethyl etc.) or  $\text{C}_{6-12}$  aryl (e.g. phenyl, naphthyl etc.).

Preferably, at least one of  $\text{R}^{10}$ ,  $\text{R}^{11}$ ,  $\text{R}^{12}$  or  $\text{R}^{13}$  comprises a group or moiety for reducing cofacial interactions.

It has been recognized by the present inventors that IR-absorbing dye compounds of the prior art absorb, at least to some extent, in the visible region of the spectrum. Indeed, the vast majority of IR-absorbing dye compounds known in the prior art are black. This visible absorption is clearly undesirable in "invisible" IR inks, especially IR inks for use in netpage or Hyperlabel™ systems.

It has further been recognized by the present inventors that the presence of visible bands in the IR spectra of IR-absorbing dye compounds, and particularly IR-absorbing metal-ligand complexes, is mainly due to cofacial interactions between adjacent molecules.

Typically, IR-absorbing compounds comprise a  $\pi$ -system which forms a substantially planar moiety in at least part of the molecule. There is a natural tendency for planar  $\pi$ -systems in adjacent molecules to stack on top of each other *via* cofacial  $\pi$ -interactions, known as  $\pi$ - $\pi$  stacking. Hence, IR-absorbing compounds have a natural tendency to group together *via* cofacial  $\pi$ -interactions, producing relatively weakly bound dimers, trimers etc. Without wishing to be bound by theory, it is understood by the present inventors that  $\pi$ - $\pi$  stacking of IR-absorbing compounds contributes significantly to the production of visible absorption bands in their IR spectra, which would not otherwise be present in the corresponding monomeric compounds. This visible absorption is understood to be due to broadening of IR absorption bands when  $\pi$ -systems stack on top of each other and  $\pi$ -orbitals interact, producing small

changes in their respective energy levels. Broadening of IR absorption bands is undesirable in two respects: firstly, it reduces the intensity of absorption in the IR region; secondly, the IR absorption band tends to tail into the visible region, producing highly coloured compounds.

Furthermore, the formation of coloured dimers, trimers *etc. via*  $\pi$ - $\pi$  interactions occurs both in the solid state and in solution. However, it is a particular problem in the solid state, where there are no solvent molecules to disrupt the formation of extended  $\pi$ -stacked oligomers. IR dyes having acceptable solution characteristics may still be intensely coloured solids when printed onto paper. The ideal "invisible" IR dye should remain invisible when the solvent has evaporated or wicked into the paper.

Additionally, the interaction of  $\pi$ -orbitals with local charges or partially charged atoms, such as ions, can be large and this may introduce additional absorption in the visible region.

None of the prior art addresses the problem of visible absorption in IR inks by designing and synthesizing dye molecules specifically adapted to reduce cofacial interactions in the form of  $\pi$ - $\pi$  stacking.

Specific examples of moieties suitable for reducing cofacial interactions are described in more detail below. However, it will be appreciated from the above that any moiety or group that can interfere sufficiently with the cofacial  $\pi$ - $\pi$  interactions of adjacent dye molecules will be suitable for minimizing visible absorption, and will therefore be suitable for use in the present invention.

Generally, it is preferable to configure the dye molecule such that the average distance between the  $\pi$ -systems of adjacent molecules is greater than about 3.5 Å, more preferably greater than about 4 Å, and more preferably greater than about 5 Å. This preferred distance between the  $\pi$ -systems of adjacent molecules is based on theoretical calculations. From theoretical studies by the present inventors, it is understood that  $\pi$ - $\pi$  interactions are significant at a distance of about 3.5 Å or less.

Preferably, the moiety for reducing cofacial interactions extends out of a major plane of the dye molecule. Metal dithiolene dyes typically comprise a  $\pi$ -system of a central metal atom, four S atoms and two carbon-carbon double bonds, which forms a major plane of the molecule. The moiety for reducing cofacial interactions is preferably configured, or can at least fold into a conformation, such that it extends out of this plane and exert steric repulsion on neighbouring

dye molecules. The greater the moiety extends out of the plane of the  $\pi$ -system, the greater the reduction in cofacial interactions will be.

Preferably, the moiety for reducing cofacial interactions has three-dimensional structure. By "three-dimensional structure", it is meant that the moiety occupies a volume of three-dimensional space in all conformations. Preferably, the moiety is a three-dimensional C<sub>3-30</sub> hydrocarbyl or C<sub>3-30</sub> hydrocarbylene group.

As will be apparent to a person skilled in the art, the exact nature of the three-dimensional hydrocarbyl or hydrocarbylene group is not crucial to the present invention, provided that the group has sufficient three-dimensional structure to inhibit cofacial interactions. However, preferred moieties suitable for reducing cofacial interactions are bridged C<sub>3-30</sub> cyclic groups.

As an alternative (or in addition to) the dye molecule comprising a three-dimensional hydrocarbyl or hydrocarbylene group, the molecule may comprise one or more polymeric substituents for reducing cofacial interactions. In the context of the present invention, the term "polymeric" is used to describe a group having 2 or more repeating monomer units. For example, the polymeric substituent for reducing cofacial interactions may comprise from 2 to 5000 repeating monomer units, more preferably 2 to 1000, more preferably 2 to 100, and more preferably 2 to 50.

Without wishing to be bound by theory, it is understood by the present inventors that polymeric substituents, especially polymeric substituents positioned at the periphery of the molecule, interfere with  $\pi$ - $\pi$  interactions by folding into conformations where at least part of the polymer is positioned between  $\pi$ -systems of adjacent dye molecules. This inhibits cofacial  $\pi$ - $\pi$  interactions and hence polymeric substituents, especially peripheral polymeric substituents, reduce the propensity for  $\pi$ -systems to overlap and interact.

It will be readily apparent that the exact nature of the polymeric substituent(s) is not crucial provided that it is able to provide steric repulsion. Accordingly, the substituent may comprise any type of polymer, such as polyethers, polyesters, polyamides, polyurethanes, polyalkenes *etc.*

The polymeric group may comprise a plurality of polymer chains in the form of a dendrimer – that is, a central core or template having a plurality of polymer chains radiating

therefrom. The branched nature of dendrimer molecules means that their polymeric chains are able to occupy a large volume in three-dimensional space. This large three-dimensional volume is advantageous for increasing the steric repulsion between respective dye molecules and, hence, reducing cofacial interactions.

5 In addition to providing steric repulsion, the polymeric substituent may confer additional properties on the dye molecule. For example, with appropriate selection of the polymeric substituent, it may be used to impart hydrophilic properties on the molecule. Polymeric substituents comprising repeating units of ethylene glycol (a PEG chain) are particularly suitable for providing hydrophilicity, as well as reducing cofacial  $\pi$ -interactions.

10 Preferably,  $R^{10}$  and  $R^{11}$  together are joined to form a cyclic group, more preferably a bridged cyclic group. Preferably,  $R^{12}$  and  $R^{13}$  together are also joined to form a cyclic group, more preferably a bridged cyclic group. When the dye molecule has two bridged cyclic ligands, the bridging groups are preferably oriented in opposite directions. This maximizes their steric repulsive effect, since both faces of the molecule are effectively "protected" from adjacent dye molecules.

15 In a particularly preferred embodiment, the ink composition of the present invention comprises a dye of formula (02II):

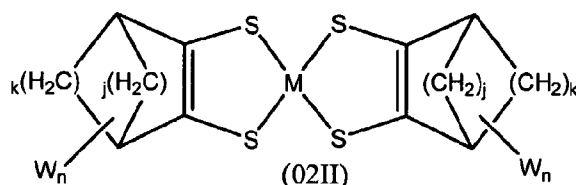

20

wherein:

M is selected from Ni, Pd or Pt (preferably Ni);

j is selected from 0, 1, 2, 3 or 4;

k is selected from 0, 1, 2, 3 or 4;

25 n is 0, 1, 2 or 3;

W is a hydrophilic group;



up to three  $-(CH_2)-$  groups in the carbocycle may be optionally replaced by a group independently selected from  $-C(O)-$ ,  $-NH-$ ,  $-S-$ ,  $-O-$ ;

up to three  $-CH-$  groups in the carbocycle may be optionally replaced by  $-N-$ ;

up to four H atoms in the carbocycle may be optionally replaced by a group independently selected from  $C_{1-6}$  alkyl,  $C_{1-6}$  alkoxy,  $C_{5-12}$  aryl,  $C_{5-12}$  arylalkyl, halogen, hydroxyl or amino; and provided that at least one of j or k is greater than 0.

Preferred dyes according to formula (II) are characterized in that the dithiolene ligands are carbocycles, preferably bridged carbocycles.

Preferably, both j and k are greater than or equal to 1. In one preferred form, j is 1 and k is 2. Further, the dye molecule preferably comprises  $-C(Me)_2-$  bridging groups. Preferably, the ligands are bornene or camphor derivatives. Bornene or camphor derivatives are advantageous, since they are readily available commercially at relatively low cost.

The group(s) represented by W imparts hydrophilicity to the dye molecule. Preferably, W is selected from a substituent comprising a PEG chain; a substituent comprising an ammonium group; a substituent comprising an acid group, including salts thereof; or a substituent comprising a sulfonamide group. W may comprise any one of the preferred hydrophilic groups described above. Preferably, W is of formula  $-(CH_2)_t-SO_3Z$ , wherein t is 0 or an integer from 1 to 6, and Z is H or a water-soluble cation. More preferably, W is of formula  $-CH_2SO_3H$ ,  $-CH_2SO_3Na$  or  $-CH_2SO_3K$ .

A particularly preferred dye molecule for use in the present invention is shown in formula (III) below:

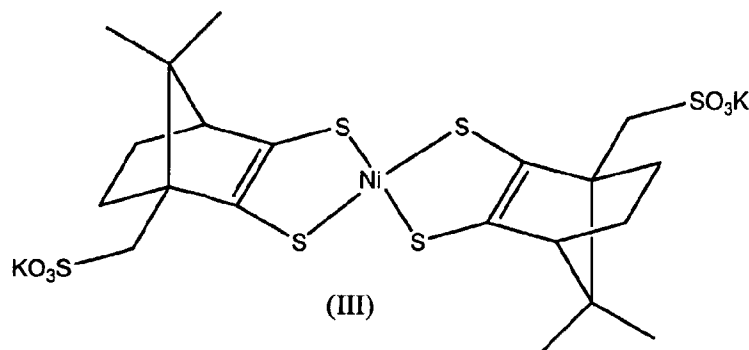

This compound has excellent water-dispersibility combined with minimal absorption in the visible region of the spectrum. It absorbs strongly in the near infrared region at a  $\lambda_{\max}$  of 781 nm.

#### 5 Method of Minimizing Visible Absorption Disclosure

As used herein, the term "IR-absorbing dye" means a dye substance, which absorbs infrared radiation and which is therefore suitable for detection by an infrared sensor. Preferably, the IR-absorbing dye absorbs in the near infrared region, and preferably has a  $\lambda_{\max}$  in the range of 700 to 1000 nm, more preferably 750 to 900 nm, more preferably 780 to 850  
10 nm. Dyes having a  $\lambda_{\max}$  in this range are particularly suitable for detection by semiconductor lasers, such as a gallium aluminium arsenide diode laser.

As used herein, the term "metal-dithiolene" means any complex comprising a metal (usually Ni, Pd or Pt) and at least one dithiolene ligand. Dithiolene ligands are generally characterized in having a  $-(SCR^{L1}=CR^{L2}S)-$  motif, where the two S atoms are bonded to the  
15 central atom, and L1 and L2 are hydrocarbyl groups, which form the remainder of the ligand.

It has been recognized by the present inventors that IR-absorbing dye compounds of the prior art absorb, at least to some extent, in the visible region of the spectrum. Indeed, the vast majority of IR-absorbing dye compounds known in the prior art are black. This visible absorption is clearly undesirable in "invisible" IR inks, especially IR inks for use in netpage or  
20 Hyperlabel™ systems.

It has further been recognized by the present inventors that the presence of visible bands in the IR spectra of IR-absorbing dye compounds, and particularly IR-absorbing metal-ligand complexes, is mainly due to intermolecular interactions between adjacent molecules.

Typically, IR-absorbing compounds comprise a  $\pi$ -system which forms a substantially  
25 planar moiety in at least part of the molecule. There is a natural tendency for planar  $\pi$ -systems in adjacent molecules to stack on top of each other *via* intermolecular  $\pi$ -interactions, known as  $\pi$ - $\pi$  stacking. Hence, IR-absorbing compounds have a natural tendency to group together *via* intermolecular  $\pi$ -interactions, producing relatively weakly bound dimers, trimers *etc.* Without wishing to be bound by theory, it is understood by the present inventors that  $\pi$ - $\pi$  stacking of  
30 IR-absorbing compounds contributes significantly to the production of visible absorption bands

in their IR spectra, which would not otherwise be present in the corresponding monomeric compounds. This visible absorption is understood to be due to broadening of IR absorption bands when  $\pi$ -systems stack on top of each other and  $\pi$ -orbitals interact, producing small changes in their respective energy levels. Broadening of IR absorption bands is undesirable in two respects: firstly, it reduces the intensity of absorption in the IR region; secondly, the IR absorption band tends to tail into the visible region, producing highly coloured compounds.

Furthermore, the formation of coloured dimers, trimers *etc. via*  $\pi$ - $\pi$  interactions occurs both in the solid state and in solution. However, it is a particular problem in the solid state, where there are no solvent molecules to disrupt the formation of extended  $\pi$ -stacked oligomers. IR dyes having acceptable solution characteristics may still be intensely coloured solids when printed onto paper. The ideal "invisible" IR dye should remain invisible when the solvent has evaporated or wicked into the paper.

Additionally, the interaction of  $\pi$ -orbitals with local charges or partially charged atoms, such as ions, can be large and this may introduce additional absorption in the visible region.

None of the prior art addresses the problem visible absorption in IR inks by designing and synthesizing dye molecules specifically adapted to reduce intermolecular interactions in the form of  $\pi$ - $\pi$  stacking.

Specific examples of moieties suitable for reducing intermolecular interactions are described in more detail below. However, it will be appreciated from the above that any moiety or group that can interfere sufficiently with the intermolecular  $\pi$ - $\pi$  interactions of adjacent dye molecules will be suitable for minimizing visible absorption, and will therefore be suitable for use in the present invention.

Preferably, the moiety configured to reduce intermolecular interactions reduces these interactions by a steric repulsive effect. Hence, by providing a dye molecule having suitably positioned sterically repulsive group(s), it is possible to increase the distance between potentially interacting  $\pi$ -systems, thereby minimizing  $\pi$ - $\pi$  stacking.

Preferably, the moiety configured to reduce intermolecular interactions is positioned at the periphery of the dye molecule, or at least at the periphery of the substantially planar  $\pi$ -system. Typically, intermolecular  $\pi$ -interactions result from overlapping planes of  $\pi$ -systems.

By positioning the moiety at the periphery of the dye molecule, the moiety has a maximum effect in reducing the degree of overlap.

Generally, it is preferable to configure the dye molecule such that the average distance between the  $\pi$ -systems of adjacent molecules is greater than about 3.5 Å, more preferably greater than about 4 Å, and more preferably greater than about 5 Å. This preferred distance between the  $\pi$ -systems of adjacent molecules is based on theoretical calculations. From theoretical studies by the present inventors, it is understood that  $\pi$ - $\pi$  interactions are significant at a distance of 3.5 Å or less.

Preferably, the moiety for reducing intermolecular interactions extends out of the plane of the substantially planar  $\pi$ -system. Metal-dithiolenes (e.g. nickel dithiolenes) typically have a substantially planar  $\pi$ -system defined by a central nickel atom, two pairs of sulfur atoms and a pair of double bonds to which the sulfur atoms are vicinally bonded. The moiety is preferably configured, or can at least fold into a conformation, such that it extends out of this plane and exert steric repulsion on neighbouring dye molecules. The greater the moiety extends out of the plane of the  $\pi$ -system, the greater the reduction in intermolecular interactions will be.

Preferably, the moiety for reducing intermolecular interactions has three-dimensional structure. By "three-dimensional structure", it is meant that the moiety occupies a volume of three-dimensional space in all conformations. Preferably, the moiety is a three-dimensional C<sub>3-30</sub> hydrocarbyl or C<sub>3-30</sub> hydrocarbylene group.

As will be apparent to the person skilled in the art, the exact nature of the three-dimensional hydrocarbyl or hydrocarbylene group is not crucial to the present invention, provided that the group has sufficient three-dimensional structure to inhibit intermolecular interactions. However, preferred moieties suitable for reducing intermolecular interactions are C<sub>3-30</sub> bridged cyclic groups. As mentioned above, such groups are preferably positioned at the periphery of the  $\pi$ -system to maximize their overlap-inhibiting effect.

As an alternative (or in addition to) the dye molecule comprising a three-dimensional hydrocarbyl or hydrocarbylene group, such as a bridged cyclic group, it may comprise one or more polymeric substituents for reducing intermolecular interactions. In the context of the present invention, the term "polymeric" is used to describe a group having 2 or more repeating monomer units. For example, the polymeric substituent for reducing intermolecular

interactions may comprise from 2 to 5000 repeating monomer units, more preferably 2 to 1000, more preferably 2 to 100, and more preferably 2 to 50.

Without wishing to be bound by theory, it is understood by the present inventors that polymeric substituents interfere with  $\pi$ - $\pi$  interactions by folding into conformations where at least part of the polymer is positioned between  $\pi$ -systems of adjacent dye molecules. This inhibits intermolecular  $\pi$ - $\pi$  interactions and hence polymeric substituents can reduce the propensity for  $\pi$ -systems to overlap and interact.

It will be readily apparent that the exact nature of the polymeric substituent(s) is not crucial provided that it is able to provide steric repulsion. Accordingly, the substituent may comprise any type of polymer, such as polyethers, polyesters, polyamides, polyurethanes, polyalkenes *etc.*

The polymeric group may comprise a plurality of polymer chains in the form of a dendrimer – that is, a central core or template having a plurality of polymer chains radiating therefrom. The branched nature of dendrimer molecules means that their polymeric chains are able to occupy a large volume in three-dimensional space. This large three-dimensional volume is advantageous for increasing the steric repulsion between respective dye molecules and, hence, reducing intermolecular interactions.

In addition to providing steric repulsion, the polymeric substituent may confer additional properties on the dye molecule. For example, with appropriate selection of the polymeric substituent, it may be used to impart hydrophilic properties on the molecule. Polymeric substituents comprising repeating units of ethylene glycol (a PEG chain) are particularly suitable for providing hydrophilicity, as well as reducing intermolecular  $\pi$ -interactions.

Preferably, the dye molecule comprises a hydrophilic group. A hydrophilic group is preferred for imparting water-dispersibility or water-solubility on the dye molecule. The dye molecules of the present invention are intended for use in inkjet ink compositions, preferably aqueous inkjet ink compositions. Hence, the provision of a hydrophilic group is one means for allowing the dye molecules of the present invention to be dispersed in an aqueous inkjet ink composition.

Preferably, the hydrophilic group is selected from a hydrophilic polymer chain; an ammonium group; an acid group including salts thereof; or a sulfonamide group.

An example of a hydrophilic polymeric chain is a PEG chain, which may comprise from 2 to 5000 repeating units of ethylene glycol. Other hydrophilic polymer chains will be readily apparent to the person skilled in the art. The hydrophilic polymer chain may be a substituent (or part of a substituent) on the dye molecule.

An ammonium group may be present as a substituent comprising a group of general formula  $-N^+(R^a)(R^b)(R^c)$  or  $-U$ , wherein  $R^a$ ,  $R^b$ ,  $R^c$  may be the same or different and are independently selected from H,  $C_{1-8}$  alkyl (e.g. methyl, ethyl, cyclohexyl, cyclopentyl, *tert*-butyl, *iso*-propyl etc.),  $C_{6-12}$  arylalkyl (e.g. benzyl, phenylethyl etc.) or  $C_{6-12}$  aryl (e.g. phenyl, naphthyl etc.); and U is pyridinium, imidazolium or pyrrolinium. Alternatively, the ammonium group may be present in the form of a quaternarized N atom in the dye molecule. For example, a heteroaromatic N atom in the dye molecule may be quaternarized with a  $C_{1-8}$  alkyl or a  $C_{6-12}$  arylalkyl group, in accordance with known procedures.

An acid group may be present as a substituent comprising a group of formula  $-CO_2Z$ ,  $-SO_3Z$ ,  $-OSO_3Z$ ,  $-PO_3Z_2$  or  $-OPO_3Z_2$ , wherein Z is H or a water-soluble cation. Preferably, Z is selected from  $Li^+$ ,  $Na^+$  or  $K^+$ . Methods of introducing acid groups, such as those described above, will be well known to the person skilled in the art. For example, a carboxylic acid group may be introduced by oxidation of an olefinic or hydroxyl group in the dye molecule. Alternatively, a sulfonic acid group ( $-SO_3H$ ) may be introduced to an aromatic moiety in the dye molecule by sulfonation using, for example, oleum or chlorosulfonic acid. Conversion of the acid group to its salt form can be effected using, for example, a metal hydroxide reagent (e.g. LiOH, NaOH or KOH) or a metal bicarbonate (e.g.  $NaHCO_3$ ). Non-metal salts may also be prepared using, for example, an ammonium hydroxide (e.g.  $Bu_4NOH$ ,  $NH_4OH$  etc.).

A sulfonamide group may be present as a substituent comprising a group of general formula  $-SO_2NR^pR^q$ , wherein  $R^p$  and  $R^q$  are independently selected from H,  $C_{1-8}$  alkyl (e.g. methyl, ethyl, cyclohexyl, cyclopentyl, *tert*-butyl, *iso*-propyl etc.),  $C_{6-12}$  arylalkyl (e.g. benzyl, phenylethyl etc.) or  $C_{6-12}$  aryl (e.g. phenyl, naphthyl etc.).

In a preferred method of the present invention, the dye is preselected from a metal-dithiolene of formula (03I):

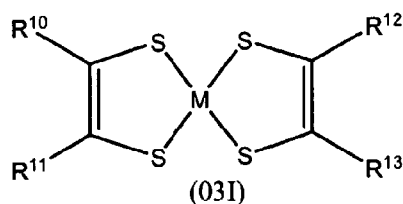

wherein:

M is selected from Ni, Pd or Pt;

$R^{10}$  and  $R^{11}$  are independently selected from  $C_{1-30}$  hydrocarbyl, or  $R^{10}$  and  $R^{11}$  together are  
5 joined to form a  $C_{1-30}$  hydrocarbylene group;

$R^{12}$  and  $R^{13}$  are independently selected from  $C_{1-30}$  hydrocarbyl, or  $R^{12}$  and  $R^{13}$  together are  
joined to form a  $C_{1-30}$  hydrocarbylene group;

wherein at least one of  $R^{10}$ ,  $R^{11}$ ,  $R^{12}$  or  $R^{13}$  comprises a moiety for reducing intermolecular  
interactions.

10 The moiety for reducing intermolecular may be any of the moieties described above. In  
a preferred form, at least one of  $R^{10}$ ,  $R^{11}$ ,  $R^{12}$  or  $R^{13}$  comprises a bridged cyclic group. More  
preferably,  $R^{10}/R^{11}$  and  $R^{12}/R^{13}$  are joined to form bridged cyclic groups. When the dye  
molecule has two bridged cyclic ligands, the bridging groups are preferably oriented in  
opposite directions. This maximizes their steric repulsive effect, since both faces of the  
15 molecule are effectively "protected" from adjacent dye molecules.

Alternatively (or in addition), at least one of  $R^{10}$ ,  $R^{11}$ ,  $R^{12}$  or  $R^{13}$  may comprise a  
polymer, such as a dendrimer or a group comprising a PEG chain.

Preferably, the dye of formula (I) additionally comprises a hydrophilic group. The  
hydrophilic group may be any of the hydrophilic groups described above.

20 In a particularly method of the present invention, the dye is preselected from a metal-  
dithiolene of formula (03II):

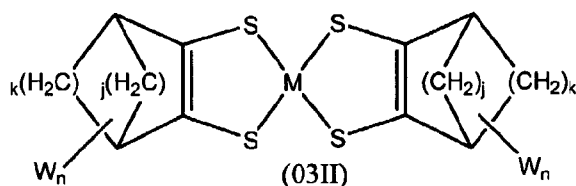

wherein:

M is selected from Ni, Pd or Pt (preferably Ni);

j is selected from 1, 2, 3 or 4;

k is selected from 1, 2, 3 or 4;

5 n is 0, 1, 2 or 3;

W is a hydrophilic group;

up to three  $-(CH_2)-$  groups in the carbocycle may be optionally replaced by a group independently selected from  $-C(O)-$ ,  $-NH-$ ,  $-S-$ ,  $-O-$ ;

up to three  $-CH-$  groups in the carbocycle may be optionally replaced by  $-N-$ ; and

10 up to four H atoms in the carbocycle may be optionally replaced a group independently selected from  $C_{1-6}$  alkyl,  $C_{1-6}$  alkoxy,  $C_{5-12}$  aryl,  $C_{5-12}$  arylalkyl, halogen, hydroxyl or amino.

This preferred dye is characterized in that the dithiolene ligands are bridged cyclic groups, preferably bridged carbocycles.

In one preferred form, j is 1 and k is 2. Further, the dye molecule preferably comprises  
15  $-C(Me)_2-$  bridging groups. In other words, the ligands are preferably bornene derivatives. Bornene derivatives are advantageous, since they are readily available commercially at relatively low cost.

The group(s) represented by W imparts hydrophilicity to the dye molecule. Preferably, W is selected from a substituent comprising a PEG chain; a substituent comprising an  
20 ammonium group; a substituent comprising an acid group, including salts thereof; or a substituent comprising a sulfonamide group. W may be any one of the preferred hydrophilic groups described above. Preferably, W is of formula  $-(CH_2)_t-SO_3Z$ , wherein t is 0 or an integer from 1 to 6, and Z is H or a water-soluble cation. More preferably, W is of formula  $-CH_2SO_3H$ ,  $-CH_2SO_3Na$  or  $-CH_2SO_3K$ .

25 A particularly preferred metal-dithiolene dye for use in the method of the present invention is shown in formula (III) below:



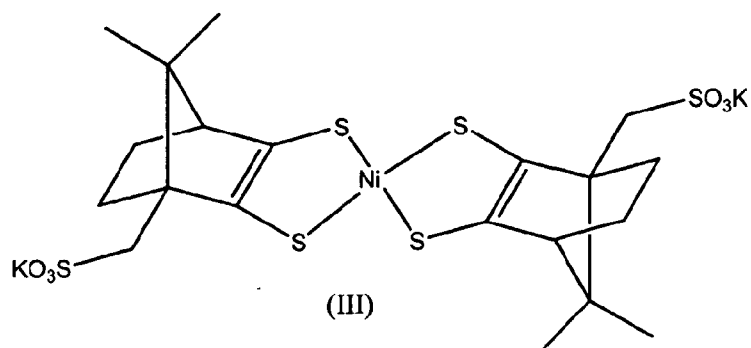

This compound has excellent water-dispersibility combined with minimal absorption in the visible region of the spectrum. It absorbs strongly in the near infrared region at a  $\lambda_{\max}$  of 781 nm.

5

#### Inkjet Inks

Aspects of the present invention are concerned with inkjet inks. Preferably, the inkjet ink is a water-based inkjet ink.

Water-based inkjet ink compositions are well known in the literature and, in addition to water, may comprise additives, such as co-solvents, biocides, sequestering agents, humectants, pH adjusters, viscosity modifiers, penetrants, wetting agents, surfactants *etc.*

Co-solvents are typically water-soluble organic solvents. Suitable water-soluble organic solvents include C<sub>1-4</sub> alkyl alcohols, such as ethanol, methanol, butanol, propanol, and 2-propanol; glycol ethers, such as ethylene glycol monomethyl ether, ethylene glycol monoethyl ether, ethylene glycol monobutyl ether, ethylene glycol monomethyl ether acetate, diethylene glycol monomethyl ether, diethylene glycol monoethyl ether, diethylene glycol mono-n-propyl ether, ethylene glycol mono-isopropyl ether, diethylene glycol mono-isopropyl ether, ethylene glycol mono-n-butyl ether, diethylene glycol mono-n-butyl ether, triethylene glycol mono-n-butyl ether, ethylene glycol mono-t-butyl ether, diethylene glycol mono-t-butyl ether, 1-methyl-1-methoxybutanol, propylene glycol monomethyl ether, propylene glycol monoethyl ether, propylene glycol mono-t-butyl ether, propylene glycol mono-n-propyl ether, propylene glycol mono-isopropyl ether, dipropylene glycol monomethyl ether, dipropylene glycol monoethyl ether, dipropylene glycol mono-n-propyl ether, dipropylene glycol mono-isopropyl ether, propylene glycol mono-n-butyl ether, and dipropylene glycol mono-n-butyl ether;

20

formamide, acetamide, dimethyl sulfoxide, sorbitol, sorbitan, glycerol monoacetate, glycerol diacetate, glycerol triacetate, and sulfolane; or combinations thereof.

Other useful water-soluble organic solvents include polar solvents, such as 2-pyrrolidone, N-methylpyrrolidone,  $\epsilon$ -caprolactam, dimethyl sulfoxide, sulfolane, morpholine, N-ethylmorpholine, 1,3-dimethyl-2-imidazolidinone and combinations thereof.

The inkjet ink may contain a high-boiling water-soluble organic solvent which can serve as a wetting agent or humectant for imparting water retentivity and wetting properties to the ink composition. Such a high-boiling water-soluble organic solvent includes one having a boiling point of 180°C or higher. Examples of the water-soluble organic solvent having a boiling point of 180°C or higher are ethylene glycol, propylene glycol, diethylene glycol, pentamethylene glycol, trimethylene glycol, 2-butene-1,4-diol, 2-ethyl-1,3-hexanediol, 2-methyl-2,4-pentanediol, tripropylene glycol monomethyl ether, dipropylene glycol monoethyl glycol, dipropylene glycol monoethyl ether, dipropylene glycol monomethyl ether, dipropylene glycol, triethylene glycol monomethyl ether, tetraethylene glycol, triethylene glycol, diethylene glycol monobutyl ether, diethylene glycol monoethyl ether, diethylene glycol monomethyl ether, tripropylene glycol, polyethylene glycols having molecular weights of 2000 or lower, 1,3-propylene glycol, isopropylene glycol, isobutylene glycol, 1,4-butanediol, 1,3-butanediol, 1,5-pentanediol, 1,6-hexanediol, glycerol, erythritol, pentaerythritol and combinations thereof.

The total water-soluble organic solvent content in the inkjet ink is preferably about 5 to 50% by weight, more preferably 10 to 30% by weight, based on the total ink composition.

Other suitable wetting agents or humectants include saccharides (including monosaccharides, oligosaccharides and polysaccharides) and derivatives thereof (*e.g.* maltitol, sorbitol, xylitol, hyaluronic salts, aldonic acids, uronic acids *etc.*)

The inkjet ink may also contain a penetrant for accelerating penetration of the aqueous ink into the recording medium. Suitable penetrants include polyhydric alcohol alkyl ethers (glycol ethers) and/or 1,2-alkyldiols. Examples of suitable polyhydric alcohol alkyl ethers are ethylene glycol monomethyl ether, ethylene glycol monoethyl ether, ethylene glycol monobutyl ether, ethylene glycol monomethyl ether acetate, diethylene glycol monomethyl ether, diethylene glycol monoethyl ether, ethylene glycol mono-n-propyl ether, ethylene glycol mono-isopropyl ether, diethylene glycol mono-isopropyl ether, ethylene glycol mono-n-butyl ether, diethylene glycol mono-n-butyl ether, triethylene glycol mono-n-butyl ether, ethylene

glycol mono-t-butyl ether, diethylene glycol mono-t-butyl ether, 1-methyl-1-methoxybutanol, propylene glycol monomethyl ether, propylene glycol monoethyl ether, propylene glycol mono-t-butyl ether, propylene glycol mono-n-propyl ether, propylene glycol mono-isopropyl ether, dipropylene glycol monomethyl ether, dipropylene glycol monoethyl ether, dipropylene glycol mono-n-propyl ether, dipropylene glycol mono-isopropyl ether, propylene glycol mono-n-butyl ether, and dipropylene glycol mono-n-butyl ether. Examples of suitable 1,2-alkyldiols are 1,2-pentanediol and 1,2-hexanediol. The penetrant may also be selected from straight-chain hydrocarbon diols, such as 1,3-propanediol, 1,4-butanediol, 1,5-pentanediol, 1,6-hexanediol, 1,7-heptanediol, and 1,8-octanediol. Glycerol may also be used as a penetrant.

10 The amount of penetrant is preferably in the range of 1 to 20% by weight, more preferably 1 to 10% by weight, based on the total ink composition.

The inkjet ink may also contain a surface active agent, especially an anionic surface active agent and/or a nonionic surface active agent. Useful anionic surface active agents include sulfonic acid types, such as alkanesulfonic acid salts,  $\alpha$ -olefinsulfonic acid salts, 15 alkylbenzenesulfonic acid salts, alkylnaphthalenesulfonic acids, acylmethyltaurines, and dialkylsulfosuccinic acids; alkylsulfuric ester salts, sulfated oils, sulfated olefins, polyoxyethylene alkyl ether sulfuric ester salts; carboxylic acid types, *e.g.*, fatty acid salts and alkylsarcosine salts; and phosphoric acid ester types, such as alkylphosphoric ester salts, polyoxyethylene alkyl ether phosphoric ester salts, and glycerophosphoric ester salts. Specific 20 examples of the anionic surface active agents are sodium dodecylbenzenesulfonate, sodium laurate, and a polyoxyethylene alkyl ether sulfate ammonium salt.

Suitable nonionic surface active agents include ethylene oxide adduct types, such as polyoxyethylene alkyl ethers, polyoxyethylene alkylphenyl ethers, polyoxyethylene alkyl esters, and polyoxyethylene alkylamides; polyol ester types, such as glycerol alkyl esters, 25 sorbitan alkyl esters, and sugar alkyl esters; polyether types, such as polyhydric alcohol alkyl ethers; and alkanolamide types, such as alkanolamine fatty acid amides. Specific examples of nonionic surface active agents are ethers such as polyoxyethylene nonylphenyl ether, polyoxyethylene octylphenyl ether, polyoxyethylene dodecylphenyl ether, polyoxyethylene alkylallyl ether, polyoxyethylene oleyl ether, polyoxyethylene lauryl ether, and 30 polyoxyalkylene alkyl ethers (*e.g.* polyoxyethylene alkyl ethers); and esters, such as polyoxyethylene oleate, polyoxyethylene oleate ester, polyoxyethylene distearate, sorbitan

laurate, sorbitan monostearate, sorbitan mono-oleate, sorbitan sesquioleate, polyoxyethylene mono-oleate, and polyoxyethylene stearate. Acetylene glycol surface active agents, such as 2,4,7,9-tetramethyl-5-decyne-4,7-diol, 3,6-dimethyl-4-octyne-3,6-diol or 3,5-dimethyl-1-hexyn-3-ol, may also be used.

5           The inkjet ink may contain a pH adjuster for adjusting its pH to 7 to 9. Suitable pH adjusters include basic compounds, such as sodium hydroxide, potassium hydroxide, lithium hydroxide, sodium carbonate, sodium hydrogencarbonate, potassium carbonate, potassium hydrogencarbonate, lithium carbonate, sodium phosphate, potassium phosphate, lithium phosphate, potassium dihydrogenphosphate, dipotassium hydrogenphosphate, sodium oxalate,  
10       potassium oxalate, lithium oxalate, sodium borate, sodium tetraborate, potassium hydrogenphthalate, and potassium hydrogentartrate; ammonia; and amines, such as methylamine, ethylamine, diethylamine, trimethylamine, triethylamine, tris(hydroxymethyl)aminomethane hydrochloride, triethanolamine, diethanolamine, diethylethanolamine, triisopropanolamine, butyldiethanolamine, morpholine, and  
15       propanolamine.

          The inkjet ink may also include a biocide, such as benzoic acid, dichlorophene, hexachlorophene, sorbic acid, hydroxybenzoic esters, sodium dehydroacetate, 1,2-benthiazolin-3-one, 3,4-isothiazolin-3-one or 4,4-dimethyloxazolidine.

          The inkjet ink may also contain a sequestering agent, such as  
20       ethylenediaminetetraacetic acid (EDTA).

          The inkjet ink may also contain a singlet oxygen quencher. The presence of singlet oxygen quencher(s) in the ink reduces the propensity for the IR-absorbing dye to degrade. The quencher consumes any singlet oxygen generated in the vicinity of the dye molecules and, hence, minimizes their degradation. An excess of singlet oxygen quencher is advantageous for  
25       minimizing degradation of the dye and retaining its IR-absorbing properties over time. Preferably, the singlet oxygen quencher is selected from ascorbic acid, 1,4-diazabicyclo-[2.2.2]octane (DABCO), azides (*e.g.* sodium azide), histidine or tryptophan.

### Inkjet Printers

30           Aspects of the present invention are concerned with inkjet printers.

2004228065 04 May 2007

Inkjet printers, such as thermal bubble-jet and piezoelectric printers, are well known in the art and will form part of the skilled person's common general knowledge. The printer may be a high-speed inkjet printer. The printer is preferably a pagewidth printer.

5 In one preferred form, the printhead comprises:

a plurality of nozzles;

a bubble forming chamber corresponding to each of the nozzles respectively, the bubble forming chambers adapted to contain ejectable liquid; and

10 a heater element disposed in each of the bubble forming chambers respectively, the heater element configured for thermal contact with the ejectable liquid; such that,

heating the heater element to a temperature above the boiling point of the ejectable liquid forms a gas bubble that causes the ejection of a drop of the ejectable liquid from the nozzle; wherein,

15 the heater element is suspended in the ink chamber such that during use at least a portion of the heater element is encircled by, and in direct contact with, the ejectable fluid.

There now follows a brief description of a printhead suitable for use in the present invention. With reference to Figure 17, the unit cell 1001 of a printhead according to an embodiment of the invention comprises a nozzle plate 1002 with nozzles 1003 therein, the nozzles having nozzle rims 1004, and apertures 1005 extending through the nozzle plate. The nozzle plate 1002 is plasma etched from a silicon nitride structure which is deposited, by way of chemical vapor deposition (CVD), over a sacrificial material which is subsequently etched.

25 The printhead also includes, with respect to each nozzle 1003, side walls 1006 on which the nozzle plate is supported, a chamber 1007 defined by the walls and the nozzle plate 1002, a multi-layer substrate 1008 and an inlet passage 1009 extending through the multi-layer

substrate to the far side (not shown) of the substrate. A looped, elongate heater element 1010 is suspended within the chamber 1007, so that the element is in the form of a suspended beam. The printhead as shown is a microelectromechanical system (MEMS) structure, which is formed by a lithographic process.

5           When the printhead is in use, ink 1011 from a reservoir (not shown) enters the chamber 1007 via the inlet passage 1009, so that the chamber fills. Thereafter, the heater element 1010 is heated for somewhat less than 1 micro second, so that the heating is in the form of a thermal pulse. It will be appreciated that the heater element 1010 is in thermal contact with the ink 1011 in the chamber 1007 so that when the element is heated, this causes the generation of  
10 vapor bubbles in the ink. Accordingly, the ink 1011 constitutes a bubble forming liquid.

The bubble 1012, once generated, causes an increase in pressure within the chamber 1007, which in turn causes the ejection of a drop 1016 of the ink 1011 through the nozzle 1003. The rim 1004 assists in directing the drop 1016 as it is ejected, so as to minimize the chance of a drop misdirection.

15           The reason that there is only one nozzle 1003 and chamber 1007 per inlet passage 1009 is so that the pressure wave generated within the chamber, on heating of the element 1010 and forming of a bubble 1012, does not effect adjacent chambers and their corresponding nozzles.

The increase in pressure within the chamber 1007 not only pushes ink 1011 out through the nozzle 1003, but also pushes some ink back through the inlet passage 1009. However, the  
20 inlet passage 1009 is approximately 200 to 300 microns in length, and is only approximately 16 microns in diameter. Hence there is a substantial viscous drag. As a result, the predominant effect of the pressure rise in the chamber 1007 is to force ink out through the nozzle 1003 as an ejected drop 1016, rather than back through the inlet passage 9.

As shown in Figure 17, the ink drop 1016 is being ejected is shown during its “necking  
25 phase” before the drop breaks off. At this stage, the bubble 1012 has already reached its maximum size and has then begun to collapse towards the point of collapse 1017.

The collapsing of the bubble 1012 towards the point of collapse 1017 causes some ink 1011 to be drawn from within the nozzle 1003 (from the sides 1018 of the drop), and some to be drawn from the inlet passage 1009, towards the point of collapse. Most of the ink 1011  
30 drawn in this manner is drawn from the nozzle 1003, forming an annular neck 1019 at the base of the drop 16 prior to its breaking off.

The drop 1016 requires a certain amount of momentum to overcome surface tension forces, in order to break off. As ink 1011 is drawn from the nozzle 1003 by the collapse of the bubble 1012, the diameter of the neck 1019 reduces thereby reducing the amount of total surface tension holding the drop, so that the momentum of the drop as it is ejected out of the nozzle is sufficient to allow the drop to break off.

When the drop 1016 breaks off, cavitation forces are caused as reflected by the arrows 1020, as the bubble 1012 collapses to the point of collapse 1017. It will be noted that there are no solid surfaces in the vicinity of the point of collapse 1017 on which the cavitation can have an effect.

10        *Inkjet Cartridges*

Aspects of the present invention are concerned with inkjet cartridges. Ink cartridges for inkjet printers are well known in the art and are available in numerous forms. Preferably, the inkjet ink cartridges of the present invention are replaceable.

In one preferred form, the ink cartridge comprises:

15        a housing defining a plurality of storage areas wherein at least one of the storage areas contains colorant for printing information that is visible to the human eye and at least one of the other storage areas contains an inkjet ink as described above.

Preferably, each storage area is sized corresponding to the expected levels of use of its contents relative to the intended print coverage for a number of printed pages.

20        There now follows a brief description of an ink cartridge according to the present invention. Figure 12 shows the complete assembly of the replaceable ink cartridge 627. It has bladders or chambers for storing fixative 644, adhesive 630, and cyan 631, magenta 632, yellow 633, black 634 and infrared 635 inks. The cartridge 627 also contains a micro air filter

636 in a base molding 637. As shown in Figure 9, the micro air filter 636 interfaces with an air pump 638 inside the printer via a hose 639. This provides filtered air to the printheads 705 to prevent ingress of micro particles into the Memjet™ printheads 705 which may clog the nozzles. By incorporating the air filter 636 within the cartridge 627, the operational life of the filter is effectively linked to the life of the cartridge. This ensures that the filter is replaced together with the cartridge rather than relying on the user to clean or replace the filter at the required intervals. Furthermore, the adhesive and infrared ink are replenished together with the visible inks and air filter thereby reducing how frequently the printer operation is interrupted because of the depletion of a consumable material.

10 The cartridge 627 has a thin wall casing 640. The ink bladders 631 to 635 and fixative bladder 644 are suspended within the casing by a pin 645 which hooks the cartridge together. The single glue bladder 630 is accommodated in the base molding 637. This is a fully recyclable product with a capacity for printing and gluing 3000 pages (1500 sheets).

### 15 Substrates

As mentioned above, the present invention is especially suitable for use in connection with Hyperlabel™ and netpage systems. Such systems are described in more detail below and in the patent applications listed above, all of which are incorporated herein by reference in their entirety.

20 Hence, the present invention provides a substrate having an IR-absorbing dye as described above disposed thereon. Preferably, the substrate comprises an interface surface. Preferably, the dye is disposed in the form of coded data suitable for use in netpage and/or Hyperlabel™ systems. For example, the coded data may be indicative of the identity of a product item. Preferably, the coded data is disposed over a substantial portion of an interface surface of the substrate (*e.g.* greater than 20%, greater than 50% or greater than 90% of the surface).

Preferably, the substrate is IR reflective so that the dye disposed thereon may be detected by a sensing device. The substrate may be comprised of any suitable material such as plastics (*e.g.* polyolefins, polyesters, polyamides *etc.*), paper, metal or combinations thereof.

30 For netpage applications, the substrate is preferably a paper sheet. For Hyperlabel™ applications, the substrate is preferably a tag, a label, a packaging material or a surface of a



product item. Typically, tags and labels are comprised of plastics, paper or combinations thereof.

In accordance with Hyperlabel™ applications of the invention, the substrate may be an interactive product item adapted for interaction with a user via a sensing device and a computer system, the interactive product item comprising:

a product item having an identity;

an interface surface associated with the product item and having disposed thereon information relating to the product item and coded data indicative of the identity of the product item, wherein said coded data comprise an IR-absorbing dye as described above.

10

Netpage and Hyperlabel™

Netpage applications of this invention are described generally above. There now follows a detailed overview of netpage and Hyperlabel™. (Note: Memjet™ and Hyperlabel™ are trade marks of Silverbrook Research Pty Ltd, Australia). It will be appreciated that not every implementation will necessarily embody all or even most of the specific details and extensions discussed below in relation to the basic system. However, the system is described in its most complete form to reduce the need for external reference when attempting to understand the context in which the preferred embodiments and aspects of the present invention operate.

20

In brief summary, the preferred form of the netpage system employs a computer interface in the form of a mapped surface, that is, a physical surface which contains references to a map of the surface maintained in a computer system. The map references can be queried by an appropriate sensing device. Depending upon the specific implementation, the map references may be encoded visibly or invisibly, and defined in such a way that a local query on the mapped surface yields an unambiguous map reference both within the map and among different maps. The computer system can contain information about features on the mapped surface, and such information can be retrieved based on map references supplied by a sensing device used with the mapped surface. The information thus retrieved can take the form of actions which are initiated by the computer system on behalf of the operator in response to the operator's interaction with the surface features.

30

In its preferred form, the netpage system relies on the production of, and human interaction with, netpages. These are pages of text, graphics and images printed on ordinary paper, but which work like interactive web pages. Information is encoded on each page using ink which is substantially invisible to the unaided human eye. The ink, however, and thereby  
5 the coded data, can be sensed by an optically imaging pen and transmitted to the netpage system.

In the preferred form, active buttons and hyperlinks on each page can be clicked with the pen to request information from the network or to signal preferences to a network server. In one embodiment, text written by hand on a netpage is automatically recognized and converted  
10 to computer text in the netpage system, allowing forms to be filled in. In other embodiments, signatures recorded on a netpage are automatically verified, allowing e-commerce transactions to be securely authorized.

As illustrated in Figure 1, a printed netpage 1 can represent an interactive form which can be filled in by the user both physically, on the printed page, and "electronically", via  
15 communication between the pen and the netpage system. The example shows a "Request" form containing name and address fields and a submit button. The netpage consists of graphic data 2 printed using visible ink, and coded data 3 printed as a collection of tags 4 using invisible ink. The corresponding page description 5, stored on the netpage network, describes the individual elements of the netpage. In particular it describes the type and spatial extent (zone) of each  
20 interactive element (i.e. text field or button in the example), to allow the netpage system to correctly interpret input via the netpage. The submit button 6, for example, has a zone 7 which corresponds to the spatial extent of the corresponding graphic 8.

As illustrated in Figure 2, the netpage pen 101, a preferred form of which is shown in Figures 6 and 7 and described in more detail below, works in conjunction with a personal  
25 computer (PC), Web terminal 75, or a netpage printer 601. The netpage printer is an Internet-connected printing appliance for home, office or mobile use. The pen is wireless and communicates securely with the netpage network via a short-range radio link 9. Short-range communication is relayed to the netpage network by a local relay function which is either embedded in the PC, Web terminal or netpage printer, or is provided by a separate relay device  
30 44. The relay function can also be provided by a mobile phone or other device which incorporates both short-range and longer-range communications functions.

In an alternative embodiment, the netpage pen utilises a wired connection, such as a USB or other serial connection, to the PC, Web terminal, netpage printer or relay device.

The netpage printer 601, a preferred form of which is shown in Figures 9 to 11 and described in more detail below, is able to deliver, periodically or on demand, personalized newspapers, magazines, catalogs, brochures and other publications, all printed at high quality  
5 as interactive netpages. Unlike a personal computer, the netpage printer is an appliance which can be, for example, wall-mounted adjacent to an area where the morning news is first consumed, such as in a user's kitchen, near a breakfast table, or near the household's point of departure for the day. It also comes in tabletop, desktop, portable and miniature versions.

10 Netpages printed at their point of consumption combine the ease-of-use of paper with the timeliness and interactivity of an interactive medium.

As shown in Figure 2, the netpage pen 101 interacts with the coded data on a printed netpage 1 (or product item 201) and communicates the interaction via a short-range radio link 9 to a relay. The relay sends the interaction to the relevant netpage page server 10 for  
15 interpretation. In appropriate circumstances, the page server sends a corresponding message to application computer software running on a netpage application server 13. The application server may in turn send a response which is printed on the originating printer.

In an alternative embodiment, the PC, Web terminal, netpage printer or relay device may communicate directly with local or remote application software, including a local or  
20 remote Web server. Relatedly, output is not limited to being printed by the netpage printer. It can also be displayed on the PC or Web terminal, and further interaction can be screen-based rather than paper-based, or a mixture of the two.

The netpage system is made considerably more convenient in the preferred embodiment by being used in conjunction with high-speed microelectromechanical system  
25 (MEMS) based inkjet (Memjet™) printers. In the preferred form of this technology, relatively high-speed and high-quality printing is made more affordable to consumers. In its preferred form, a netpage publication has the physical characteristics of a traditional newsmagazine, such as a set of letter-size glossy pages printed in full color on both sides, bound together for easy navigation and comfortable handling.

30 The netpage printer exploits the growing availability of broadband Internet access. Cable service is available to 95% of households in the United States, and cable modem service

offering broadband Internet access is already available to 20% of these. The netpage printer can also operate with slower connections, but with longer delivery times and lower image quality. Indeed, the netpage system can be enabled using existing consumer inkjet and laser printers, although the system will operate more slowly and will therefore be less acceptable from a consumer's point of view. In other embodiments, the netpage system is hosted on a private intranet. In still other embodiments, the netpage system is hosted on a single computer or computer-enabled device, such as a printer.

Netpage publication servers 14 on the netpage network are configured to deliver print-quality publications to netpage printers. Periodical publications are delivered automatically to subscribing netpage printers via pointcasting and multicasting Internet protocols. Personalized publications are filtered and formatted according to individual user profiles.

A netpage printer can be configured to support any number of pens, and a pen can work with any number of netpage printers. In the preferred implementation, each netpage pen has a unique identifier. A household may have a collection of colored netpage pens, one assigned to each member of the family. This allows each user to maintain a distinct profile with respect to a netpage publication server or application server.

A netpage pen can also be registered with a netpage registration server 11 and linked to one or more payment card accounts. This allows e-commerce payments to be securely authorized using the netpage pen. The netpage registration server compares the signature captured by the netpage pen with a previously registered signature, allowing it to authenticate the user's identity to an e-commerce server. Other biometrics can also be used to verify identity. A version of the netpage pen includes fingerprint scanning, verified in a similar way by the netpage registration server.

Although a netpage printer may deliver periodicals such as the morning newspaper without user intervention, it can be configured never to deliver unsolicited junk mail. In its preferred form, it only delivers periodicals from subscribed or otherwise authorized sources. In this respect, the netpage printer is unlike a fax machine or e-mail account which is visible to any junk mailer who knows the telephone number or email address.

## **1 NETPAGE SYSTEM ARCHITECTURE**

Each object model in the system is described using a Unified Modeling Language (UML) class diagram. A class diagram consists of a set of object classes connected by rela-

tionships, and two kinds of relationships are of interest here: associations and generalizations. An association represents some kind of relationship between objects, i.e. between instances of classes. A generalization relates actual classes, and can be understood in the following way: if a class is thought of as the set of all objects of that class, and class A is a generalization of class B, then B is simply a subset of A. The UML does not directly support second-order modelling - i.e. classes of classes.

Each class is drawn as a rectangle labelled with the name of the class. It contains a list of the attributes of the class, separated from the name by a horizontal line, and a list of the operations of the class, separated from the attribute list by a horizontal line. In the class diagrams which follow, however, operations are never modelled.

An association is drawn as a line joining two classes, optionally labelled at either end with the multiplicity of the association. The default multiplicity is one. An asterisk (\*) indicates a multiplicity of "many", i.e. zero or more. Each association is optionally labelled with its name, and is also optionally labelled at either end with the role of the corresponding class. An open diamond indicates an aggregation association ("is-part-of"), and is drawn at the aggregator end of the association line.

A generalization relationship ("is-a") is drawn as a solid line joining two classes, with an arrow (in the form of an open triangle) at the generalization end.

When a class diagram is broken up into multiple diagrams, any class which is duplicated is shown with a dashed outline in all but the main diagram which defines it. It is shown with attributes only where it is defined.

## 1.1 NETPAGES

Netpages are the foundation on which a netpage network is built. They provide a paper-based user interface to published information and interactive services.

A netpage consists of a printed page (or other surface region) invisibly tagged with references to an online description of the page. The online page description is maintained persistently by a netpage page server. The page description describes the visible layout and content of the page, including text, graphics and images. It also describes the input elements on the page, including buttons, hyperlinks, and input fields. A netpage allows markings made with a netpage pen on its surface to be simultaneously captured and processed by the netpage system.

Multiple netpages can share the same page description. However, to allow input through otherwise identical pages to be distinguished, each netpage is assigned a unique page identifier. This page ID has sufficient precision to distinguish between a very large number of netpages.

5        Each reference to the page description is encoded in a printed tag. The tag identifies the unique page on which it appears, and thereby indirectly identifies the page description. The tag also identifies its own position on the page. Characteristics of the tags are described in more detail below.

10        Tags are printed in infrared-absorptive ink on any substrate which is infrared-reflective, such as ordinary paper. Near-infrared wavelengths are invisible to the human eye but are easily sensed by a solid-state image sensor with an appropriate filter.

15        A tag is sensed by an area image sensor in the netpage pen, and the tag data is transmitted to the netpage system via the nearest netpage printer. The pen is wireless and communicates with the netpage printer via a short-range radio link. Tags are sufficiently small and densely arranged that the pen can reliably image at least one tag even on a single click on the page. It is important that the pen recognize the page ID and position on every interaction with the page, since the interaction is stateless. Tags are error-correctably encoded to make them partially tolerant to surface damage.

20        The netpage page server maintains a unique page instance for each printed netpage, allowing it to maintain a distinct set of user-supplied values for input fields in the page description for each printed netpage.

25        The relationship between the page description, the page instance, and the printed netpage is shown in Figure 4. The printed netpage may be part of a printed netpage document 45. The page instance is associated with both the netpage printer which printed it and, if known, the netpage user who requested it.

As shown in Figure 4, one or more netpages may also be associated with a physical object such as a product item, for example when printed onto the product item's label, packaging, or actual surface.

## **1.2    NETPAGE TAGS**

### **30    1.2.1   Tag Data Content**

In a preferred form, each tag identifies the region in which it appears, and the location of that tag within the region. A tag may also contain flags which relate to the region as a whole or to the tag. One or more flag bits may, for example, signal a tag sensing device to provide feedback indicative of a function associated with the immediate area of the tag, without the sensing device having to refer to a description of the region. A netpage pen may, for example, illuminate an "active area" LED when in the zone of a hyperlink.

As will be more clearly explained below, in a preferred embodiment, each tag contains an easily recognized invariant structure which aids initial detection, and which assists in minimizing the effect of any warp induced by the surface or by the sensing process. The tags preferably tile the entire page, and are sufficiently small and densely arranged that the pen can reliably image at least one tag even on a single click on the page. It is important that the pen recognize the page ID and position on every interaction with the page, since the interaction is stateless.

In a preferred embodiment, the region to which a tag refers coincides with an entire page, and the region ID encoded in the tag is therefore synonymous with the page ID of the page on which the tag appears. In other embodiments, the region to which a tag refers can be an arbitrary subregion of a page or other surface. For example, it can coincide with the zone of an interactive element, in which case the region ID can directly identify the interactive element.

In the preferred form, each tag contains 120 bits of information. The region ID is typically allocated up to 100 bits, the tag ID at least 16 bits, and the remaining bits are allocated to flags etc. Assuming a tag density of 64 per square inch, a 16-bit tag ID supports a region size of up to 1024 square inches. Larger regions can be mapped continuously without increasing the tag ID precision simply by using abutting regions and maps. The 100-bit region ID allows  $2^{100}$  ( $\sim 10^{30}$  or a million trillion trillion) different regions to be uniquely identified.

### **1.2.2 Tag Data Encoding**

In one embodiment, the 120 bits of tag data are redundantly encoded using a (15, 5) Reed-Solomon code. This yields 360 encoded bits consisting of 6 codewords of 15 4-bit symbols each. The (15, 5) code allows up to 5 symbol errors to be corrected per codeword, i.e. it is tolerant of a symbol error rate of up to 33% per codeword.

Each 4-bit symbol is represented in a spatially coherent way in the tag, and the symbols of the six codewords are interleaved spatially within the tag. This ensures that a burst error (an error affecting multiple spatially adjacent bits) damages a minimum number of symbols overall and a minimum number of symbols in any one codeword, thus maximising the likelihood that the burst error can be fully corrected.

Any suitable error-correcting code can be used in place of a (15, 5) Reed-Solomon code, for example: a Reed-Solomon code with more or less redundancy, with the same or different symbol and codeword sizes; another block code; or a different kind of code, such as a convolutional code (see, for example, Stephen B. Wicker, Error Control Systems for Digital Communication and Storage, Prentice-Hall 1995, the contents of which are herein incorporated by reference thereto).

In order to support "single-click" interaction with a tagged region via a sensing device, the sensing device must be able to see at least one entire tag in its field of view no matter where in the region or at what orientation it is positioned. The required diameter of the field of view of the sensing device is therefore a function of the size and spacing of the tags.

### 1.2.3 Tag Structure

Figure 5a shows a tag 4, in the form of tag 726 with four perspective targets 17. The tag 726 represents sixty 4-bit Reed-Solomon symbols 747, for a total of 240 bits. The tag represents each "one" bit by the presence of a mark 748, referred to as a macrodot, and each "zero" bit by the absence of the corresponding macrodot. Figure 5c shows a square tiling 728 of nine tags, containing all "one" bits for illustrative purposes. It will be noted that the perspective targets are designed to be shared between adjacent tags. Figure 5d shows a square tiling of 16 tags and a corresponding minimum field of view 193, which spans the diagonals of two tags.

Using a (15, 7) Reed-Solomon code, 112 bits of tag data are redundantly encoded to produce 240 encoded bits. The four codewords are interleaved spatially within the tag to maximize resilience to burst errors. Assuming a 16-bit tag ID as before, this allows a region ID of up to 92 bits.

The data-bearing macrodots 748 of the tag are designed to not overlap their neighbors, so that groups of tags cannot produce structures that resemble targets. This also saves ink. The perspective targets allow detection of the tag, so further targets are not required.



Although the tag may contain an orientation feature to allow disambiguation of the four possible orientations of the tag relative to the sensor, the present invention is concerned with embedding orientation data in the tag data. For example, the four codewords can be arranged so that each tag orientation (in a rotational sense) contains one codeword placed at that orientation, as shown in Figure 5a, where each symbol is labelled with the number of its codeword (1-4) and the position of the symbol within the codeword (A-O). Tag decoding then consists of decoding one codeword at each rotational orientation. Each codeword can either contain a single bit indicating whether it is the first codeword, or two bits indicating which codeword it is. The latter approach has the advantage that if, say, the data content of only one codeword is required, then at most two codewords need to be decoded to obtain the desired data. This may be the case if the region ID is not expected to change within a stroke and is thus only decoded at the start of a stroke. Within a stroke only the codeword containing the tag ID is then desired. Furthermore, since the rotation of the sensing device changes slowly and predictably within a stroke, only one codeword typically needs to be decoded per frame.

It is possible to dispense with perspective targets altogether and instead rely on the data representation being self-registering. In this case each bit value (or multi-bit value) is typically represented by an explicit glyph, i.e. no bit value is represented by the absence of a glyph. This ensures that the data grid is well-populated, and thus allows the grid to be reliably identified and its perspective distortion detected and subsequently corrected during data sampling. To allow tag boundaries to be detected, each tag data must contain a marker pattern, and these must be redundantly encoded to allow reliable detection. The overhead of such marker patterns is similar to the overhead of explicit perspective targets. Various such schemes are described in the present applicants' co-pending PCT application PCT/AU01/01274 filed 11 October 2001.

The arrangement 728 of Figure 5c shows that the square tag 726 can be used to fully tile or tessellate, i.e. without gaps or overlap, a plane of arbitrary size.

Although in preferred embodiments the tagging schemes described herein encode a single data bit using the presence or absence of a single undifferentiated macrodot, they can also use sets of differentiated glyphs to represent single-bit or multi-bit values, such as the sets of glyphs illustrated in the present applicants' co-pending PCT application PCT/AU01/01274 filed 11 October 2001.

### 1.3 THE NETPAGE NETWORK

In a preferred embodiment, a netpage network consists of a distributed set of netpage page servers 10, netpage registration servers 11, netpage ID servers 12, netpage application servers 13, netpage publication servers 14, Web terminals 75, netpage printers 601, and relay devices 44 connected via a network 19 such as the Internet, as shown in Figure 3.

The netpage registration server 11 is a server which records relationships between users, pens, printers, applications and publications, and thereby authorizes various network activities. It authenticates users and acts as a signing proxy on behalf of authenticated users in application transactions. It also provides handwriting recognition services. As described above, a netpage page server 10 maintains persistent information about page descriptions and page instances. The netpage network includes any number of page servers, each handling a subset of page instances. Since a page server also maintains user input values for each page instance, clients such as netpage printers send netpage input directly to the appropriate page server. The page server interprets any such input relative to the description of the corresponding page.

A netpage ID server 12 allocates document IDs 51 on demand, and provides load-balancing of page servers via its ID allocation scheme.

A netpage printer uses the Internet Distributed Name System (DNS), or similar, to resolve a netpage page ID 50 into the network address of the netpage page server handling the corresponding page instance.

A netpage application server 13 is a server which hosts interactive netpage applications. A netpage publication server 14 is an application server which publishes netpage documents to netpage printers.

Netpage servers can be hosted on a variety of network server platforms from manufacturers such as IBM, Hewlett-Packard, and Sun. Multiple netpage servers can run concurrently on a single host, and a single server can be distributed over a number of hosts. Some or all of the functionality provided by netpage servers, and in particular the functionality provided by the ID server and the page server, can also be provided directly in a netpage appliance such as a netpage printer, in a computer workstation, or on a local network.

### 1.4 THE NETPAGE PRINTER

The netpage printer 601 is an appliance which is registered with the netpage system and prints netpage documents on demand and via subscription. Each printer has a unique

printer ID 62, and is connected to the netpage network via a network such as the Internet, ideally via a broadband connection.

Apart from identity and security settings in non-volatile memory, the netpage printer contains no persistent storage. As far as a user is concerned, "the network is the computer".

5 Netpages function interactively across space and time with the help of the distributed netpage page servers 10, independently of particular netpage printers.

The netpage printer receives subscribed netpage documents from netpage publication servers 14. Each document is distributed in two parts: the page layouts, and the actual text and image objects which populate the pages. Because of personalization, page layouts are typically  
10 specific to a particular subscriber and so are pointcast to the subscriber's printer via the appropriate page server. Text and image objects, on the other hand, are typically shared with other subscribers, and so are multicast to all subscribers' printers and the appropriate page servers.

The netpage publication server optimizes the segmentation of document content into  
15 pointcasts and multicasts. After receiving the pointcast of a document's page layouts, the printer knows which multicasts, if any, to listen to.

Once the printer has received the complete page layouts and objects that define the document to be printed, it can print the document.

The printer rasterizes and prints odd and even pages simultaneously on both sides of  
20 the sheet. It contains duplexed print engine controllers 760 and print engines utilizing Memjet™ printheads 350 for this purpose.

The printing process consists of two decoupled stages: rasterization of page descriptions, and expansion and printing of page images. The raster image processor (RIP) consists of one or more standard DSPs 757 running in parallel. The duplexed print engine  
25 controllers consist of custom processors which expand, dither and print page images in real time, synchronized with the operation of the printheads in the print engines.

Printers not enabled for IR printing have the option to print tags using IR-absorptive black ink, although this restricts tags to otherwise empty areas of the page. Although such pages have more limited functionality than IR-printed pages, they are still classed as netpages.

30 A normal netpage printer prints netpages on sheets of paper. More specialised netpage printers may print onto more specialised surfaces, such as globes. Each printer sup-

ports at least one surface type, and supports at least one tag tiling scheme, and hence tag map, for each surface type. The tag map 811 which describes the tag tiling scheme actually used to print a document becomes associated with that document so that the document's tags can be correctly interpreted.

5           Figure 2 shows the netpage printer class diagram, reflecting printer-related information maintained by a registration server 11 on the netpage network.

### 1.5 THE NETPAGE PEN

10           The active sensing device of the netpage system is typically a pen 101, which, using its embedded controller 134, is able to capture and decode IR position tags from a page via an image sensor. The image sensor is a solid-state device provided with an appropriate filter to permit sensing at only near-infrared wavelengths. As described in more detail below, the system is able to sense when the nib is in contact with the surface, and the pen is able to sense tags at a sufficient rate to capture human handwriting (i.e. at 200 dpi or greater and 100 Hz or faster). Information captured by the pen is encrypted and wirelessly transmitted to the printer (or base station), the printer or base station interpreting the data with respect to the (known) page structure.

15           The preferred embodiment of the netpage pen operates both as a normal marking ink pen and as a non-marking stylus. The marking aspect, however, is not necessary for using the netpage system as a browsing system, such as when it is used as an Internet interface. Each netpage pen is registered with the netpage system and has a unique pen ID 61. Figure 14 shows the netpage pen class diagram, reflecting pen-related information maintained by a registration server 11 on the netpage network.

20           When either nib is in contact with a netpage, the pen determines its position and orientation relative to the page. The nib is attached to a force sensor, and the force on the nib is interpreted relative to a threshold to indicate whether the pen is "up" or "down". This allows a interactive element on the page to be 'clicked' by pressing with the pen nib, in order to request, say, information from a network. Furthermore, the force is captured as a continuous value to allow, say, the full dynamics of a signature to be verified.

25           The pen determines the position and orientation of its nib on the netpage by imaging, in the infrared spectrum, an area 193 of the page in the vicinity of the nib. It decodes the nearest tag and computes the position of the nib relative to the tag from the observed per-

spective distortion on the imaged tag and the known geometry of the pen optics. Although the position resolution of the tag may be low, because the tag density on the page is inversely proportional to the tag size, the adjusted position resolution is quite high, exceeding the minimum resolution required for accurate handwriting recognition.

5 Pen actions relative to a netpage are captured as a series of strokes. A stroke consists of a sequence of time-stamped pen positions on the page, initiated by a pen-down event and completed by the subsequent pen-up event. A stroke is also tagged with the page ID 50 of the netpage whenever the page ID changes, which, under normal circumstances, is at the commencement of the stroke.

10 Each netpage pen has a current selection 826 associated with it, allowing the user to perform copy and paste operations etc. The selection is timestamped to allow the system to discard it after a defined time period. The current selection describes a region of a page instance. It consists of the most recent digital ink stroke captured through the pen relative to the background area of the page. It is interpreted in an application-specific manner once it is  
15 submitted to an application via a selection hyperlink activation.

Each pen has a current nib 824. This is the nib last notified by the pen to the system. In the case of the default netpage pen described above, either the marking black ink nib or the non-marking stylus nib is current. Each pen also has a current nib style 825. This is the nib style last associated with the pen by an application, e.g. in response to the user selecting a color  
20 from a palette. The default nib style is the nib style associated with the current nib. Strokes captured through a pen are tagged with the current nib style. When the strokes are subsequently reproduced, they are reproduced in the nib style with which they are tagged.

Whenever the pen is within range of a printer with which it can communicate, the pen slowly flashes its "online" LED. When the pen fails to decode a stroke relative to the page, it  
25 momentarily activates its "error" LED. When the pen succeeds in decoding a stroke relative to the page, it momentarily activates its "ok" LED.

A sequence of captured strokes is referred to as digital ink. Digital ink forms the basis for the digital exchange of drawings and handwriting, for online recognition of handwriting, and for online verification of signatures.

30 The pen is wireless and transmits digital ink to the netpage printer via a short-range radio link. The transmitted digital ink is encrypted for privacy and security and packetized for

efficient transmission, but is always flushed on a pen-up event to ensure timely handling in the printer.

When the pen is out-of-range of a printer it buffers digital ink in internal memory, which has a capacity of over ten minutes of continuous handwriting. When the pen is once  
5 again within range of a printer, it transfers any buffered digital ink.

A pen can be registered with any number of printers, but because all state data resides in netpages both on paper and on the network, it is largely immaterial which printer a pen is communicating with at any particular time.

A preferred embodiment of the pen is described in greater detail below, with  
10 reference to Figures 6 to 8.

#### **1.6 NETPAGE INTERACTION**

The netpage printer 601 receives data relating to a stroke from the pen 101 when the pen is used to interact with a netpage 1. The coded data 3 of the tags 4 is read by the pen when it is used to execute a movement, such as a stroke. The data allows the identity of the particular  
15 page and associated interactive element to be determined and an indication of the relative positioning of the pen relative to the page to be obtained. The indicating data is transmitted to the printer, where it resolves, via the DNS, the page ID 50 of the stroke into the network address of the netpage page server 10 which maintains the corresponding page instance 830. It then transmits the stroke to the page server. If the page was recently identified in an earlier  
20 stroke, then the printer may already have the address of the relevant page server in its cache. Each netpage consists of a compact page layout maintained persistently by a netpage page server (see below). The page layout refers to objects such as images, fonts and pieces of text, typically stored elsewhere on the netpage network.

When the page server receives the stroke from the pen, it retrieves the page  
25 description to which the stroke applies, and determines which element of the page description the stroke intersects. It is then able to interpret the stroke in the context of the type of the relevant element.

A "click" is a stroke where the distance and time between the pen down position and the subsequent pen up position are both less than some small maximum. An object which is  
30 activated by a click typically requires a click to be activated, and accordingly, a longer stroke is

ignored. The failure of a pen action, such as a “sloppy” click, to register is indicated by the lack of response from the pen’s “ok” LED.

There are two kinds of input elements in a netpage page description: hyperlinks and form fields. Input through a form field can also trigger the activation of an associated  
5 hyperlink.

## **2 NETPAGE PEN DESCRIPTION**

### **2.1 PEN MECHANICS**

Referring to Figures 6 and 7, the pen, generally designated by reference numeral 101, includes a housing 102 in the form of a plastics moulding having walls 103 defining an interior  
10 space 104 for mounting the pen components. The pen top 105 is in operation rotatably mounted at one end 106 of the housing 102. A semi-transparent cover 107 is secured to the opposite end 108 of the housing 102. The cover 107 is also of moulded plastics, and is formed from semi-transparent material in order to enable the user to view the status of the LED mounted within the housing 102. The cover 107 includes a main part 109 which substantially  
15 surrounds the end 108 of the housing 102 and a projecting portion 110 which projects back from the main part 109 and fits within a corresponding slot 111 formed in the walls 103 of the housing 102. A radio antenna 112 is mounted behind the projecting portion 110, within the housing 102. Screw threads 113 surrounding an aperture 113A on the cover 107 are arranged to receive a metal end piece 114, including corresponding screw threads 115. The metal end  
20 piece 114 is removable to enable ink cartridge replacement.

Also mounted within the cover 107 is a tri-color status LED 116 on a flex PCB 117. The antenna 112 is also mounted on the flex PCB 117. The status LED 116 is mounted at the top of the pen 101 for good all-around visibility.

The pen can operate both as a normal marking ink pen and as a non-marking stylus.  
25 An ink pen cartridge 118 with nib 119 and a stylus 120 with stylus nib 121 are mounted side by side within the housing 102. Either the ink cartridge nib 119 or the stylus nib 121 can be brought forward through open end 122 of the metal end piece 114, by rotation of the pen top 105. Respective slider blocks 123 and 124 are mounted to the ink cartridge 118 and stylus 120, respectively. A rotatable cam barrel 125 is secured to the pen top 105 in operation and arranged  
30 to rotate therewith. The cam barrel 125 includes a cam 126 in the form of a slot within the walls 181 of the cam barrel. Cam followers 127 and 128 projecting from slider blocks 123 and

124 fit within the cam slot 126. On rotation of the cam barrel 125, the slider blocks 123 or 124 move relative to each other to project either the pen nib 119 or stylus nib 121 out through the hole 122 in the metal end piece 114. The pen 101 has three states of operation. By turning the top 105 through 90° steps, the three states are:

- 5
- stylus 120 nib 121 out
  - ink cartridge 118 nib 119 out, and
  - neither ink cartridge 118 nib 119 out nor stylus 120 nib 121 out

A second flex PCB 129, is mounted on an electronics chassis 130 which sits within  
10 the housing 102. The second flex PCB 129 mounts an infrared LED 131 for providing infrared radiation for projection onto the surface. An image sensor 132 is provided mounted on the second flex PCB 129 for receiving reflected radiation from the surface. The second flex PCB 129 also mounts a radio frequency chip 133, which includes an RF transmitter and RF receiver, and a controller chip 134 for controlling operation of the pen 101. An optics block 135 (formed  
15 from moulded clear plastics) sits within the cover 107 and projects an infrared beam onto the surface and receives images onto the image sensor 132. Power supply wires 136 connect the components on the second flex PCB 129 to battery contacts 137 which are mounted within the cam barrel 125. A terminal 138 connects to the battery contacts 137 and the cam barrel 125. A three volt rechargeable battery 139 sits within the cam barrel 125 in contact with the battery  
20 contacts. An induction charging coil 140 is mounted about the second flex PCB 129 to enable recharging of the battery 139 via induction. The second flex PCB 129 also mounts an infrared LED 143 and infrared photodiode 144 for detecting displacement in the cam barrel 125 when either the stylus 120 or the ink cartridge 118 is used for writing, in order to enable a determination of the force being applied to the surface by the pen nib 119 or stylus nib 121.  
25 The IR photodiode 144 detects light from the IR LED 143 via reflectors (not shown) mounted on the slider blocks 123 and 124.

Rubber grip pads 141 and 142 are provided towards the end 108 of the housing 102 to assist gripping the pen 101, and top 105 also includes a clip 142 for clipping the pen 101 to a pocket.

30 **3.2 PEN CONTROLLER**



The pen 101 is arranged to determine the position of its nib (stylus nib 121 or ink cartridge nib 119) by imaging, in the infrared spectrum, an area of the surface in the vicinity of the nib. It records the location data from the nearest location tag, and is arranged to calculate the distance of the nib 121 or 119 from the location tag utilising optics 135 and controller chip 5 134. The controller chip 134 calculates the orientation of the pen and the nib-to-tag distance from the perspective distortion observed on the imaged tag.

Utilising the RF chip 133 and antenna 112 the pen 101 can transmit the digital ink data (which is encrypted for security and packaged for efficient transmission) to the computing system.

10 When the pen is in range of a receiver, the digital ink data is transmitted as it is formed. When the pen 101 moves out of range, digital ink data is buffered within the pen 101 (the pen 101 circuitry includes a buffer arranged to store digital ink data for approximately 12 minutes of the pen motion on the surface) and can be transmitted later.

The controller chip 134 is mounted on the second flex PCB 129 in the pen 101. 15 Figure 8 is a block diagram illustrating in more detail the architecture of the controller chip 134. Figure 8 also shows representations of the RF chip 133, the image sensor 132, the tri-color status LED 116, the IR illumination LED 131, the IR force sensor LED 143, and the force sensor photodiode 144.

The pen controller chip 134 includes a controlling processor 145. Bus 146 enables the 20 exchange of data between components of the controller chip 134. Flash memory 147 and a 512 KB DRAM 148 are also included. An analog-to-digital converter 149 is arranged to convert the analog signal from the force sensor photodiode 144 to a digital signal.

An image sensor interface 152 interfaces with the image sensor 132. A transceiver controller 153 and base band circuit 154 are also included to interface with the RF chip 133 25 which includes an RF circuit 155 and RF resonators and inductors 156 connected to the antenna 112.

The controlling processor 145 captures and decodes location data from tags from the surface via the image sensor 132, monitors the force sensor photodiode 144, controls the LEDs 116, 131 and 143, and handles short-range radio communication via the radio transceiver 153. 30 It is a medium-performance (~40MHz) general-purpose RISC processor.

The processor 145, digital transceiver components (transceiver controller 153 and baseband circuit 154), image sensor interface 152, flash memory 147 and 512KB DRAM 148 are integrated in a single controller ASIC. Analog RF components (RF circuit 155 and RF resonators and inductors 156) are provided in the separate RF chip.

5           The image sensor is a CCD or CMOS image sensor. Depending on tagging scheme, it has a size ranging from about 100x100 pixels to 200x200 pixels. Many miniature CMOS image sensors are commercially available, including the National Semiconductor LM9630.

          The controller ASIC 134 enters a quiescent state after a period of inactivity when the pen 101 is not in contact with a surface. It incorporates a dedicated circuit 150 which monitors  
10       the force sensor photodiode 144 and wakes up the controller 134 via the power manager 151 on a pen-down event.

          The radio transceiver communicates in the unlicensed 900MHz band normally used by cordless telephones, or alternatively in the unlicensed 2.4GHz industrial, scientific and medical (ISM) band, and uses frequency hopping and collision detection to provide  
15       interference-free communication.

          In an alternative embodiment, the pen incorporates an Infrared Data Association (IrDA) interface for short-range communication with a base station or netpage printer.

          In a further embodiment, the pen 101 includes a pair of orthogonal accelerometers mounted in the normal plane of the pen 101 axis. The accelerometers 190 are shown in Figures  
20       7 and 8 in ghost outline.

          The provision of the accelerometers enables this embodiment of the pen 101 to sense motion without reference to surface location tags, allowing the location tags to be sampled at a lower rate. Each location tag ID can then identify an object of interest rather than a position on the surface. For example, if the object is a user interface input element (e.g. a command  
25       button), then the tag ID of each location tag within the area of the input element can directly identify the input element.

          The acceleration measured by the accelerometers in each of the x and y directions is integrated with respect to time to produce an instantaneous velocity and position.

          Since the starting position of the stroke is not known, only relative positions within a  
30       stroke are calculated. Although position integration accumulates errors in the sensed

acceleration, accelerometers typically have high resolution, and the time duration of a stroke, over which errors accumulate, is short.

### **3 NETPAGE PRINTER DESCRIPTION**

#### **3.1 PRINTER MECHANICS**

5 The vertically-mounted netpage wallprinter 601 is shown fully assembled in Figure 9. It prints netpages on Letter/A4 sized media using duplexed 8½" Memjet™ print engines 602 and 603, as shown in Figures 10 and 10a. It uses a straight paper path with the paper 604 passing through the duplexed print engines 602 and 603 which print both sides of a sheet simultaneously, in full color and with full bleed.

10 An integral binding assembly 605 applies a strip of glue along one edge of each printed sheet, allowing it to adhere to the previous sheet when pressed against it. This creates a final bound document 618 which can range in thickness from one sheet to several hundred sheets.

The replaceable ink cartridge 627, shown in Figure 12 coupled with the duplexed  
15 print engines, has bladders or chambers for storing fixative, adhesive, and cyan, magenta, yellow, black and infrared inks. The cartridge also contains a micro air filter in a base molding. The micro air filter interfaces with an air pump 638 inside the printer via a hose 639. This provides filtered air to the printheads to prevent ingress of micro particles into the Memjet™  
20 printheads 350 which might otherwise clog the printhead nozzles. By incorporating the air filter within the cartridge, the operational life of the filter is effectively linked to the life of the cartridge. The ink cartridge is a fully recyclable product with a capacity for printing and gluing 3000 pages (1500 sheets).

Referring to Figure 10, the motorized media pick-up roller assembly 626 pushes the top sheet directly from the media tray past a paper sensor on the first print engine 602 into the  
25 duplexed Memjet™ printhead assembly. The two Memjet™ print engines 602 and 603 are mounted in an opposing in-line sequential configuration along the straight paper path. The paper 604 is drawn into the first print engine 602 by integral, powered pick-up rollers 626. The position and size of the paper 604 is sensed and full bleed printing commences. Fixative is printed simultaneously to aid drying in the shortest possible time.

The paper exits the first Memjet™ print engine 602 through a set of powered exit spike wheels (aligned along the straight paper path), which act against a rubberized roller. These spike wheels contact the 'wet' printed surface and continue to feed the sheet 604 into the second Memjet™ print engine 603.

5 Referring to Figures 10 and 10a, the paper 604 passes from the duplexed print engines 602 and 603 into the binder assembly 605. The printed page passes between a powered spike wheel axle 670 with a fibrous support roller and another movable axle with spike wheels and a momentary action glue wheel. The movable axle/glue assembly 673 is mounted to a metal support bracket and it is transported forward to interface with the powered axle 670 via  
10 gears by action of a camshaft. A separate motor powers this camshaft.

The glue wheel assembly 673 consists of a partially hollow axle 679 with a rotating coupling for the glue supply hose 641 from the ink cartridge 627. This axle 679 connects to a glue wheel, which absorbs adhesive by capillary action through radial holes. A molded housing 682 surrounds the glue wheel, with an opening at the front. Pivoting side moldings and sprung  
15 outer doors are attached to the metal bracket and hinge out sideways when the rest of the assembly 673 is thrust forward. This action exposes the glue wheel through the front of the molded housing 682. Tension springs close the assembly and effectively cap the glue wheel during periods of inactivity.

As the sheet 604 passes into the glue wheel assembly 673, adhesive is applied to one  
20 vertical edge on the front side (apart from the first sheet of a document) as it is transported down into the binding assembly 605.

#### **4 PRODUCT TAGGING**

Automatic identification refers to the use of technologies such as bar codes, magnetic  
25 stripe cards, smartcards, and RF transponders, to (semi-)automatically identify objects to data processing systems without manual keying.

For the purposes of automatic identification, a product item is commonly identified  
by a 12-digit Universal Product Code (UPC), encoded machine-readably in the form of a  
printed bar code. The most common UPC numbering system incorporates a 5-digit manu-  
30 facturer number and a 5-digit item number. Because of its limited precision, a UPC is used to

identify a class of product rather than an individual product item. The Uniform Code Council and EAN International define and administer the UPC and related codes as subsets of the 14-digit Global Trade Item Number (GTIN).

5        Within supply chain management, there is considerable interest in expanding or replacing the UPC scheme to allow individual product items to be uniquely identified and thereby tracked. Individual item tagging can reduce “shrinkage” due to lost, stolen or spoiled goods, improve the efficiency of demand-driven manufacturing and supply, facilitate the profiling of product usage, and improve the customer experience.

10        There are two main contenders for individual item tagging: optical tags in the form of so-called two-dimensional bar codes, and radio frequency identification (RFID) tags. For a detailed description of RFID tags, refer to Klaus Finkenzeller, *RFID Handbook*, John Wiley & Son (1999), the contents of which are herein incorporated by cross-reference. Optical tags have the advantage of being inexpensive, but require optical line-of-sight for reading. RFID tags have the advantage of supporting omnidirectional reading, but are comparatively expensive.

15        The presence of metal or liquid can seriously interfere with RFID tag performance, undermining the omnidirectional reading advantage. Passive (reader-powered) RFID tags are projected to be priced at 10 cents each in multi-million quantities by the end of 2003, and at 5 cents each soon thereafter, but this still falls short of the sub-one-cent industry target for low-price items such as grocery. The read-only nature of most optical tags has also been cited as a

20        disadvantage, since status changes cannot be written to a tag as an item progresses through the supply chain. However, this disadvantage is mitigated by the fact that a read-only tag can refer to information maintained dynamically on a network.

25        The Massachusetts Institute of Technology (MIT) Auto-ID Center has developed a standard for a 96-bit Electronic Product Code (EPC), coupled with an Internet-based Object Name Service (ONS) and a Product Markup Language (PML). Once an EPC is scanned or otherwise obtained, it is used to look up, possibly via the ONS, matching product information portably encoded in PML. The EPC consists of an 8-bit header, a 28-bit EPC manager, a 24-bit object class, and a 36-bit serial number. For a detailed description of the EPC, refer to Brock, D.L., *The Electronic Product Code (EPC)*, MIT Auto-ID Center (January 2001), the contents

30        of which are herein incorporated by cross-reference. The Auto-ID Center has defined a mapping of the GTIN onto the EPC to demonstrate compatibility between the EPC and current

practices Brock, D.L., *Integrating the Electronic Product Code (EPC) and the Global Trade Item Number (GTIN)*, MIT Auto-ID Center (November 2001), the contents of which are herein incorporated by cross-reference. The EPC is administered by EPCglobal, an EAN-UCC joint venture.

5 EPCs are technology-neutral and can be encoded and carried in many forms. The Auto-ID Center strongly advocates the use of low-cost passive RFID tags to carry EPCs, and has defined a 64-bit version of the EPC to allow the cost of RFID tags to be minimized in the short term. For detailed description of low-cost RFID tag characteristics, refer to Sarma, S., *Towards the 5c Tag*, MIT Auto-ID Center (November 2001), the contents of which are herein  
10 incorporated by cross-reference. For a description of a commercially-available low-cost passive RFID tag, refer to *915 MHz RFID Tag*, Alien Technology (2002), the contents of which are herein incorporated by cross-reference. For detailed description of the 64-bit EPC, refer to Brock, D.L., *The Compact Electronic Product Code*, MIT Auto-ID Center (November 2001), the contents of which are herein incorporated by cross-reference.

15 EPCs are intended not just for unique item-level tagging and tracking, but also for case-level and pallet-level tagging, and for tagging of other logistic units of shipping and transportation such as containers and trucks. The distributed PML database records dynamic relationships between items and higher-level containers in the packaging, shipping and transportation hierarchy.

20

#### **4.1 OMNITAGGING IN THE SUPPLY CHAIN**

Using an invisible (e.g. infrared) tagging scheme to uniquely identify a product item has the significant advantage that it allows the entire surface of a product to be tagged, or a significant portion thereof, without impinging on the graphic design of the product's packaging  
25 or labelling. If the entire product surface is tagged, then the orientation of the product doesn't affect its ability to be scanned, i.e. a significant part of the line-of-sight disadvantage of a visible bar code is eliminated. Furthermore, since the tags are small and massively replicated, label damage no longer prevents scanning.

30 Omnitagging, then, consists of covering a large proportion of the surface of a product item with optically-readable invisible tags. Each omnitag uniquely identifies the product item on which it appears. The omnitag may directly encode the product code (e.g. EPC) of the item,

or may encode a surrogate ID which in turn identifies the product code via a database lookup. Each omnitag also optionally identifies its own position on the surface of the product item, to provide the downstream consumer benefits of netpage interactivity described earlier.

5 Omnitags are applied during product manufacture and/or packaging using digital printers. These may be add-on infrared printers which print the omnitags after the text and graphics have been printed by other means, or integrated color and infrared printers which print the omnitags, text and graphics simultaneously. Digitally-printed text and graphics may include everything on the label or packaging, or may consist only of the variable portions, with other portions still printed by other means.

#### 10 **4.2 OMNITAGGING**

As shown in Figure 13, a product's unique item ID 215 may be seen as a special kind of unique object ID 210. The Electronic Product Code (EPC) 220 is one emerging standard for an item ID. An item ID typically consists of a product ID 214 and a serial number 213. The product ID identifies a class of product, while the serial number identifies a particular instance of that class, i.e. an individual product item. The product ID in turn typically consists of a manufacturer number 211 and a product class number 212. The best-known product ID is the EAN.UCC Universal Product Code (UPC) 221 and its variants.

20 As shown in Figure 14, an omnitag 202 encodes a page ID (or region ID) 50 and a two-dimensional (2D) position 86. The region ID identifies the surface region containing the tag, and the position identifies the tag's position within the two-dimensional region. Since the surface in question is the surface of a physical product item 201, it is useful to define a one-to-one mapping between the region ID and the unique object ID 210, and more specifically the item ID 215, of the product item. Note, however, that the mapping can be many-to-one without compromising the utility of the omnitag. For example, each panel of a product item's packaging could have a different region ID 50. Conversely, the omnitag may directly encode the item ID, in which case the region ID contains the item ID, suitably prefixed to decouple item ID allocation from general netpage region ID allocation. Note that the region ID uniquely distinguishes the corresponding surface region from all other surface regions identified within the global netpage system.

30 The item ID 215 is preferably the EPC 220 proposed by the Auto-ID Center, since this provides direct compatibility between omnitags and EPC-carrying RFID tags.

In Figure 14 the position 86 is shown as optional. This is to indicate that much of the utility of the omnitag in the supply chain derives from the region ID 50, and the position may be omitted if not desired for a particular product.

For interoperability with the netpage system, an omnitag 202 is a netpage tag 4, i.e. it has the logical structure, physical layout and semantics of a netpage tag.

When a netpage sensing device such as the netpage pen 101 images and decodes an omnitag, it uses the position and orientation of the tag in its field of view and combines this with the position encoded in the tag to compute its own position relative to the tag. As the sensing device is moved relative to a Hyperlabelled surface region, it is thereby able to track its own motion relative to the region and generate a set of timestamped position samples representative of its time-varying path. When the sensing device is a pen, then the path consists of a sequence of strokes, with each stroke starting when the pen makes contact with the surface, and ending when the pen breaks contact with the surface.

When a stroke is forwarded to the page server 10 responsible for the region ID, the server retrieves a description of the region keyed by region ID, and interprets the stroke in relation to the description. For example, if the description includes a hyperlink and the stroke intersects the zone of the hyperlink, then the server may interpret the stroke as a designation of the hyperlink and activate the hyperlink.

#### **4.3 OMNITAG PRINTING**

An omnitag printer is a digital printer which prints omnitags onto the label, packaging or actual surface of a product before, during or after product manufacture and/or assembly. It is a special case of a netpage printer 601. It is capable of printing a continuous pattern of omnitags onto a surface, typically using a near-infrared-absorptive ink. In high-speed environments, the printer includes hardware which accelerates tag rendering. This typically includes real-time Reed-Solomon encoding of variable tag data such as tag position, and real-time template-based rendering of the actual tag pattern at the dot resolution of the printhead.

The printer may be an add-on infrared printer which prints the omnitags after text and graphics have been printed by other means, or an integrated color and infrared printer which prints the omnitags, text and graphics simultaneously. Digitally-printed text and graphics may include everything on the label or packaging, or may consist only of the variable portions, with other portions still printed by other means. Thus an omnitag printer with an infrared and black



printing capability can displace an existing digital printer used for variable data printing, such as a conventional thermal transfer or inkjet printer.

For the purposes of the following discussion, any reference to printing onto an item label is intended to include printing onto the item packaging in general, or directly onto the item surface. Furthermore, any reference to an item ID 215 is intended to include a region ID 50 (or collection of per-panel region ids), or a component thereof.

The printer is typically controlled by a host computer, which supplies the printer with fixed and/or variable text and graphics as well as item ids for inclusion in the omnitags. The host may provide real-time control over the printer, whereby it provides the printer with data in real time as printing proceeds. As an optimisation, the host may provide the printer with fixed data before printing begins, and only provide variable data in real time. The printer may also be capable of generating per-item variable data based on parameters provided by the host. For example, the host may provide the printer with a base item ID prior to printing, and the printer may simply increment the base item ID to generate successive item ids. Alternatively, memory in the ink cartridge or other storage medium inserted into the printer may provide a source of unique item ids, in which case the printer reports the assignment of items ids to the host computer for recording by the host.

Alternatively still, the printer may be capable of reading a pre-existing item ID from the label onto which the omnitags are being printed, assuming the unique ID has been applied in some form to the label during a previous manufacturing step. For example, the item ID may already be present in the form of a visible 2D bar code, or encoded in an RFID tag. In the former case the printer can include an optical bar code scanner. In the latter case it can include an RFID reader.

The printer may also be capable of rendering the item ID in other forms. For example, it may be capable of printing the item ID in the form of a 2D bar code, or of printing the product ID component of the item ID in the form of a 1D bar code, or of writing the item ID to a writable or write-once RFID tag.

#### **4.4 OMNITAG SCANNING**

Item information typically flows to the product server in response to situated scan events, e.g. when an item is scanned into inventory on delivery; when the item is placed on a retail shelf; and when the item is scanned at point of sale. Both fixed and hand-held scanners

may be used to scan omnitagged product items, using both laser-based 2D scanning and 2D image-sensor-based scanning, using similar or the same techniques as employed in the netpage pen.

As shown in Figure 16, both a fixed scanner 254 and a hand-held scanner 252 communicate scan data to the product server 251. The product server may in turn communicate product item event data to a peer product server (not shown), or to a product application server 250, which may implement sharing of data with related product servers. For example, stock movements within a retail store may be recorded locally on the retail store's product server, but the manufacturer's product server may be notified once a product item is sold.

#### 10 **4.5 OMNITAG-BASED NETPAGE INTERACTIONS**

A product item whose labelling, packaging or actual surface has been omnitagged provides the same level of interactivity as any other netpage.

There is a strong case to be made for netpage-compatible product tagging. Netpage turns any printed surface into a finely differentiated graphical user interface akin to a Web page, and there are many applications which map nicely onto the surface of a product. These applications include obtaining product information of various kinds (nutritional information; cooking instructions; recipes; related products; use-by dates; servicing instructions; recall notices); playing games; entering competitions; managing ownership (registration; query, such as in the case of stolen goods; transfer); providing product feedback; messaging; and indirect device control. If, on the other hand, the product tagging is undifferentiated, such as in the case of an undifferentiated 2D barcode or RFID-carried item ID, then the burden of information navigation is transferred to the information delivery device, which may significantly increase the complexity of the user experience or the required sophistication of the delivery device user interface.

25 The invention will now be described with reference to the following examples. However, it will of course be appreciated that this invention may be embodied in many other forms without departing from the scope of the invention, as defined in the accompanying claims.

#### 30 Examples

In the following examples, uv-visible spectra are reported conventionally by stating an absorption wavelength first, followed by the corresponding  $\log \epsilon_{\max}$  in parentheses. For example, "760 (5.11)" denotes an absorption at 760 nm having a  $\log \epsilon_{\max}$  of 5.11.

### 5 **Example 1**

#### *Nickel dithiolene camphorsulfonic acid dipotassium salt*

Phosphorous pentasulfide (12.5 g; 0.028 mol) was added to a solution of camphorquinone-sulfonic acid mono-hydrate (5.1 g; 0.019 mol) in freshly distilled dioxane (150 mL). The resulting mixture was heated under reflux for 2 h under a nitrogen atmosphere. After this time  
10 the reaction mixture was cooled slightly and while still quite warm was filtered through a sintered glass funnel to remove unreacted  $P_4S_{10}$ . Nickel chloride hexahydrate (8.2 g; 0.034 mol) in water (100 mL) was added to the filtrate and the resulting mixture was heated under reflux for a further 2 h. During this time the colour changed from green/beige to black. The reaction mixture was consecutively cooled, diluted with water (200 mL), treated with  
15 tetrabutylammonium hydroxide (40%, 50 mL) and extracted with dichloromethane ( $3 \times 250$  mL). The dichloromethane was removed by evaporation and the residue was dissolved in ethanol (500 mL). The ethanol solution was percolated through a sintered glass funnel containing DOWEX- $H^+$  resin, washing with more ethanol, in order to convert the tetrabutylammonium salt into the free acid. The black ethanol solution was treated with  
20 potassium *tert*-butoxide (2 g; 0.018 mol) in ethanol (50 mL) with stirring. The resulting cloudy brown mixture was filtered, washing consecutively with ethanol, warm ethanol, warm ether, and finally warm acetone to give the nickel dithiolene dipotassium salt as a dark purple solid (3.14 g; 44%).  $\lambda_{\max}$  781 (4.11), 541 (2.95); MS (ESI)  $m/z$ : 651 [(M-K) $^+$ ], 27%, 306 [(M-2K) $^{2-}$ , 100]; HRMS:  $m/z$  calcd for  $C_{20}H_{26}NiO_6S_6^{2-}$  (M $^+$ -2K) $^{2-}$  305.9708, found 305.9711.

25

### **Example 2**

#### *Nickel dithiolene camphorsulfonic acid disodium salt*

A mixture of camphorquinonesulfonic acid mono-hydrate (4.12 g, 0.016 mol) and phosphorous pentasulfide (10.3 g, 0.023 mol) in dioxane (100 mL) was heated at reflux for 2 h. The excess  
30 phosphorous pentasulfide was filtered off and washed with dioxane (50 mL). A solution of nickel (II) chloride hexahydrate (8.10 g, 0.034 mol) in water (50 mL) was added to the dioxane

solution and the black reaction mixture heated at reflux for 2 h. The resulting dark-magenta solution was diluted with water (500 mL), filtered and extracted with chloroform (2 x 200 mL). The aqueous layer was basified to pH 8 with tetrabutylammonium hydroxide (40%, 60 mL) and extracted with chloroform (3 x 200 mL). The combined organic layers were washed with water (1 x 200 mL) and the solvent removed under reduced pressure. The tetrabutylammonium salt was dissolved in ethanol and eluted through a column of DOWEX-H<sup>+</sup> resin to give the free acid. This ethanol solution was then eluted through a column of Amberlite IRP-64 resin (Na<sup>+</sup> form) and the solvent removed to give the sodium salt as a dark-purple powder.  $\lambda_{\max}$  783 nm; (ESI)  $m/z$ : 635 [(M-Na)<sup>+</sup>, 27%), 306 [(M-2Na)<sup>2+</sup>, 100]; HRMS:  $m/z$  calcd for C<sub>20</sub>H<sub>26</sub>NiO<sub>6</sub>S<sub>6</sub><sup>2-</sup> (M<sup>+</sup>-2Na)<sup>2-</sup> 305.9708, found 305.9723.

### Example 3

#### *Palladium dithiolene camphorsulfonic acid dipotassium salt*

Phosphorous pentasulfide (1.97 g; 4.4 mmol) was added to a solution of camphorquinone-sulfonic acid mono-hydrate (0.59 g; 2.2 mmol) in freshly distilled dioxane (30 mL). The reaction mixture was heated under reflux for 2 h and filtered. The filtrate was treated with palladium (II) acetate (0.25 g; 1.1 mmol) in water (10 mL) with stirring causing the reaction mixture to become cloudy and then dark purple in colour. The whole was heated under reflux for 2 h and diluted with water (300 mL). Tetrabutylammonium hydroxide solution (40%, 5 mL) was added and then the mixture was extracted with chloroform (3 x 100 mL). The solvent was removed by evaporation and the purple residue was dissolved in ethanol (50 mL) before percolating through a DOWEX-H<sup>+</sup> column. The DOWEX was washed with ethanol until colourless (150 mL). The resulting ethanol solution was treated with potassium *t*-butoxide (1 g; 8.9 mmol) and cooled causing a purple solid to separate out. The solid was filtered, washed with ethanol (100 mL), and dried thereby affording the palladium complex as a purple solid (0.382 g; 50%).  $\lambda_{\max}$  831 nm.

### Example 4

#### *Stability of dye from Example 1 with and without singlet oxygen quenchers*

Paper samples with nickel dithiolene camphorsulfonic acid dipotassium salt from Example 1 ("CSA") and antioxidants were placed under a sunlamp and their reflectance

spectra recorded over time. The relative rates of decomposition were calculate and plotted over time (Figure 19). CSA with ascorbic acid and sodium azide show a retarded rate of decomposition compared with CSA without any antioxidant present.

5           Throughout this specification and the claims which follow, unless the context requires otherwise, the word "comprise", and variations such as "comprises" or "comprising", will be understood to imply the inclusion of a stated integer or step or group of integers or steps but not the exclusion of any other integer or step or group of integers or steps.

10

          The reference in this specification to any prior publication (or information derived from it), or to any matter which is known, is not, and should not be taken as, an acknowledgement or admission or any form of suggestion that that prior publication (or information derived from it) or known matter forms part of the common general

15 knowledge in the field of endeavour to which this specification relates.

04 May 2007

2004228065

CLAIMS:

1. An IR-absorbing dye suitable for formulating a water-based inkjet ink, said dye being of formula (011):

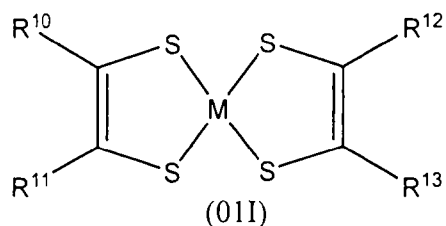

5 wherein:

M is selected from Ni, Pd or Pt;

R<sup>10</sup> and R<sup>11</sup> are independently selected from C<sub>1-30</sub> hydrocarbyl, or R<sup>10</sup> and R<sup>11</sup> together are joined to form a C<sub>2-30</sub> hydrocarbylene group;

10 R<sup>12</sup> and R<sup>13</sup> are independently selected from C<sub>1-30</sub> hydrocarbyl, or R<sup>12</sup> and R<sup>13</sup> together are joined to form a C<sub>2-30</sub> hydrocarbylene group;

wherein at least one of R<sup>10</sup>, R<sup>11</sup>, R<sup>12</sup> or R<sup>13</sup> comprises a hydrophilic group selected from the group consisting of an ammonium group; an acid group, including salts thereof; or a sulfonamide group.

15 2. The dye of claim 1, wherein said hydrophilic group is of formula -CO<sub>2</sub>Z, -SO<sub>3</sub>Z, -OSO<sub>3</sub>Z, -PO<sub>3</sub>Z<sub>2</sub> or -OPO<sub>3</sub>Z<sub>2</sub>, wherein Z is H or a water-soluble cation.

3. The dye of claim 2, wherein Z is selected from Li<sup>+</sup>, Na<sup>+</sup> or K<sup>+</sup>.

4. The dye of claim 1, wherein said hydrophilic group is a sulfonic acid group or a metal salt thereof.

5. The dye of claim 2, wherein said hydrophilic group is -SO<sub>3</sub>Na or -SO<sub>3</sub>K.

20 6. The dye of claim 1, wherein at least one of R<sup>10</sup>, R<sup>11</sup>, R<sup>12</sup> or R<sup>13</sup> comprises a moiety suitable for reducing intermolecular interactions.

7. The dye of claim 6, wherein said moiety suitable for reducing intermolecular interactions is a polymer.

8. The dye of claim 6, wherein said moiety suitable for reducing intermolecular interactions is a bridged cyclic group.

9. The dye of claim 8, wherein  $R^{10}$  and  $R^{11}$  together are joined to form a bridged cyclic group.

5 10. The dye of claim 8, wherein  $R^{12}$  and  $R^{13}$  together are joined to form a bridged cyclic group.

11. The dye of claim 1, wherein M is Ni.

12. An IR-absorbing dye according to claim 1, said dye being of formula (01II):

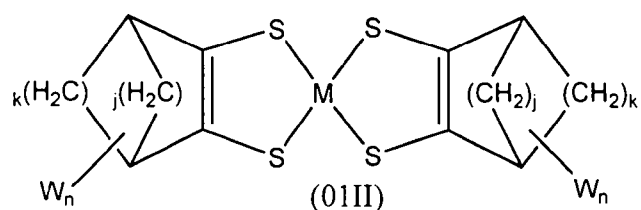

10 wherein:

M is selected from Ni, Pd or Pt;

j is selected from 0, 1, 2, 3 or 4;

k is selected from 0, 1, 2, 3 or 4;

n is selected from 1, 2 or 3;

15 W is a hydrophilic group;

up to three  $-(CH_2)-$  groups in the carbocycle may be optionally replaced by a group independently selected from  $-C(O)-$ ,  $-NH-$ ,  $-S-$ ,  $-O-$ ;

up to three  $-CH-$  groups in the carbocycle may be optionally replaced by  $-N-$ ;

up to four H atoms in the carbocycle may be optionally replaced by a group

20 independently selected from  $C_{1-6}$  alkyl,  $C_{1-6}$  alkoxy,  $C_{5-12}$  aryl,  $C_{5-12}$  arylalkyl, halogen, hydroxyl or amino; and

provided that at least one of j or k is greater than 0.

13. The dye of claim 12, wherein M is Ni.

14. The dye of claim 12, wherein j is 1 and k is 2.

15. The dye of claim 14 comprising a  $-C(C_{1-4} \text{ alkyl})_2-$  bridging group.
16. The dye of claim 12, wherein n is 1.
17. The dye of claim 12, wherein W is selected from a substituent comprising a PEG chain; a substituent comprising an ammonium group; a substituent comprising an acid group, including salts thereof; or a substituent comprising a sulfonamide group.  
5
18. The dye of claim 12, wherein W is a substituent comprising a group of formula  $-CO_2Z$ ,  $-SO_3Z$ ,  $-OSO_3Z$ ,  $-PO_3Z_2$  or  $-OPO_3Z_2$ , wherein Z is H or a water-soluble cation.
19. The dye of claim 12, wherein W is of formula  $-(CH_2)_t-SO_3Z$ , wherein t is 0  
10 or an integer from 1 to 6, and Z is H or a water-soluble cation.
20. The dye of claim 12, wherein W is of formula  $-CH_2SO_3H$ ,  $-CH_2SO_3Na$  or  $-CH_2SO_3K$ .
21. An inkjet ink comprising a dye according to claim 1.
22. An inkjet printer comprising a printhead in fluid communication with at  
15 least one ink reservoir, wherein said at least one ink reservoir comprises an inkjet ink according to claim 21.
23. The inkjet printer of claim 22, wherein said printhead comprises:  
a plurality of nozzles;  
a bubble forming chamber corresponding to each of the nozzles respectively, the  
20 bubble forming chambers adapted to contain ejectable liquid; and  
a heater element disposed in each of the bubble forming chambers respectively, the heater element configured for thermal contact with the ejectable liquid; such that,  
heating the heater element to a temperature above the boiling point of the ejectable liquid forms a gas bubble that causes the ejection of a drop of the ejectable liquid from the  
25 nozzle; wherein,  
the heater element is suspended in the ink chamber such that during use at least a portion of the heater element is encircled by, and in direct contact with, the ejectable fluid.



2004228065 21 Jun 2007

24. An ink cartridge for an inkjet printer, said ink cartridge comprising an inkjet ink according to claim 21.

25. The ink cartridge of claim 24, wherein said cartridge comprises:  
a housing defining a plurality of storage areas wherein at least one of the  
5 storage areas contains colorant for printing information that is visible to the human eye and  
at least one of the other storage areas contains an inkjet ink according to claim 21.

26. A substrate having a dye according to claim 1 disposed thereon.

27. The substrate of claim 26, wherein said dye is disposed in the form of coded  
data.

10 28. The substrate of claim 27 comprising an interface surface and wherein the  
coded data is disposed over a substantial portion of said interface surface.

29. The substrate of claim 28, which is a paper sheet, a label, a tag, a packaging  
material or a product item.

30. A method of enabling entry of data into a computer system via a printed  
15 form, the form containing human-readable information and machine-readable coded data,  
the coded data being indicative of an identity of the form and of a plurality of reference  
points of the form, the method including the steps of:

receiving, in the computer system and from a sensing device, indicating  
data regarding the identity of the form and a position of the sensing device relative to the  
20 form, the sensing device, when placed in an operative position relative to the form,  
generating the indicating data using at least some of the coded data;

identifying, in the computer system and from the indicating data, at least  
one field of the form; and

25 interpreting, in the computer system, at least some of the indicating data as  
it relates to the at least one field,

wherein said coded data comprises an IR-absorbing dye according to claim 1.

31. The method of claim 30 in which the at least one field is associated with at  
least one zone of the form, the identifying step including identifying that the position of the  
sensing device is within the at least one zone.

32. The method of claim 31 in which the indicating data includes movement data regarding movement of the sensing device relative to the form, the sensing device generating the movement data using at least some of the coded data, the identifying step including identifying that the movement of the sensing device is at least partially within the  
5 at least one zone.

33. A method of enabling entry of data into a computer system via a printed form, the form containing human-readable information and machine-readable coded data, the coded data being indicative of at least one field of the form, the method including the steps of:

10 receiving, in the computer system and from a sensing device, indicating data regarding the at least one field and including movement data regarding movement of the sensing device relative to the form, the sensing device, when moved relative to the form, generating the data regarding said at least one field using at least some of the coded data and generating the data regarding its own movement relative to the form; and

15 interpreting, in the computer system, at least some of said indicating data as it relates to said at least one field,

wherein said coded data comprises an IR-absorbing dye according to claim 1.

34. The method of claim 33 in which the sensing device generates the movement data using at least some of the coded data.

20 35. The method of any one of claims 31, 32 or 33 in which the at least one field is a text field and the interpreting step includes converting at least some of the movement data to text.

36. The method of any one of claims 31, 32 or 33 in which the at least one field is a drawing field.

25 37. The method of any one of claims 31, 32 or 33 in which the at least one field is a checkbox field and the interpreting step includes interpreting at least some of the movement data as a check mark.

38. The method of any one of claims 31, 32 or 33 in which the at least one field is a signature field and the interpreting step includes verifying that at least some of the movement data represents a signature of a user associated with the sensing device.

39. The method of claim 30 or claim 33 in which the at least one field is an  
5 action field and the interpreting step includes sending a message to an application associated with the action field.

40. The method of claim 39 in which the action field is a form submission action field and the message includes form data derived from at least one other field of the form.

10 41. A method of enabling entry of data into a computer system via a product item, the product item having a printed surface containing human-readable information and machine-readable coded data, the coded data being indicative of an identity of the product item, the method including the steps of:

(a) receiving, in the computer system and from a sensing device, indicating  
15 data regarding the identity of the product item, the sensing device, when placed in an operative position relative to the product item, generating the indicating data using at least some of the coded data; and

(b) recording, in the computer system and using the indicating data, information  
relating to the product item,  
20 wherein said coded data comprises an IR-absorbing dye according to claim 1.

42. A method of enabling retrieval of data from a computer system via a product item, the product item having a printed surface containing human-readable information and machine-readable coded data, the coded data being indicative of an identity of the product item, the method including the steps of:

25 (a) receiving, in the computer system and from a sensing device, indicating data regarding the identity of the product item, the sensing device, when placed in an operative position relative to the product item, generating the indicating data using at least some of the coded data;

(b) retrieving, in the computer system and using the indicating data,  
30 information relating to the product item; and

(c) outputting, from the computer system and to an output device, the information relating to the product item, the output device selected from the group comprising a display device and a printing device,

wherein said coded data comprises an IR-absorbing dye according to claim 1.

5 43. The method of claim 41 or 42 in which the coded data is formed from a plurality of coded data portions, each coded data portion being indicative of the identity of the product item.

44. The method of claim 41 or 42 in which the coded data is indicative of at least one of a UPC and an EPC associated with the product item.

10 45. The method of claim 32 or 35 in which the form is disposed on a surface of a product item and in which the coded data is indicative of an identity of the product item.

46. The method of claim 45 in which the coded data is formed from a plurality of coded data portions, each coded data portion being indicative of the identity of the product item.

15 47. The method of claim 45 in which the coded data is indicative of at least one of a UPC and an EPC associated with the product item.

48. The method of any one of claims 30, 33, 41 or 42 in which the coded data is substantially invisible to an unaided human eye.

20 49. A stabilized ink composition comprising an IR-absorbing metal-dithiolene dye according to claim 1, and a singlet oxygen quencher.

50. The ink composition of claim 49, wherein said IR-absorbing metal-dithiolene dye is preselected to minimize visible absorption by reducing cofacial interactions between adjacent dye molecules.

51. The ink composition of claim 49, which is a water-based inkjet ink.

25 52. The ink composition of claim 49, wherein the singlet oxygen quencher is selected from ascorbic acid, 1,4-diazabicyclo-[2.2.2]octane (DABCO), sodium azide, histidine or tryptophan.

53. The ink composition of claim 49, wherein at least one of  $R^{10}$ ,  $R^{11}$ ,  $R^{12}$  or  $R^{13}$  comprises a moiety suitable for reducing cofacial interactions.

54. The ink composition of claim 53, wherein said moiety suitable for reducing cofacial interactions is a bridged cyclic group.

5 55. The ink composition of claim 53, wherein the moiety for reducing cofacial interactions is a polymeric group.

56. The ink composition of claim 55, wherein the polymeric group is a dendrimer.

57. The ink composition of claim 55, wherein the polymeric group includes a  
10 PEG chain.

58. The IR-absorbing dye of claim 1, wherein the metal-dithiolene dye is of formula (02II):

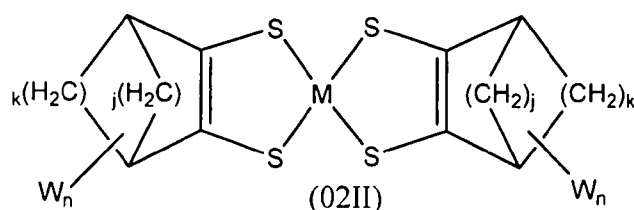

wherein:

15 M is selected from Ni, Pd or Pt;

j is selected from 0, 1, 2, 3 or 4;

k is selected from 0, 1, 2, 3 or 4;

n is selected from 0, 1, 2 or 3;

W is a hydrophilic group;

20 up to three  $-(CH_2)-$  groups in the carbocycle may be optionally replaced by a group independently selected from  $-C(O)-$ ,  $-NH-$ ,  $-S-$ ,  $-O-$ ;

up to three  $-CH-$  groups in the carbocycle may be optionally replaced by  $-N-$ ;

up to four H atoms in the carbocycle may be optionally replaced by a group independently selected from  $C_{1-6}$  alkyl,  $C_{1-6}$  alkoxy,  $C_{5-12}$  aryl,  $C_{5-12}$  arylalkyl, halogen,  
25 hydroxyl or amino; and

provided that at least one of j or k is greater than 0.

59. The IR-absorbing dye of claim 58, wherein M is Ni.
60. The IR-absorbing dye of claim 58, wherein j is 1 and k is 2.
61. The IR-absorbing dye of claim 58 comprising a  $-(C_{1-4} \text{ alkyl})_2-$  bridging group.
- 5 62. The IR-absorbing dye of claim 58, wherein n is 1.
63. The IR-absorbing dye of claim 58, wherein W is selected from a substituent comprising a PEG chain; a substituent comprising an ammonium group; a substituent comprising an acid group, including salts thereof; or a substituent comprising a sulfonamide group.
- 10 64. The IR-absorbing dye of claim 58, wherein W is of formula  $-(CH_2)_t-SO_3Z$ , wherein t is 0 or an integer from 1 to 6, and Z is H or a water-soluble cation.
65. The IR-absorbing dye of claim 58, wherein W is of formula  $-CH_2SO_3H$ ,  $-CH_2SO_3Na$  or  $-CH_2SO_3K$ .
66. An inkjet printer comprising a printhead in fluid communication with at  
15 least one ink reservoir, wherein said at least one ink reservoir comprises an inkjet ink according to claim 51.
67. The inkjet printer of claim 66, wherein said printhead comprises:  
a plurality of nozzles;  
a bubble forming chamber corresponding to each of the nozzles respectively, the  
20 bubble forming chambers adapted to contain ejectable liquid; and  
a heater element disposed in each of the bubble forming chambers respectively, the heater element configured for thermal contact with the ejectable liquid; such that,  
heating the heater element to a temperature above the boiling point of the ejectable liquid forms a gas bubble that causes the ejection of a drop of the ejectable liquid from the  
25 nozzle; wherein,  
the heater element is suspended in the ink chamber such that during use at least a portion of the heater element is encircled by, and in direct contact with, the ejectable fluid.

2004228065 21 Jun 2007

68. An ink cartridge for an inkjet printer, said ink cartridge comprising an inkjet ink according to claim 51.

69. The ink cartridge of claim 68, wherein said cartridge is replaceable.

70. The ink cartridge of claim 68, wherein said cartridge comprises:

5 a housing defining a plurality of storage areas wherein at least one of the storage areas contains colorant for printing information that is visible to the human eye and at least one of the other storage areas contains an inkjet ink according to claim 21.

71. The ink cartridge of claim 70, wherein each storage area is sized corresponding to the expected levels of use of its contents relative to the intended print  
10 coverage for a number of printed pages.

72. A substrate having an ink composition according to claim 49 disposed thereon.

73. The substrate of claim 72, wherein said ink composition is disposed in the form of coded data.

15 74. The substrate of claim 73 comprising an interface surface and wherein the coded data is disposed over a substantial portion of said interface surface.

75. The substrate of claim 72, which is a paper sheet, a label, a tag, a packaging material or a product item.

20 76. A method of enabling entry of data into a computer system via a printed form, the form containing human-readable information and machine-readable coded data, the coded data being indicative of an identity of the form and of a plurality of reference points of the form, the method including the steps of:

receiving, in the computer system and from a sensing device, indicating data regarding the identity of the form and a position of the sensing device relative to the form,  
25 the sensing device, when placed in an operative position relative to the form, generating the indicating data using at least some of the coded data;

identifying, in the computer system and from the indicating data, at least one field of the form; and

interpreting, in the computer system, at least some of the indicating data as it relates to the at least one field,

wherein said coded data comprises an ink composition according to claim 49.

77. The method of claim 76 in which the at least one field is associated with at least one zone of the form, the identifying step including identifying that the position of the sensing device is within the at least one zone.

78. The method of claim 77 in which the indicating data includes movement data regarding movement of the sensing device relative to the form, the sensing device generating the movement data using at least some of the coded data, the identifying step including identifying that the movement of the sensing device is at least partially within the at least one zone.

79. A method of enabling entry of data into a computer system via a printed form, the form containing human-readable information and machine-readable coded data, the coded data being indicative of at least one field of the form, the method including the steps of:

receiving, in the computer system and from a sensing device, indicating data regarding the at least one field and including movement data regarding movement of the sensing device relative to the form, the sensing device, when moved relative to the form, generating the data regarding said at least one field using at least some of the coded data and generating the data regarding its own movement relative to the form; and

interpreting, in the computer system, at least some of said indicating data as it relates to said at least one field,

wherein said coded data comprises an ink composition according to claim 49.

80. The method of claim 79 in which the sensing device generates the movement data using at least some of the coded data.

81. The method of any one of claims 77, 78 or 79 in which the at least one field is a text field and the interpreting step includes converting at least some of the movement data to text.

82. The method of any one of claims 77, 78 or 79 in which the at least one field is a drawing field.



83. The method of any one of claims 77, 78 or 79 in which the at least one field is a checkbox field and the interpreting step includes interpreting at least some of the movement data as a check mark.

5 84. The method of any one of claims 77, 78 or 79 in which the at least one field is a signature field and the interpreting step includes verifying that at least some of the movement data represents a signature of a user associated with the sensing device.

85. The method of claim 76 or claim 79 in which the at least one field is an action field and the interpreting step includes sending a message to an application associated with the action field.

10 86. The method of claim 85 in which the action field is a form submission action field and the message includes form data derived from at least one other field of the form.

15 87. A method of enabling entry of data into a computer system via a product item, the product item having a printed surface containing human-readable information and machine-readable coded data, the coded data being indicative of an identity of the product item, the method including the steps of:

20 (a) receiving, in the computer system and from a sensing device, indicating data regarding the identity of the product item, the sensing device, when placed in an operative position relative to the product item, generating the indicating data using at least some of the coded data; and

(b) recording, in the computer system and using the indicating data, information relating to the product item,

wherein said coded data comprises an ink composition according to claim 49.

25 88. A method of enabling retrieval of data from a computer system via a product item, the product item having a printed surface containing human-readable information and machine-readable coded data, the coded data being indicative of an identity of the product item, the method including the steps of:

(a) receiving, in the computer system and from a sensing device, indicating data regarding the identity of the product item, the sensing device, when placed in an

2004228065 21 Jun 2007

operative position relative to the product item, generating the indicating data using at least some of the coded data;

(b) retrieving, in the computer system and using the indicating data, information relating to the product item; and

5 (c) outputting, from the computer system and to an output device, the information relating to the product item, the output device selected from the group comprising a display device and a printing device,

wherein said coded data comprises an ink composition according to claim 49.

89. The method of claim 87 or 88 in which the coded data is formed from a  
10 plurality of coded data portions, each coded data portion being indicative of the identity of the product item.

90. The method of claim 87 or 88 in which the coded data is indicative of at least one of a UPC and an EPC associated with the product item.

91. The method of claim 76 or 79 in which the form is disposed on a surface of  
15 a product item and in which the coded data is indicative of an identity of the product item.

92. The method of claim 91 in which the coded data is formed from a plurality of coded data portions, each coded data portion being indicative of the identity of the product item.

93. The method of claim 91 in which the coded data is indicative of at least one  
20 of a UPC and an EPC associated with the product item.

94. The method of any one of claims 76, 79, 87 or 88 in which the coded data is substantially invisible to an unaided human eye.

95. A method of minimizing absorption of visible light in an ink composition comprising an IR-absorbing metal-dithiolenene dye according to claim 1, comprising  
25 preselecting said dye such that it includes at least one moiety for reducing intermolecular interactions between adjacent dye molecules.

96. The method of claim 95, wherein the dye comprises a substantially planar  $\pi$ -system and the intermolecular interactions are  $\pi$ - $\pi$  interactions.

97. The method of claim 95, wherein the intermolecular interactions are reduced by steric repulsion.

98. The method of claim 96, wherein the dye molecule comprises at least one moiety, which extends out of the plane of the substantially planar  $\pi$ -system.

5 99. The method of claim 95, wherein the intermolecular interactions are reduced using a bridged cyclic group.

100. The method of claim 95, wherein the intermolecular interactions are reduced using a polymeric group.

101. The method of claim 100, wherein the polymeric group is a dendrimer.

10 102. The method of claim 100, wherein the polymeric group includes a PEG chain.

103. The method of claim 95, wherein the dye is preselected from a metal-dithiolene of formula (03I):

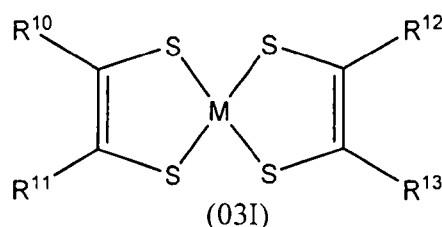

15 wherein:

M is selected from Ni, Pd or Pt;

$R^{10}$  and  $R^{11}$  are independently selected from  $C_{1-30}$  hydrocarbyl, or  $R^{10}$  and  $R^{11}$  together are joined to form a  $C_{1-30}$  hydrocarbylene group;

20  $R^{12}$  and  $R^{13}$  are independently selected from  $C_{1-30}$  hydrocarbyl, or  $R^{12}$  and  $R^{13}$  together are joined to form a  $C_{1-30}$  hydrocarbylene group;

wherein at least one of  $R^{10}$ ,  $R^{11}$ ,  $R^{12}$  or  $R^{13}$  comprises a moiety for reducing intermolecular interactions.

104. The method of claim 103, wherein the moiety suitable for reducing intermolecular interactions is a bridged cyclic group.

105. The method of claim 103, wherein R<sup>10</sup> and R<sup>11</sup> together are joined to form a bridged cyclic group.

106. The method of claim 103, wherein R<sup>12</sup> and R<sup>13</sup> together are joined to form a bridged cyclic group.

5 107. The method of claim 103, wherein the moiety for reducing intermolecular interactions is a polymeric group.

108. The method of claim 107, wherein the polymeric group is a dendrimer.

109. The method of claim 107, wherein the polymeric group includes a PEG chain.

10 110. The method of claim 103, wherein M is Ni.

111. The method of claim 103, wherein the dye is preselected from a metal-dithiolene of formula (03II):

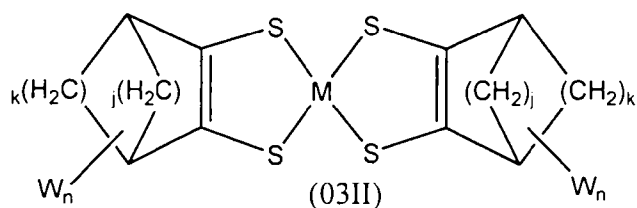

wherein:

15 M is selected from Ni, Pd or Pt (preferably Ni);

j is selected from 1, 2, 3 or 4;

k is selected from 1, 2, 3 or 4;

n is 0, 1, 2 or 3;

W is a hydrophilic group;

20 up to three  $-(CH_2)-$  groups in the carbocycle are optionally replaced by a group independently selected from  $-C(O)-$ ,  $-NH-$ ,  $-S-$ ,  $-O-$ ;

up to three  $-CH-$  groups in the carbocycle may be optionally replaced by  $-N-$ ; and

25 up to four H atoms in the carbocycle may be optionally replaced a group independently selected from C<sub>1-6</sub> alkyl, C<sub>1-6</sub> alkoxy, C<sub>5-12</sub> aryl, C<sub>5-12</sub> arylalkyl, halogen, hydroxyl or amino.

112. The method of claim 111, wherein M is Ni.
113. The method of claim 111, wherein j is 1 and k is 2.
114. The method of claim 111, wherein said dye comprises a  $-(C_{1-4} \text{ alkyl})_2-$  bridging group.
- 5 115. The method of claim 111, wherein n is 1.
116. The method of claim 111, wherein W is selected from a substituent comprising a PEG chain; a substituent comprising an ammonium group; a substituent comprising an acid group, including salts thereof; or a substituent comprising a sulfonamide group.
- 10 117. The method of claim 111, wherein W is a substituent comprising a group of formula  $-\text{CO}_2\text{Z}$ ,  $-\text{SO}_3\text{Z}$ ,  $-\text{OSO}_3\text{Z}$ ,  $-\text{PO}_3\text{Z}$  or  $-\text{OPO}_3\text{Z}$ , wherein Z is H or a water-soluble cation.
118. The method of claim 117, wherein W is of formula  $-(\text{CH}_2)_t-\text{SO}_3\text{Z}$ , wherein t is 0 or an integer from 1 to 6, and Z is H or a water-soluble cation.
- 15 119. The method of claim 117, wherein W is of formula  $-\text{CH}_2\text{SO}_3\text{H}$ ,  $-\text{CH}_2\text{SO}_3\text{Na}$  or  $-\text{CH}_2\text{SO}_3\text{K}$ .
120. The method of claim 95, wherein the ink is an inkjet ink.
121. The method of claim 120, wherein said inkjet ink further comprises a singlet oxygen quencher.
- 20 122. The method of claim 121, wherein said inkjet ink is contained in an ink reservoir in fluid communication with a printhead of an inkjet printer.
123. The method of claim 122, wherein said printhead comprises:  
a plurality of nozzles;  
a bubble forming chamber corresponding to each of the nozzles respectively, the  
25 bubble forming chambers adapted to contain ejectable liquid; and

2004228065 21 Jun 2007

a heater element disposed in each of the bubble forming chambers respectively, the heater element configured for thermal contact with the ejectable liquid; such that,

5 heating the heater element to a temperature above the boiling point of the ejectable liquid forms a gas bubble that causes the ejection of a drop of the ejectable liquid from the nozzle; wherein,

the heater element is suspended in the ink chamber such that during use at least a portion of the heater element is encircled by, and in direct contact with, the ejectable fluid.

10 124. The method of claim 121, wherein said inkjet ink is contained in an ink cartridge.

125. A method of minimizing visible coloration of a substrate having an IR-absorbing metal-dithiolene dye according to claim 1 disposed thereon, said method comprising preselecting said dye such that it includes a moiety for reducing intermolecular interactions between adjacent dye molecules.

15 126. The method of claim 125, wherein said dye is disposed in the form of coded data.

127. The method of claim 126, wherein said substrate comprises an interface surface and wherein the coded data is disposed over a substantial portion of said interface surface.

20 128. The method claim 125, wherein said substrate is a paper sheet, a label, a tag, a packaging material or a product item.

25 129. A method of enabling entry of data into a computer system via a printed form, the form containing human-readable information and machine-readable coded data, the coded data being indicative of an identity of the form and of a plurality of reference points of the form, the method including the steps of:

receiving, in the computer system and from a sensing device, indicating data regarding the identity of the form and a position of the sensing device relative to the form, the sensing device, when placed in an operative position relative to the form, generating the indicating data using at least some of the coded data;

2004228065 21 Jun 2007

identifying, in the computer system and from the indicating data, at least one field of the form; and

interpreting, in the computer system, at least some of the indicating data as it relates to the at least one field,

5 wherein said coded data comprises an ink composition in which visible absorption is minimized by a method according to claim 95 or 121.

130. The method of claim 129 in which the at least one field is associated with at least one zone of the form, the identifying step including identifying that the position of the sensing device is within the at least one zone.

10 131. The method of claim 130 in which the indicating data includes movement data regarding movement of the sensing device relative to the form, the sensing device generating the movement data using at least some of the coded data, the identifying step including identifying that the movement of the sensing device is at least partially within the at least one zone.

15 132. A method of enabling entry of data into a computer system via a printed form, the form containing human-readable information and machine-readable coded data, the coded data being indicative of at least one field of the form, the method including the steps of:

20 receiving, in the computer system and from a sensing device, indicating data regarding the at least one field and including movement data regarding movement of the sensing device relative to the form, the sensing device, when moved relative to the form, generating the data regarding said at least one field using at least some of the coded data and generating the data regarding its own movement relative to the form; and

25 interpreting, in the computer system, at least some of said indicating data as it relates to said at least one field,

wherein said coded data comprises an ink composition in which visible absorption is minimized by a method according to claim 95 or 121.

133. The method of claim 132 in which the sensing device generates the movement data using at least some of the coded data.

2004228065 21 Jun 2007

134. The method any one of claims 130, 131 or 132 in which the at least one field is a text field and the interpreting step includes converting at least some of the movement data to text.

5 135. The method any one of claims 130, 131 or 132 in which the at least one field is a drawing field.

136. The method any one of claims 130, 131 or 132 in which the at least one field is a checkbox field and the interpreting step includes interpreting at least some of the movement data as a check mark.

10 137. The method any one of claims 130, 131 or 132 in which the at least one field is a signature field and the interpreting step includes verifying that at least some of the movement data represents a signature of a user associated with the sensing device.

138. The method of claim 129 or claim 132 in which the at least one field is an action field and the interpreting step includes sending a message to an application associated with the action field.

15 139. The method of claim 138 in which the action field is a form submission action field and the message includes form data derived from at least one other field of the form.

20 140. A method of enabling entry of data into a computer system via a product item, the product item having a printed surface containing human-readable information and machine-readable coded data, the coded data being indicative of an identity of the product item, the method including the steps of:

25 (a) receiving, in the computer system and from a sensing device, indicating data regarding the identity of the product item, the sensing device, when placed in an operative position relative to the product item, generating the indicating data using at least some of the coded data; and

(b) recording, in the computer system and using the indicating data, information relating to the product item,

wherein said coded data comprises an ink composition in which visible absorption is minimized by a method according to claim 95 or 121.



141. A method of enabling retrieval of data from a computer system via a product item, the product item having a printed surface containing human-readable information and machine-readable coded data, the coded data being indicative of an identity of the product item, the method including the steps of:

5 (a) receiving, in the computer system and from a sensing device, indicating data regarding the identity of the product item, the sensing device, when placed in an operative position relative to the product item, generating the indicating data using at least some of the coded data;

(b) retrieving, in the computer system and using the indicating data,  
10 information relating to the product item; and

(c) outputting, from the computer system and to an output device, the information relating to the product item, the output device selected from the group comprising a display device and a printing device,

wherein said coded data comprises an ink composition in which visible absorption  
15 is minimized by a method according to claim 95 or 121.

142. The method of claim 140 or 141 in which the coded data is formed from a plurality of coded data portions, each coded data portion being indicative of the identity of the product item.

143. The method of claim 140 or 141 in which the coded data is indicative of at  
20 least one of a UPC and an EPC associated with the product item.

144. The method of claim 129 or 132 in which the form is disposed on a surface of a product item and in which the coded data is indicative of an identity of the product item.

145. The method of claim 144 in which the coded data is formed from a plurality  
25 of coded data portions, each coded data portion being indicative of the identity of the product item.

146. The method of claim 144 in which the coded data is indicative of at least one of a UPC and an EPC associated with the product item.

147. The method of any one of claims 129, 132, 140 or 141 in which the coded  
30 data is substantially invisible to an unaided human eye.

148. The ink composition of claim 49, wherein said hydrophilic group is selected from a PEG chain; an ammonium group; an acid group, including salts thereof; or a sulfonamide group.

149. The ink composition of claim 49, wherein said hydrophilic group is a  
5 sulfonic acid group or a metal salt thereof.

150. The ink composition of claim 49, wherein said hydrophilic group is  $-\text{SO}_3\text{Na}$  or  $-\text{SO}_3\text{K}$ .

151. The ink composition of claim 53, wherein  $\text{R}^{10}$  and  $\text{R}^{11}$  together are joined to form a bridged cyclic group.

10 152. The ink composition of claim 53, wherein  $\text{R}^{12}$  and  $\text{R}^{13}$  together are joined to form a bridged cyclic group.

153. The ink composition of claim 49, wherein M is Ni.

154. The method of claim 103, wherein said hydrophilic group is selected from a PEG chain; an ammonium group; an acid group, including salts thereof; or a sulfonamide  
15 group.

155. The method of claim 103, wherein said hydrophilic group is a sulfonic acid group or a metal salt thereof.

156. An IR-absorbing dye suitable for formulating a water-based inkjet, substantially as hereinbefore described with reference to the accompanying figures.

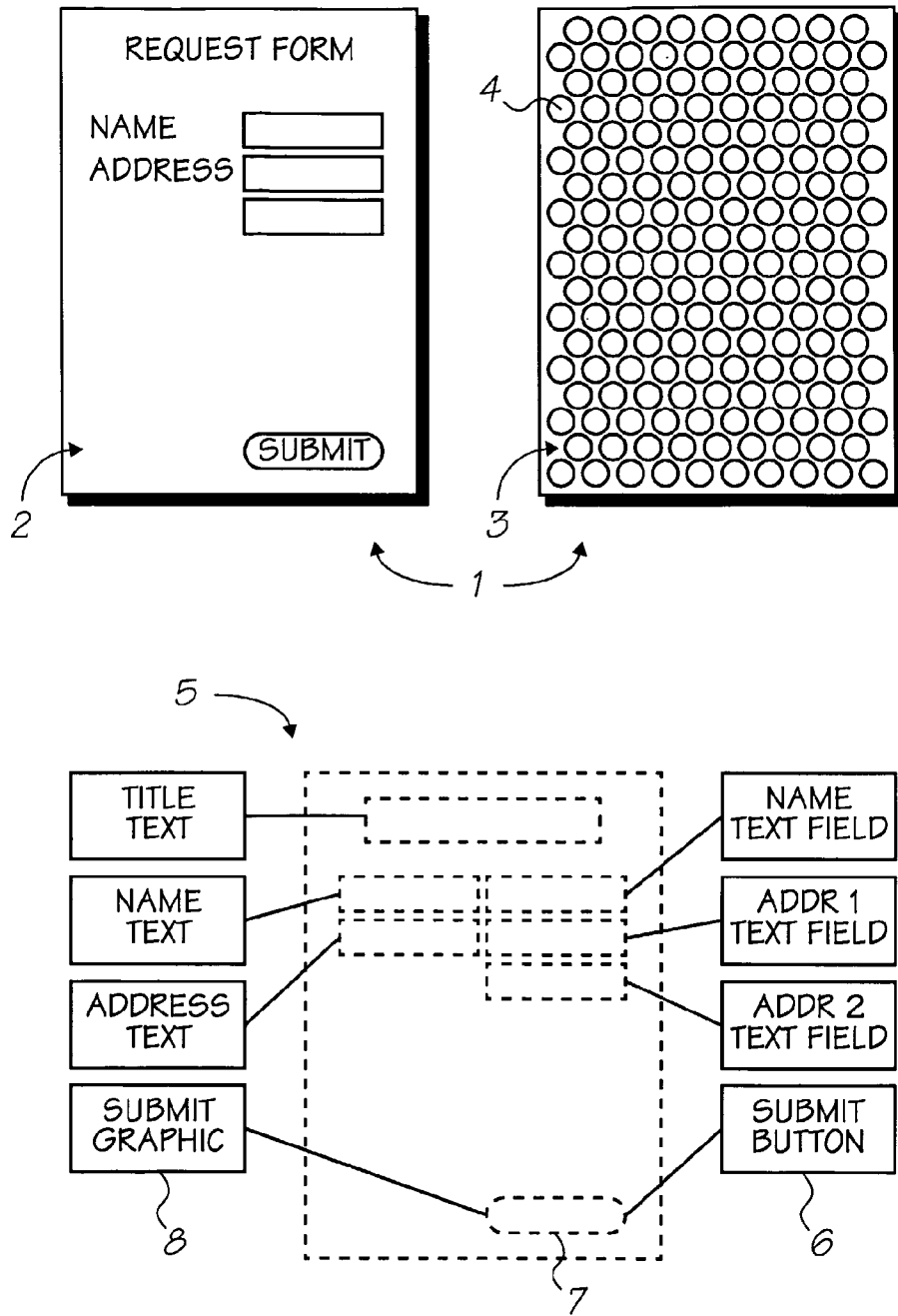

FIG. 1

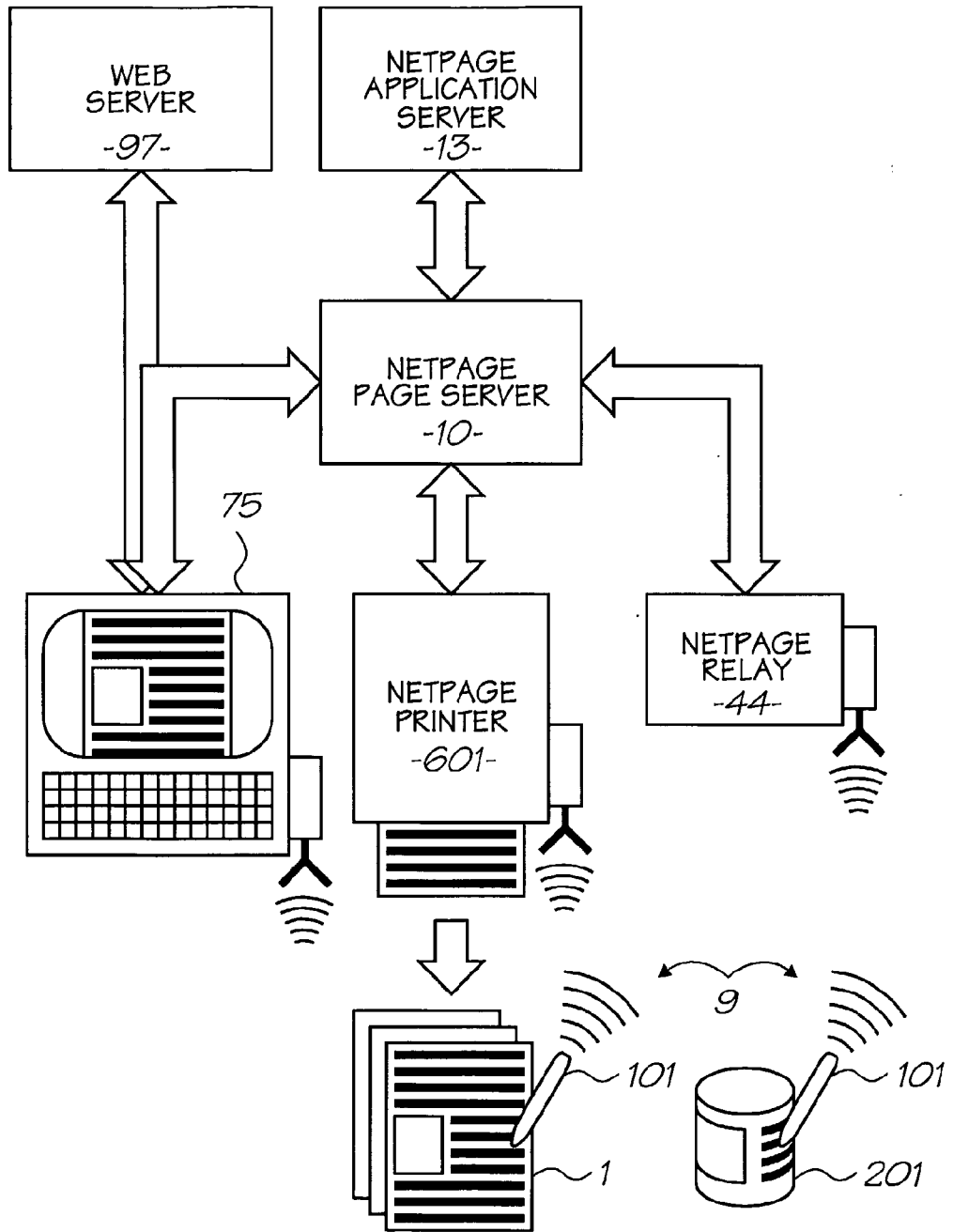

FIG. 2

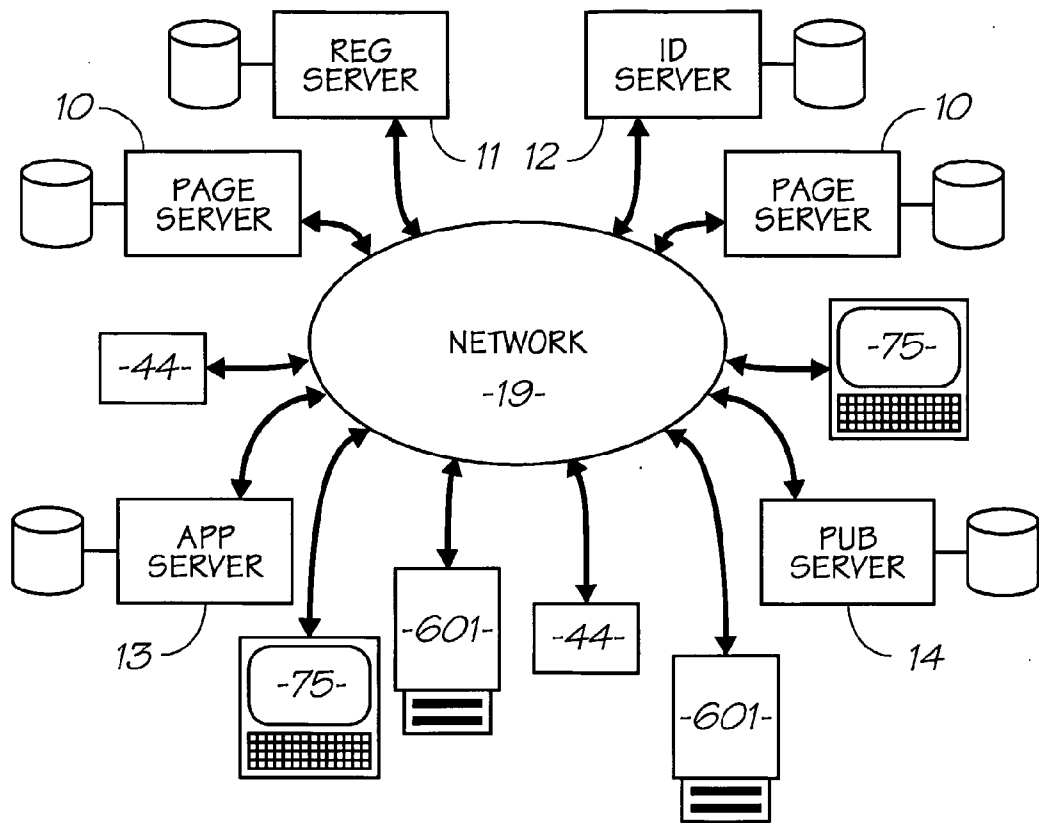

FIG. 3

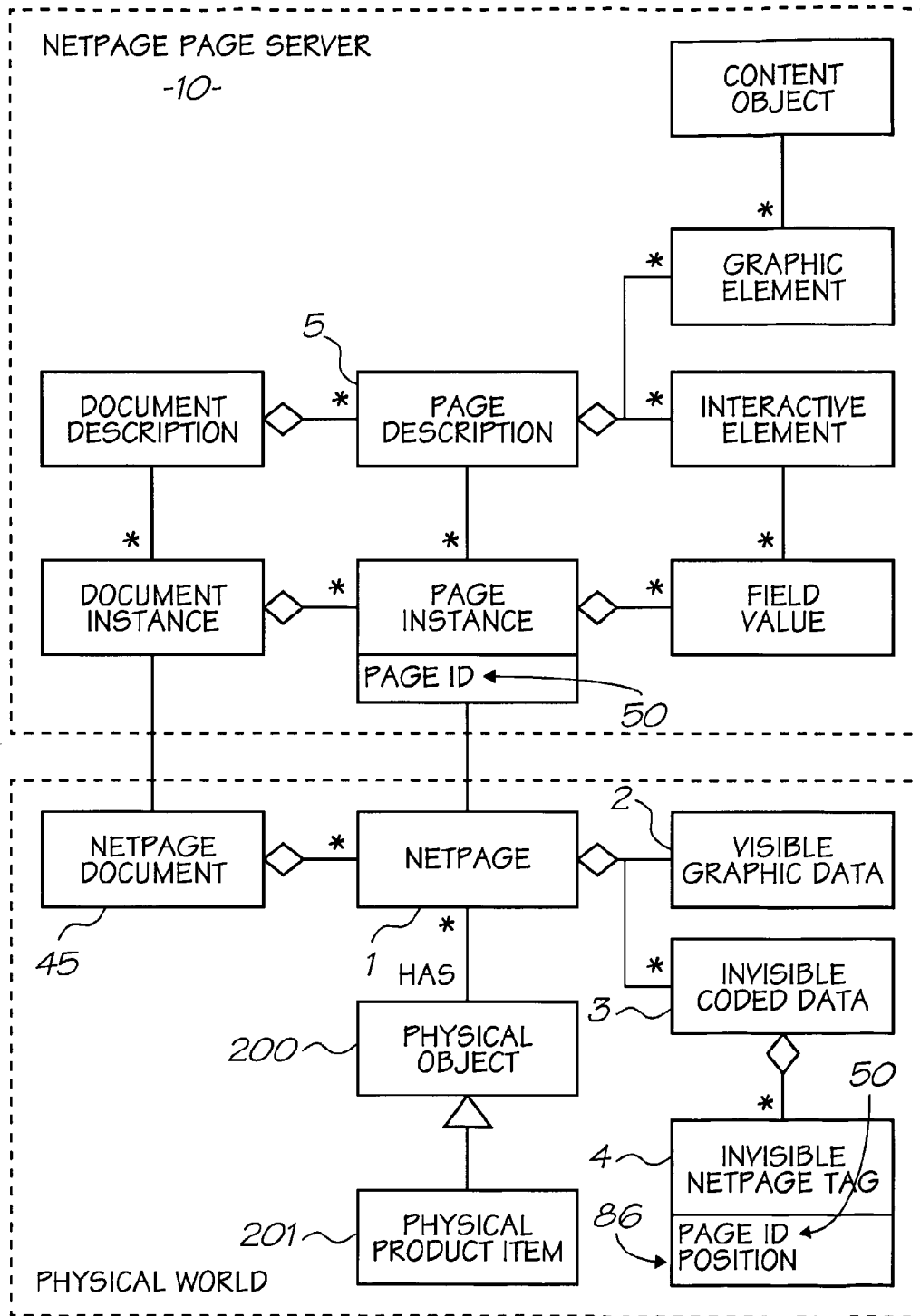

FIG. 4

5/20

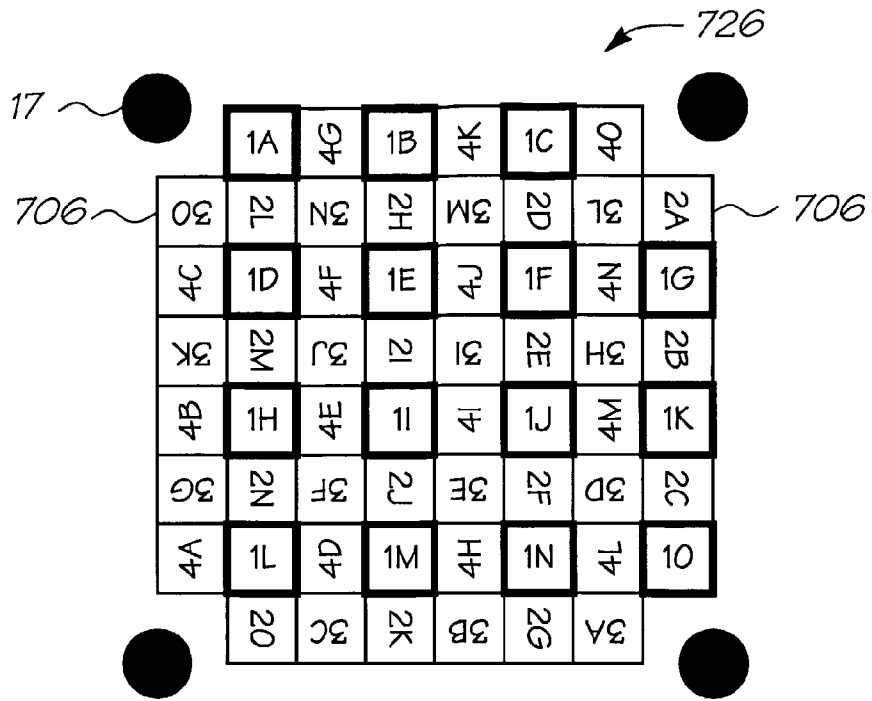

FIG. 5a

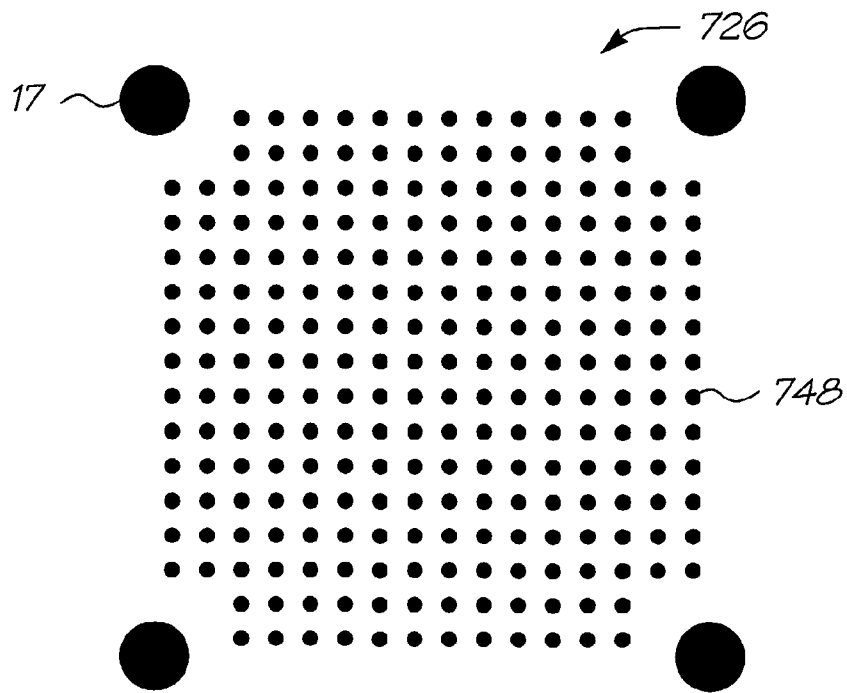

FIG. 5b

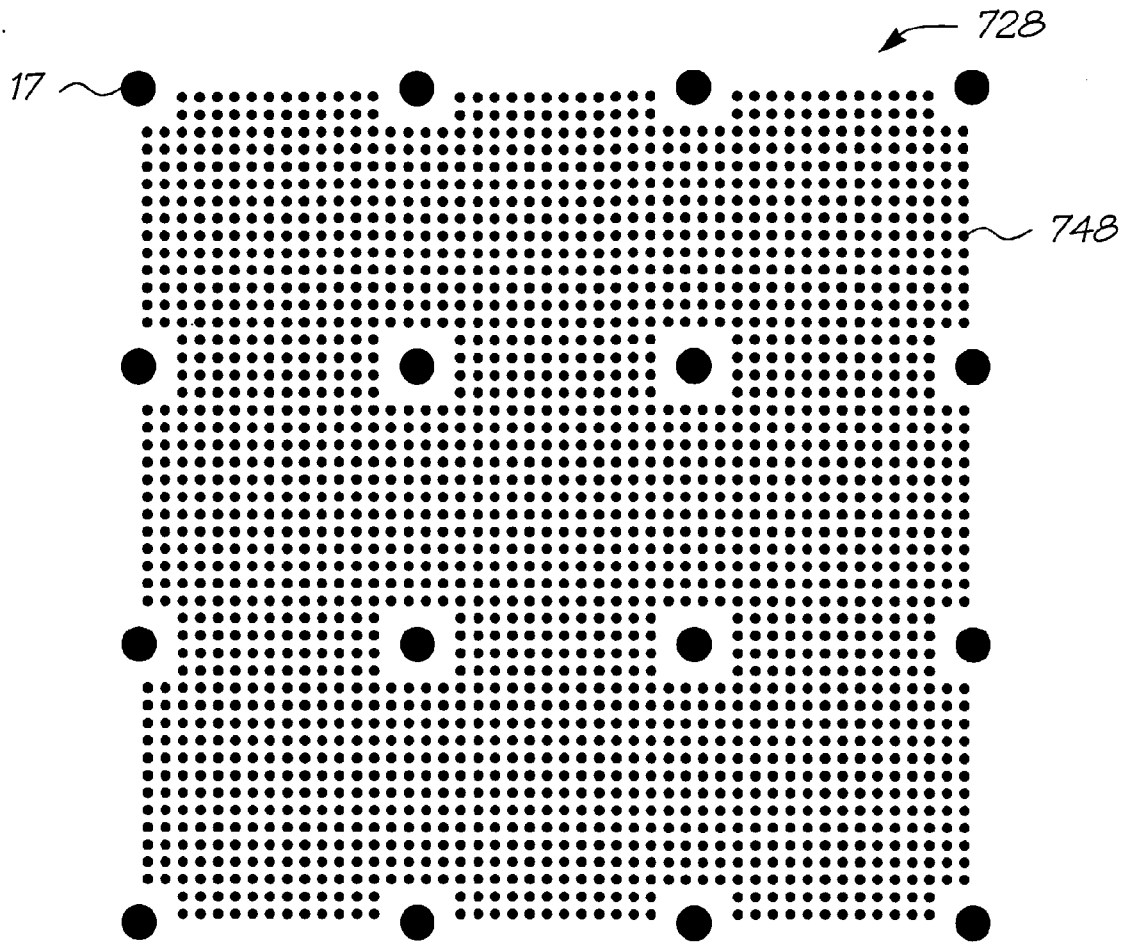

FIG. 5c



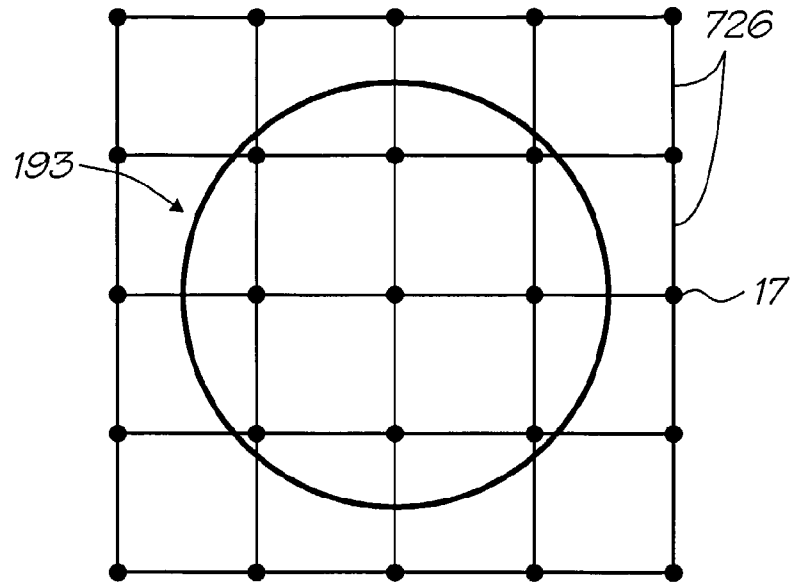

FIG. 5d

8/20

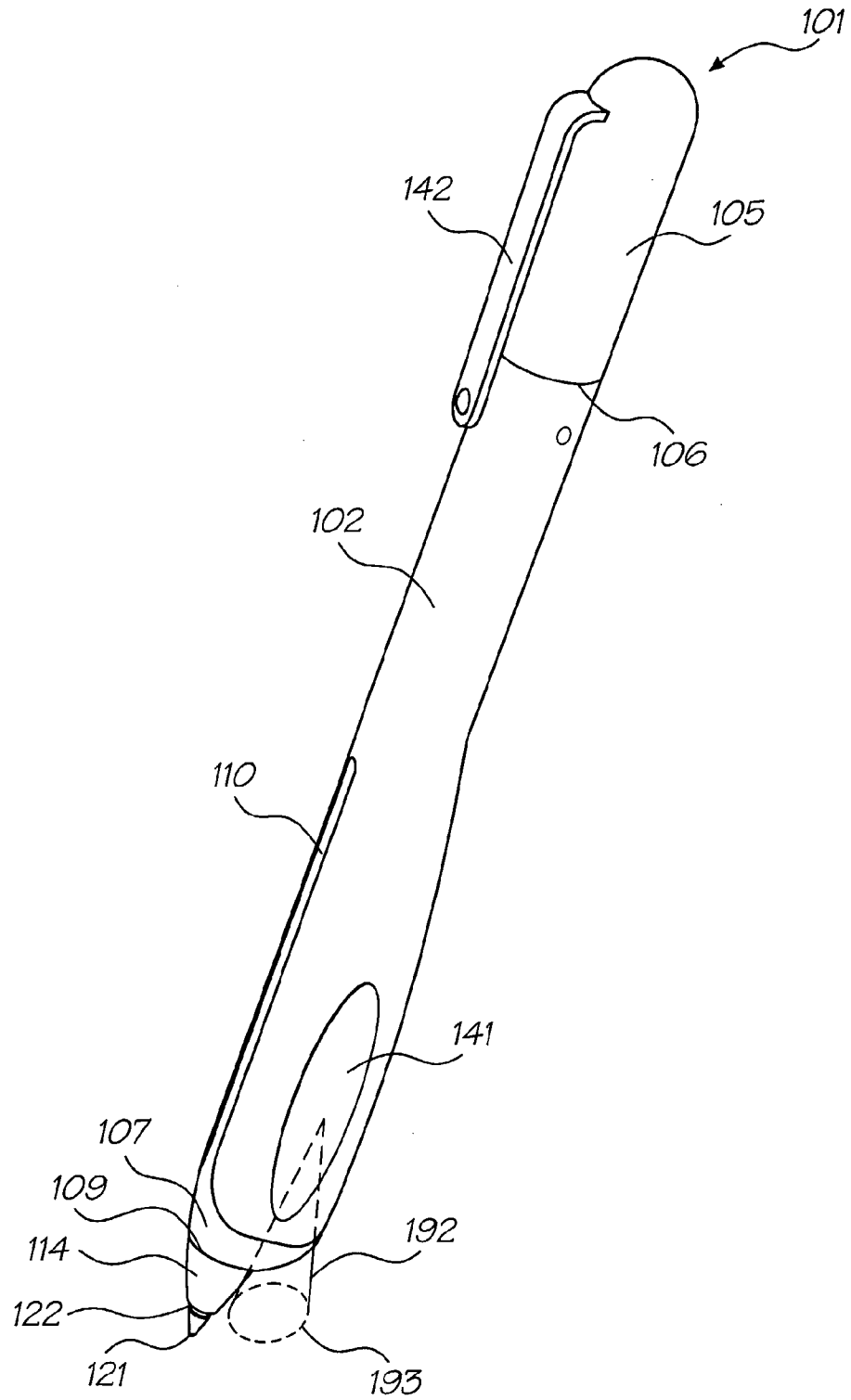

FIG. 6

9/20

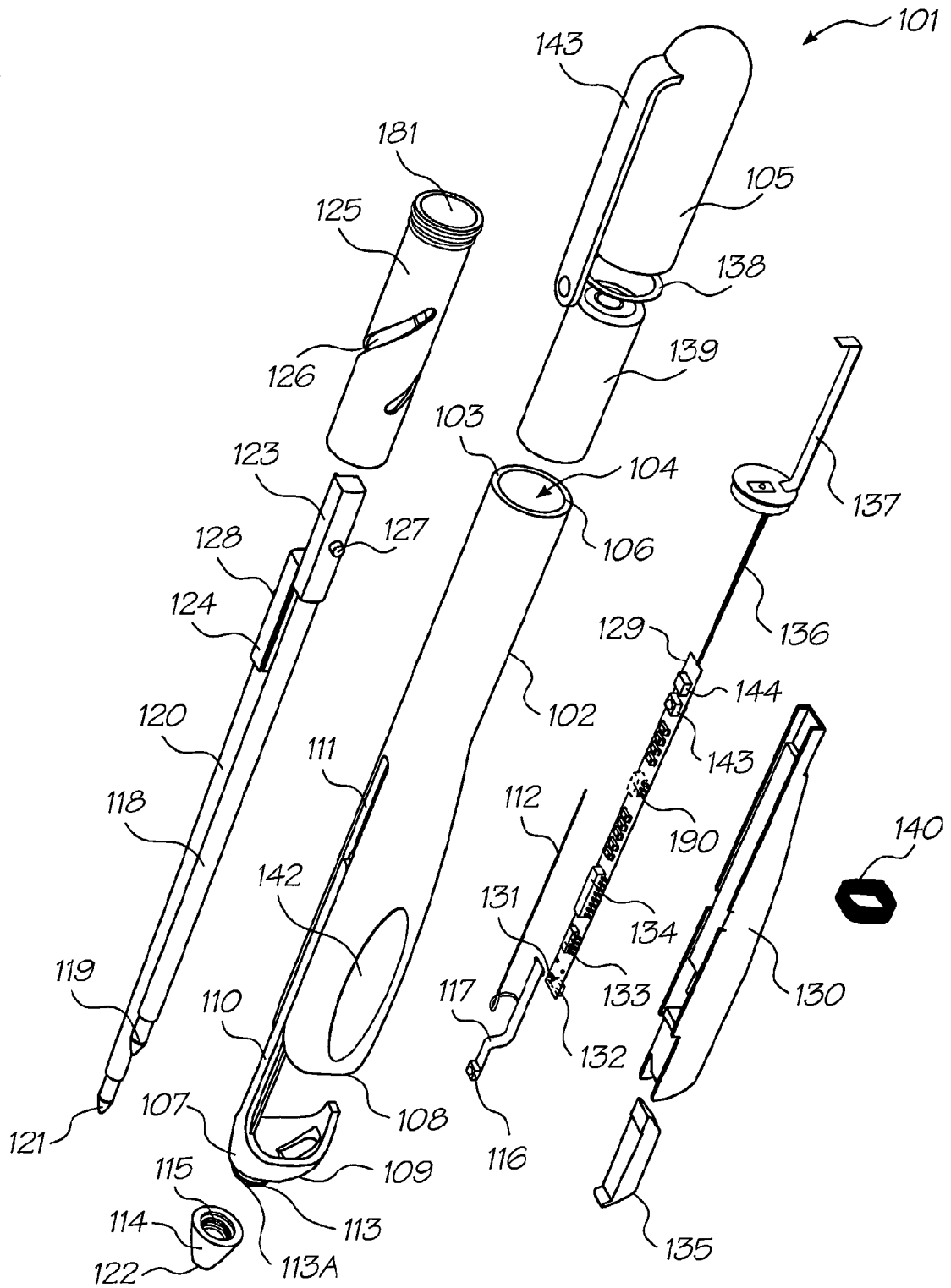

FIG. 7

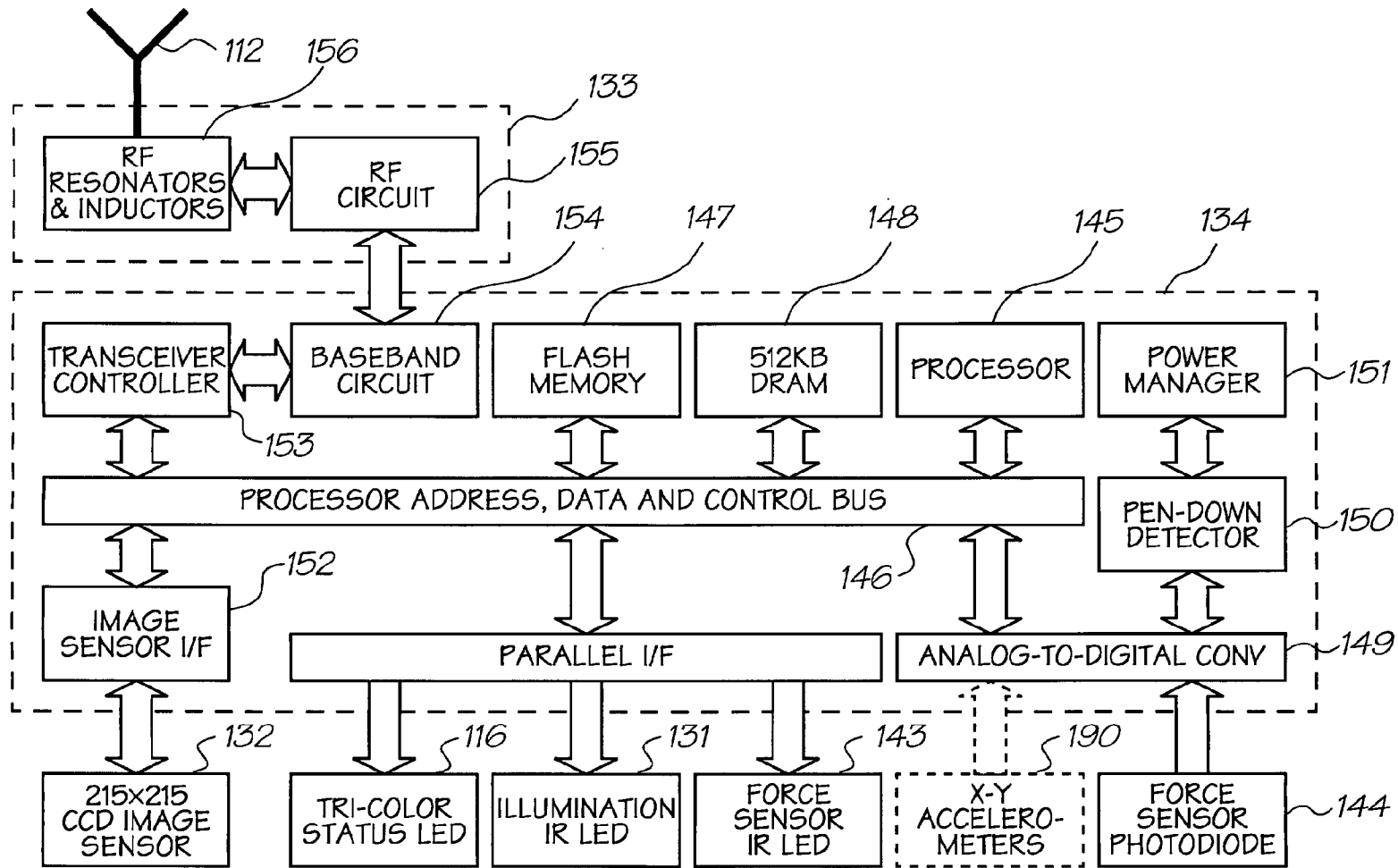

FIG. 8

11/20

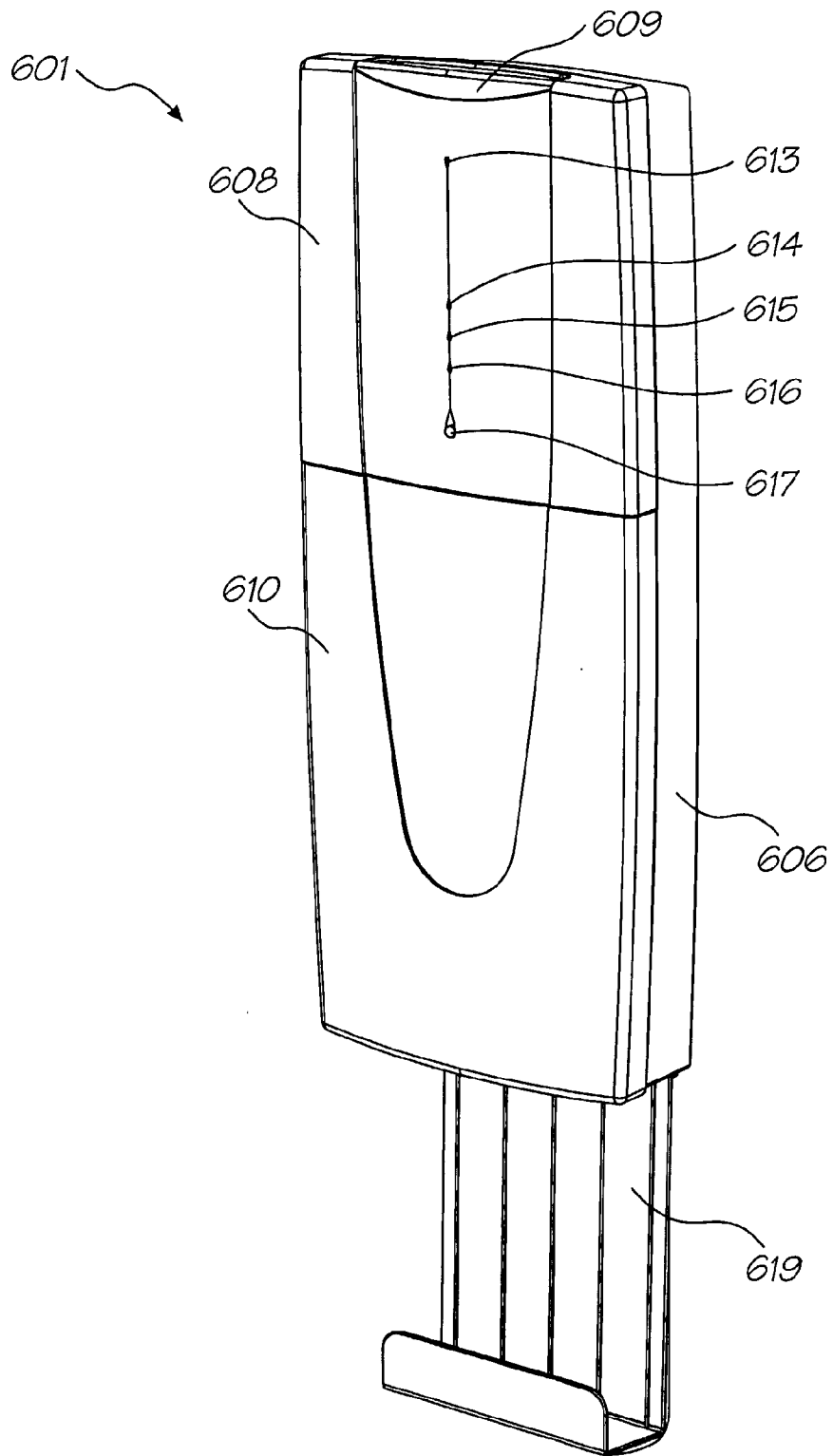

FIG. 9

12/20

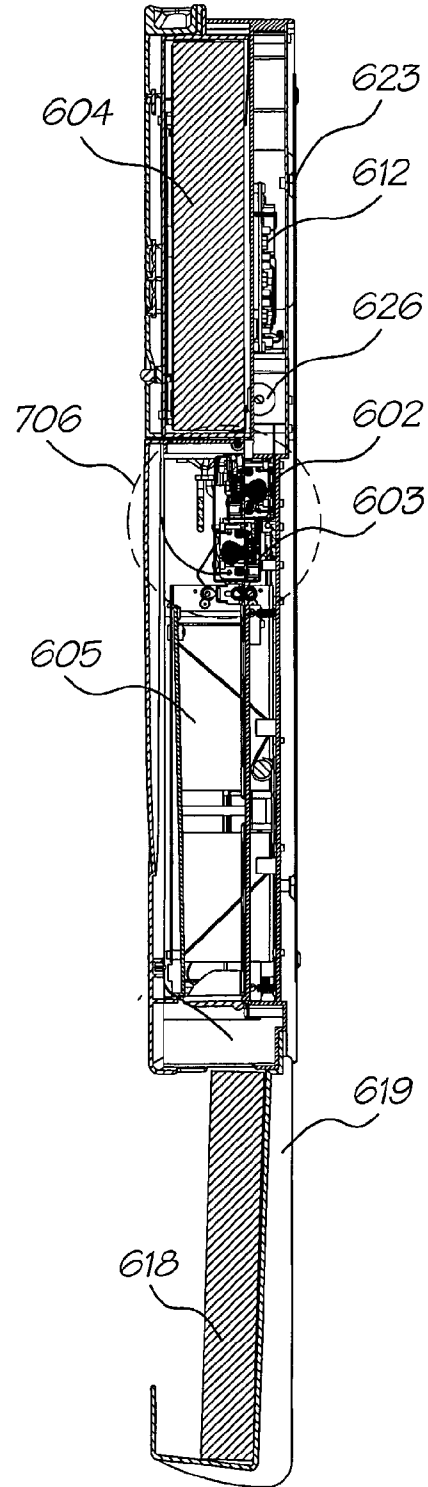

FIG. 10

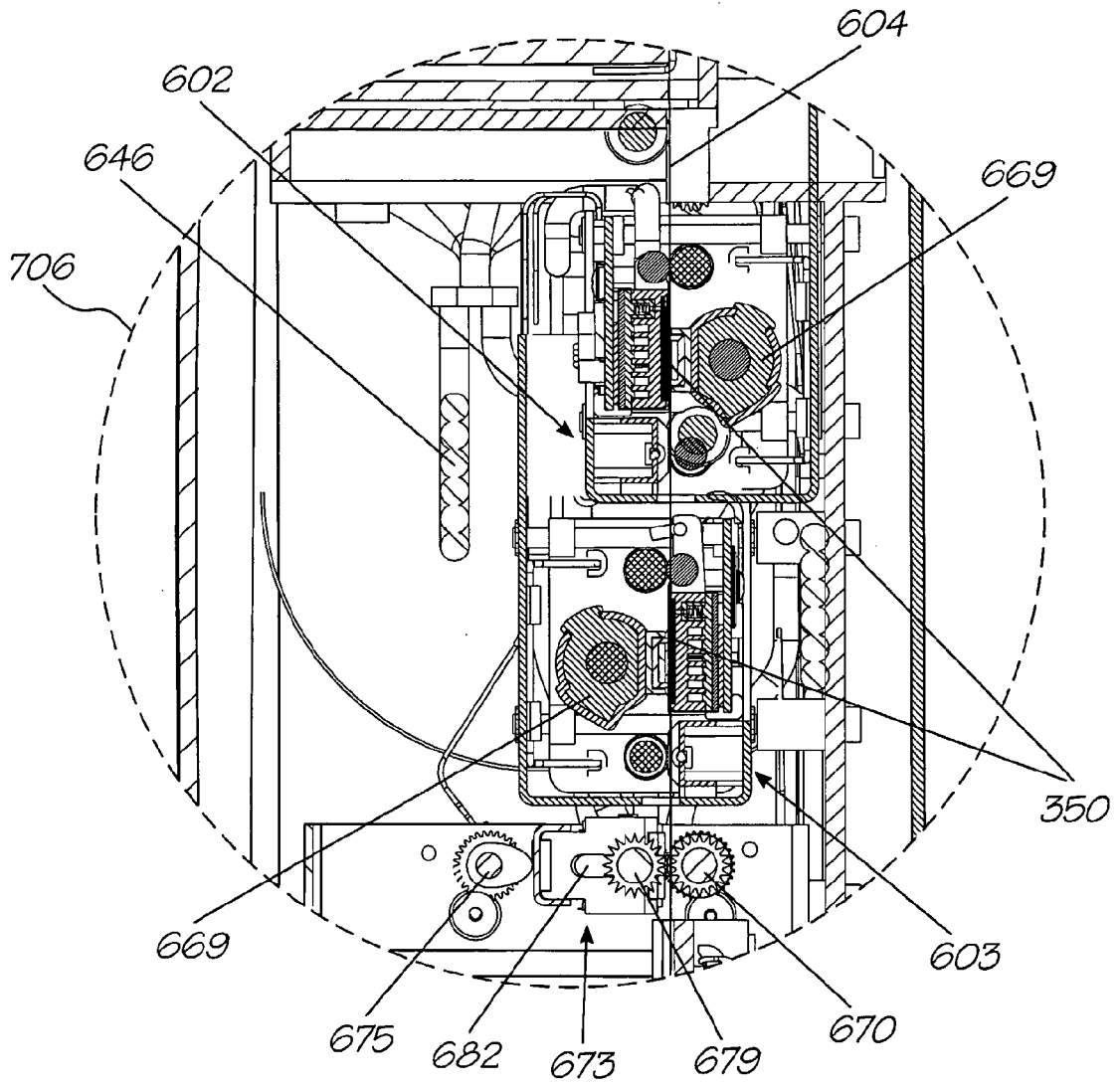

FIG. 10a

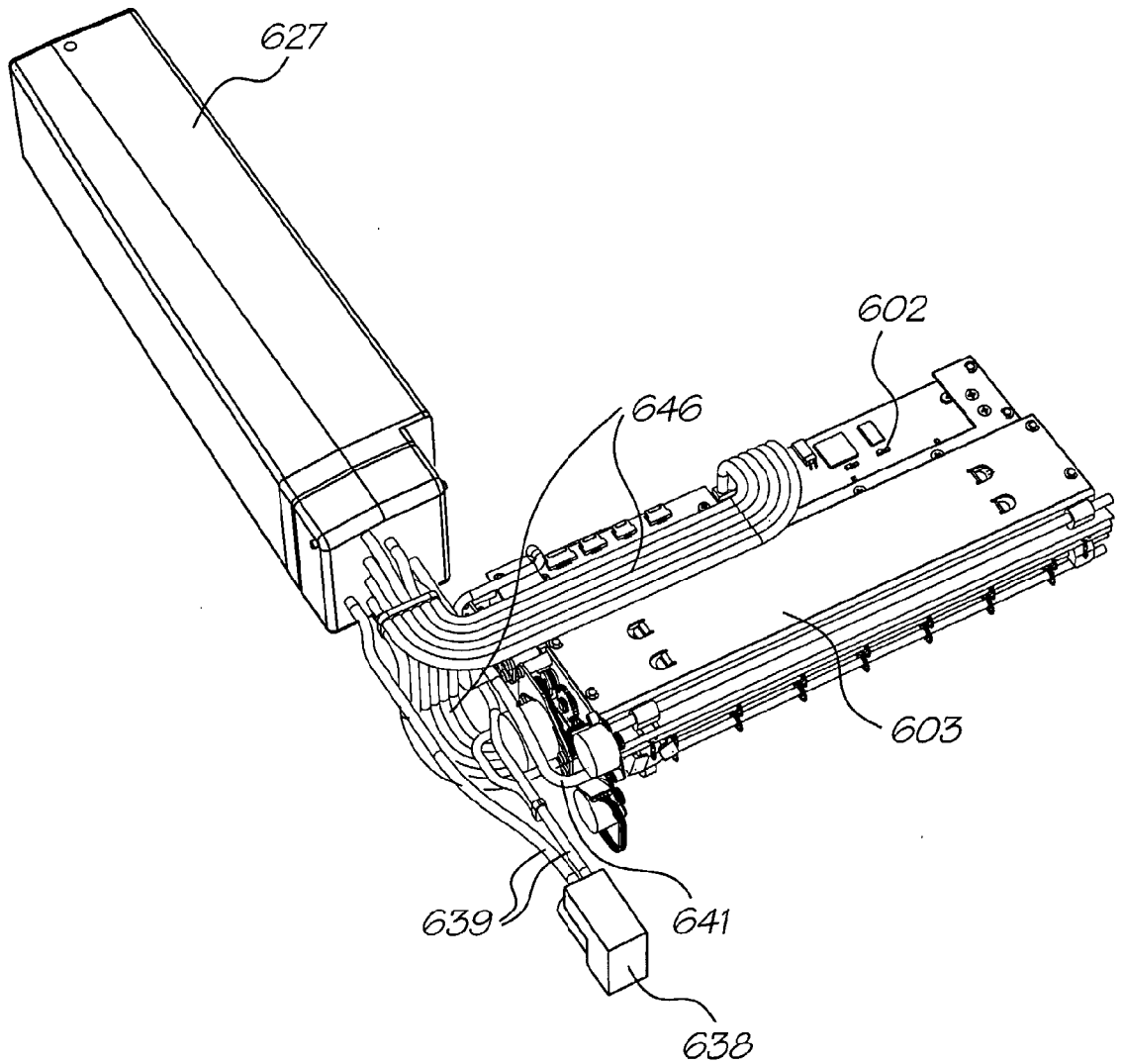

FIG. 11



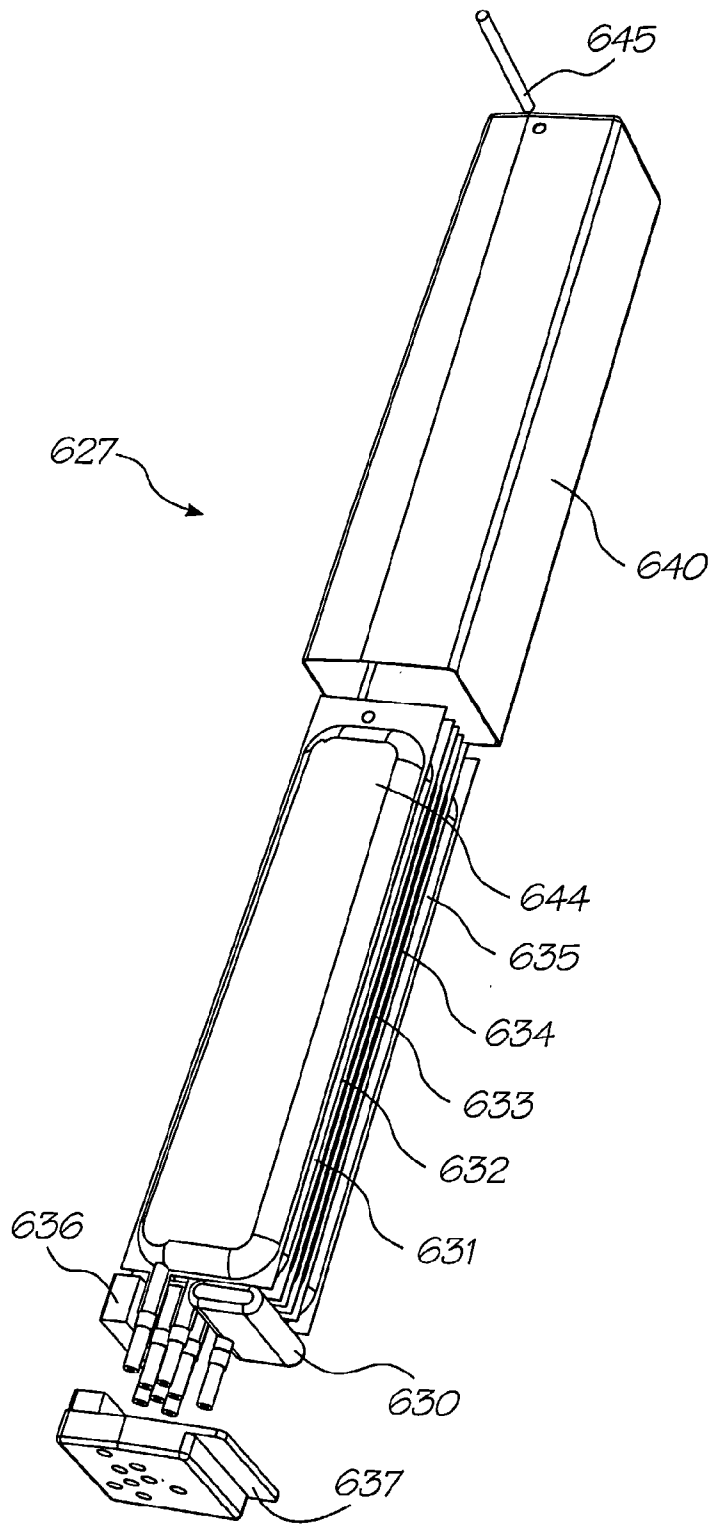

FIG. 12

16/20

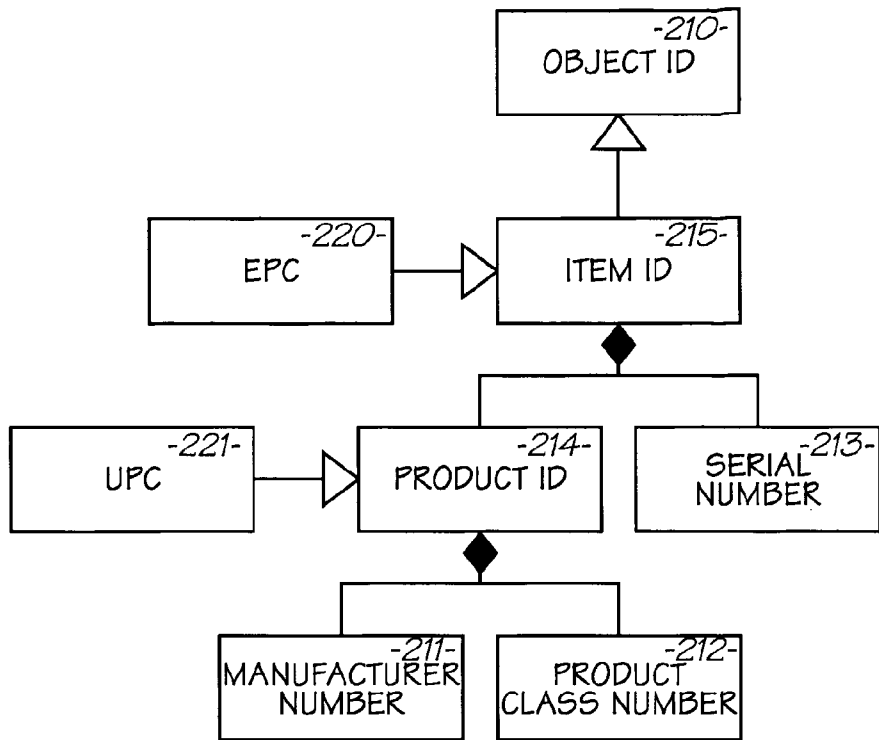

FIG. 13

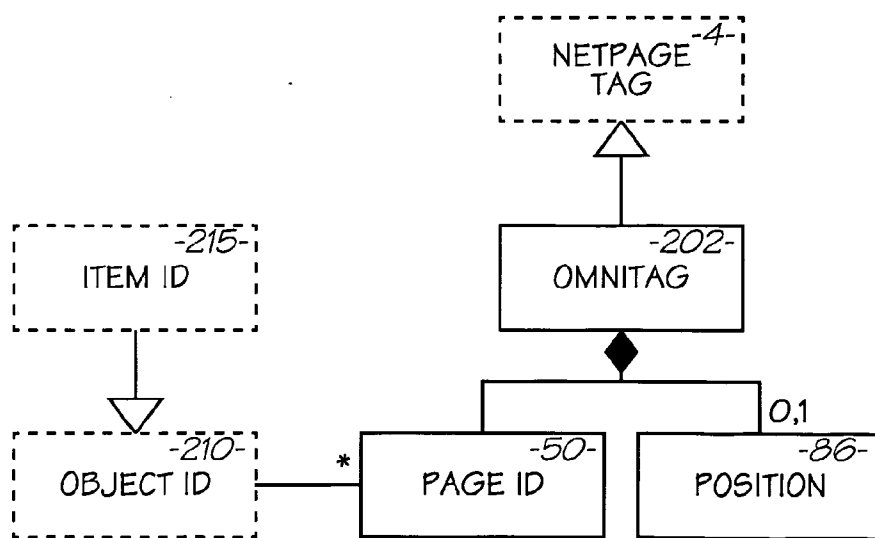

FIG. 14

17/20

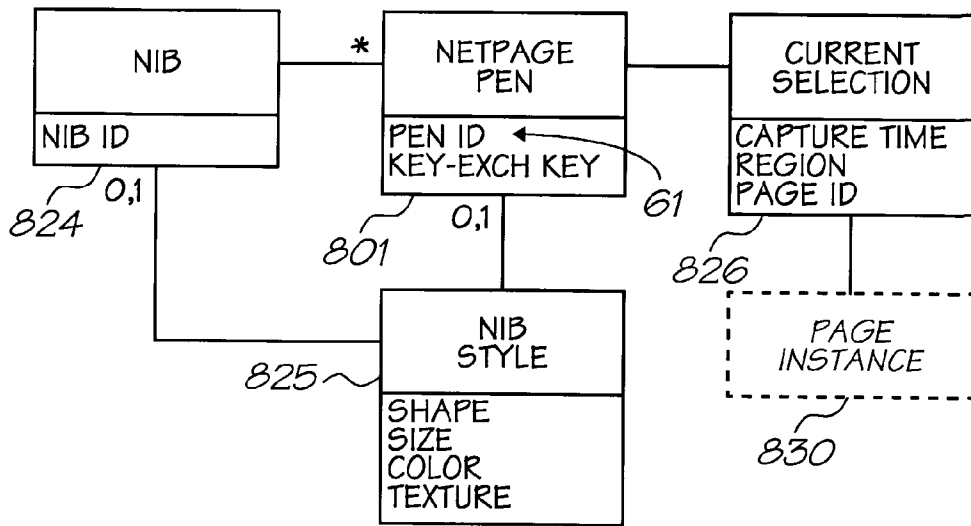

FIG. 15

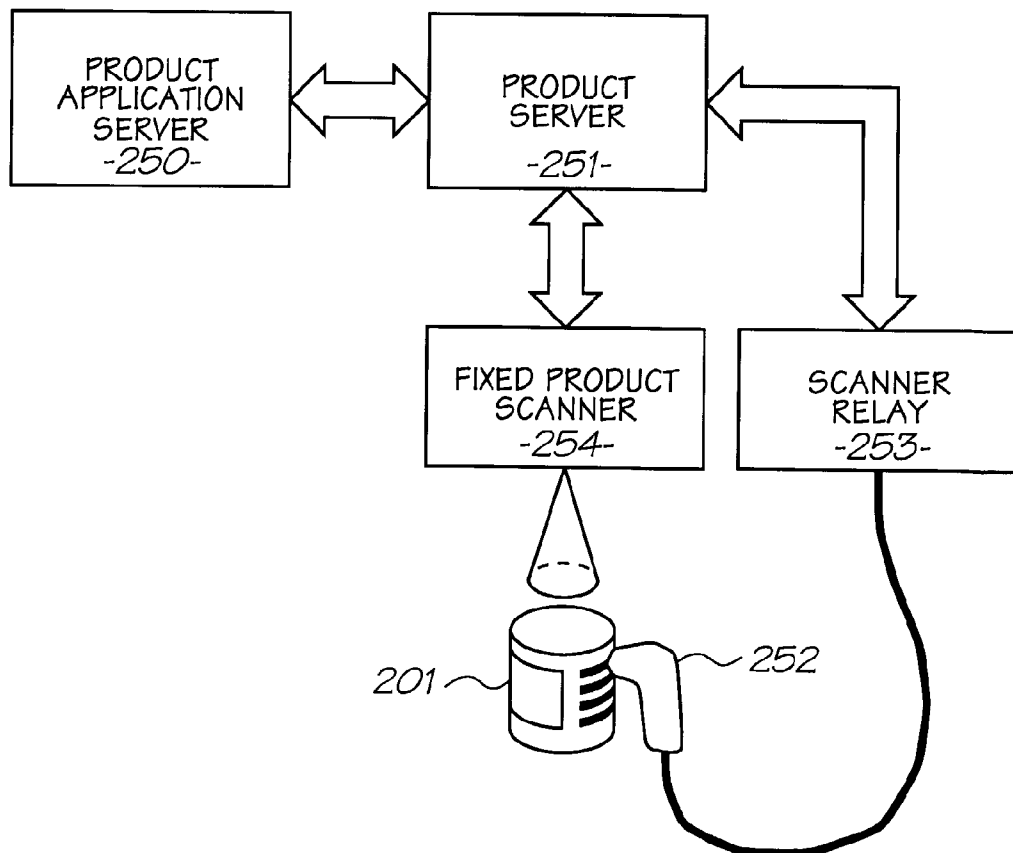

FIG. 16

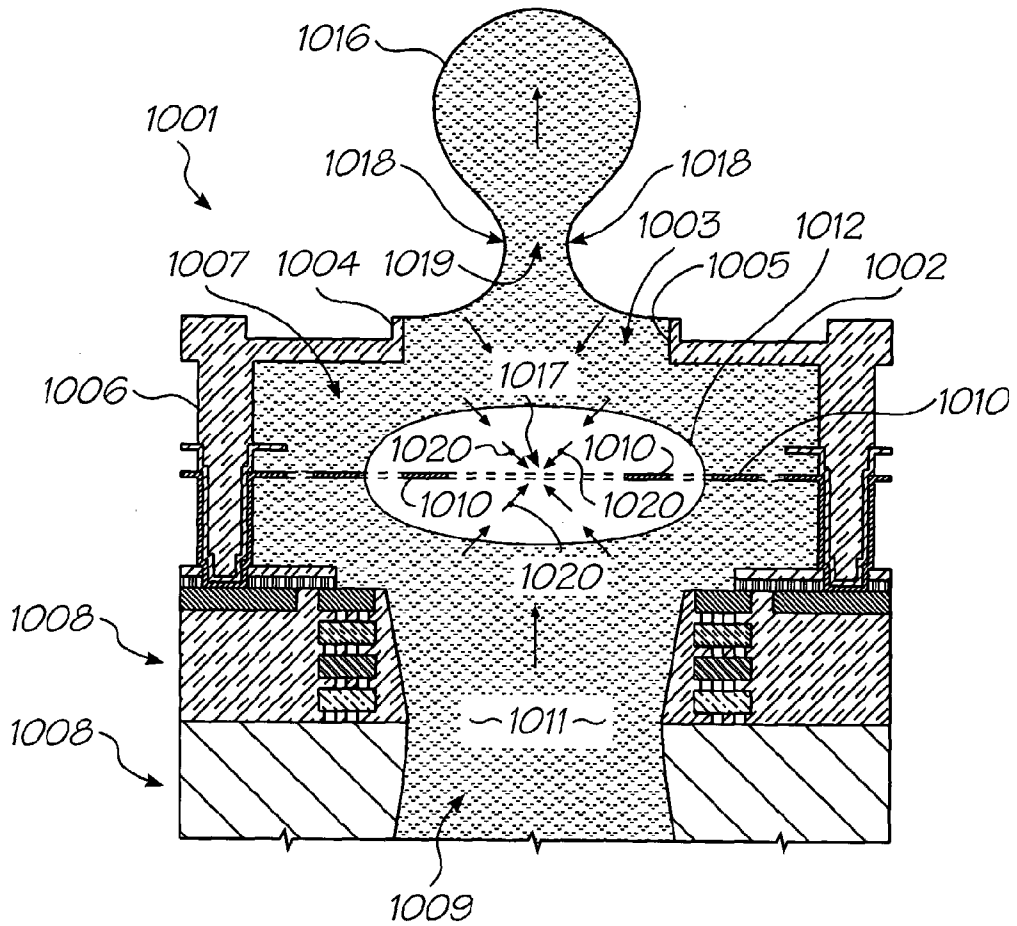

FIG. 17

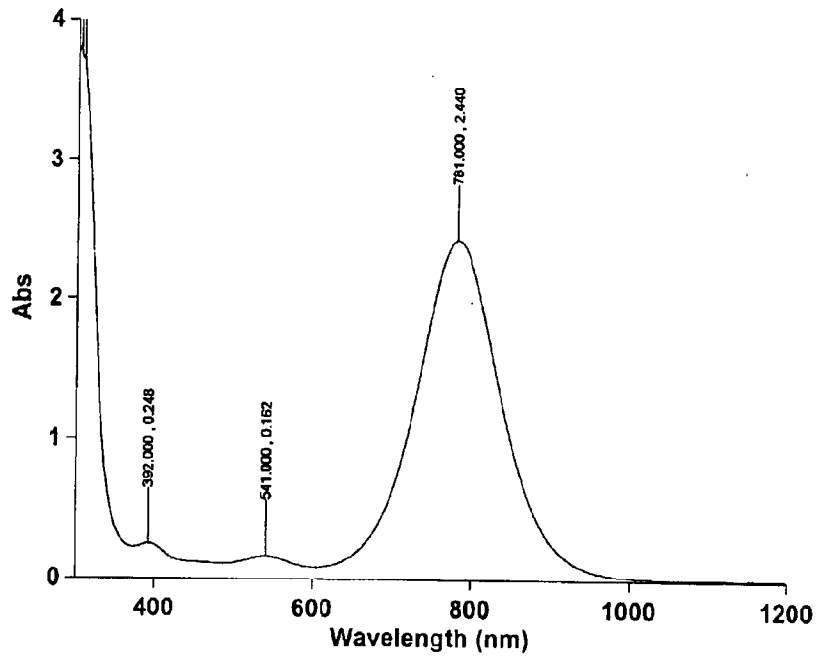

FIG. 18

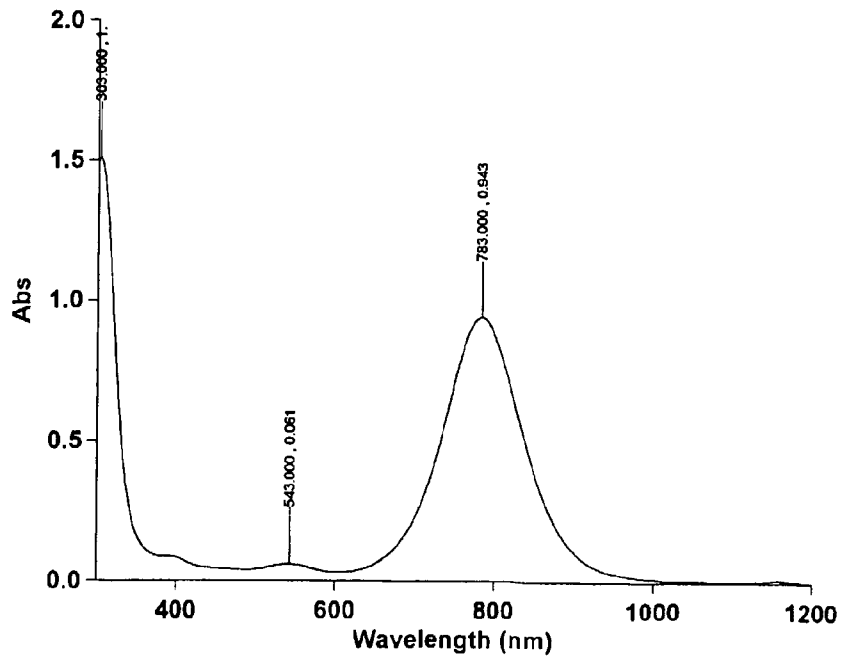

FIG. 19

20/20

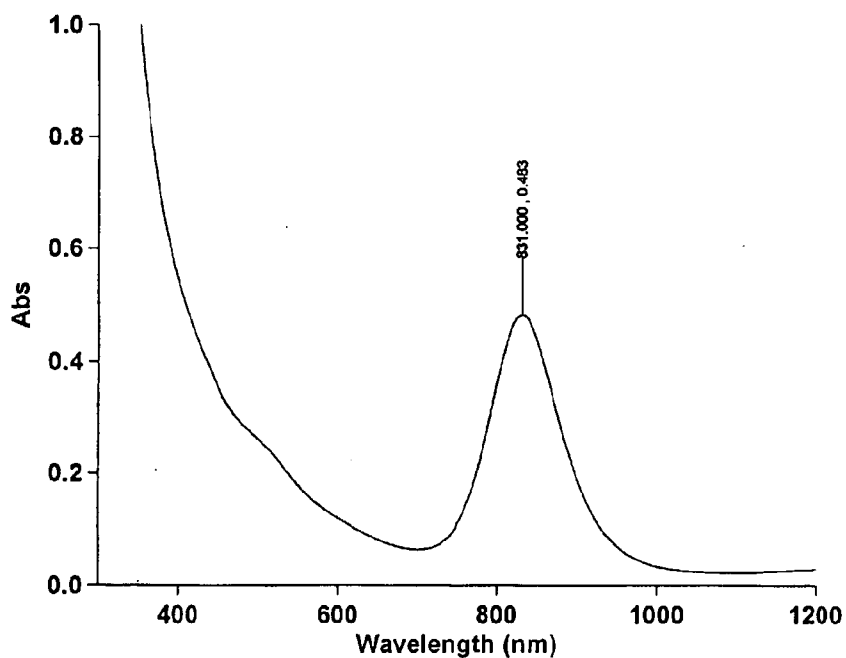

FIG. 20

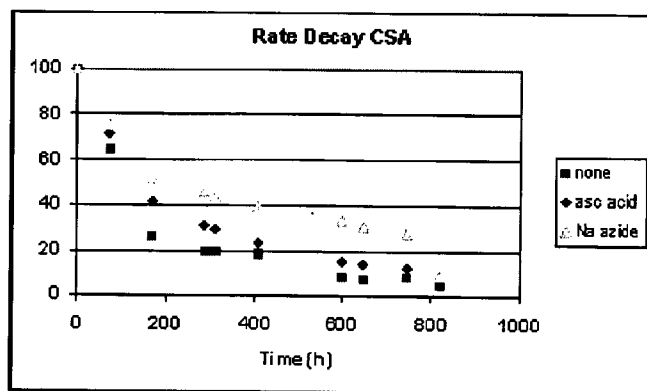

FIG. 21