



US0D1012134S

(12) **United States Design Patent**
Grenier et al.

(10) **Patent No.:** **US D1,012,134 S**

(45) **Date of Patent:** **** Jan. 23, 2024**

- (54) **DRAPER TRACK**
- (71) Applicant: **MacDon Industries Ltd.,** Winnipeg (CA)
- (72) Inventors: **Eric Grenier,** Somerset (CA); **Lance Willer,** Winnipeg (CA)
- (73) Assignee: **MacDon Industries LTD,** Winnipeg (CA)
- (**) Term: **15 Years**
- (21) Appl. No.: **29/842,999**
- (22) Filed: **Jun. 17, 2022**
- (51) **LOC (14) Cl.** **15-03**
- (52) **U.S. Cl.**
USPC **D15/28**
- (58) **Field of Classification Search**
USPC D15/10, 22-26, 28; D12/500, 572, D12/533-567, 579, 7
CPC B62D 55/04; B62D 55/084; B62D 55/14; B62D 55/02; B62D 55/125; B62D 55/08; B62D 55/00; B62D 55/244; B62D 55/07; B62D 55/24; B62D 55/26; B62D 55/18; B60C 11/00; B60C 11/0302; B60C 11/0306; B60C 11/0311; B60C 11/0313; A01D 61/02; A01D 75/00; A01D 34/14; B65G 15/42
See application file for complete search history.

7,958,711 B1 *	6/2011	Sauerwein	A01D 57/20
			56/181
8,281,561 B2 *	10/2012	Dow	A01D 61/002
			56/181
8,402,728 B2 *	3/2013	Kidd	A01D 61/02
			198/844.2
8,484,938 B2 *	7/2013	Cormier	A01D 61/002
			56/181
9,622,412 B2 *	4/2017	Hasenour	A01D 61/002
10,182,528 B2 *	1/2019	Hasenour	A01D 61/02
10,257,982 B2	4/2019	Martens et al.	
10,390,486 B2	8/2019	Hasenour et al.	
2011/0308221 A1 *	12/2011	Sauerwein	A01D 41/14
			56/181
2015/0007544 A1 *	1/2015	Herringshaw	A01D 34/40
			56/181

* cited by examiner

Primary Examiner — Mark A Goodwin
(74) *Attorney, Agent, or Firm* — Miller Canfield

(57) **CLAIM**

The ornamental design for a draper track, as shown and described.

DESCRIPTION

FIG. 1 is a top, rear perspective view of a draper header showing our new design;
 FIG. 2 is a bottom, rear perspective view thereof;
 FIG. 3 is a rear view thereof;
 FIG. 4 is a front view thereof;
 FIG. 5 is a left side view thereof;
 FIG. 6 is a right side view thereof;
 FIG. 7 is a top plan view thereof; and,
 FIG. 8 is a bottom plan view thereof.
 The broken lines in the drawings are included for purposes of illustrating portions of the draper track which form no part of the claimed design.

1 Claim, 3 Drawing Sheets

(56) **References Cited**
 U.S. PATENT DOCUMENTS
 2,875,887 A * 3/1959 Hinchcliffe B65G 15/42 D34/29
 4,316,536 A * 2/1982 Verbeek B29C 65/02 156/137
 7,802,417 B2 * 9/2010 Sauerwein A01D 41/14 56/181

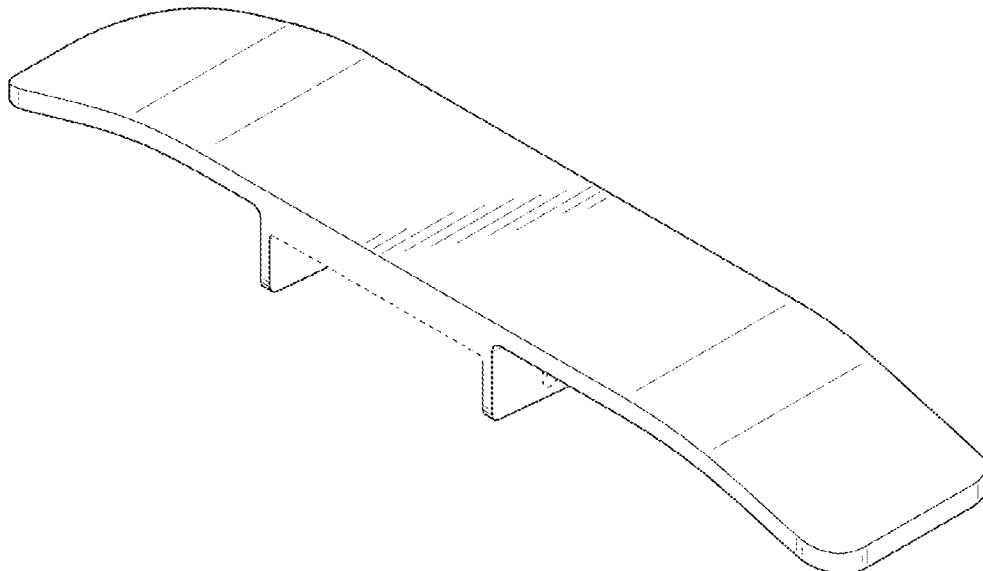

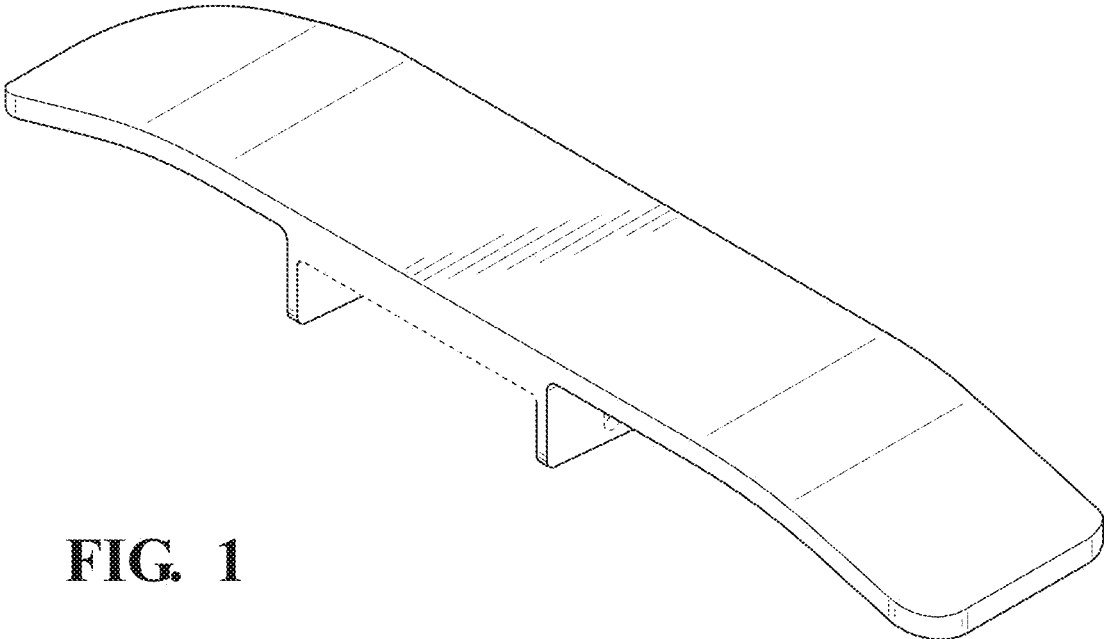

FIG. 1

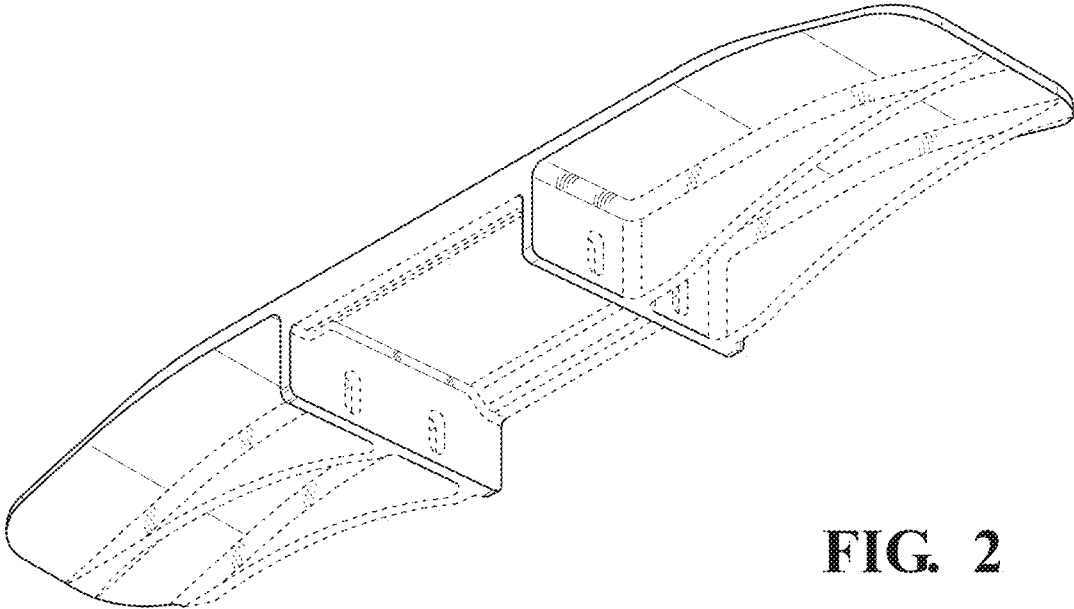

FIG. 2

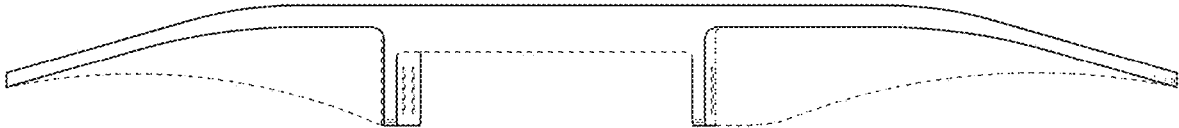

FIG. 3

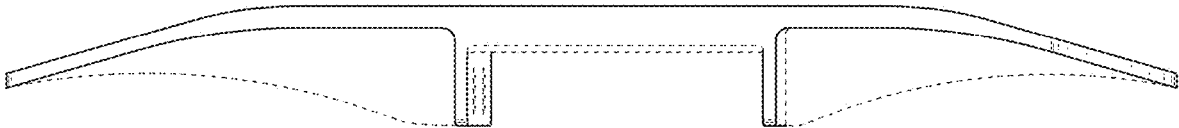

FIG. 4

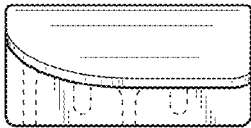

FIG. 5

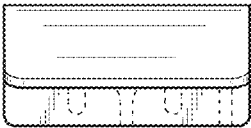

FIG. 6

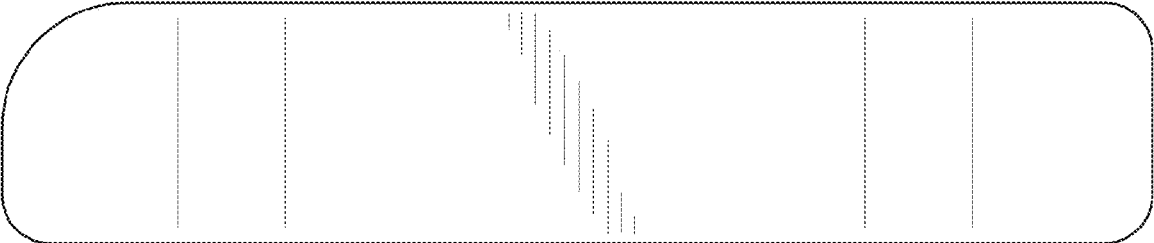

FIG. 7

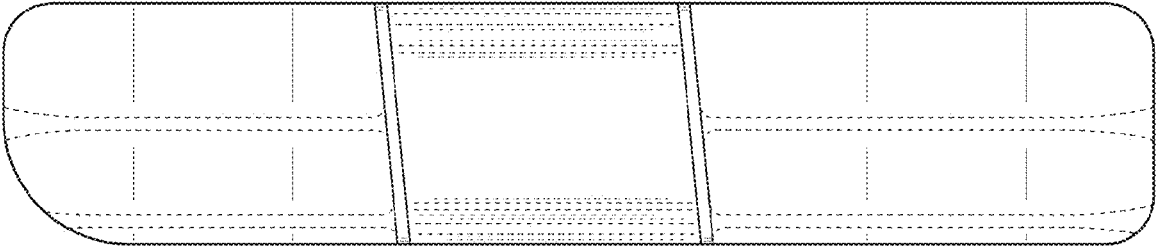

FIG. 8