



- (51) International Patent Classification:
A61M 5/315 (2006.01)
- (21) International Application Number:
PCT/US2015/021171
- (22) International Filing Date:
18 March 2015 (18.03.2015)
- (25) Filing Language: English
- (26) Publication Language: English
- (30) Priority Data:
61/955,527 19 March 2014 (19.03.2014) US
61/970,018 25 March 2014 (25.03.2014) US
- (71) Applicant: **BAYER MEDICAL CARE INC.** [US/US]; 1 Bayer Drive, Indianola, PA 15051 (US).
- (72) Inventors: **SCHULTE, Stephen**; 1165 Woodhill Drive, Gibsonia, PA 15044 (US). **SWENGLISH, Christopher, L.**; 227 Rilla Drive, Connellsville, PA 15425 (US). **CASTILLO, Luis**; 381 Celery Circle, Oviedo, FL 32765 (US). **LANG, Charles, A.**; 2419 Bellwood Drive, Pittsburgh, PA 15237 (US).
- (74) Agents: **SCHRAMM, David** et al.; 1 Bayer Drive, Indianola, PA 15051 (US).

- (81) Designated States (unless otherwise indicated, for every kind of national protection available): AE, AG, AL, AM, AO, AT, AU, AZ, BA, BB, BG, BH, BN, BR, BW, BY, BZ, CA, CH, CL, CN, CO, CR, CU, CZ, DE, DK, DM, DO, DZ, EC, EE, EG, ES, FI, GB, GD, GE, GH, GM, GT, HN, HR, HU, ID, IL, IN, IR, IS, JP, KE, KG, KN, KP, KR, KZ, LA, LC, LK, LR, LS, LU, LY, MA, MD, ME, MG, MK, MN, MW, MX, MY, MZ, NA, NG, NI, NO, NZ, OM, PA, PE, PG, PH, PL, PT, QA, RO, RS, RU, RW, SA, SC, SD, SE, SG, SK, SL, SM, ST, SV, SY, TH, TJ, TM, TN, TR, TT, TZ, UA, UG, US, UZ, VC, VN, ZA, ZM, ZW.
- (84) Designated States (unless otherwise indicated, for every kind of regional protection available): ARIPO (BW, GH, GM, KE, LR, LS, MW, MZ, NA, RW, SD, SL, ST, SZ, TZ, UG, ZM, ZW), Eurasian (AM, AZ, BY, KG, KZ, RU, TJ, TM), European (AL, AT, BE, BG, CH, CY, CZ, DE, DK, EE, ES, FI, FR, GB, GR, HR, HU, IE, IS, IT, LT, LU, LV, MC, MK, MT, NL, NO, PL, PT, RO, RS, SE, SI, SK, SM, TR), OAPI (BF, BJ, CF, CG, CI, CM, GA, GN, GQ, GW, KM, ML, MR, NE, SN, TD, TG).

Published:
— with international search report (Art. 21(3))

(54) Title: SYSTEM FOR SYRINGE ENGAGEMENT TO AN INJECTOR

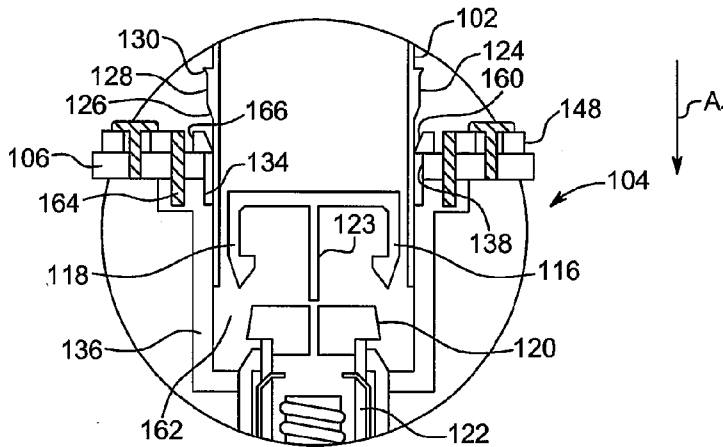

FIG. 4A

(57) Abstract: An injector system for injecting fluid includes a syringe and an injector. The syringe includes a body and a plunger movably disposed within the body. The plunger has at least one flexible leg extending toward the rearward end of the body. The injector has a housing with a front plate, a drive member at least partially disposed within the housing and operable to engage the plunger, and a syringe release assembly operable to release the syringe. The syringe assembly includes a syringe release gear that forms an enclosure for receiving the syringe when the syringe is fully seated within the housing and a plunger release tube surrounding at least a portion of the drive member. The plunger release tube has a first end rotationally engaged with the syringe release gear. Rotation of the syringe release assembly releases the at least one flexible leg from the drive member.

WO 2015/142995 A1

SYSTEM FOR SYRINGE ENGAGEMENT TO AN INJECTOR

CROSS-REFERENCE TO RELATED APPLICATIONS

[0001] This application claims priority to U.S. Provisional Application No. 61/955,527, filed March 19, 2014 and U.S. Provisional Application No. 61/970,018, filed on March 25, 2014, the disclosures of which are incorporated herein by reference in their entirety.

BACKGROUND

Field

[0002] This application relates to medical injectors and syringes, syringe interfaces, and syringe plungers for use therewith. More particularly, the present application relates to front-loading medical injectors and syringes, syringe interfaces, and syringe plungers for use with new or existing medical injectors such that the syringe is mountable upon and removable from the injectors by a syringe latch.

Description of Related Art

[0003] Medical injectors and syringes for injecting contrast media into a patient for imaging biological structures are known in the art. For example, with reference to **FIG. 1**, a conventional injector apparatus **10** for injecting a liquid contrast media into a vascular system of an animal is disclosed in United States Patent No. 5,383,858, which is incorporated herein by reference. This injector apparatus **10** has a front-loading construction. The apparatus of **FIG. 1** utilizes a syringe **12** capable of being front-loaded into a mounting assembly **14** associated with a front wall **16** of a housing **18** of an injector **20** by a first releasable mechanism **22**. The syringe **12** is capable of functioning in an injection operation without the use of a pressure jacket (although the syringe may be used in an injector with a pressure jacket).

[0004] With continued reference to **FIG. 1**, the mounting assembly **14** is provided with an essentially cylindrical interface **26** for receiving a rearward end of the syringe **12**. The interface **26** includes an annular surface **28**, which may be cylindrical or conically tapered. The annular surface **28** includes a distal ledge, which is engaged by tabs **30** on the rearward end of the syringe **12**. The syringe **12** is inserted into the cylindrical interface **26** until the tabs **30** engage the distal ledge to secure the syringe **12** to the injector **20**.

[0005] The syringe **12** comprises an elongated main tubular body or barrel **32** and a coaxial discharge injection section **34**, interconnected by an intermediate conical portion **36**. A plunger **38** is slidably positioned within the tubular body **32** and is connectable to a second

releasable mechanism **40** on a piston **42** in the injector housing **18**. The second releasable mechanism **40** is formed in part by the plunger **38** and in part by the piston **42**.

[0006] The piston **42** and plunger **38** cooperate to eject fluid contained within the syringe **12** in a desired quantity and at a desired rate. The second releasable mechanism **40** is designed to facilitate axial movement of the plunger **38** in either direction when actuated. The second releasable mechanism **40** is also designed to engage or disengage the plunger **38** from the piston **42** no matter where the plunger **38** sits in tubular body **32**.

[0007] In operation, the syringe **12** is mounted by inserting the syringe **12** into the interface **26** in the mounting assembly **14**. The tabs **30** initially move past the annular surface **28** where they engage the distal ledge to securely hold the syringe **12** to the mounting assembly **14**. The mounting assembly **14** further includes a forwardly projecting annular ring or collar **44**, which functions to assure perpendicular engagement between the plunger **38** and piston **42**. As explained above, the forwardly projecting annular ring or collar **44** also functions as a seal between a resilient annular sealing flange **46** on the syringe **12** and the mounting assembly **14**.

[0008] The resilient annular sealing flange **46** surrounds the tubular body **32** of the syringe **12** and is disposed forward of the tabs **30** a preselected distance essentially equal to a width of the annular surface **28**. Thus, when the syringe **12** is inserted into the interface **26** in the mounting assembly **14** until the sealing flange **46** engages the annular ring **44**, the annular ring **44** and flange **46** create a seal between the syringe **12** and the mounting assembly **14**.

[0009] With further reference to **FIG. 1**, the apparatus also includes a system for transmitting syringe information from the syringe **12** to an injector controller **51**. The syringe **12** is provided with an encoding device **48** forward of the tabs **30** but rearward of the flange **46**. When attaching the syringe **12** to the mounting assembly **14**, if the syringe **12** is rotated after the tabs **30** engage the distal ledge, a sensor **50** is provided in the annular surface **28** to read the encoding device **48**. The sensor **50** then forwards the associated signals to the injector controller **51**, which interprets the signals and modifies the function of the injector **20** accordingly. Examples of the information which could be encoded on the encoding device **48** include dimensions of the syringe **12**, volume of the syringe **12**, content of the syringe **12** (in the case of a pre-filled syringe), manufacturing information such as lot numbers, dates and tool cavity number, recommended contrast media flow rates and pressures, and loading/injection sequences.

[0010] As an alternative to the encoding device 48 being a bar code, the encoding device 48 also could include machine-readable raised or recessed surfaces. In addition, the tubular body 32 of the syringe 12 also may be provided with an indicating mechanism 52 for readily detecting the presence or absence of a liquid contrast media in the syringe 12. In this instance, the indicating mechanism 52 includes a plurality of integrally molded, textured dots on the syringe 12, which provide a visual indication of whether the syringe 12 contains liquid or air.

[0011] Accordingly, while the above injector and syringe apparatus have proven effective, the engagement reliability of the mounting assembly 14 discussed hereinabove was found to be insufficient. Accordingly, a need has arisen for a more reliable syringe/injector engagement interface.

SUMMARY

[0012] According to one aspect of the device of the present disclosure, provided is an injector system for injecting fluid that includes a syringe and an injector. The syringe includes: a body comprising a rearward end and a forward end; a plunger movably disposed within the body; at least one syringe drive paw positioned toward the rearward end of the body; and a syringe engagement flange positioned toward the rearward end of the body and extending around a circumference of the body. The injector includes: a housing having a front plate defining a syringe-receiving opening therein and a drive member at least partially disposed within the housing and operable to engage the plunger disposed within the syringe. The syringe latch has a plurality of latch members extending toward a center of the syringe-receiving opening and configured to move from a closed position to an open position when a force is applied thereto and from the open position to the closed position when the force is removed therefrom. The syringe engagement flange pushes against the plurality of latch members of the syringe latch to open the syringe latch as axial rearward motion is applied to the syringe relative to the syringe latch and the plurality of latch members return to the closed position to retain the syringe within the opening of the housing when the syringe is fully seated within the housing.

[0013] The injector may further include a syringe release gear that forms an enclosure for receiving the syringe when the syringe is fully seated within the housing. The syringe release gear may be mounted to a rear side of the front plate by at least one syringe release cam pin. The syringe release gear may also include an opening formed therein that is aligned with the syringe-receiving opening of the front plate. The opening in the syringe release gear may include a plurality of teeth formed around a circumference thereof. In addition, the syringe

drive paw may be configured to engage the plurality of teeth of the opening of the syringe release gear.

[0014] The syringe may be disengaged from the injector after completion of an injection procedure by rotating the syringe. This causes rotation of the syringe release gear via the engagement between the syringe drive paw and the plurality of teeth of the syringe release gear. The plurality of latch members of the syringe latch are thereby forced into the open position which allows a user to remove the syringe from the housing of the injector. The syringe desirably includes two syringe drive paws that are positioned toward the rearward end of the body located 180° degrees apart

[0015] The syringe latch may include two latch members, three latch members, or any other suitable number of latch members. Each of the plurality of latch members of the syringe latch may include a first portion and an arc-shaped second portion extending from the first portion. The arc-shaped second portion, when viewed in cross-section, may include a sloping face. The syringe latch may be manufactured from a polymeric material.

[0016] According to another aspect of the present disclosure, also provided is a method for engaging a syringe with an injector. The method includes: providing a syringe having a body with a rearward end and a forward end, a plunger movably disposed within the body, a syringe drive paw positioned toward the rearward end of the body, and a syringe engagement flange positioned toward the rearward end of the body and extending around a circumference of the body; providing an injector that includes a housing having a front plate defining a syringe-receiving opening therein, a drive member at least partially disposed within the housing and operable to engage the plunger disposed within the syringe; and a syringe latch mounted to a front side of the front plate and comprising a plurality of latch members extending toward a center of the syringe-receiving opening and configured to move from a closed position to an open position when a force is applied thereto and from the open position to the closed position when the force is removed therefrom; applying axial rearward motion to the syringe relative to the syringe latch such that the syringe engagement flange pushes against the plurality of latch members of the syringe latch to open the syringe latch; and returning the plurality of latch members of the syringe latch to the closed position to retain the syringe within the opening of the housing when the syringe is fully seated within the housing.

[0017] According to another aspect of the present disclosure, an injector system for injecting fluid may include a syringe having a body comprising a rearward end and a forward

end, and a plunger movably disposed within the body, the plunger having at least one flexible leg extending toward the rearward end of the body. The injector system may further include an injector having

a housing having a front plate defining a syringe-receiving opening therein, a drive member at least partially disposed within the housing and operable to engage the plunger disposed within the syringe and releasably connect the at least one flexible leg to at least a portion of the drive member, a syringe release gear that forms an enclosure for receiving the syringe when the syringe is fully seated within the housing, the syringe release gear mounted to a rear side of the front plate, and a plunger release tube surrounding at least a portion of the drive member, the plunger release tube having a first end rotationally engaged with the syringe release gear. Rotation of the syringe release gear may rotate and axially move the plunger release tube relative to the drive member to engage the at least one flexible leg and release the at least one flexible leg from the drive member.

[0018] According to a further aspect of the present disclosure, the syringe release gear may be mounted to a rear side of the front plate by at least one syringe release cam pin. The syringe release cam pin may extend through the front plate. The syringe release gear may include an opening formed therein that is aligned with the syringe-receiving opening of the front plate. The opening in the syringe release gear may include a plurality of teeth formed around a circumference thereof. At least one syringe drive paw may be positioned toward the rearward end of the body and a syringe engagement flange may be positioned toward the rearward end of the body and extending around a circumference of the body. The injector may further include a syringe latch mounted to a front side of the front plate, the syringe latch comprising a plurality of latch members extending toward a center of the syringe-receiving opening and configured to move from a closed position to an open position when a force is applied thereto and from the open position to the closed position when the force is removed therefrom. The syringe engagement flange may push against the plurality of latch members of the syringe latch to open the syringe latch as axial rearward motion is applied to the syringe relative to the syringe latch and the plurality of latch members return to the closed position to retain the syringe within the opening of the housing when the syringe is fully seated within the housing. The syringe drive paw may be configured to engage a plurality of teeth formed on the syringe release gear. The syringe may be disengaged from the injector after completion of an injection procedure by rotating the syringe, which causes rotation of the syringe release gear via the engagement between the syringe drive paw and a plurality of

teeth of the syringe release gear, thereby forcing the plurality of latch members into the open position and allowing a user to remove the syringe from the housing of the injector. Each of the plurality of latch members of the syringe latch may include a first portion and an arc-shaped second portion extending from first portion. The arc-shaped portion may include a slot formed therein. The syringe may include two syringe drive paws positioned toward the rearward end of the body and located 180° degrees apart.

[0019] According to another aspect of the present disclosure, a front-loading medical injector system may include a syringe having a body comprising a rearward end and a frontward end, and a plunger movably disposed within the body, the plunger having at least one flexible leg extending toward the rearward end of the body. The injector system may further include an injector having a housing having a front plate defining a syringe-receiving opening therein, a drive member at least partially disposed within the housing and operable to engage the plunger disposed within the syringe and releasably connect the at least one flexible leg to at least a portion of the drive member, and a syringe release assembly operable to release the syringe. Rotation of the syringe release assembly may release the at least one flexible leg from the drive member. The syringe release assembly may include a syringe release gear that forms an enclosure for receiving the syringe when the syringe is fully seated within the housing, the syringe release gear mounted to a rear side of the front plate, and a plunger release tube surrounding at least a portion of the drive member, the plunger release tube having a first end rotationally engaged with the syringe release gear. Rotation of the syringe release gear may rotate and axially move the plunger release tube relative to the drive member to engage the at least one flexible leg and release the at least one flexible leg from the drive member. The injector may further include a syringe latch mounted to a front side of the front plate for securing the syringe to the injector. The syringe latch may have a plurality of latch members extending toward a center of the syringe-receiving opening and configured to move from a closed position to an open position when a force is applied thereto and from the open position to the closed position when the force is removed therefrom. At least one syringe drive paw may be positioned toward the rearward end of the body, and a syringe engagement flange may be positioned toward the rearward end of the body and extending around a circumference of the body. The syringe engagement flange may push against the plurality of latch members of the syringe latch to open the syringe latch as axial rearward motion is applied to the syringe relative to the syringe latch and the plurality of latch members return to the closed position to retain the syringe within the opening of the housing

when the syringe is fully seated within the housing. Each of the plurality of latch members of the syringe latch may include a first portion and an arc-shaped second portion extending from first portion.

[0020] These and other features and characteristics of the device of the present disclosure, as well as the methods of operation and functions of the related elements of structures and the combination of parts and economies of manufacture, will become more apparent upon consideration of the following description and the appended claims with reference to the accompanying drawings, all of which form a part of this specification, wherein like reference numerals designate corresponding parts in the various figures. It is to be expressly understood, however, that the drawings are for the purpose of illustration and description only and are not intended as a definition of the limits of the device of the present disclosure. As used in the specification and the claims, the singular form of “a”, “an”, and “the” include plural referents unless the context clearly dictates otherwise.

BRIEF DESCRIPTION OF THE DRAWINGS

[0021] **FIG. 1** is a perspective view of a conventional injector system showing an injector housing and a syringe in a disassembled relationship;

[0022] **FIG. 2** is a cross-sectional view of an injector system in accordance with an embodiment of the disclosure showing the syringe and the injector housing in a partially disassembled relationship;

[0023] **FIG. 3** is a top plan view of the syringe latch in accordance with an embodiment of the disclosure for connecting the syringe to the injector housing;

[0024] **FIGS. 4A-4E** are cross-sectional views of a portion of the injector system of **FIG. 2** illustrating the steps required for loading a syringe into the injector housing;

[0025] **FIG. 5** is a cross-sectional view of the injector system of **FIG. 2** showing the syringe and the injector housing in the assembled state;

[0026] **FIG. 6** is a cross-sectional view of the injector system of **FIG. 2** taken along line **B-B**;

[0027] **FIG. 7** is a cross-sectional view of the injector system of **FIG. 2** taken along line **A--A**;

[0028] **FIGS. 8A-8D** are cross-sectional views of a portion of the injector system of **FIG. 5** illustrating the steps required for unloading a syringe from the injector housing;

[0029] **FIG. 9** is a perspective view of an injector in accordance with an alternative embodiment of the disclosure;

[0030] **FIG. 10** is a perspective view of the injector of **FIG. 9** having the faceplate removed such that an alternative embodiment of the syringe latch is visible;

[0031] **FIG. 11** is a perspective view of the injector of **FIG. 10** with syringes attached thereto;

[0032] **FIG. 12** is a perspective view of the injector of **FIG. 9** with syringes attached thereto;

[0033] **FIG. 13** is a side view of a syringe configured to be used with the injector of **FIG. 9**; and

[0034] **FIG. 14** is are front views of the syringe latch of the injector of **FIG. 9**.

DETAILED DESCRIPTION

[0035] For purposes of the description hereinafter, the terms “upper”, “lower”, “right”, “left”, “vertical”, “horizontal”, “top”, “bottom”, “lateral”, “longitudinal”, and derivatives thereof, shall relate to the device of the present disclosure as it is oriented in the drawing figures. However, it is to be understood that the device of the present disclosure may assume various alternative variations, except where expressly specified to the contrary. It is also to be understood that the specific devices illustrated in the attached drawings, and described in the following specification, are simply exemplary embodiments of the device of the present disclosure. Hence, specific dimensions and other physical characteristics related to the embodiments disclosed herein are not to be considered as limiting.

[0036] With reference to **FIG. 2**, an injector system **100** for injecting a liquid contrast media into a vascular system of an animal is provided. The injector system **100** has a front-loading construction. The system of **FIG. 2** utilizes a syringe **102** capable of being front-loaded into a mounting assembly **104** associated with a front plate **106** of a housing (not shown) of an injector **108** by a first releasable mechanism **22**. The syringe **102** is capable of functioning in an injection operation without the use of a pressure jacket (although the syringe may be used in an injector with a pressure jacket).

[0037] The syringe **102** includes an elongated main tubular body or barrel **110** and a coaxial discharge injection section **112** interconnected by an intermediate conical portion **114**. A plunger **116** is slidably positioned within the tubular body **110** and includes at least one plunger connect flex leg **118** that is connectable to a piston/plunger interface **120** on a piston **122** of the injector **108**. The plunger **116** also includes a plunger sense interrupter **123**

extending from a central portion thereof in the direction of the at least one flex leg **118**. The plunger sense interrupter **123** is configured to interrupt a light path produced by an IR transmitter **140** and IR receiver **142** through a fiber optic cable **144** extending along the length of the piston **122**, thereby providing a signal to an injector controller (not shown) that the syringe **102** is fully seated within the injector **108**. An alternative embodiment of the plunger sense interrupter **123** determines the presence/absence of the syringe **102** without the use of a fiber optic cable.

[0038] The syringe **102** further includes a syringe engagement flange **124** positioned toward the rearward end of the body **110** and extending around a circumference of the body **110**. When viewed in cross-section, the syringe engagement flange **124** includes a sloping section **126**, a shoulder section **128** extending from the sloping section **126** that is essentially perpendicular to an exterior surface of the body **110** of the syringe **102**, and an engagement section **130** extending from the shoulder section **128**. The engagement section **130** is configured to engage a plurality of teeth **132** of an opening **134** of a syringe release gear **136** of the injector **108** as discussed in greater detail hereinafter in relation to **FIG. 6**.

[0039] Since the syringe **102** is being used in this embodiment without a pressure jacket, for strength and visibility of the contents of the syringe **102**, the syringe **102** may be formed of a clear PET polyester material. In the alternative, the wall of the syringe **102** may be formed of polypropylene reinforced by providing a series of annular ribs on the tubular body **110** of the syringe **102** in a longitudinally spaced relationship. In addition, the syringe **102** desirably includes an encoding device for providing information regarding the syringe **102** to the injector **108** an indicating mechanism for readily detecting the presence or absence of a liquid contrast media in the syringe **102** similar to the encoding device and indicating mechanism of syringe **12** discussed hereinabove.

[0040] With continued reference to **FIG. 1**, the injector includes a housing (not shown) having the front plate **106** defining a syringe-receiving opening **138** therein. The piston **122** is positioned within the housing and is configured to extending into and out of the syringe-receiving opening **138** under the power of a drive mechanism **146**. The piston **122** includes the piston/plunger interface **120** at an end thereof that is operable to interact with the at least one flex leg **118** of the plunger **116** to engage the plunger **116** disposed within the syringe **102**.

[0041] With reference to **FIG. 3** and with continuing reference to **FIG. 2**, the injector **108** also includes a syringe latch **148** mounted to a front side of the front plate **106** by any suitable

fastening device **150** for maintaining the syringe in the seated position within the injector **108**. The syringe latch **148** comprises a substantially oval shaped body member **152** and a plurality of latch members **154** extending toward a center **C** of the body member **152**. In the embodiment of the syringe latch **148** illustrated in **FIG. 3**, two latch members **154** are included. The syringe latch **148** is desirably manufactured from a resilient, polymeric material such that the latch members **154** are configured to move from a closed position to an open position when a force is applied thereto and from the open position to the closed position when the force is removed therefrom.

[0042] Each of the plurality of latch members **154** of the syringe latch **148** includes a first portion **156** extending from the body member **152** and an arc-shaped second portion **158** extending from the first portion **156** and configured to engage the syringe engagement flange **124** of the syringe **102**. The arc-shaped second portion **158**, when viewed in cross-section, may include a sloping face **160** (see **FIGS. 4A-4E**) that engages with the sloping section **126** of the syringe engagement flange **124** to force the syringe latch **148** into the open position.

[0043] With continued reference to **FIG. 2**, the injector **108** also includes the syringe release gear **136** that forms an enclosure **162** for receiving the syringe **102** when the syringe **102** is fully seated within the injector housing. The syringe release gear **136** is mounted to a rear side of the front plate **106** by at least one syringe release cam pin **164**. The syringe release cam pin **164** is configured to be connected to the syringe release gear **136** and extend through the front plate **106** of the injector **108** into a slot **166** in the arc-shaped second portion **158** of the latch members **154** of the syringe latch **148**.

[0044] With reference to **FIG. 7** and with continued reference to **FIG. 2**, the piston **122** is surrounded by a plunger release tube **168**. The plunger release tube **168** has a first end that is rotationally engaged with the syringe release gear **136** such that rotation of the syringe release gear **136** causes rotation of the plunger release tube **168**.

[0045] The process for engaging a syringe **102** with the injector **108** to form an injector system **100** is illustrated in **FIGS. 4A-4E**. This process allows for syringe engagement with an injector **108** that provides a syringe engagement adapted to releasably engage the syringe **102** with the injector **108** regardless of the rotational orientation of the syringe **102** with respect to the injector **108**. The syringe engagement uses the flex legs **118** attached to the back side of the plunger **116** of the syringe **102** and a corresponding feature on the piston **122** of an injector **108** that provides axial engagement that does not require any specific rotational orientation of the syringe **102** to releasably engage with the injector **108**. Additionally, a

feature (i.e., the syringe engagement flange **124**) is provided on the outside surface of the rear portion of the tubular body **110** to transfer rotational movement of the syringe into a release mechanism (i.e., the syringe release gear **136**) implemented in the injector **108** releasing both the syringe **102** and the plunger **116** regardless of the axial position of the engaged syringe plunger **116**.

[0046] The first step in the process for engaging the syringe **102** with the injector **108** is shown in **FIG. 4A** in which the syringe **102** is positioned axially with the syringe-receiving opening **134** of the front plate **106** of the injector **108** and is moved axially along the piston **122** into the enclosure **162** formed by the syringe release gear **136** in the direction of arrow **A₁**. With reference to **FIG. 4B**, as the syringe **102** is inserted, the sloping section **126** of the syringe engagement flange **124** engages the sloping face **160** of the arc-shaped second section **158** of the latch members **154** of the syringe latch **148** and pushes the syringe latch **148**. In addition, with reference to **FIGS. 4C** and **4D**, as the syringe **102** is inserted, the sloped surface of the piston/plunger interface **120** flexes the at least one flex leg **118** of the plunger **116** open. With reference to **FIG. 4E**, continual movement of the syringe **102** in the direction of arrow **A₁** causes the syringe **102** to be fully seated within the enclosure **162** formed by the syringe release gear **136**. When the body of the syringe **102** is fully seated within the enclosure **162** formed by the syringe release gear **136**, the following items occur: first, the engagement section **130** of the syringe engagement flange **124** engages the teeth **132** of the syringe release gear **136**. In addition, the syringe engagement flange **124** moves beyond the arc-shaped second portion **158** of the latch members **154** of the syringe latch **148**, thereby closing the syringe latch **148** to retain the syringe **102**. Desirably, when the syringe latch **148** returns to the closed position, it provides an audible “click” to indicate to the operator that the syringe **102** has been installed on the injector **108**. Furthermore, the flex legs **118** on the plunger **116** flex closed engaging the piston/plunger interface **120**. Finally, the plunger sense interrupter **123** of the plunger **116** interrupts the light path produced by an IR transmitter **140** and IR receiver **142** through a fiber optic cable **144** extending along the length of the piston **122**, thereby providing a signal to an injector controller (not shown) that the syringe **102** is fully seated within the injector **108**.

[0047] Removal of the syringe **102** from the injector **108** upon the completion of an injection procedure requires that the syringe **102** be rotated, as described below. This operation is illustrated in and described by reference to **FIGS. 8A-8D**.

[0048] With reference to **FIG. 8A** and **FIG. 8B**, the rotation of the syringe **102** causes rotation of the syringe release gear **136** via the engagement between the engagement section **130** of the syringe engagement flange **124** and the plurality of teeth **132** of the syringe release gear **136** as shown in **FIG. 6**. This rotation, in turn, causes rotation of the syringe release cam pins **164** along the slots **166** provided in the latch members **154** of the syringe latch **148** as shown in **FIG. 8C**. The latch members **154** of the syringe latch **148** are thereby forced into the open position.

[0049] As also shown in **FIG. 8C**, the rotation of the syringe release gear **136** also rotates the plunger release tube **168** about the piston **122** since the plunger release tube **168** is coupled to the syringe release gear **136** as described hereinabove. The rotation of the plunger release tube **168** about the piston **122** causes a cam action at a release cam surface **170** (see **FIGS. 1** and **5**) causing an axial extension of the plunger release tube **168** towards the syringe-receiving opening **134** of the front plate **106**. The axial extension of the plunger release tube **168** forces the at least one flex leg **118** of the plunger **116** to flex open to release the piston/plunger interface **122**.

[0050] At this point, a user can remove the syringe **102** from the housing of the injector **108**. Once the syringe **102** is removed, the syringe release gear **136** returns to original position allowing the syringe latch **148** to return to the closed position and the plunger release tube **168** to drop down as shown in **FIG. 8D**.

[0051] While the syringe latch **148** discussed hereinabove includes two latch members, this is not to be construed as limiting the disclosure as any suitable number of latch members may be utilized. For instance, with reference to **FIGS. 9-14**, the injector may be embodied as a dual syringe injector system **200** that includes a pair of syringes **202a**, **202b** and an injector **204**. As shown in **FIGS. 10** and **11**, the injector **204** utilizes a syringe latch **206a**, **206b** for each of the syringes **202a**, **202b** that includes three latch members **208** for engaging the syringe **202a**, **202b** within the injector **204**. In addition, rather than having the latch members **208** connected to a body member as with the syringe latch **148** discussed hereinabove, each of the latch members **208** is independent and utilizes a spring return **210** (see **FIG. 14**).

[0052] More specifically, with reference to **FIGS. 13** and **14**, a syringe **202a**, **202b** for use with injector **204** includes a body **212** comprising a rearward end **214** and a forward end **216**; a plunger (not shown) movably disposed within the body **212**; and at least one syringe drive paw **218** positioned toward the rearward end **214** of the body **216**. Desirably, the syringe **202a**, **202b** includes a pair of syringe drive paws **218** at the rearward end **214** of the body **216**

located 180° apart. The syringe **202a, 202b** also includes a syringe engagement flange **220** positioned toward the rearward end **214** of the body **212** and extending around a circumference of the body **212**.

[0053] The injector **204** includes a pair of syringe latches **206a, 206b** mounted to a front side of the front plate thereof. Each of the syringe latches **206a, 206b** comprises a plurality of latch members **208** extending toward a center of the syringe-receiving opening **222** and configured to move from a closed position to an open position when a force is applied thereto and from the open position to the closed position when the force is removed therefrom. The syringe engagement flange **220** pushes against the plurality of latch members **208** of the syringe latch **206a, 206b** to open the syringe latch **206a, 206b** as axial rearward motion is applied to the syringe **202a, 202b** relative to the syringe latch **206a, 206b** and the plurality of latch members **208** return to the closed position to retain the syringe **202a, 202b** within the opening **222** of the injector **204** when the syringe **202a, 202b** is fully seated within the injector **204**.

[0054] The syringe **202a, 202b** may be disengaged from the injector **204** after completion of an injection procedure by rotating the syringe **202a, 202b**. This causes rotation of a syringe release gear **224** via the engagement between the syringe drive paws **218** and a plurality of teeth of the syringe release gear **224**. The rotation of the syringe release gear **224** activates the spring returns **210**, which force the latch members **208** of the syringe latch **206a, 206b** into the open position, thereby allowing a user to remove the syringe **202a, 202b** from the injector **204**.

[0055] While specific embodiments of the device of the present disclosure have been described in detail, it will be appreciated by those skilled in the art that various modifications and alternatives to those details could be developed in light of the overall teachings of the disclosure. Accordingly, the particular arrangements disclosed are meant to be illustrative only and not limiting as to the scope of the device of the present disclosure which is to be given the full breadth of the claims appended and any and all equivalents thereof.

WE CLAIM:

1. An injector system for injecting fluid comprising:

a syringe comprising:

a body comprising a rearward end and a forward end;

a plunger movably disposed within the body, the plunger having at least one flexible leg extending toward the rearward end of the body; and

an injector comprising:

a housing having a front plate defining a syringe-receiving opening therein;

a drive member at least partially disposed within the housing and operable to engage the plunger disposed within the syringe and releasably connect the at least one flexible leg to at least a portion of the drive member;

a syringe release gear that forms an enclosure for receiving the syringe when the syringe is fully seated within the housing, the syringe release gear mounted to a rear side of the front plate; and

a plunger release tube surrounding at least a portion of the drive member, the plunger release tube having a first end rotationally engaged with the syringe release gear,

wherein rotation of the syringe release gear rotates and axially moves the plunger release tube relative to the drive member to engage the at least one flexible leg and release the at least one flexible leg from the drive member.

2. The injector system of claim 1, wherein the syringe release gear is mounted to a rear side of the front plate by at least one syringe release cam pin.

3. The injector system of claim 2, wherein syringe release cam pin extends through the front plate.

4. The injector system of claim 1, wherein the syringe release gear includes an opening formed therein that is aligned with the syringe-receiving opening of the front plate.

5. The injector system of claim 4, wherein the opening in the syringe release gear includes a plurality of teeth formed around a circumference thereof.

6. The injector system of claim 1, further comprising at least one syringe drive paw positioned toward the rearward end of the body; and

a syringe engagement flange positioned toward the rearward end of the body and extending around a circumference of the body.

7. The injector system of claim 6, further comprising a syringe latch mounted to a front side of the front plate, the syringe latch comprising a plurality of latch members extending toward a center of the syringe-receiving opening and configured to move from a closed position to an open position when a force is applied thereto and from the open position to the closed position when the force is removed therefrom,

wherein the syringe engagement flange pushes against the plurality of latch members of the syringe latch to open the syringe latch as axial rearward motion is applied to the syringe relative to the syringe latch and the plurality of latch members return to the closed position to retain the syringe within the opening of the housing when the syringe is fully seated within the housing.

8. The injector system of claim 6, wherein the syringe drive paw is configured to engage a plurality of teeth formed on the syringe release gear.

9. The injector system of claim 6, wherein the syringe is disengaged from the injector after completion of an injection procedure by rotating the syringe, which causes

rotation of the syringe release gear via the engagement between the syringe drive paw and a plurality of teeth of the syringe release gear, thereby forcing the plurality of latch members into the open position and allowing a user to remove the syringe from the housing of the injector.

10. The injector system of claim 7, wherein each of the plurality of latch members of the syringe latch includes a first portion and an arc-shaped second portion extending from the first portion.

11. The injector system of claim 10, wherein the arc-shaped portion includes a slot formed therein.

12. The injector system of claim 1, wherein the syringe includes two syringe drive paws positioned toward the rearward end of the body and located 180° degrees apart.

13. A front-loading medical injector system comprising:

a syringe comprising:

a body comprising a rearward end and a frontward end;

a plunger movably disposed within the body, the plunger having at least one flexible leg extending toward the rearward end of the body; and

an injector comprising:

a housing having a front plate defining a syringe-receiving opening therein;

a drive member at least partially disposed within the housing and operable to engage the plunger disposed within the syringe and releasably connect the at least one flexible leg to at least a portion of the drive member; and

a syringe release assembly operable to release the syringe,

wherein rotation of the syringe release assembly releases the at least one flexible leg from the drive member.

14. The front-loading medical injector system of claim 13, wherein the syringe release assembly comprises:

a syringe release gear that forms an enclosure for receiving the syringe when the syringe is fully seated within the housing, the syringe release gear mounted to a rear side of the front plate; and

a plunger release tube surrounding at least a portion of the drive member, the plunger release tube having a first end rotationally engaged with the syringe release gear.

15. The front-loading medical injector system of claim 14, wherein rotation of the syringe release gear rotates and axially moves the plunger release tube relative to the drive member to engage the at least one flexible leg and release the at least one flexible leg from the drive member.

16. The front-loading medical injector system of claim 14, further comprising a syringe latch mounted to a front side of the front plate for securing the syringe to the injector, wherein the syringe latch comprises a plurality of latch members extending toward a center of the syringe-receiving opening and configured to move from a closed position to an open position when a force is applied thereto and from the open position to the closed position when the force is removed therefrom.

17. The front-loading medical injector system of claim 16, further comprising at least one syringe drive paw positioned toward the rearward end of the body; and

a syringe engagement flange positioned toward the rearward end of the body and extending around a circumference of the body.

18. The injector system of claim 17, wherein the syringe engagement flange pushes against the plurality of latch members of the syringe latch to open the syringe latch as axial rearward motion is applied to the syringe relative to the syringe latch and the plurality of latch members return to the closed position to retain the syringe within the opening of the housing when the syringe is fully seated within the housing.

19. The front-loading medical injector system of claim 16, wherein each of the plurality of latch members of the syringe latch includes a first portion and an arc-shaped second portion extending from the first portion.

20. A method for engaging a syringe with an injector, comprising:

providing a syringe comprising:

a body comprising a rearward end and a forward end;

a plunger movably disposed within the body, the plunger having at least one flexible leg extending toward the rearward end of the body;

providing an injector comprising:

a housing having a front plate defining a syringe-receiving opening therein;

a drive member at least partially disposed within the housing and operable to engage the plunger disposed within the syringe and releasably connect the at least one flexible leg to at least a portion of the drive member; and

a syringe latch mounted to a front side of the front plate, the syringe latch comprising a plurality of latch members extending toward a center of the syringe-receiving opening and configured to move from a closed position to an open position when a force is applied thereto and from the open position to the closed position when the force is removed therefrom;

applying axial rearward motion to the syringe relative to the syringe latch such that the syringe engagement flange pushes against the plurality of latch members of the syringe latch to open the syringe latch; and

returning the plurality of latch members of the syringe latch to the closed position to retain the syringe within the opening of the housing when the syringe is fully seated within the housing.

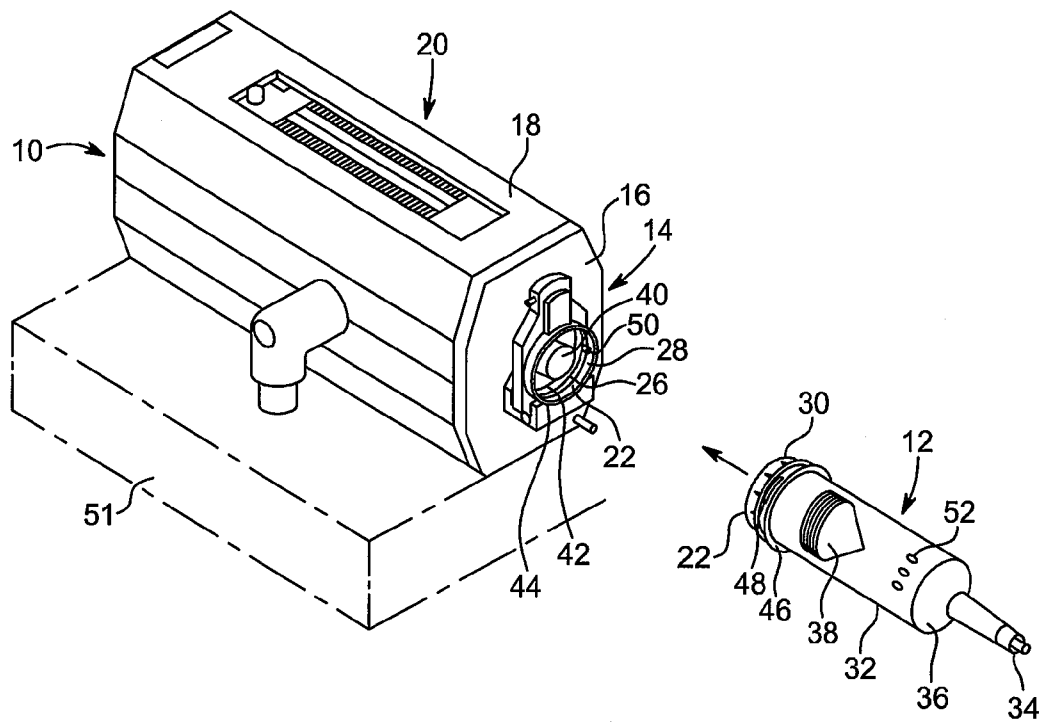

FIG. 1
PRIOR ART

2/13

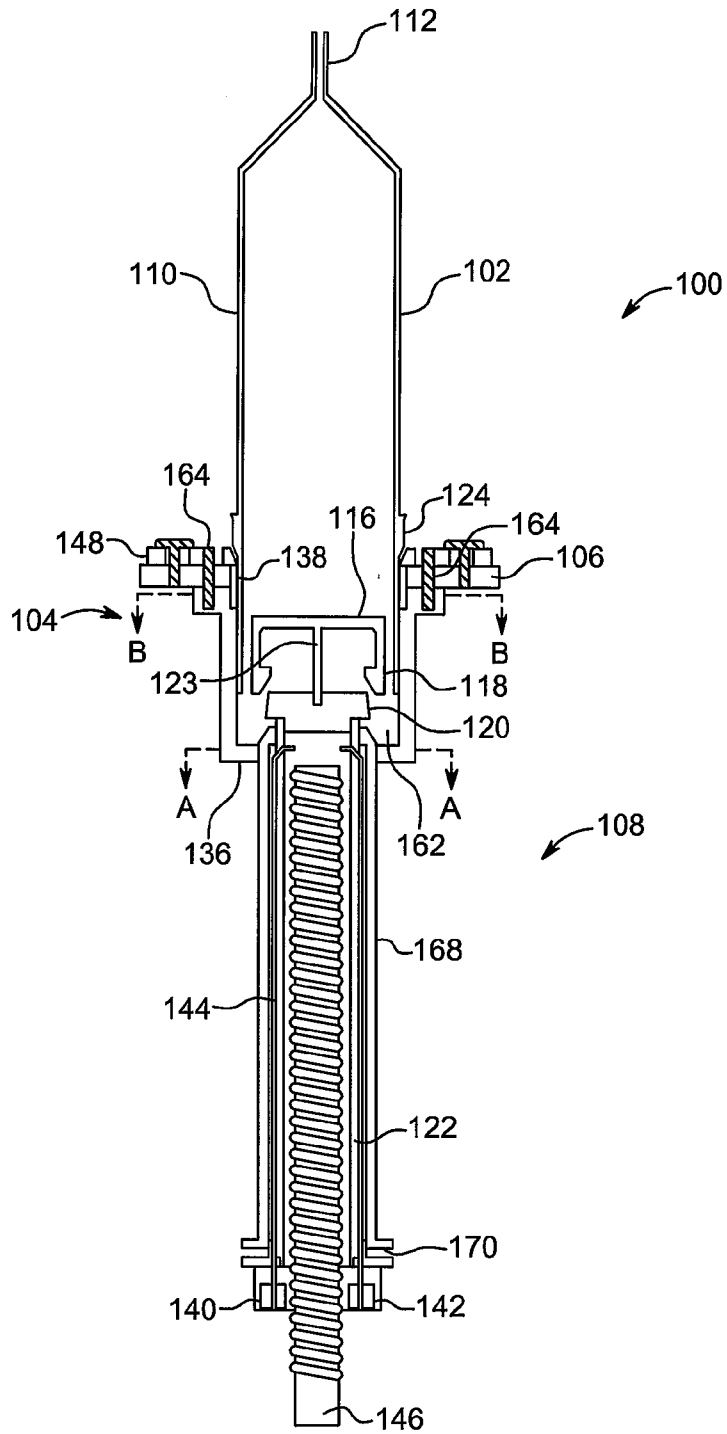

FIG. 2

3/13

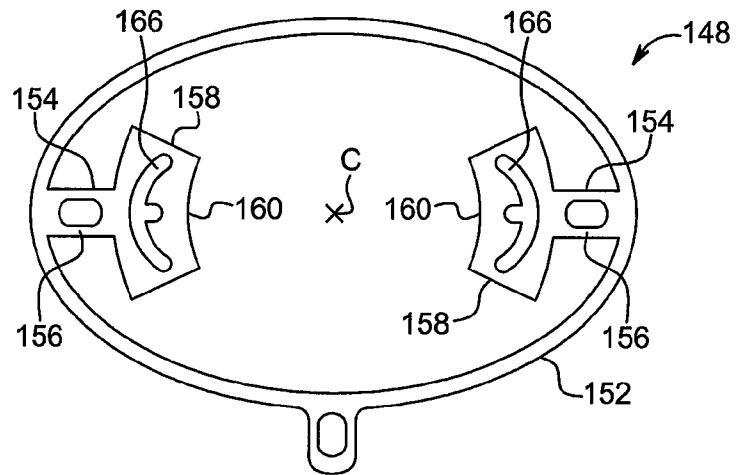

FIG. 3

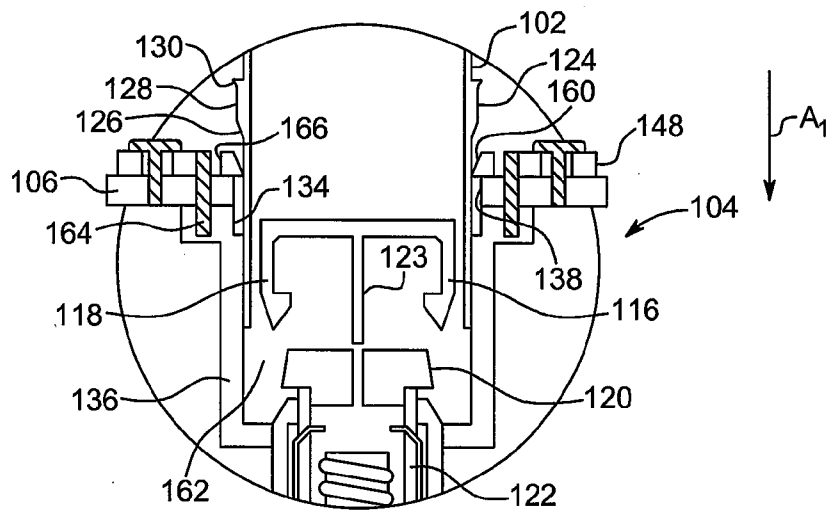

FIG. 4A

4/13

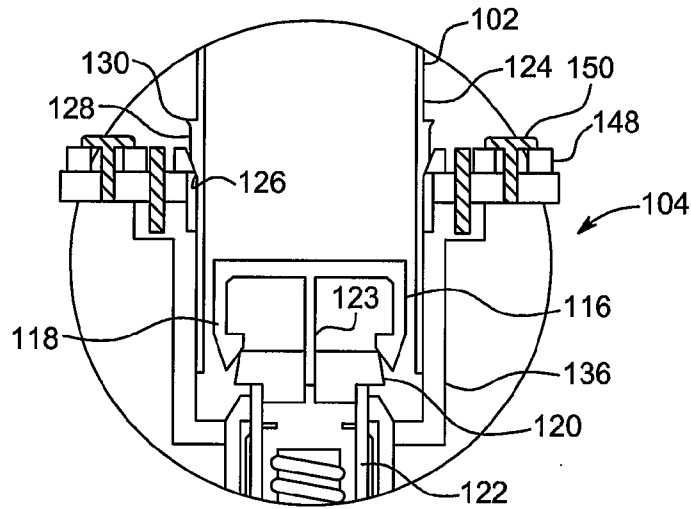

FIG. 4B

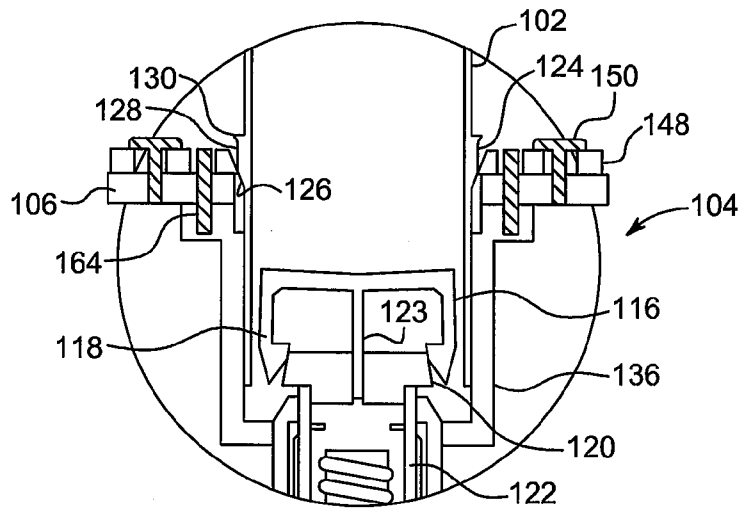

FIG. 4C

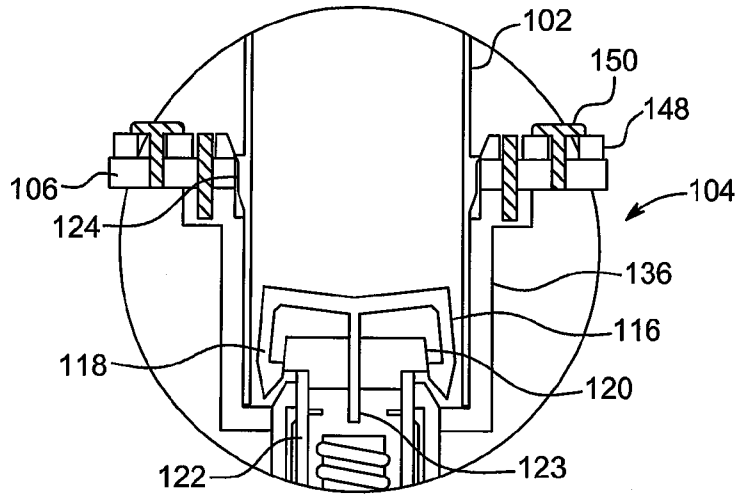

FIG. 4D

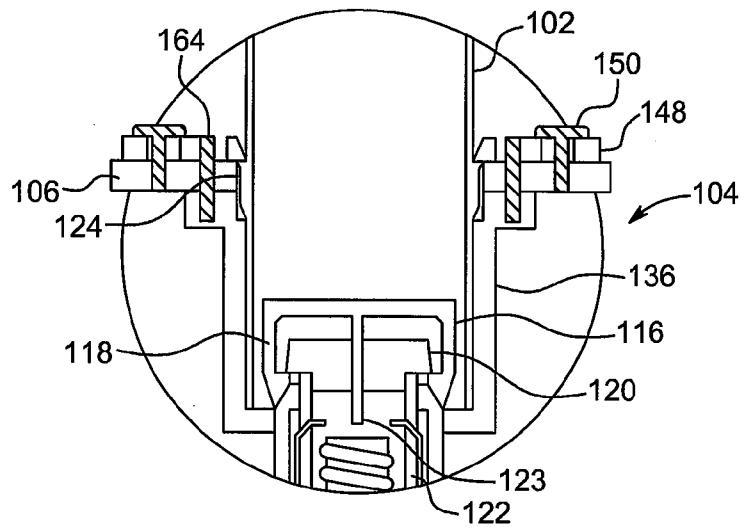

FIG. 4E

6/13

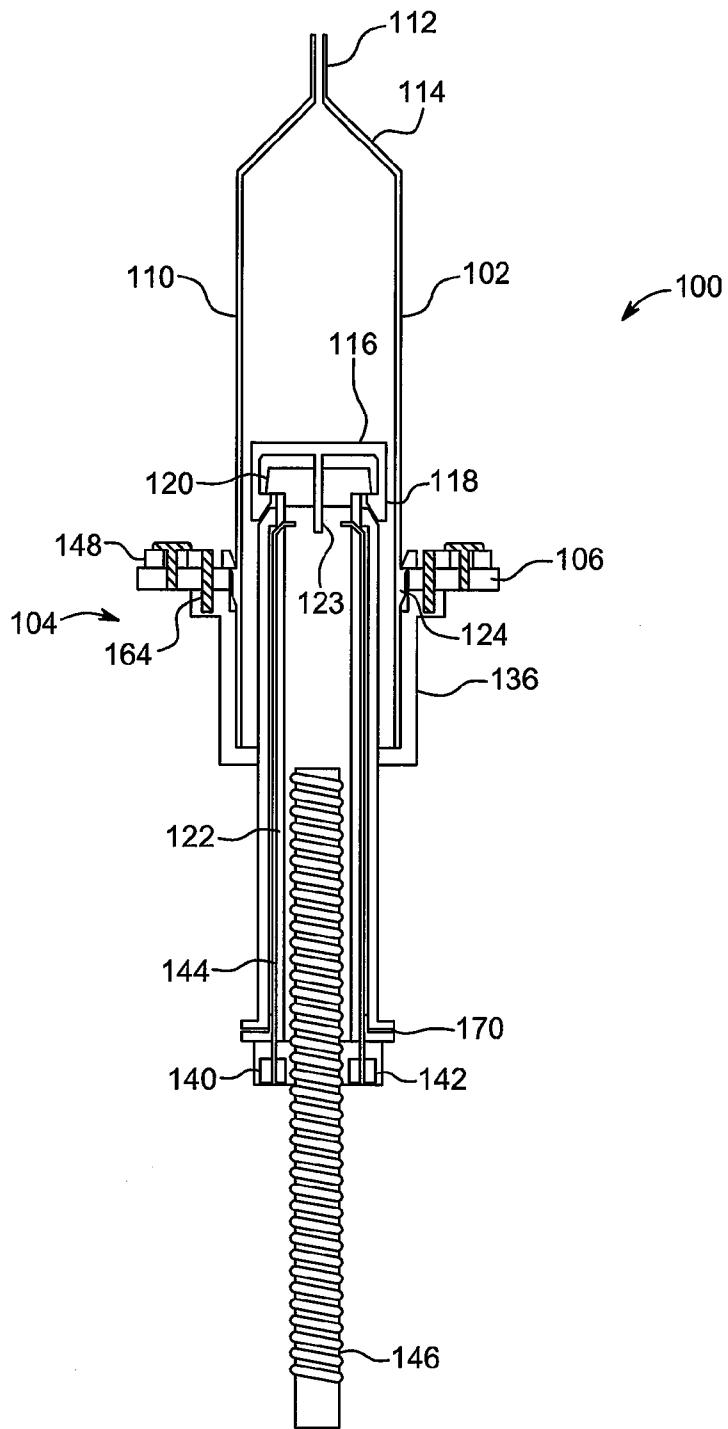

FIG. 5

7/13

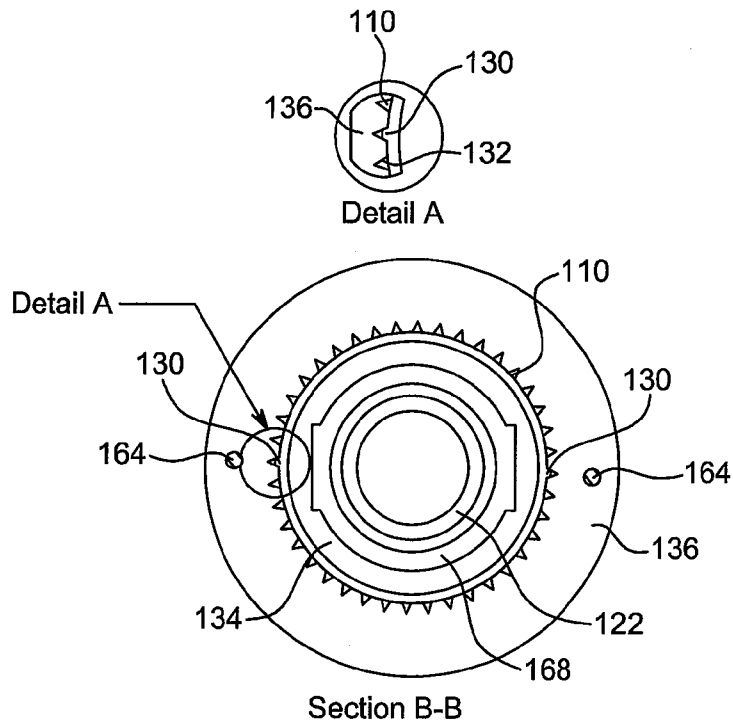

FIG. 6

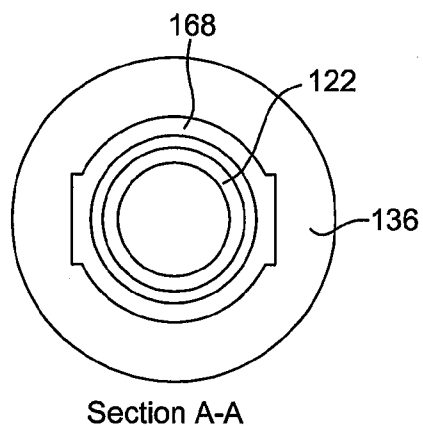

FIG. 7

8/13

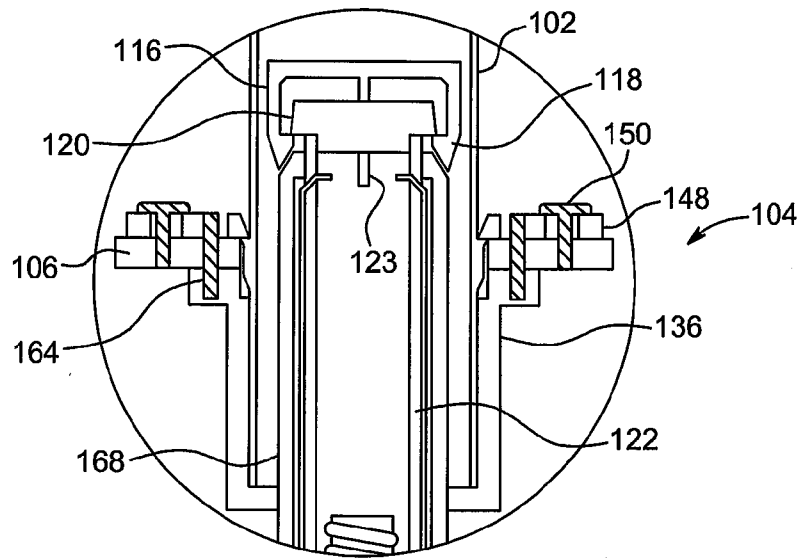

FIG. 8A

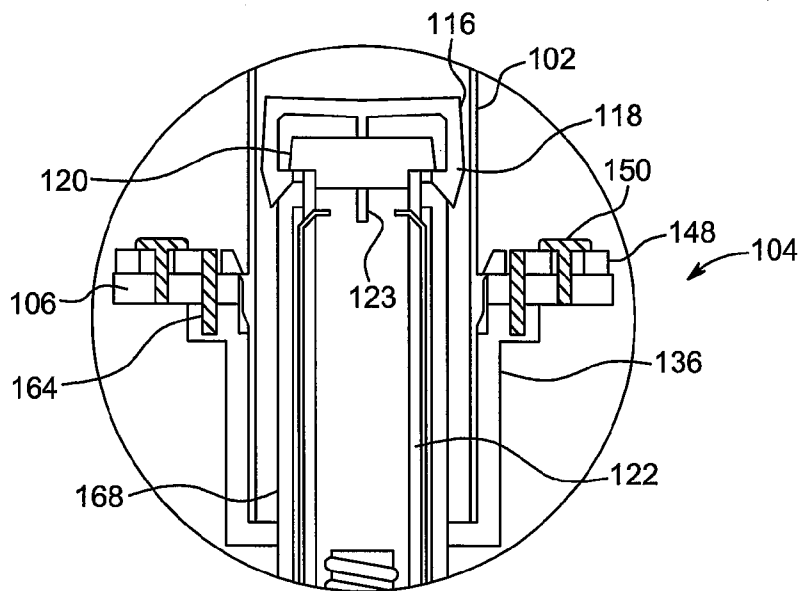

FIG. 8B

9/13

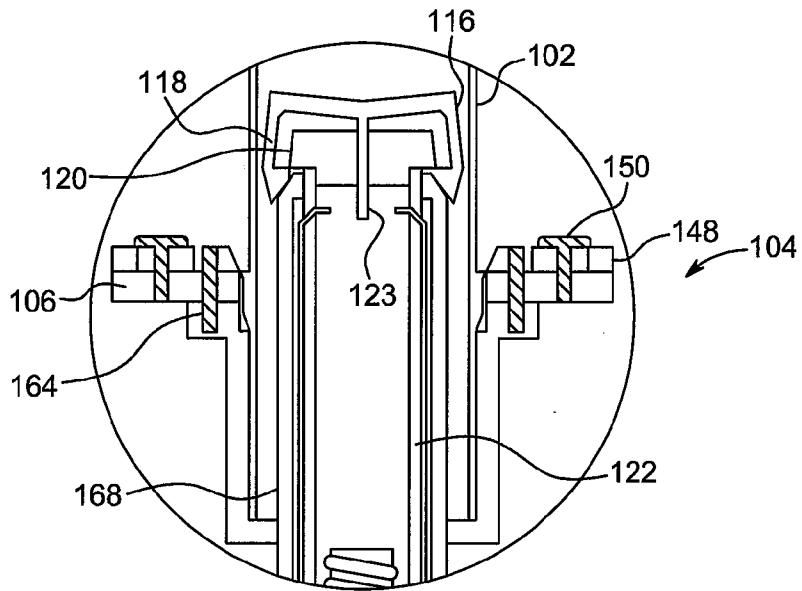

FIG. 8C

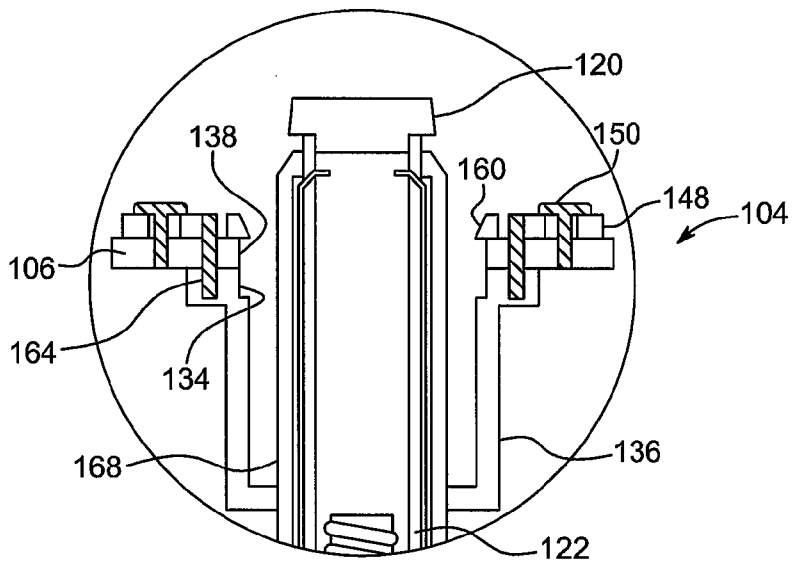

FIG. 8D

10/13

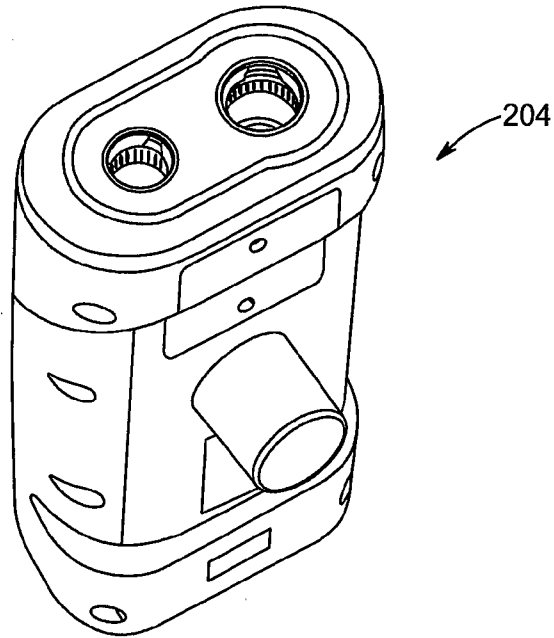

FIG. 9

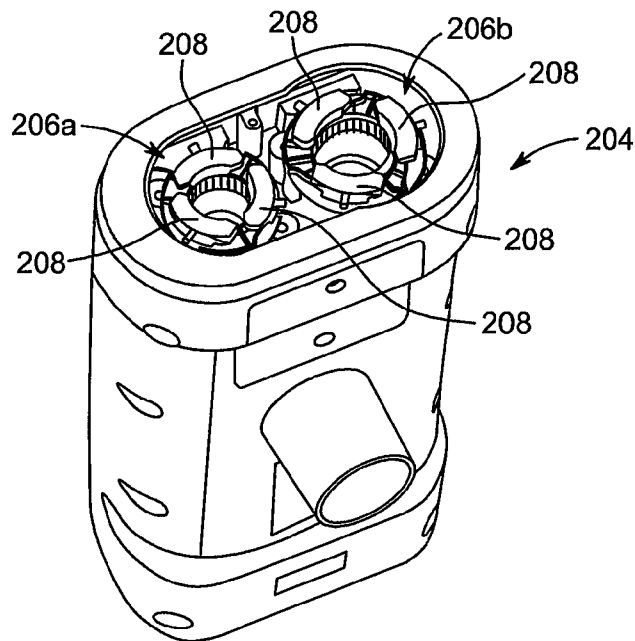

FIG. 10

11/13

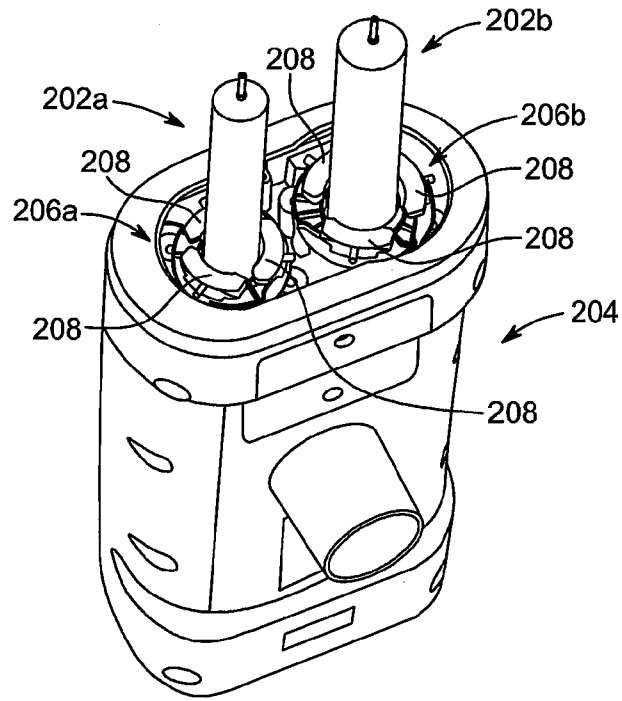

FIG. 11

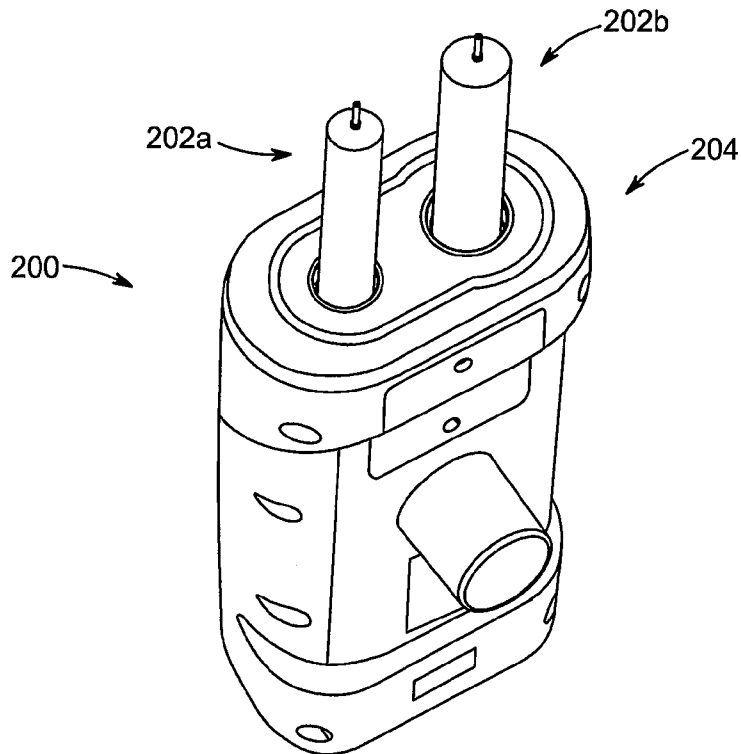

FIG. 12

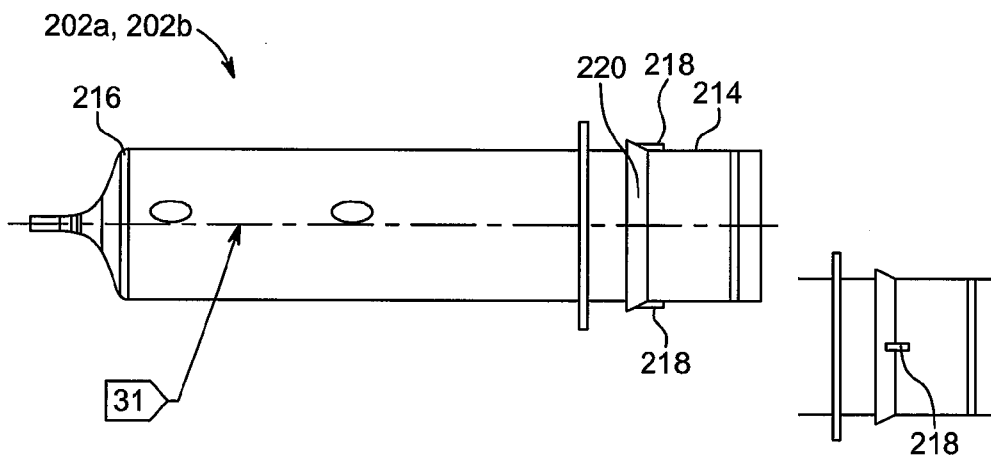

FIG. 13

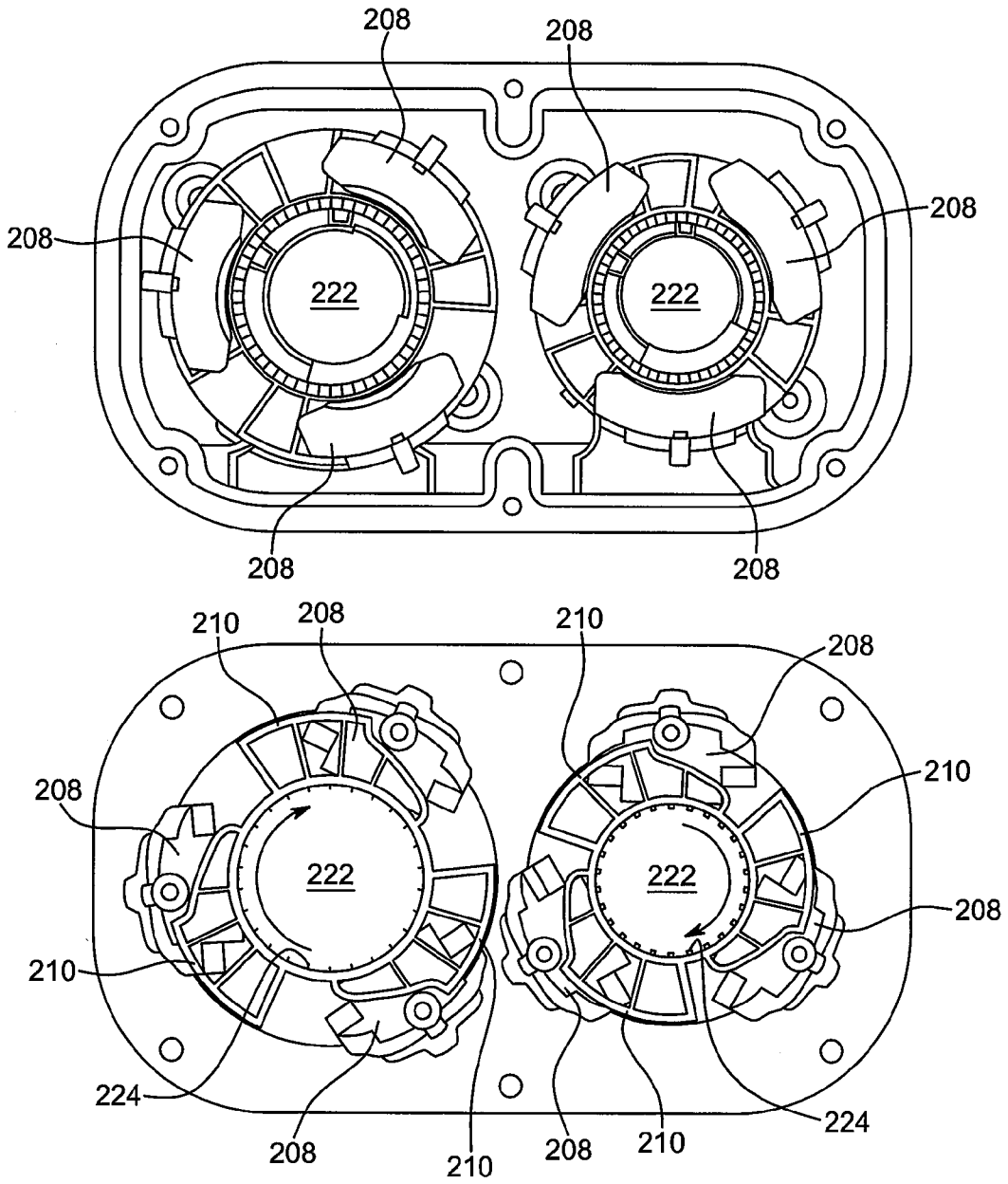

FIG. 14

INTERNATIONAL SEARCH REPORT

International application No.

PCT/US2015/021171

<p>A. CLASSIFICATION OF SUBJECT MATTER IPC(8) - A61M 5/315 (2015.01) CPC - A61M 5/31515 (2015.05) According to International Patent Classification (IPC) or to both national classification and IPC</p>																				
<p>B. FIELDS SEARCHED</p> <p>Minimum documentation searched (classification system followed by classification symbols) IPC(8) - A61M 5/00, 5/142, 5/145, 5/178, 5/20, 5/315 (2015.01) CPC - A61M 5/14546, 5/1456, 5/14566, 5/1458, 5/315, 5/31511, 5/31515; Y10S 128/01 (2015.05)</p> <p>Documentation searched other than minimum documentation to the extent that such documents are included in the fields searched USPC - 604/131, 151, 152, 154, 155, 218, 228 (keyword delimited)</p> <p>Electronic data base consulted during the international search (name of data base and, where practicable, search terms used) PatBase, Google Patents, Google, Google Scholar, YouTube. Search terms used: bayer, medical, syringe, release, plunger, gear, rotation</p>																				
<p>C. DOCUMENTS CONSIDERED TO BE RELEVANT</p> <table border="1"> <thead> <tr> <th>Category*</th> <th>Citation of document, with indication, where appropriate, of the relevant passages</th> <th>Relevant to claim No.</th> </tr> </thead> <tbody> <tr> <td>Y</td> <td>US 4,677,980 A (REILLY et al) 07 July 1987 (07.07.1987) entire document</td> <td>13</td> </tr> <tr> <td>Y</td> <td>US 5,947,929 A (TRULL) 07 September 1999 (07.09.1999) entire document</td> <td>13, 20</td> </tr> <tr> <td>Y</td> <td>US 6,533,758 B1 (STAATS et al) 18 March 2003 (18.03.2003) entire document</td> <td>20</td> </tr> <tr> <td>A</td> <td>US 2009/0112087 A1 (FAGO) 30 April 2009 (30.04.2009) entire document</td> <td>1-20</td> </tr> <tr> <td>A</td> <td>US 2010/0222674 A1 (COWAN et al) 02 September 2010 (02.09.2010) entire document</td> <td>1-20</td> </tr> </tbody> </table>			Category*	Citation of document, with indication, where appropriate, of the relevant passages	Relevant to claim No.	Y	US 4,677,980 A (REILLY et al) 07 July 1987 (07.07.1987) entire document	13	Y	US 5,947,929 A (TRULL) 07 September 1999 (07.09.1999) entire document	13, 20	Y	US 6,533,758 B1 (STAATS et al) 18 March 2003 (18.03.2003) entire document	20	A	US 2009/0112087 A1 (FAGO) 30 April 2009 (30.04.2009) entire document	1-20	A	US 2010/0222674 A1 (COWAN et al) 02 September 2010 (02.09.2010) entire document	1-20
Category*	Citation of document, with indication, where appropriate, of the relevant passages	Relevant to claim No.																		
Y	US 4,677,980 A (REILLY et al) 07 July 1987 (07.07.1987) entire document	13																		
Y	US 5,947,929 A (TRULL) 07 September 1999 (07.09.1999) entire document	13, 20																		
Y	US 6,533,758 B1 (STAATS et al) 18 March 2003 (18.03.2003) entire document	20																		
A	US 2009/0112087 A1 (FAGO) 30 April 2009 (30.04.2009) entire document	1-20																		
A	US 2010/0222674 A1 (COWAN et al) 02 September 2010 (02.09.2010) entire document	1-20																		
<p><input type="checkbox"/> Further documents are listed in the continuation of Box C. <input type="checkbox"/></p>																				
<p>* Special categories of cited documents:</p> <table border="0"> <tr> <td style="vertical-align: top;"> <p>"A" document defining the general state of the art which is not considered to be of particular relevance</p> <p>"E" earlier application or patent but published on or after the international filing date</p> <p>"L" document which may throw doubts on priority claim(s) or which is cited to establish the publication date of another citation or other special reason (as specified)</p> <p>"O" document referring to an oral disclosure, use, exhibition or other means</p> <p>"P" document published prior to the international filing date but later than the priority date claimed</p> </td> <td style="vertical-align: top;"> <p>"T" later document published after the international filing date or priority date and not in conflict with the application but cited to understand the principle or theory underlying the invention</p> <p>"X" document of particular relevance; the claimed invention cannot be considered novel or cannot be considered to involve an inventive step when the document is taken alone</p> <p>"Y" document of particular relevance; the claimed invention cannot be considered to involve an inventive step when the document is combined with one or more other such documents, such combination being obvious to a person skilled in the art</p> <p>"&" document member of the same patent family</p> </td> </tr> </table>			<p>"A" document defining the general state of the art which is not considered to be of particular relevance</p> <p>"E" earlier application or patent but published on or after the international filing date</p> <p>"L" document which may throw doubts on priority claim(s) or which is cited to establish the publication date of another citation or other special reason (as specified)</p> <p>"O" document referring to an oral disclosure, use, exhibition or other means</p> <p>"P" document published prior to the international filing date but later than the priority date claimed</p>	<p>"T" later document published after the international filing date or priority date and not in conflict with the application but cited to understand the principle or theory underlying the invention</p> <p>"X" document of particular relevance; the claimed invention cannot be considered novel or cannot be considered to involve an inventive step when the document is taken alone</p> <p>"Y" document of particular relevance; the claimed invention cannot be considered to involve an inventive step when the document is combined with one or more other such documents, such combination being obvious to a person skilled in the art</p> <p>"&" document member of the same patent family</p>																
<p>"A" document defining the general state of the art which is not considered to be of particular relevance</p> <p>"E" earlier application or patent but published on or after the international filing date</p> <p>"L" document which may throw doubts on priority claim(s) or which is cited to establish the publication date of another citation or other special reason (as specified)</p> <p>"O" document referring to an oral disclosure, use, exhibition or other means</p> <p>"P" document published prior to the international filing date but later than the priority date claimed</p>	<p>"T" later document published after the international filing date or priority date and not in conflict with the application but cited to understand the principle or theory underlying the invention</p> <p>"X" document of particular relevance; the claimed invention cannot be considered novel or cannot be considered to involve an inventive step when the document is taken alone</p> <p>"Y" document of particular relevance; the claimed invention cannot be considered to involve an inventive step when the document is combined with one or more other such documents, such combination being obvious to a person skilled in the art</p> <p>"&" document member of the same patent family</p>																			
<p>Date of the actual completion of the international search</p> <p>25 May 2015</p>		<p>Date of mailing of the international search report</p> <p style="text-align: center; font-size: 1.2em;">23 JUN 2015</p>																		
<p>Name and mailing address of the ISA/US</p> <p>Mail Stop PCT, Attn: ISA/US, Commissioner for Patents P.O. Box 1450, Alexandria, Virginia 22313-1450 Facsimile No. 571-273-8300</p>		<p>Authorized officer:</p> <p style="text-align: center;">Blaine R. Copenheaver</p> <p>PCT Helpdesk: 571-272-4300 PCT OSP: 571-272-7774</p>																		