



US00D856193S

(12) **United States Design Patent** (10) **Patent No.:** **US D856,193 S**
Nurnberger et al. (45) **Date of Patent:** **** Aug. 13, 2019**

(54) **AUTOMOBILE AND/OR REPLICAS THEREOF**

(71) Applicant: **ASTON MARTIN LAGONDA LIMITED**, Warwick (GB)

(72) Inventors: **Miles Nurnberger**, Warwick (GB);
Marek Reichman, Warwick (GB);
Antonino Lo Re, Warwick (GB);
Adrian Newey, Milton Keynes (GB)

(73) Assignee: **Aston Martin Lagonda Limited** (GB)

(**) Term: **15 Years**

(21) Appl. No.: **29/626,415**

(22) Filed: **Nov. 16, 2017**

(30) **Foreign Application Priority Data**

May 18, 2017 (EM) 001459150-0001
May 18, 2017 (EM) 001459150-0012

(51) **LOC (12) CL.** **12-08**

(52) **U.S. CL.**
USPC **D12/88**

(58) **Field of Classification Search**
USPC D12/86, 90-92, 88; D21/424, 433, 434;
296/181.1-181.5, 183.1
CPC B62D 25/00; B62D 25/06; B62D 33/00;
B62D 35/00
See application file for complete search history.

(56) **References Cited**

U.S. PATENT DOCUMENTS

D620,396 S 7/2010 Reichman et al.
D626,466 S 11/2010 Reichman et al.
D629,718 S 12/2010 Reichman et al.
D629,719 S 12/2010 Reichman et al.
D629,725 S 12/2010 Reichman et al.
D630,140 S 1/2011 Reichman et al.
D670,640 S 11/2012 Reichman et al.

D687,348 S 8/2013 Nurnberger
D689,812 S 9/2013 Reichman et al.
D692,800 S 11/2013 Wiltshire
D704,102 S 5/2014 Nurnberger
D704,601 S 5/2014 Nurnberger
D726,079 S 4/2015 Reichman et al.
D727,804 S 4/2015 Nurnberger
D730,777 S 6/2015 Nurnberger
D739,789 S 9/2015 Payne
D740,725 S 10/2015 Payne
D758,247 S 6/2016 Nurnberger et al.
D766,474 S 9/2016 Holgate et al.
D772,128 S 11/2016 Platt

(Continued)

OTHER PUBLICATIONS

U.S. Appl. No. 29/542,940, filed Oct. 19, 2015, Kahn.

(Continued)

Primary Examiner — Melody N Brown
(74) *Attorney, Agent, or Firm* — Dorsey & Whitney LLP

(57) **CLAIM**

The ornamental design for an automobile and/or replica thereof, as shown and described.

DESCRIPTION

FIG. 1 is a front elevation view of an automobile and/or replica thereof in accordance with the present design; FIG. 2 is a rear elevation view thereof; FIG. 3 is a top plan view thereof; FIG. 4 is a bottom plan view thereof; FIG. 5 is a right side elevation view thereof, the left side being a mirror image thereof; FIG. 6 is a front perspective view thereof; and, FIG. 7 is a rear perspective view thereof. The broken lines shown throughout the drawing views are for illustrative purposes only and form no part of the claimed design.

1 Claim, 6 Drawing Sheets

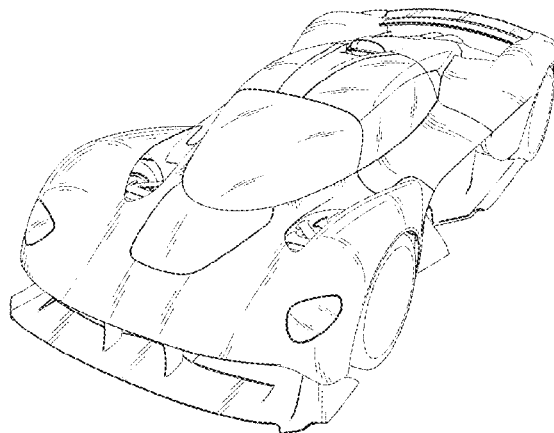

(56)

References Cited

U.S. PATENT DOCUMENTS

D774,950	S	12/2016	Holgate et al.	
D774,995	S	12/2016	Holgate et al.	
D777,070	S	1/2017	Nurnberger	
D778,790	S	2/2017	Nurnberger	
D780,632	S	3/2017	Nurnberger	
D780,633	S	3/2017	Nurnberger et al.	
D780,634	S	3/2017	Nurnberger et al.	
D780,636	S	3/2017	Kahn	
D783,454	S	* 4/2017	Qu	D12/88
D785,503	S	* 5/2017	Qu	D12/88
D785,525	S	5/2017	Nurnberger	
D786,155	S	5/2017	Holgate et al.	
D786,744	S	5/2017	Nurnberger et al.	
D788,642	S	* 6/2017	Manzoni	D12/88
D790,402	S	* 6/2017	Perini	D12/88
D791,018	S	* 7/2017	Mylenek	D12/88
D791,644	S	* 7/2017	Fang	D12/88
D796,404	S	9/2017	Nurnberger	
D800,619	S	10/2017	Platt	
D801,558	S	10/2017	Nurnberger et al.	
D801,857	S	* 11/2017	Kim	D12/88
D817,814	S	* 5/2018	Nurnberger	D12/88
D837,097	S	* 1/2019	Hawkins	D12/88
D839,133	S	* 1/2019	Hilton	D12/88

OTHER PUBLICATIONS

U.S. Appl. No. 29/573,909, filed Aug. 10, 2016, Cooper.
U.S. Appl. No. 29/582,156, filed Oct. 25, 2016, Earley.
U.S. Appl. No. 29/582,165, filed Oct. 25, 2016, Earley.

U.S. Appl. No. 29/582,167, filed Oct. 25, 2016, Earley.
U.S. Appl. No. 29/582,170, filed Oct. 25, 2016, Earley.
U.S. Appl. No. 29/583,268, filed Nov. 3, 2016, Nurnberger et al.
U.S. Appl. No. 29/583,272, filed Nov. 3, 2016, Nurnberger et al.
U.S. Appl. No. 29/583,278, filed Nov. 3, 2016, Nurnberger et al.
U.S. Appl. No. 29/584,625, filed Nov. 16, 2016, Nurnberger et al.
U.S. Appl. No. 29/584,629, filed Nov. 16, 2016, Nurnberger et al.
U.S. Appl. No. 29/589,582, filed Jan. 3, 2017, Nurnberger et al.
U.S. Appl. No. 29/589,583, filed Jan. 3, 2017, Nurnberger et al.
U.S. Appl. No. 29/589,586, filed Jan. 3, 2017, Nurnberger et al.
U.S. Appl. No. 29/589,618, filed Jan. 3, 2017, Nurnberger et al.
U.S. Appl. No. 29/589,621, filed Jan. 3, 2017, Nurnberger et al.
U.S. Appl. No. 29/595,005, filed Feb. 24, 2017, Nurnberger et al.
U.S. Appl. No. 29/604,102, filed May 15, 2017, Nurnberger et al.
U.S. Appl. No. 29/616,003, filed Sep. 1, 2017, Re et al.
U.S. Appl. No. 29/616,006, filed Sep. 1, 2017, Re et al.
U.S. Appl. No. 29/616,008, filed Sep. 1, 2017, Re et al.
U.S. Appl. No. 29/616,010, filed Sep. 1, 2017, Re et al.
U.S. Appl. No. 29/616,014, filed Sep. 1, 2017, Re et al.
U.S. Appl. No. 29/621,813, filed Oct. 11, 2017, Nurnberger et al.
U.S. Appl. No. 29/621,815, filed Oct. 11, 2017, Nurnberger et al.
U.S. Appl. No. 29/626,411, filed Nov. 16, 2017, Nurnberger et al.
U.S. Appl. No. 29/626,419, filed Nov. 16, 2017, Hill et al.
U.S. Appl. No. 29/626,801, filed Nov. 20, 2017, Hill et al.
U.S. Appl. No. 29/631,883, filed Jan. 3, 2018, Hill et al.
U.S. Appl. No. 29/631,887, filed Jan. 3, 2018, Hill et al.
Aston Martin 2013, "Aston Martin Centenary Celebration Programme," 2013; 204 pages.
1976 and 1987 Aston Martin Lagonda, [online], [site visited Jul. 24, 2014], Available from Internet, <URL: <http://www.astomartin.com/heritage/past-models/lagonda>>, 2 pages.

* cited by examiner

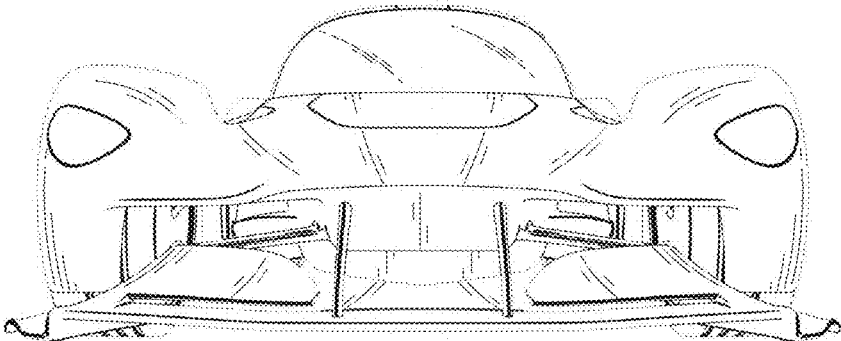

Fig. 1

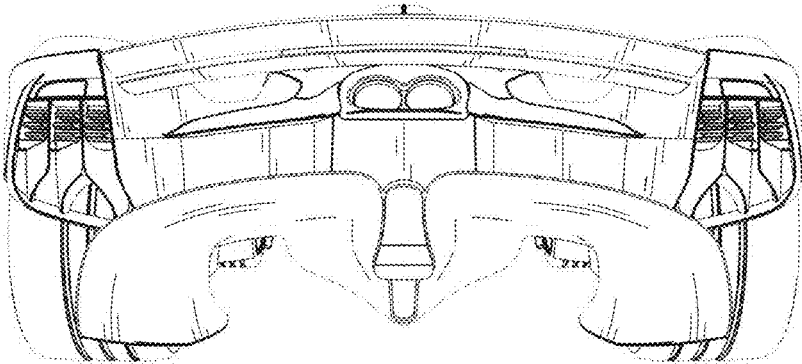

Fig. 2

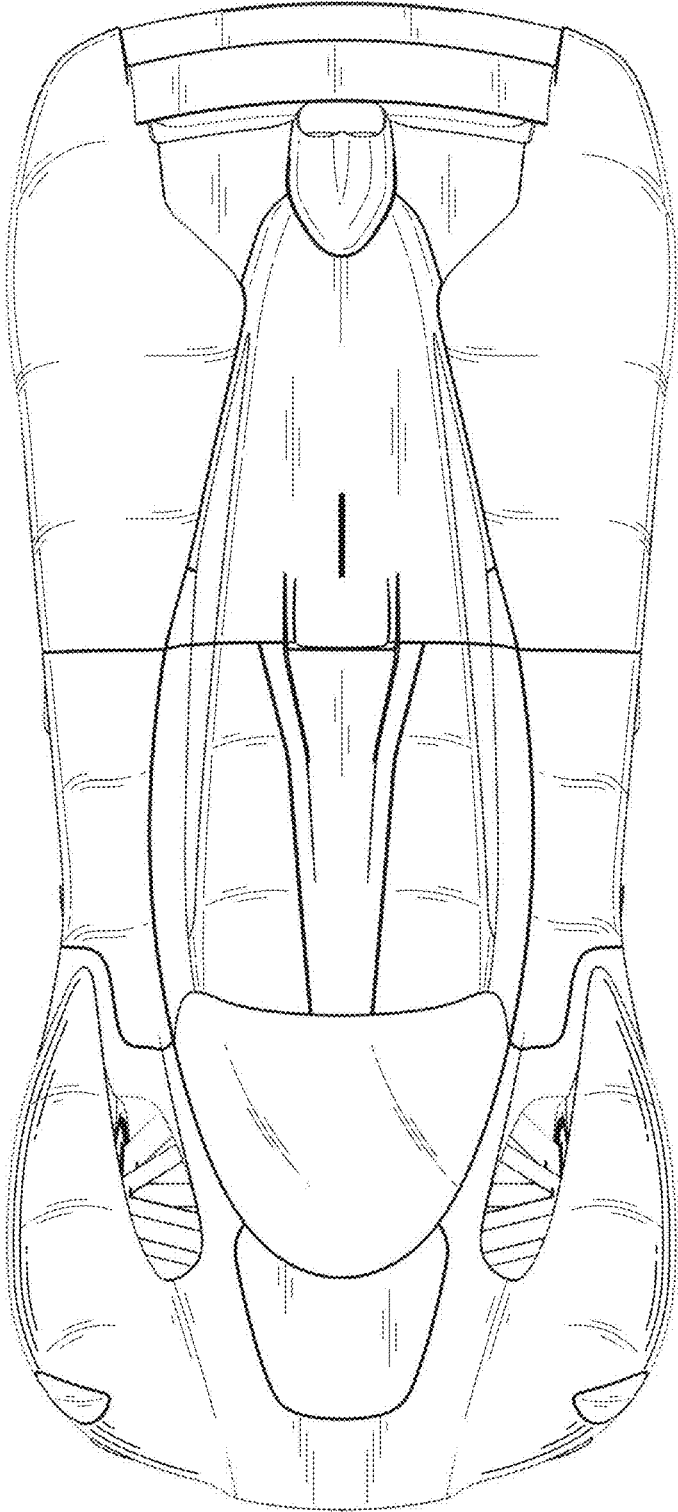

Fig. 3

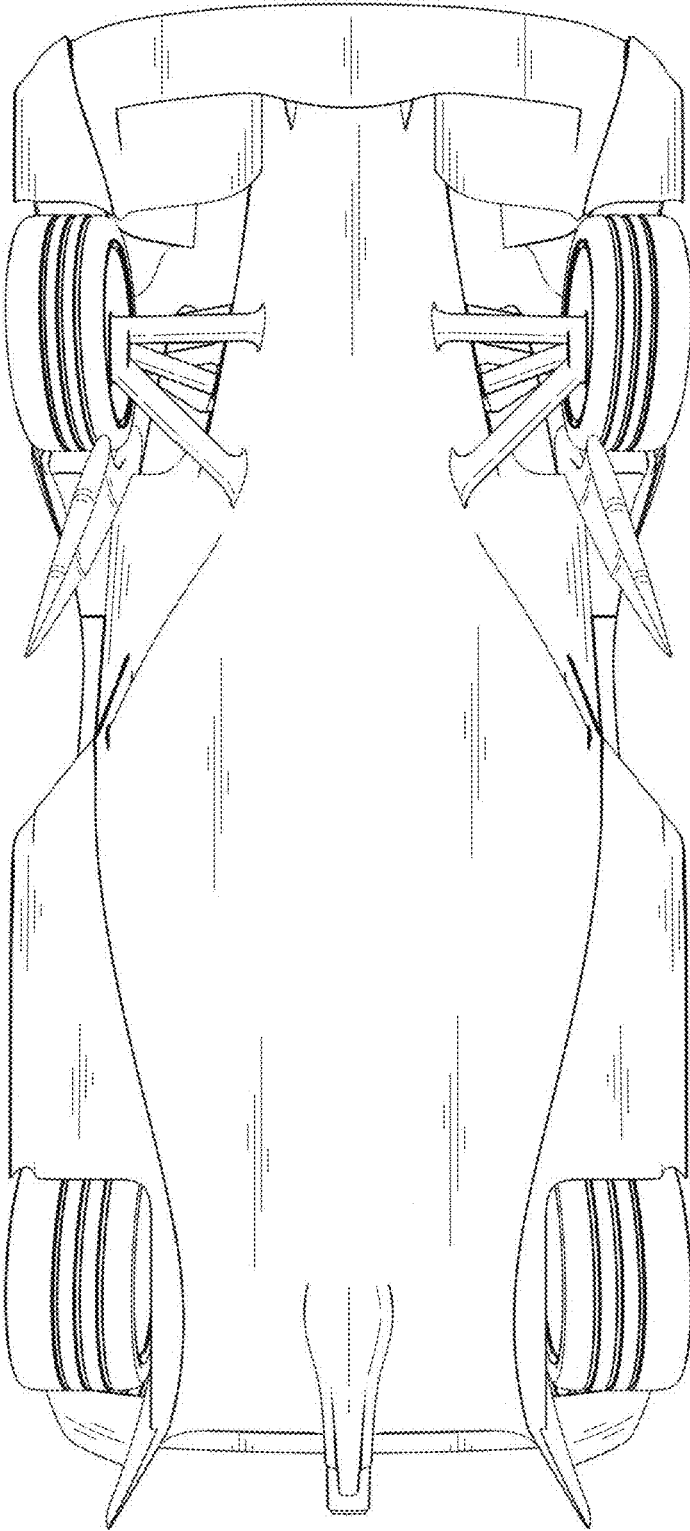

Fig. 4

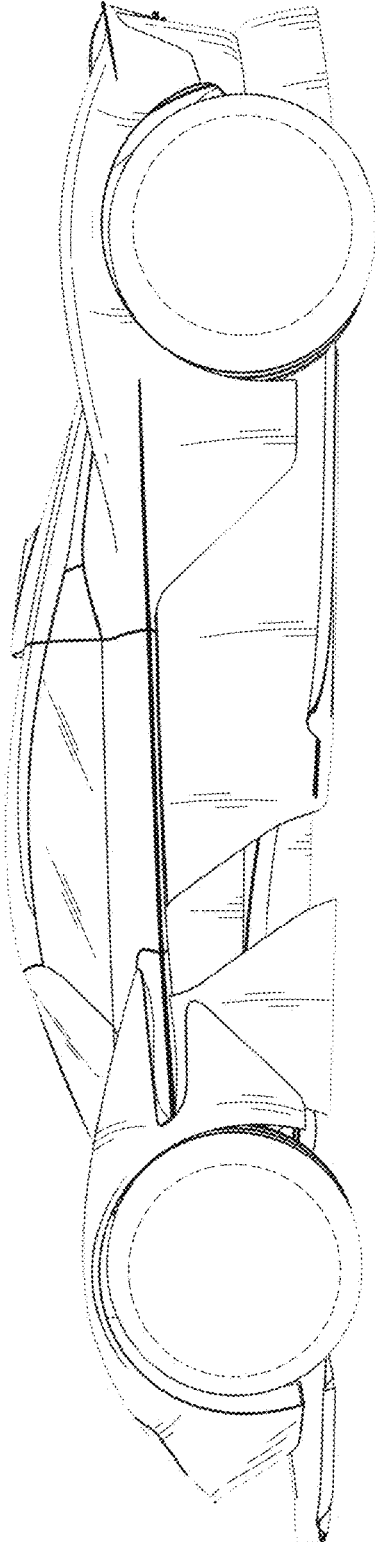

Fig. 5

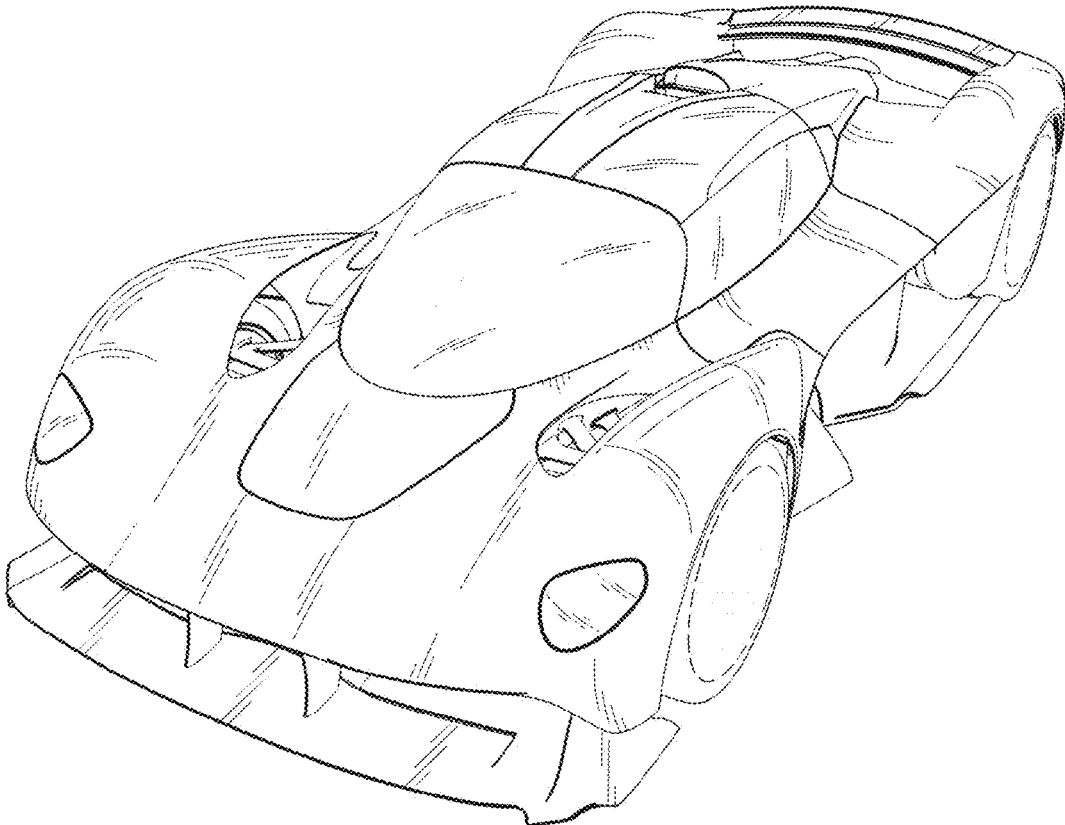

Fig. 6

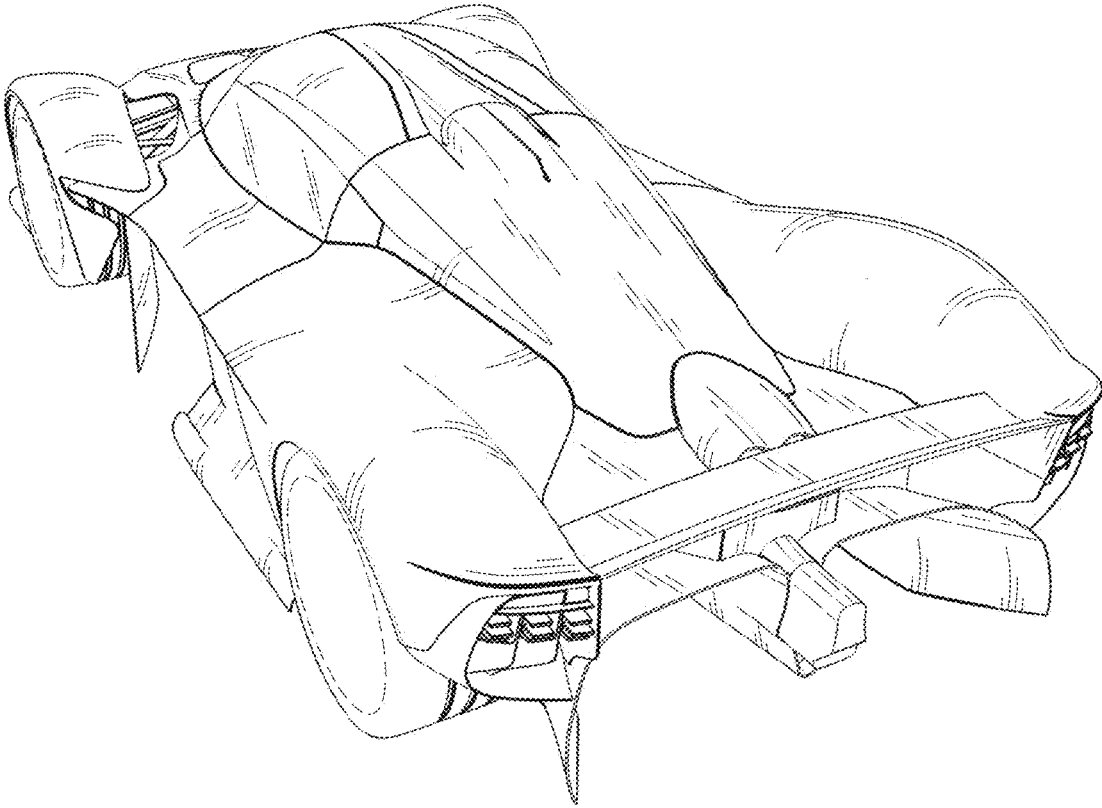

Fig. 7