



(51) International Patent Classification:

A61B 34/30 (2016.01) A61B 90/00 (2016.01)
A61B 34/20 (2016.01) B25J 9/16 (2006.01)
A61B 34/00 (2016.01)

(21) International Application Number:

PCT/IB2021/055496

(22) International Filing Date:

22 June 2021 (22.06.2021)

(25) Filing Language:

English

(26) Publication Language:

English

(30) Priority Data:

63/045,351 29 June 2020 (29.06.2020) US

(71) Applicant: **AURIS HEALTH, INC.** [US/US]; 150 Shoreline Drive, Redwood City, California 94065 (US).

(72) Inventors: **EYRE, Nicholas J.**; 150 Shoreline Drive, Redwood City, California 94065 (US). **SPIES, Alex C.**; 150 Shoreline Drive, Redwood City, California 94065 (US). **WILSON, Colin A.**; 150 Shoreline Drive, Redwood City, California 94065 (US). **MARKEE, Mason Myles**; 150 Shoreline Drive, Redwood City, New Jersey 94065 (US). **MAO, Ying**; 150 Shoreline Drive, Redwood City, California 94065 (US). **YANG, Bo**; 150 Shoreline Drive, Redwood

City, California 94065 (US). **HUANG, Yanan**; 150 Shoreline Drive, Redwood City, California 94065 (US).

(74) Agent: **SHIRTZ, Joseph F.** et al.; Johnson & Johnson, One Johnson & Johnson Plaza, New Brunswick, New Jersey 08933 (US).

(81) Designated States (unless otherwise indicated, for every kind of national protection available): AE, AG, AL, AM, AO, AT, AU, AZ, BA, BB, BG, BH, BN, BR, BW, BY, BZ, CA, CH, CL, CN, CO, CR, CU, CZ, DE, DJ, DK, DM, DO, DZ, EC, EE, EG, ES, FI, GB, GD, GE, GH, GM, GT, HN, HR, HU, ID, IL, IN, IR, IS, IT, JO, JP, KE, KG, KH, KN, KP, KR, KW, KZ, LA, LC, LK, LR, LS, LU, LY, MA, MD, ME, MG, MK, MN, MW, MX, MY, MZ, NA, NG, NI, NO, NZ, OM, PA, PE, PG, PH, PL, PT, QA, RO, RS, RU, RW, SA, SC, SD, SE, SG, SK, SL, ST, SV, SY, TH, TJ, TM, TN, TR, TT, TZ, UA, UG, US, UZ, VC, VN, WS, ZA, ZM, ZW.

(84) Designated States (unless otherwise indicated, for every kind of regional protection available): ARIPO (BW, GH, GM, KE, LR, LS, MW, MZ, NA, RW, SD, SL, ST, SZ, TZ, UG, ZM, ZW), Eurasian (AM, AZ, BY, KG, KZ, RU, TJ, TM), European (AL, AT, BE, BG, CH, CY, CZ, DE, DK, EE, ES, FI, FR, GB, GR, HR, HU, IE, IS, IT, LT, LU, LV, MC, MK, MT, NL, NO, PL, PT, RO, RS, SE, SI, SK, SM,

(54) Title: SYSTEMS AND METHODS FOR DETECTING CONTACT BETWEEN A LINK AND AN EXTERNAL OBJECT

(57) Abstract: Systems and methods for detecting contact between a link and an external object are provided. In one aspect, there is provided a robotic system, including a manipulatable link, a rigid shell configured to overlay the manipulatable link, and one or more sensors positioned between the rigid shell and the manipulatable link. The one or more sensors are configured to detect contact between the rigid shell and an external object.

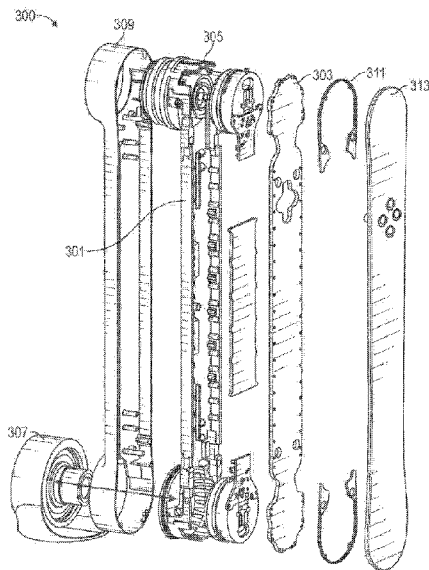

FIG. 22



TR), OAPI (BF, BJ, CF, CG, CI, CM, GA, GN, GQ, GW, KM, ML, MR, NE, SN, TD, TG).

Declarations under Rule 4.17:

- *as to applicant's entitlement to apply for and be granted a patent (Rule 4.17(ii))*
- *as to the applicant's entitlement to claim the priority of the earlier application (Rule 4.17(iii))*

Published:

- *with international search report (Art. 21(3))*
- *in black and white; the international application as filed contained color or greyscale and is available for download from PATENTSCOPE*

SYSTEMS AND METHODS FOR DETECTING CONTACT BETWEEN A LINK AND AN EXTERNAL OBJECT

RELATED APPLICATION

[0001] This application claims the benefit of, and priority to, U.S. Provisional Patent Application Serial No. 63/045,351, titled “Systems and Methods for Detecting Contact between a Link and an External Object”, filed on June 29, 2020, which is incorporated by reference herein in its entirety.

TECHNOLOGICAL FIELD

[0002] The systems and methods disclosed herein are directed to systems and methods for robotic medical systems, and more particularly to detecting contact between a link and an external object.

BACKGROUND

[0003] Robotically-enabled medical system may be capable of performing a variety of medical procedures, including both minimally invasive, such as laparoscopy, and non-invasive, such as endoscopy, procedures. Among endoscopic procedures, the system may be capable of performing bronchoscopy, ureteroscopy, gastroscopy, etc.

[0004] Such robotic medical systems may include robotic arms configured to control the movement of medical tool(s) during a given medical procedure. In order to achieve a desired pose of a medical tool, a robotic arm may be placed into a pose that may cause the robotic arm to come into contact with another object in the environment. Unintended contact or collisions with such external objects can adversely impact the robotic medical system and/or the external object, and thus it is desirable to detect such collisions.

SUMMARY

[0005] The systems, methods and devices of this disclosure each have several innovative aspects, no single one of which is solely responsible for the desirable attributes disclosed herein.

[0006] In one aspect, there is provided a robotic system, comprising: a manipulatable link; a rigid shell configured to overlay the manipulatable link; and one or more sensors positioned between the rigid shell and the manipulatable link, the one or more sensors configured to detect contact between the rigid shell and an external object.

[0007] In certain implementations, the at least one of the one or more sensors can comprise a beam flexure.

[0008] In certain implementations, the beam flexure is configured to engage with an underlying force sensor.

[0009] In certain implementations, the manipulatable link comprises a link of a robotic arm.

[0010] In certain implementations, the manipulatable link comprises a first link or a second link of the robotic arm.

[0011] In certain implementations, at least two or more sensors are located along the proximal link or the distal link of the robotic arm for sensing contact with the respective link.

[0012] In certain implementations, the external object comprises a patient, clinician, or inanimate object.

[0013] In certain implementations, the rigid shell is suspended over the manipulatable link via the one or more sensors.

[0014] In certain implementations, the one or more sensors are further configured to detect a direction of the contact between the rigid shell and the external object.

[0015] In certain implementations, the one or more sensors are further configured to measure a magnitude of a force resulting from the contact between the rigid shell and the external object.

[0016] In certain implementations, the one or more sensors comprise a first set of one or more sensors and a second set of one or more sensors, the first set of one or more sensor positioned between the rigid shell and the manipulatable link at a proximal end of the manipulatable link, and the second set of one or more sensor positioned between the rigid shell and the manipulatable link at a distal end of the manipulatable link.

[0017] In certain implementations, the one or more sensors are further configured to detect a direction of the contact between the rigid shell and the one or more external objects.

[0018] In certain implementations, the one or more sensors are further configured to measure a magnitude of a force resulting from the contact between the rigid shell and the one or more external objects.

[0019] In certain implementations, the one or more sensors are further configured to measure a torque resulting from the contact between the rigid shell and the one or more external objects.

[0020] In certain implementations, the one or more sensors are further configured to measure a direction of relative motion between the rigid shell and the link.

[0021] In another aspect, there is provided a sensor assembly for detecting contact with a manipulatable link of a robotic system, the sensor assembly comprising: a beam flexure; an underlying force sensor for detecting contact with the manipulatable link; and a circuit board.

[0022] In certain implementations, the beam flexure comprises a first end that is fixed and a second end coupled to the force sensor.

[0023] In certain implementations, the beam flexure is engaged with a rigid shell at a point between the first end and the second end.

[0024] In certain implementations, the force exerted on the sensor is proportional to the force applied to the point at which the shell engages the flexure.

[0025] In certain implementations, the beam flexure is engaged with a rigid shell at a fixed point along the beam flexure.

[0026] In certain implementations, a processor is configured to receive an output from the force sensor and generate a force value indicative of a force applied to the rigid shell.

[0027] In yet another aspect, there is provided a robotic system, comprising: a manipulatable link; a rigid shell configured to overlay the manipulatable link; and one or more sensors positioned between the rigid shell and the manipulatable link, the one or more sensors configured to detect contact between one or more external objects and the rigid shell in at least two or more directions.

[0028] In certain implementations, the one or more sensors are further configured to detect contact between the one or more external objects and the rigid shell in one or more rotational directions.

[0029] In certain implementations, at least one of the one or more sensors comprises a beam flexure.

[0030] In certain implementations, the beam flexure engages with an underlying micro-force sensor

[0031] In certain implementations, the manipulatable link comprises a link of a robotic arm.

[0032] In certain implementations, the manipulatable link comprises a proximal link or a distal link of the robotic arm.

[0033] In certain implementations, at least two or more sensors are located along the proximal link or the distal link of the robotic arm for sensing contact with the respective link.

[0034] In certain implementations, the external object comprises a patient, staff or, inanimate object.

[0035] In still yet another aspect, there is provided a method of detecting contact between a robotic manipulator and an external object, the method comprising: receiving a signal from one or more sensors positioned between a link of the robotic manipulator and a rigid shell configured to overlay the link, the received signal indicative of the degree of contact between the rigid shell and the one or more sensors; and determining that contact between the robotic manipulator and the external object has occurred in response to the received signal meeting or exceeding a threshold value.

[0036] In certain implementations, the method further comprises: detecting a direction of the contact between the rigid shell and the external object based on the signal received from the one or more sensors.

[0037] In certain implementations, the method further comprises: measuring a magnitude of a force resulting from the contact between the rigid shell and the external object based on the signal received from the one or more sensors.

[0038] In certain implementations, the method further comprises: measuring a torque resulting from the contact between the rigid shell and the external object based on the signal received from the one or more sensors.

[0039] In certain implementations, the method further comprises: measuring a direction of relative motion between the rigid shell and the link.

[0040] In another aspect, there is provided a robotic arm, comprising: a link; a rigid shell formed over the link; and one or more sensors configured to detect contact between an external object and the rigid shell.

[0041] In certain implementations, the external object comprises one or more of: a patient, a clinician, or an inanimate object.

[0042] In certain implementations, the one or more sensors are positioned in an interstitial space between the link and the rigid shell.

[0043] In certain implementations, the one or more sensors are further configured to measure a magnitude of a force applied to the link.

[0044] In certain implementations, the one or more sensors are further configured to measure a direction of a force applied to the link.

[0045] In certain implementations, the one or more sensors are further configured to measure a torque applied to the link.

[0046] In certain implementations, the one or more sensors comprise a plurality of sensors positioned at different locations of the link.

[0047] In certain implementations, the one or more sensors comprise a plurality of circuit board mounted force sensors.

[0048] In certain implementations, the one or more sensors comprise a plurality of strain gauges.

[0049] In certain implementations, the one or more sensors comprise a plurality of force sensing resistors.

[0050] In certain implementations, the one or more sensors comprise a plurality of capacitive sensors.

[0051] In certain implementations, the one or more sensors comprise a plurality of sensors that support the rigid shell without being fixed to the rigid shell.

[0052] In certain implementations, a given sensor of the one or more sensors comprises a load concentrator configured to control a point at which the rigid shell applies a force to the given sensor.

[0053] In certain implementations, a given sensor of the one or more sensors comprises a flexure configured to scale a force applied to the given sensor and isolate the given sensor from shear forces.

[0054] In certain implementations, the one or more sensors are further configured to measure a relative position of the rigid shell relative to the link.

[0055] In certain implementations, the robotic arm further comprises: a support configured to support the rigid shell relative to the link.

[0056] In certain implementations, the support comprises one or more of: a spring, a flexure, or a suspension.

[0057] In certain implementations, the one or more sensors are further configured to measure a direction of relative motion between the rigid shell and the link.

[0058] In certain implementations, the one or more sensors are further configured to determine a direction of a force applied to the rigid shell.

BRIEF DESCRIPTION OF THE DRAWINGS

[0059] The disclosed aspects will hereinafter be described in conjunction with the appended drawings, provided to illustrate and not to limit the disclosed aspects, wherein like designations denote like elements.

[0060] FIG. 1 illustrates an embodiment of a cart-based robotic system arranged for diagnostic and/or therapeutic bronchoscopy.

[0061] FIG. 2 depicts further aspects of the robotic system of FIG. 1.

[0062] FIG. 3 illustrates an embodiment of the robotic system of FIG. 1 arranged for ureteroscopy.

[0063] FIG. 4 illustrates an embodiment of the robotic system of FIG. 1 arranged for a vascular procedure.

[0064] FIG. 5 illustrates an embodiment of a table-based robotic system arranged for a bronchoscopic procedure.

[0065] FIG. 6 provides an alternative view of the robotic system of FIG. 5.

[0066] FIG. 7 illustrates an example system configured to stow robotic arm(s).

[0067] FIG. 8 illustrates an embodiment of a table-based robotic system configured for a ureteroscopic procedure.

[0068] FIG. 9 illustrates an embodiment of a table-based robotic system configured for a laparoscopic procedure.

[0069] FIG. 10 illustrates an embodiment of the table-based robotic system of FIGS. 5-9 with pitch or tilt adjustment.

[0070] FIG. 11 provides a detailed illustration of the interface between the table and the column of the table-based robotic system of FIGS. 5-10.

[0071] FIG. 12 illustrates an alternative embodiment of a table-based robotic system.

[0072] FIG. 13 illustrates an end view of the table-based robotic system of FIG. 12.

[0073] FIG. 14 illustrates an end view of a table-based robotic system with robotic arms attached thereto.

[0074] FIG. 15 illustrates an exemplary instrument driver.

[0075] FIG. 16 illustrates an exemplary medical instrument with a paired instrument driver.

[0076] FIG. 17 illustrates an alternative design for an instrument driver and instrument where the axes of the drive units are parallel to the axis of the elongated shaft of the instrument.

[0077] FIG. 18 illustrates an instrument having an instrument-based insertion architecture.

[0078] FIG. 19 illustrates an exemplary controller.

[0079] FIG. 20 depicts a block diagram illustrating a localization system that estimates a location of one or more elements of the robotic systems of FIGs. 1-10, such as the location of the instrument of FIGs. 16-18, in accordance to an example embodiment.

[0080] FIGs. 21A and 21B illustrate example robotic links that can form a portion of a robotic arm in accordance with aspects of this disclosure.

[0081] FIG. 22 illustrates an example link including a rigid shell and configured to detect contact with external objects in accordance with aspects of this disclosure.

[0082] FIG. 23 illustrates one example of a force-sensing connection that can be used in the link of FIG. 22 in accordance with aspects of this disclosure.

[0083] FIG. 24A illustrates two views of an embodiment in which fourteen sensors are included in a link in accordance with aspects of this disclosure.

[0084] FIG. 24B illustrates two view of an embodiment in which twelve sensors are included in a link in accordance with aspects of this disclosure.

[0085] FIG. 25 is a flowchart illustrating an example method operable by a surgical robotic system, or component(s) thereof, for detecting contact between a robotic manipulator and an external object in accordance with aspects of this disclosure.

[0086] FIG. 26 illustrates an embodiment of a beam flexure sensor in accordance with aspects of this disclosure.

[0087] FIG. 27 illustrates another embodiment of a beam flexure sensor in accordance with aspects of this disclosure.

[0088] FIG. 28 illustrates an example robotic link that can form a portion of a robotic arm in accordance with aspects of this disclosure.

DETAILED DESCRIPTION

1. Overview.

[0089] Aspects of the present disclosure may be integrated into a robotically-enabled medical system capable of performing a variety of medical procedures, including both minimally invasive, such as laparoscopy, and non-invasive, such as endoscopy, procedures. Among endoscopic procedures, the system may be capable of performing bronchoscopy, ureteroscopy, gastroscopy, etc.

[0090] In addition to performing the breadth of procedures, the system may provide additional benefits, such as enhanced imaging and guidance to assist the physician. Additionally, the system may provide the physician with the ability to perform the procedure from an ergonomic position without the need for awkward arm motions and positions. Still

further, the system may provide the physician with the ability to perform the procedure with improved ease of use such that one or more of the instruments of the system can be controlled by a single user.

[0091] Various embodiments will be described below in conjunction with the drawings for purposes of illustration. It should be appreciated that many other implementations of the disclosed concepts are possible, and various advantages can be achieved with the disclosed implementations. Headings are included herein for reference and to aid in locating various sections. These headings are not intended to limit the scope of the concepts described with respect thereto. Such concepts may have applicability throughout the entire specification.

A. Robotic System — Cart.

[0092] The robotically-enabled medical system may be configured in a variety of ways depending on the particular procedure. FIG. 1 illustrates an embodiment of a cart-based robotically-enabled system 10 arranged for a diagnostic and/or therapeutic bronchoscopy. During a bronchoscopy, the system 10 may comprise a cart 11 having one or more robotic arms 12 to deliver a medical instrument, such as a steerable endoscope 13, which may be a procedure-specific bronchoscope for bronchoscopy, to a natural orifice access point (i.e., the mouth of the patient positioned on a table in the present example) to deliver diagnostic and/or therapeutic tools. As shown, the cart 11 may be positioned proximate to the patient's upper torso in order to provide access to the access point. Similarly, the robotic arms 12 may be actuated to position the bronchoscope relative to the access point. The arrangement in FIG. 1 may also be utilized when performing a gastro-intestinal (GI) procedure with a gastroscope, a specialized endoscope for GI procedures. FIG. 2 depicts an example embodiment of the cart in greater detail.

[0093] With continued reference to FIG. 1, once the cart 11 is properly positioned, the robotic arms 12 may insert the steerable endoscope 13 into the patient robotically, manually, or a combination thereof. As shown, the steerable endoscope 13 may comprise at least two telescoping parts, such as an inner leader portion and an outer sheath portion, each portion coupled to a separate instrument driver from the set of instrument drivers 28, each instrument driver coupled to the distal end of an individual robotic arm. This linear arrangement of the instrument drivers 28, which facilitates coaxially aligning the leader portion with the sheath portion, creates a "virtual rail" 29 that may be repositioned in space by manipulating the one or more robotic arms 12 into different angles and/or positions. The virtual rails described herein are depicted in the Figures using dashed lines, and accordingly the dashed lines do not

depict any physical structure of the system. Translation of the instrument drivers 28 along the virtual rail 29 telescopes the inner leader portion relative to the outer sheath portion or advances or retracts the endoscope 13 from the patient. The angle of the virtual rail 29 may be adjusted, translated, and pivoted based on clinical application or physician preference. For example, in bronchoscopy, the angle and position of the virtual rail 29 as shown represents a compromise between providing physician access to the endoscope 13 while minimizing friction that results from bending the endoscope 13 into the patient's mouth.

[0094] The endoscope 13 may be directed down the patient's trachea and lungs after insertion using precise commands from the robotic system until reaching the target destination or operative site. In order to enhance navigation through the patient's lung network and/or reach the desired target, the endoscope 13 may be manipulated to telescopically extend the inner leader portion from the outer sheath portion to obtain enhanced articulation and greater bend radius. The use of separate instrument drivers 28 also allows the leader portion and sheath portion to be driven independently of each other.

[0095] For example, the endoscope 13 may be directed to deliver a biopsy needle to a target, such as, for example, a lesion or nodule within the lungs of a patient. The needle may be deployed down a working channel that runs the length of the endoscope to obtain a tissue sample to be analyzed by a pathologist. Depending on the pathology results, additional tools may be deployed down the working channel of the endoscope for additional biopsies. After identifying a nodule to be malignant, the endoscope 13 may endoscopically deliver tools to resect the potentially cancerous tissue. In some instances, diagnostic and therapeutic treatments can be delivered in separate procedures. In those circumstances, the endoscope 13 may also be used to deliver a fiducial to "mark" the location of the target nodule as well. In other instances, diagnostic and therapeutic treatments may be delivered during the same procedure.

[0096] The system 10 may also include a movable tower 30, which may be connected via support cables to the cart 11 to provide support for controls, electronics, fluidics, optics, sensors, and/or power to the cart 11. Placing such functionality in the tower 30 allows for a smaller form factor cart 11 that may be more easily adjusted and/or re-positioned by an operating physician and his/her staff. Additionally, the division of functionality between the cart / table and the support tower 30 reduces operating room clutter and facilitates improving clinical workflow. While the cart 11 may be positioned close to the patient, the tower 30 may be stowed in a remote location to stay out of the way during a procedure.

[0097] In support of the robotic systems described above, the tower 30 may include component(s) of a computer-based control system that stores computer program instructions, for example, within a non-transitory computer-readable storage medium such as a persistent magnetic storage drive, solid state drive, etc. The execution of those instructions, whether the execution occurs in the tower 30 or the cart 11, may control the entire system or sub-system(s) thereof. For example, when executed by a processor of the computer system, the instructions may cause the components of the robotics system to actuate the relevant carriages and arm mounts, actuate the robotics arms, and control the medical instruments. For example, in response to receiving the control signal, the motors in the joints of the robotics arms may position the arms into a certain posture.

[0098] The tower 30 may also include a pump, flow meter, valve control, and/or fluid access in order to provide controlled irrigation and aspiration capabilities to the system that may be deployed through the endoscope 13. These components may also be controlled using the computer system of the tower 30. In some embodiments, irrigation and aspiration capabilities may be delivered directly to the endoscope 13 through separate cable(s).

[0099] The tower 30 may include a voltage and surge protector designed to provide filtered and protected electrical power to the cart 11, thereby avoiding placement of a power transformer and other auxiliary power components in the cart 11, resulting in a smaller, more moveable cart 11.

[0100] The tower 30 may also include support equipment for the sensors deployed throughout the robotic system 10. For example, the tower 30 may include optoelectronics equipment for detecting, receiving, and processing data received from the optical sensors or cameras throughout the robotic system 10. In combination with the control system, such optoelectronics equipment may be used to generate real-time images for display in any number of consoles deployed throughout the system, including in the tower 30. Similarly, the tower 30 may also include an electronic subsystem for receiving and processing signals received from deployed electromagnetic (EM) sensors. The tower 30 may also be used to house and position an EM field generator for detection by EM sensors in or on the medical instrument.

[0101] The tower 30 may also include a console 31 in addition to other consoles available in the rest of the system, e.g., console mounted on top of the cart. The console 31 may include a user interface and a display screen, such as a touchscreen, for the physician operator. Consoles in the system 10 are generally designed to provide both robotic controls as well as preoperative and real-time information of the procedure, such as navigational and localization information of the endoscope 13. When the console 31 is not the only console

available to the physician, it may be used by a second operator, such as a nurse, to monitor the health or vitals of the patient and the operation of the system 10, as well as to provide procedure-specific data, such as navigational and localization information. In other embodiments, the console 31 is housed in a body that is separate from the tower 30.

[0102] The tower 30 may be coupled to the cart 11 and endoscope 13 through one or more cables or connections (not shown). In some embodiments, the support functionality from the tower 30 may be provided through a single cable to the cart 11, simplifying and de-cluttering the operating room. In other embodiments, specific functionality may be coupled in separate cabling and connections. For example, while power may be provided through a single power cable to the cart 11, the support for controls, optics, fluidics, and/or navigation may be provided through a separate cable.

[0103] FIG. 2 provides a detailed illustration of an embodiment of the cart 11 from the cart-based robotically-enabled system shown in FIG. 1. The cart 11 generally includes an elongated support structure 14 (often referred to as a “column”), a cart base 15, and a console 16 at the top of the column 14. The column 14 may include one or more carriages, such as a carriage 17 (alternatively “arm support”) for supporting the deployment of one or more robotic arms 12 (three shown in FIG. 2). The carriage 17 may include individually configurable arm mounts that rotate along a perpendicular axis to adjust the base of the robotic arms 12 for better positioning relative to the patient. The carriage 17 also includes a carriage interface 19 that allows the carriage 17 to vertically translate along the column 14.

[0104] The carriage interface 19 is connected to the column 14 through slots, such as slot 20, that are positioned on opposite sides of the column 14 to guide the vertical translation of the carriage 17. The slot 20 contains a vertical translation interface to position and hold the carriage 17 at various vertical heights relative to the cart base 15. Vertical translation of the carriage 17 allows the cart 11 to adjust the reach of the robotic arms 12 to meet a variety of table heights, patient sizes, and physician preferences. Similarly, the individually configurable arm mounts on the carriage 17 allow the robotic arm base 21 of the robotic arms 12 to be angled in a variety of configurations.

[0105] In some embodiments, the slot 20 may be supplemented with slot covers that are flush and parallel to the slot surface to prevent dirt and fluid ingress into the internal chambers of the column 14 and the vertical translation interface as the carriage 17 vertically translates. The slot covers may be deployed through pairs of spring spools positioned near the vertical top and bottom of the slot 20. The covers are coiled within the spools until deployed to extend and retract from their coiled state as the carriage 17 vertically translates up and down.

The spring-loading of the spools provides force to retract the cover into a spool when the carriage 17 translates towards the spool, while also maintaining a tight seal when the carriage 17 translates away from the spool. The covers may be connected to the carriage 17 using, for example, brackets in the carriage interface 19 to facilitate proper extension and retraction of the cover as the carriage 17 translates.

[0106] The column 14 may internally comprise mechanisms, such as gears and motors, that are designed to use a vertically aligned lead screw to translate the carriage 17 in a mechanized fashion in response to control signals generated in response to user inputs, e.g., inputs from the console 16.

[0107] The robotic arms 12 may generally comprise robotic arm bases 21 and end effectors 22, separated by a series of links 23 that are connected by a series of joints 24, each joint comprising an independent actuator, each actuator comprising an independently controllable motor. Each independently controllable joint represents an independent degree of freedom available to the robotic arm 12. Each of the robotic arms 12 may have seven joints, and thus provide seven degrees of freedom. A multitude of joints result in a multitude of degrees of freedom, allowing for “redundant” degrees of freedom. Having redundant degrees of freedom allows the robotic arms 12 to position their respective end effectors 22 at a specific position, orientation, and trajectory in space using different link positions and joint angles. This allows for the system to position and direct a medical instrument from a desired point in space while allowing the physician to move the arm joints into a clinically advantageous position away from the patient to create greater access, while avoiding arm collisions.

[0108] The cart base 15 balances the weight of the column 14, carriage 17, and robotic arms 12 over the floor. Accordingly, the cart base 15 houses heavier components, such as electronics, motors, power supply, as well as components that either enable movement and/or immobilize the cart 11. For example, the cart base 15 includes rollable wheel-shaped casters 25 that allow for the cart 11 to easily move around the room prior to a procedure. After reaching the appropriate position, the casters 25 may be immobilized using wheel locks to hold the cart 11 in place during the procedure.

[0109] Positioned at the vertical end of the column 14, the console 16 allows for both a user interface for receiving user input and a display screen (or a dual-purpose device such as, for example, a touchscreen 26) to provide the physician user with both preoperative and intraoperative data. Potential preoperative data on the touchscreen 26 may include preoperative plans, navigation and mapping data derived from preoperative computerized tomography (CT) scans, and/or notes from preoperative patient interviews. Intraoperative data

on display may include optical information provided from the tool, sensor and coordinate information from sensors, as well as vital patient statistics, such as respiration, heart rate, and/or pulse. The console 16 may be positioned and tilted to allow a physician to access the console 16 from the side of the column 14 opposite the carriage 17. From this position, the physician may view the console 16, robotic arms 12, and patient while operating the console 16 from behind the cart 11. As shown, the console 16 also includes a handle 27 to assist with maneuvering and stabilizing the cart 11.

[0110] FIG. 3 illustrates an embodiment of a robotically-enabled system 10 arranged for ureteroscopy. In a ureteroscopic procedure, the cart 11 may be positioned to deliver a ureteroscope 32, a procedure-specific endoscope designed to traverse a patient's urethra and ureter, to the lower abdominal area of the patient. In a ureteroscopy, it may be desirable for the ureteroscope 32 to be directly aligned with the patient's urethra to reduce friction and forces on the sensitive anatomy in the area. As shown, the cart 11 may be aligned at the foot of the table to allow the robotic arms 12 to position the ureteroscope 32 for direct linear access to the patient's urethra. From the foot of the table, the robotic arms 12 may insert the ureteroscope 32 along the virtual rail 33 directly into the patient's lower abdomen through the urethra.

[0111] After insertion into the urethra, using similar control techniques as in bronchoscopy, the ureteroscope 32 may be navigated into the bladder, ureters, and/or kidneys for diagnostic and/or therapeutic applications. For example, the ureteroscope 32 may be directed into the ureter and kidneys to break up kidney stone build up using a laser or ultrasonic lithotripsy device deployed down the working channel of the ureteroscope 32. After lithotripsy is complete, the resulting stone fragments may be removed using baskets deployed down the ureteroscope 32.

[0112] FIG. 4 illustrates an embodiment of a robotically-enabled system 10 similarly arranged for a vascular procedure. In a vascular procedure, the system 10 may be configured such that the cart 11 may deliver a medical instrument 34, such as a steerable catheter, to an access point in the femoral artery in the patient's leg. The femoral artery presents both a larger diameter for navigation as well as a relatively less circuitous and tortuous path to the patient's heart, which simplifies navigation. As in a ureteroscopic procedure, the cart 11 may be positioned towards the patient's legs and lower abdomen to allow the robotic arms 12 to provide a virtual rail 35 with direct linear access to the femoral artery access point in the patient's thigh / hip region. After insertion into the artery, the medical instrument 34 may be directed and inserted by translating the instrument drivers 28. Alternatively, the cart may be

positioned around the patient's upper abdomen in order to reach alternative vascular access points, such as, for example, the carotid and brachial arteries near the shoulder and wrist.

B. Robotic System – Table.

[0113] Embodiments of the robotically-enabled medical system may also incorporate the patient's table. Incorporation of the table reduces the amount of capital equipment within the operating room by removing the cart, which allows greater access to the patient. FIG. 5 illustrates an embodiment of such a robotically-enabled system arranged for a bronchoscopic procedure. System 36 includes a support structure or column 37 for supporting platform 38 (shown as a "table" or "bed") over the floor. Much like in the cart-based systems, the end effectors of the robotic arms 39 of the system 36 comprise instrument drivers 42 that are designed to manipulate an elongated medical instrument, such as a bronchoscope 40 in FIG. 5, through or along a virtual rail 41 formed from the linear alignment of the instrument drivers 42. In practice, a C-arm for providing fluoroscopic imaging may be positioned over the patient's upper abdominal area by placing the emitter and detector around the table 38.

[0114] FIG. 6 provides an alternative view of the system 36 without the patient and medical instrument for discussion purposes. As shown, the column 37 may include one or more carriages 43 shown as ring-shaped in the system 36, from which the one or more robotic arms 39 may be based. The carriages 43 may translate along a vertical column interface 44 that runs the length of the column 37 to provide different vantage points from which the robotic arms 39 may be positioned to reach the patient. The carriage(s) 43 may rotate around the column 37 using a mechanical motor positioned within the column 37 to allow the robotic arms 39 to have access to multiples sides of the table 38, such as, for example, both sides of the patient. In embodiments with multiple carriages, the carriages may be individually positioned on the column and may translate and/or rotate independently of the other carriages. While the carriages 43 need not surround the column 37 or even be circular, the ring-shape as shown facilitates rotation of the carriages 43 around the column 37 while maintaining structural balance. Rotation and translation of the carriages 43 allows the system 36 to align the medical instruments, such as endoscopes and laparoscopes, into different access points on the patient. In other embodiments (not shown), the system 36 can include a patient table or bed with adjustable arm supports in the form of bars or rails extending alongside it. One or more robotic arms 39 (e.g., via a shoulder with an elbow joint) can be attached to the adjustable arm supports, which can be vertically adjusted. By providing vertical adjustment, the robotic arms 39 are

advantageously capable of being stowed compactly beneath the patient table or bed, and subsequently raised during a procedure.

[0115] The robotic arms 39 may be mounted on the carriages 43 through a set of arm mounts 45 comprising a series of joints that may individually rotate and/or telescopically extend to provide additional configurability to the robotic arms 39. Additionally, the arm mounts 45 may be positioned on the carriages 43 such that, when the carriages 43 are appropriately rotated, the arm mounts 45 may be positioned on either the same side of the table 38 (as shown in FIG. 6), on opposite sides of the table 38 (as shown in FIG. 9), or on adjacent sides of the table 38 (not shown).

[0116] The column 37 structurally provides support for the table 38, and a path for vertical translation of the carriages 43. Internally, the column 37 may be equipped with lead screws for guiding vertical translation of the carriages, and motors to mechanize the translation of the carriages 43 based the lead screws. The column 37 may also convey power and control signals to the carriages 43 and the robotic arms 39 mounted thereon.

[0117] The table base 46 serves a similar function as the cart base 15 in the cart 11 shown in FIG. 2, housing heavier components to balance the table/bed 38, the column 37, the carriages 43, and the robotic arms 39. The table base 46 may also incorporate rigid casters to provide stability during procedures. Deployed from the bottom of the table base 46, the casters may extend in opposite directions on both sides of the base 46 and retract when the system 36 needs to be moved.

[0118] With continued reference to FIG. 6, the system 36 may also include a tower (not shown) that divides the functionality of the system 36 between the table and the tower to reduce the form factor and bulk of the table. As in earlier disclosed embodiments, the tower may provide a variety of support functionalities to the table, such as processing, computing, and control capabilities, power, fluidics, and/or optical and sensor processing. The tower may also be movable to be positioned away from the patient to improve physician access and de-clutter the operating room. Additionally, placing components in the tower allows for more storage space in the table base 46 for potential stowage of the robotic arms 39. The tower may also include a master controller or console that provides both a user interface for user input, such as keyboard and/or pendant, as well as a display screen (or touchscreen) for preoperative and intraoperative information, such as real-time imaging, navigation, and tracking information. In some embodiments, the tower may also contain holders for gas tanks to be used for insufflation.

[0119] In some embodiments, a table base may stow and store the robotic arms when not in use. FIG. 7 illustrates a system 47 that stows robotic arms in an embodiment of the table-based system. In the system 47, carriages 48 may be vertically translated into base 49 to stow robotic arms 50, arm mounts 51, and the carriages 48 within the base 49. Base covers 52 may be translated and retracted open to deploy the carriages 48, arm mounts 51, and robotic arms 50 around column 53, and closed to stow to protect them when not in use. The base covers 52 may be sealed with a membrane 54 along the edges of its opening to prevent dirt and fluid ingress when closed.

[0120] FIG. 8 illustrates an embodiment of a robotically-enabled table-based system configured for a ureteroscopic procedure. In a ureteroscopy, the table 38 may include a swivel portion 55 for positioning a patient off-angle from the column 37 and table base 46. The swivel portion 55 may rotate or pivot around a pivot point (e.g., located below the patient's head) in order to position the bottom portion of the swivel portion 55 away from the column 37. For example, the pivoting of the swivel portion 55 allows a C-arm (not shown) to be positioned over the patient's lower abdomen without competing for space with the column (not shown) below table 38. By rotating the carriage (not shown) around the column 37, the robotic arms 39 may directly insert a ureteroscope 56 along a virtual rail 57 into the patient's groin area to reach the urethra. In a ureteroscopy, stirrups 58 may also be fixed to the swivel portion 55 of the table 38 to support the position of the patient's legs during the procedure and allow clear access to the patient's groin area.

[0121] In a laparoscopic procedure, through small incision(s) in the patient's abdominal wall, minimally invasive instruments may be inserted into the patient's anatomy. In some embodiments, the minimally invasive instruments comprise an elongated rigid member, such as a shaft, which is used to access anatomy within the patient. After inflation of the patient's abdominal cavity, the instruments may be directed to perform surgical or medical tasks, such as grasping, cutting, ablating, suturing, etc. In some embodiments, the instruments can comprise a scope, such as a laparoscope. FIG. 9 illustrates an embodiment of a robotically-enabled table-based system configured for a laparoscopic procedure. As shown in FIG. 9, the carriages 43 of the system 36 may be rotated and vertically adjusted to position pairs of the robotic arms 39 on opposite sides of the table 38, such that instrument 59 may be positioned using the arm mounts 45 to be passed through minimal incisions on both sides of the patient to reach his/her abdominal cavity.

[0122] To accommodate laparoscopic procedures, the robotically-enabled table system may also tilt the platform to a desired angle. FIG. 10 illustrates an embodiment of the

robotically-enabled medical system with pitch or tilt adjustment. As shown in FIG. 10, the system 36 may accommodate tilt of the table 38 to position one portion of the table at a greater distance from the floor than the other. Additionally, the arm mounts 45 may rotate to match the tilt such that the robotic arms 39 maintain the same planar relationship with the table 38. To accommodate steeper angles, the column 37 may also include telescoping portions 60 that allow vertical extension of the column 37 to keep the table 38 from touching the floor or colliding with the table base 46.

[0123] FIG. 11 provides a detailed illustration of the interface between the table 38 and the column 37. Pitch rotation mechanism 61 may be configured to alter the pitch angle of the table 38 relative to the column 37 in multiple degrees of freedom. The pitch rotation mechanism 61 may be enabled by the positioning of orthogonal axes 1, 2 at the column-table interface, each axis actuated by a separate motor 3, 4 responsive to an electrical pitch angle command. Rotation along one screw 5 would enable tilt adjustments in one axis 1, while rotation along the other screw 6 would enable tilt adjustments along the other axis 2. In some embodiments, a ball joint can be used to alter the pitch angle of the table 38 relative to the column 37 in multiple degrees of freedom.

[0124] For example, pitch adjustments are particularly useful when trying to position the table in a Trendelenburg position, i.e., position the patient's lower abdomen at a higher position from the floor than the patient's upper abdomen, for lower abdominal surgery. The Trendelenburg position causes the patient's internal organs to slide towards his/her upper abdomen through the force of gravity, clearing out the abdominal cavity for minimally invasive tools to enter and perform lower abdominal surgical or medical procedures, such as laparoscopic prostatectomy.

[0125] FIGs. 12 and 13 illustrate isometric and end views of an alternative embodiment of a table-based surgical robotics system 100. The surgical robotics system 100 includes one or more adjustable arm supports 105 that can be configured to support one or more robotic arms (see, for example, FIG. 14) relative to a table 101. In the illustrated embodiment, a single adjustable arm support 105 is shown, though an additional arm support 105 can be provided on an opposite side of the table 101. The adjustable arm support 105 can be configured so that it can move relative to the table 101 to adjust and/or vary the position of the adjustable arm support 105 and/or any robotic arms mounted thereto relative to the table 101. For example, the adjustable arm support 105 may be adjusted one or more degrees of freedom relative to the table 101. The adjustable arm support 105 provides high versatility to the system 100, including the ability to easily stow the one or more adjustable arm supports

105 and any robotics arms attached thereto beneath the table 101. The adjustable arm support 105 can be elevated from the stowed position to a position below an upper surface of the table 101. In other embodiments, the adjustable arm support 105 can be elevated from the stowed position to a position above an upper surface of the table 101.

[0126] The adjustable arm support 105 can provide several degrees of freedom, including lift, lateral translation, tilt, etc. In the illustrated embodiment of FIGs. 12 and 13, the arm support 105 is configured with four degrees of freedom, which are illustrated with arrows in FIG. 12. A first degree of freedom allows for adjustment of the adjustable arm support 105 in the z-direction (“Z-lift”). For example, the adjustable arm support 105 can include a carriage 109 configured to move up or down along or relative to a column 102 supporting the table 101. A second degree of freedom can allow the adjustable arm support 105 to tilt. For example, the adjustable arm support 105 can include a rotary joint, which can allow the adjustable arm support 105 to be aligned with the bed in a Trendelenburg position. A third degree of freedom can allow the adjustable arm support 105 to “pivot up,” which can be used to adjust a distance between a side of the table 101 and the adjustable arm support 105. A fourth degree of freedom can permit translation of the adjustable arm support 105 along a longitudinal length of the table.

[0127] The surgical robotics system 100 in FIGs. 12 and 13 can comprise a table supported by a column 102 that is mounted to a base 103. The base 103 and the column 102 support the table 101 relative to a support surface. A floor axis 131 and a support axis 133 are shown in FIG. 13.

[0128] The adjustable arm support 105 can be mounted to the column 102. In other embodiments, the arm support 105 can be mounted to the table 101 or base 103. The adjustable arm support 105 can include a carriage 109, a bar or rail connector 111 and a bar or rail 107. In some embodiments, one or more robotic arms mounted to the rail 107 can translate and move relative to one another.

[0129] The carriage 109 can be attached to the column 102 by a first joint 113, which allows the carriage 109 to move relative to the column 102 (e.g., such as up and down a first or vertical axis 123). The first joint 113 can provide the first degree of freedom (Z-lift) to the adjustable arm support 105. The adjustable arm support 105 can include a second joint 115, which provides the second degree of freedom (tilt) for the adjustable arm support 105. The adjustable arm support 105 can include a third joint 117, which can provide the third degree of freedom (“pivot up”) for the adjustable arm support 105. An additional joint 119 (shown in FIG. 13) can be provided that mechanically constrains the third joint 117 to maintain an orientation of the rail 107 as the rail connector 111 is rotated about a third axis 127. The

adjustable arm support 105 can include a fourth joint 121, which can provide a fourth degree of freedom (translation) for the adjustable arm support 105 along a fourth axis 129.

[0130] FIG. 14 illustrates an end view of the surgical robotics system 140A with two adjustable arm supports 105A, 105B mounted on opposite sides of a table 101. A first robotic arm 142A is attached to the bar or rail 107A of the first adjustable arm support 105B. The first robotic arm 142A includes a base 144A attached to the rail 107A. The distal end of the first robotic arm 142A includes an instrument drive mechanism 146A that can attach to one or more robotic medical instruments or tools. Similarly, the second robotic arm 142B includes a base 144B attached to the rail 107B. The distal end of the second robotic arm 142B includes an instrument drive mechanism 146B. The instrument drive mechanism 146B can be configured to attach to one or more robotic medical instruments or tools.

[0131] In some embodiments, one or more of the robotic arms 142A, 142B comprises an arm with seven or more degrees of freedom. In some embodiments, one or more of the robotic arms 142A, 142B can include eight degrees of freedom, including an insertion axis (1-degree of freedom including insertion), a wrist (3-degrees of freedom including wrist pitch, yaw and roll), an elbow (1-degree of freedom including elbow pitch), a shoulder (2-degrees of freedom including shoulder pitch and yaw), and base 144A, 144B (1-degree of freedom including translation). In some embodiments, the insertion degree of freedom can be provided by the robotic arm 142A, 142B, while in other embodiments, the instrument itself provides insertion via an instrument-based insertion architecture.

C. Instrument Driver & Interface.

[0132] The end effectors of the system's robotic arms may comprise (i) an instrument driver (alternatively referred to as "instrument drive mechanism" or "instrument device manipulator") that incorporates electro-mechanical means for actuating the medical instrument and (ii) a removable or detachable medical instrument, which may be devoid of any electro-mechanical components, such as motors. This dichotomy may be driven by the need to sterilize medical instruments used in medical procedures, and the inability to adequately sterilize expensive capital equipment due to their intricate mechanical assemblies and sensitive electronics. Accordingly, the medical instruments may be designed to be detached, removed, and interchanged from the instrument driver (and thus the system) for individual sterilization or disposal by the physician or the physician's staff. In contrast, the instrument drivers need not be changed or sterilized, and may be draped for protection.

[0133] FIG. 15 illustrates an example instrument driver. Positioned at the distal end of a robotic arm, instrument driver 62 comprises one or more drive units 63 arranged with parallel axes to provide controlled torque to a medical instrument via drive shafts 64. Each drive unit 63 comprises an individual drive shaft 64 for interacting with the instrument, a gear head 65 for converting the motor shaft rotation to a desired torque, a motor 66 for generating the drive torque, an encoder 67 to measure the speed of the motor shaft and provide feedback to control circuitry, and control circuitry 68 for receiving control signals and actuating the drive unit. Each drive unit 63 being independently controlled and motorized, the instrument driver 62 may provide multiple (e.g., four as shown in FIG. 15) independent drive outputs to the medical instrument. In operation, the control circuitry 68 would receive a control signal, transmit a motor signal to the motor 66, compare the resulting motor speed as measured by the encoder 67 with the desired speed, and modulate the motor signal to generate the desired torque.

[0134] For procedures that require a sterile environment, the robotic system may incorporate a drive interface, such as a sterile adapter connected to a sterile drape, that sits between the instrument driver and the medical instrument. The chief purpose of the sterile adapter is to transfer angular motion from the drive shafts of the instrument driver to the drive inputs of the instrument while maintaining physical separation, and thus sterility, between the drive shafts and drive inputs. Accordingly, an example sterile adapter may comprise a series of rotational inputs and outputs intended to be mated with the drive shafts of the instrument driver and drive inputs on the instrument. Connected to the sterile adapter, the sterile drape, comprised of a thin, flexible material such as transparent or translucent plastic, is designed to cover the capital equipment, such as the instrument driver, robotic arm, and cart (in a cart-based system) or table (in a table-based system). Use of the drape would allow the capital equipment to be positioned proximate to the patient while still being located in an area not requiring sterilization (i.e., non-sterile field). On the other side of the sterile drape, the medical instrument may interface with the patient in an area requiring sterilization (i.e., sterile field).

D. Medical Instrument.

[0135] FIG. 16 illustrates an example medical instrument with a paired instrument driver. Like other instruments designed for use with a robotic system, medical instrument 70 comprises an elongated shaft 71 (or elongate body) and an instrument base 72. The instrument base 72, also referred to as an “instrument handle” due to its intended design for manual interaction by the physician, may generally comprise rotatable drive inputs 73, e.g., receptacles,

pulleys or spools, that are designed to be mated with drive outputs 74 that extend through a drive interface on instrument driver 75 at the distal end of robotic arm 76. When physically connected, latched, and/or coupled, the mated drive inputs 73 of the instrument base 72 may share axes of rotation with the drive outputs 74 in the instrument driver 75 to allow the transfer of torque from the drive outputs 74 to the drive inputs 73. In some embodiments, the drive outputs 74 may comprise splines that are designed to mate with receptacles on the drive inputs 73.

[0136] The elongated shaft 71 is designed to be delivered through either an anatomical opening or lumen, e.g., as in endoscopy, or a minimally invasive incision, e.g., as in laparoscopy. The elongated shaft 71 may be either flexible (e.g., having properties similar to an endoscope) or rigid (e.g., having properties similar to a laparoscope) or contain a customized combination of both flexible and rigid portions. When designed for laparoscopy, the distal end of a rigid elongated shaft may be connected to an end effector extending from a jointed wrist formed from a clevis with at least one degree of freedom and a surgical tool or medical instrument, such as, for example, a grasper or scissors, that may be actuated based on force from the tendons as the drive inputs rotate in response to torque received from the drive outputs 74 of the instrument driver 75. When designed for endoscopy, the distal end of a flexible elongated shaft may include a steerable or controllable bending section that may be articulated and bent based on torque received from the drive outputs 74 of the instrument driver 75.

[0137] Torque from the instrument driver 75 is transmitted down the elongated shaft 71 using tendons along the elongated shaft 71. These individual tendons, such as pull wires, may be individually anchored to individual drive inputs 73 within the instrument handle 72. From the instrument handle 72, the tendons are directed down one or more pull lumens along the elongated shaft 71 and anchored at the distal portion of the elongated shaft 71, or in the wrist at the distal portion of the elongated shaft. During a surgical procedure, such as a laparoscopic, endoscopic or hybrid procedure, these tendons may be coupled to a distally mounted end effector, such as a wrist, grasper, or scissor. Under such an arrangement, torque exerted on drive inputs 73 would transfer tension to the tendon, thereby causing the end effector to actuate in some way. In some embodiments, during a surgical procedure, the tendon may cause a joint to rotate about an axis, thereby causing the end effector to move in one direction or another. Alternatively, the tendon may be connected to one or more jaws of a grasper at the distal end of the elongated shaft 71, where tension from the tendon causes the grasper to close.

[0138] In endoscopy, the tendons may be coupled to a bending or articulating section positioned along the elongated shaft 71 (e.g., at the distal end) via adhesive, control ring, or other mechanical fixation. When fixedly attached to the distal end of a bending section, torque exerted on the drive inputs 73 would be transmitted down the tendons, causing the softer, bending section (sometimes referred to as the articulable section or region) to bend or articulate. Along the non-bending sections, it may be advantageous to spiral or helix the individual pull lumens that direct the individual tendons along (or inside) the walls of the endoscope shaft to balance the radial forces that result from tension in the pull wires. The angle of the spiraling and/or spacing therebetween may be altered or engineered for specific purposes, wherein tighter spiraling exhibits lesser shaft compression under load forces, while lower amounts of spiraling results in greater shaft compression under load forces, but limits bending. On the other end of the spectrum, the pull lumens may be directed parallel to the longitudinal axis of the elongated shaft 71 to allow for controlled articulation in the desired bending or articulable sections.

[0139] In endoscopy, the elongated shaft 71 houses a number of components to assist with the robotic procedure. The shaft 71 may comprise a working channel for deploying surgical tools (or medical instruments), irrigation, and/or aspiration to the operative region at the distal end of the shaft 71. The shaft 71 may also accommodate wires and/or optical fibers to transfer signals to/from an optical assembly at the distal tip, which may include an optical camera. The shaft 71 may also accommodate optical fibers to carry light from proximally-located light sources, such as light emitting diodes, to the distal end of the shaft 71.

[0140] At the distal end of the instrument 70, the distal tip may also comprise the opening of a working channel for delivering tools for diagnostic and/or therapy, irrigation, and aspiration to an operative site. The distal tip may also include a port for a camera, such as a fiberscope or a digital camera, to capture images of an internal anatomical space. Relatedly, the distal tip may also include ports for light sources for illuminating the anatomical space when using the camera.

[0141] In the example of FIG. 16, the drive shaft axes, and thus the drive input axes, are orthogonal to the axis of the elongated shaft 71. This arrangement, however, complicates roll capabilities for the elongated shaft 71. Rolling the elongated shaft 71 along its axis while keeping the drive inputs 73 static results in undesirable tangling of the tendons as they extend off the drive inputs 73 and enter pull lumens within the elongated shaft 71. The resulting entanglement of such tendons may disrupt any control algorithms intended to predict movement of the flexible elongated shaft 71 during an endoscopic procedure.

[0142] FIG. 17 illustrates an alternative design for an instrument driver and instrument where the axes of the drive units are parallel to the axis of the elongated shaft of the instrument. As shown, a circular instrument driver 80 comprises four drive units with their drive outputs 81 aligned in parallel at the end of a robotic arm 82. The drive units, and their respective drive outputs 81, are housed in a rotational assembly 83 of the instrument driver 80 that is driven by one of the drive units within the assembly 83. In response to torque provided by the rotational drive unit, the rotational assembly 83 rotates along a circular bearing that connects the rotational assembly 83 to the non-rotational portion 84 of the instrument driver 80. Power and controls signals may be communicated from the non-rotational portion 84 of the instrument driver 80 to the rotational assembly 83 through electrical contacts that may be maintained through rotation by a brushed slip ring connection (not shown). In other embodiments, the rotational assembly 83 may be responsive to a separate drive unit that is integrated into the non-rotatable portion 84, and thus not in parallel to the other drive units. The rotational mechanism 83 allows the instrument driver 80 to rotate the drive units, and their respective drive outputs 81, as a single unit around an instrument driver axis 85.

[0143] Like earlier disclosed embodiments, an instrument 86 may comprise an elongated shaft portion 88 and an instrument base 87 (shown with a transparent external skin for discussion purposes) comprising a plurality of drive inputs 89 (such as receptacles, pulleys, and spools) that are configured to receive the drive outputs 81 in the instrument driver 80. Unlike prior disclosed embodiments, the instrument shaft 88 extends from the center of the instrument base 87 with an axis substantially parallel to the axes of the drive inputs 89, rather than orthogonal as in the design of FIG. 16.

[0144] When coupled to the rotational assembly 83 of the instrument driver 80, the medical instrument 86, comprising instrument base 87 and instrument shaft 88, rotates in combination with the rotational assembly 83 about the instrument driver axis 85. Since the instrument shaft 88 is positioned at the center of instrument base 87, the instrument shaft 88 is coaxial with instrument driver axis 85 when attached. Thus, rotation of the rotational assembly 83 causes the instrument shaft 88 to rotate about its own longitudinal axis. Moreover, as the instrument base 87 rotates with the instrument shaft 88, any tendons connected to the drive inputs 89 in the instrument base 87 are not tangled during rotation. Accordingly, the parallelism of the axes of the drive outputs 81, drive inputs 89, and instrument shaft 88 allows for the shaft rotation without tangling any control tendons.

[0145] FIG. 18 illustrates an instrument having an instrument based insertion architecture in accordance with some embodiments. The instrument 150 can be coupled to any

of the instrument drivers discussed above. The instrument 150 comprises an elongated shaft 152, an end effector 162 connected to the shaft 152, and a handle 170 coupled to the shaft 152. The elongated shaft 152 comprises a tubular member having a proximal portion 154 and a distal portion 156. The elongated shaft 152 comprises one or more channels or grooves 158 along its outer surface. The grooves 158 are configured to receive one or more wires or cables 180 therethrough. One or more cables 180 thus run along an outer surface of the elongated shaft 152. In other embodiments, cables 180 can also run through the elongated shaft 152. Manipulation of the one or more cables 180 (e.g., via an instrument driver) results in actuation of the end effector 162.

[0146] The instrument handle 170, which may also be referred to as an instrument base, may generally comprise an attachment interface 172 having one or more mechanical inputs 174, e.g., receptacles, pulleys or spools, that are designed to be reciprocally mated with one or more torque couplers on an attachment surface of an instrument driver.

[0147] In some embodiments, the instrument 150 comprises a series of pulleys or cables that enable the elongated shaft 152 to translate relative to the handle 170. In other words, the instrument 150 itself comprises an instrument-based insertion architecture that accommodates insertion of the instrument, thereby minimizing the reliance on a robot arm to provide insertion of the instrument 150. In other embodiments, a robotic arm can be largely responsible for instrument insertion.

E. Controller.

[0148] Any of the robotic systems described herein can include an input device or controller for manipulating an instrument attached to a robotic arm. In some embodiments, the controller can be coupled (e.g., communicatively, electronically, electrically, wirelessly and/or mechanically) with an instrument such that manipulation of the controller causes a corresponding manipulation of the instrument e.g., via master slave control.

[0149] FIG. 19 is a perspective view of an embodiment of a controller 182. In the present embodiment, the controller 182 comprises a hybrid controller that can have both impedance and admittance control. In other embodiments, the controller 182 can utilize just impedance or passive control. In other embodiments, the controller 182 can utilize just admittance control. By being a hybrid controller, the controller 182 advantageously can have a lower perceived inertia while in use.

[0150] In the illustrated embodiment, the controller 182 is configured to allow manipulation of two medical instruments, and includes two handles 184. Each of the handles 184 is connected to a gimbal 186. Each gimbal 186 is connected to a positioning platform 188.

[0151] As shown in FIG. 19, each positioning platform 188 includes a selective compliance assembly robot arm (SCARA) 198 coupled to a column 194 by a prismatic joint 196. The prismatic joints 196 are configured to translate along the column 194 (e.g., along rails 197) to allow each of the handles 184 to be translated in the z-direction, providing a first degree of freedom. The SCARA 198 is configured to allow motion of the handle 184 in an x-y plane, providing two additional degrees of freedom.

[0152] In some embodiments, one or more load cells are positioned in the controller. For example, in some embodiments, a load cell (not shown) is positioned in the body of each of the gimbals 186. By providing a load cell, portions of the controller 182 are capable of operating under admittance control, thereby advantageously reducing the perceived inertia of the controller while in use. In some embodiments, the positioning platform 188 is configured for admittance control, while the gimbal 186 is configured for impedance control. In other embodiments, the gimbal 186 is configured for admittance control, while the positioning platform 188 is configured for impedance control. Accordingly, for some embodiments, the translational or positional degrees of freedom of the positioning platform 188 can rely on admittance control, while the rotational degrees of freedom of the gimbal 186 rely on impedance control.

F. Navigation and Control.

[0153] Traditional endoscopy may involve the use of fluoroscopy (e.g., as may be delivered through a C-arm) and other forms of radiation-based imaging modalities to provide endoluminal guidance to an operator physician. In contrast, the robotic systems contemplated by this disclosure can provide for non-radiation-based navigational and localization means to reduce physician exposure to radiation and reduce the amount of equipment within the operating room. As used herein, the term “localization” may refer to determining and/or monitoring the position of objects in a reference coordinate system. Technologies such as preoperative mapping, computer vision, real-time EM tracking, and robot command data may be used individually or in combination to achieve a radiation-free operating environment. In other cases, where radiation-based imaging modalities are still used, the preoperative mapping, computer vision, real-time EM tracking, and robot command data may be used individually or

in combination to improve upon the information obtained solely through radiation-based imaging modalities.

[0154] FIG. 20 is a block diagram illustrating a localization system 90 that estimates a location of one or more elements of the robotic system, such as the location of the instrument, in accordance to an example embodiment. The localization system 90 may be a set of one or more computer devices configured to execute one or more instructions. The computer devices may be embodied by a processor (or processors) and computer-readable memory in one or more components discussed above. By way of example and not limitation, the computer devices may be in the tower 30 shown in FIG. 1, the cart 11 shown in FIGs. 1-4, the beds shown in FIGs. 5-14, etc.

[0155] As shown in FIG. 20, the localization system 90 may include a localization module 95 that processes input data 91-94 to generate location data 96 for the distal tip of a medical instrument. The location data 96 may be data or logic that represents a location and/or orientation of the distal end of the instrument relative to a frame of reference. The frame of reference can be a frame of reference relative to the anatomy of the patient or to a known object, such as an EM field generator (see discussion below for the EM field generator).

[0156] The various input data 91-94 are now described in greater detail. Preoperative mapping may be used by the localization module 95 to generate model data 91. Preoperative mapping may be accomplished through the use of the collection of low dose CT scans. Preoperative CT scans are reconstructed into three-dimensional images, which are visualized, e.g. as “slices” of a cutaway view of the patient’s internal anatomy. When analyzed in the aggregate, image-based models for anatomical cavities, spaces and structures of the patient’s anatomy, such as a patient lung network, may be generated. Techniques such as center-line geometry may be determined and approximated from the CT images to develop a three-dimensional volume of the patient’s anatomy, referred to as model data 91 (also referred to as “preoperative model data” when generated using only preoperative CT scans). The use of center-line geometry is discussed in U.S. Pat. App. No. 14/523,760, the contents of which are herein incorporated in its entirety. Network topological models may also be derived from the CT-images, and are particularly appropriate for bronchoscopy.

[0157] In some embodiments, the instrument may be equipped with a camera to provide vision data (or image data) 92 to the localization module 95. The localization module 95 may process the vision data 92 to enable one or more vision-based (or image-based) location tracking modules or features. For example, the preoperative model data 91 may be used in conjunction with the vision data 92 to enable computer vision-based tracking of the medical

instrument (e.g., an endoscope or an instrument advance through a working channel of the endoscope). For example, using the preoperative model data 91, the robotic system may generate a library of expected endoscopic images from the model based on the expected path of travel of the endoscope, each image linked to a location within the model. Intraoperatively, this library may be referenced by the robotic system in order to compare real-time images captured at the camera (e.g., a camera at a distal end of the endoscope) to those in the image library to assist localization.

[0158] Other computer vision-based tracking techniques use feature tracking to determine motion of the camera, and thus the endoscope. Some features of the localization module 95 may identify circular geometries in the preoperative model data 91 that correspond to anatomical lumens and track the change of those geometries to determine which anatomical lumen was selected, as well as the relative rotational and/or translational motion of the camera. Use of a topological map may further enhance vision-based algorithms or techniques.

[0159] Optical flow, another computer vision-based technique, may analyze the displacement and translation of image pixels in a video sequence in the vision data 92 to infer camera movement. Examples of optical flow techniques may include motion detection, object segmentation calculations, luminance, motion compensated encoding, stereo disparity measurement, etc. Through the comparison of multiple frames over multiple iterations, movement and location of the camera (and thus the endoscope) may be determined.

[0160] The localization module 95 may use real-time EM tracking and EM data 93 to generate a real-time location of the endoscope in a global coordinate system that may be registered to the patient's anatomy, represented by the preoperative model. In EM tracking, an EM sensor (or tracker) comprising one or more sensor coils embedded in one or more locations and orientations in a medical instrument (e.g., an endoscopic tool) measures the variation in the EM field created by one or more static EM field generators positioned at a known location. The location information detected by the EM sensors is stored as EM data 93. The EM field generator (or transmitter), may be placed close to the patient to create a low intensity magnetic field that the embedded sensor may detect. The magnetic field induces small currents in the sensor coils of the EM sensor, which may be analyzed to determine the distance and angle between the EM sensor and the EM field generator. These distances and orientations may be intraoperatively "registered" to the patient anatomy (e.g., the preoperative model) in order to determine the geometric transformation that aligns a single location in the coordinate system with a position in the preoperative model of the patient's anatomy. Once registered, an embedded EM tracker in one or more positions of the medical instrument (e.g., the distal tip of

an endoscope) may provide real-time indications of the progression of the medical instrument through the patient's anatomy.

[0161] Robotic command and kinematics data 94 may also be used by the localization module 95 to provide location data 96 for the robotic system. Device pitch and yaw resulting from articulation commands may be determined during preoperative calibration. Intraoperatively, these calibration measurements may be used in combination with known insertion depth information to estimate the position of the instrument. Alternatively, these calculations may be analyzed in combination with EM, vision, and/or topological modeling to estimate the position of the medical instrument within the network.

[0162] As FIG. 20 shows, a number of other input data can be used by the localization module 95. For example, although not shown in FIG. 20, an instrument utilizing shape-sensing fiber can provide shape data that the localization module 95 can use to determine the location and shape of the instrument.

[0163] The localization module 95 may use the input data 91-94 in combination(s). In some cases, such a combination may use a probabilistic approach where the localization module 95 assigns a confidence weight to the location determined from each of the input data 91-94. Thus, where the EM data may not be reliable (as may be the case where there is EM interference) the confidence of the location determined by the EM data 93 can be decrease and the localization module 95 may rely more heavily on the vision data 92 and/or the robotic command and kinematics data 94.

[0164] As discussed above, the robotic systems discussed herein may be designed to incorporate a combination of one or more of the technologies above. The robotic system's computer-based control system, based in the tower, bed and/or cart, may store computer program instructions, for example, within a non-transitory computer-readable storage medium such as a persistent magnetic storage drive, solid state drive, or the like, that, upon execution, cause the system to receive and analyze sensor data and user commands, generate control signals throughout the system, and display the navigational and localization data, such as the position of the instrument within the global coordinate system, anatomical map, etc.

2. Introduction to Detection of Contact Between a Link and an External Object.

[0165] Embodiments of the disclosure relate to systems and techniques for detecting contact between a robotic arm/manipulator and an external object. As described herein, robotic medical systems may include a plurality of robotic arms configured to control the movement of medical tool(s) during a given medical procedure. In order to achieve a

desired pose of a medical tool, a robotic arm may be placed into a pose, which may cause the robotic arm to come into contact with an external object, such as, for example, a patient, bedside staff, or inanimate object(s) (e.g., accessories on the bed). If undetected, such contact (also referred to as a “collision”) can result in injury to the patient or beside staff and/or damage to the robotic arm or external object(s). By detecting contact between the robotic arm and the external object early enough (e.g., before the contact results in a force greater than a threshold value), injury and/or damage can be reduced or prevented.

[0166] One safety consideration relates to when a robotic link (e.g., a portion of robotic arm) comes into contact with an external object. For example, when the robotic arm comes into contact with a patient in an unplanned or accidental manner, harmful forces may be created and/or transferred to the patient. Thus, one challenge with robotic medical systems is detecting contact with surrounding objects and people (including the patient) to ensure that the robotic system can safely operate around people.

[0167] Aspects of this disclosure provide systems and techniques for detecting contact between or with links (e.g., of the robotic arms), which can involve the use of one or more sensors. Once contact is detected, the robotic system can take action to reduce further contact. For example, in some implementations the robotic arm can stop further movement upon detection of contact with an external object.

Contact Detection Using a Force Sensing Floating Shell

[0168] According to aspects of this disclosure, a robotic arm can comprise a plurality of robotic links connected via a series of joints providing a plurality of degrees-of-freedom of movement that enable the robotic arm to be positioned in a variety of different poses or states. FIGs. 21A and 21B illustrate example robotic links that can form a portion of a robotic arm in accordance with aspects of this disclosure. Although examples of robotic links used as a part of a robotic arm are provided herein, aspects of this disclosure also include other types of links (e.g., robotic and non-robotic, medical and non-medical) for which detection of contact with external objects may be desirable.

[0169] FIG. 21A illustrates three views of a distal portion of a robotic arm 201, whereas FIG. 21B illustrates three views of a portion of the robotic arm 201 that is proximal to the distal portion of FIG. 21A. With reference to FIGs. 21A and 21B, the robotic arm 201 may include a device manipulator 203, a plurality of links 205, 207, 209, and 211, and a plurality of joints 213, 215, 217, and 219 connecting the device manipulator 203 and the links 205-211.

In each of the views illustrated in FIG. 21A, regions 221 of the robotic arm 201 which have a relatively higher likelihood of colliding with a patient are highlighted.

[0170] Aspects of this disclosure are directed to an arm component (e.g., one of the robotic links 205-211 or joints 213-219 of FIGs. 21A-21B) that is capable of sensing contact with external objects such as a patient, bedside staff, or other object.

[0171] In certain implementations, a shell can be suspended around a given link and the relative motion between the shell and inner components/members of the link can be detected using one or more sensors in order to detect contact with an external object. FIG. 22 illustrates an example link 300 including a rigid shell 309 and configured to detect contact with external objects in accordance with aspects of this disclosure. In particular, the link 300 includes a structural link 301, a structural cover 303, a first joint 305, a second joint 307, a shell 309, a pair of reaction paddles 311, and a shell cover 313. For example, the inner components of the link 300 may comprise the structural link 301 and the structural cover 303.

[0172] The structural cover 303 can be attached to the structural link 301 to house components of the structural link 301 and form the internal structural connection between the first joint 305 and the second link 305. The shell 309 together with the shell cover 313 are suspended from and surround the structural link 301. As used herein, the shell 309 and shell cover 313 may collectively be referred to simply as the “shell” 309, while the structural link 301 and structural cover 303 may collectively be referred to simply as the structural link 301 or a manipulatable link, unless the context clearly indicates otherwise.

[0173] The shell 309 may be connected to the structural link 301 via a force-sensing connection. Because the shell 309 surrounds the structural link 301, when the link 300 contacts an external object, the object will come into contact with the shell 309. Thus, the force-sensing connection can detect contact between the shell 309 and the external object by measuring changes in the force between the shell 309 and the structural link 301 caused by the link 300 coming into contact with the external object. The shell 309 may also be sufficiently rigid such that, upon contact with an external object, the shell 309 engages the force-sensing connection. Advantageously, by using a rigid shell 309 the force and relative movement between the shell 309 and the structural link 301 can be sensed in all three directions.

[0174] The force-sensing connection may be implemented in a variety of different manners in accordance with aspects of this disclosure. For example, the force-sensing connection can include one or more of the following: traditional load cells, force sensing resistors, and/or any component capable of sensing force (or displacement, when combined with a spring).

[0175] FIG. 23 illustrates one example of a force-sensing connection that can be used in the link 300 of FIG. 22 in accordance with aspects of this disclosure. In particular, the force-sensing connection can include a plurality of shell sensors 321 (e.g., fourteen shell sensors in the illustrated embodiment), which can be disposed between the structural link 301 and the shell 309.

[0176] In some embodiments, the sensors 321 are distributed throughout the link 300 in between the shell 309 and the structural link 301. For example, the shell 309 can be suspended over the structural link 301 via the sensors 321. Depending on the implementation, the link 300 can include one, two, three, four or more sensors 321 distributed along a robotic arm link. FIG. 24A illustrates two views of an embodiment in which fourteen sensors 321 are included in a link 401 in accordance with aspects of this disclosure. In particular, FIG. 24A illustrates a side and front view of one end of the link 401 which includes seven sensors 321. The link 401 may be substantially symmetric at both ends of the link 401, thereby including a total of fourteen sensors 321 in the link 401.

[0177] FIG. 24B illustrates two view of an embodiment in which twelve sensors 321 are included in a link 411 in accordance with aspects of this disclosure. In some implementations, a robotic arm may include the link 401 and the link 411, with the link 401 positioned proximal to the link 411. In particular, FIG. 24B illustrates a side and front view of the link 411 which includes twelve sensors 321. The link 401 may be substantially symmetric at both ends of the link 401, thereby including a total of fourteen sensors 321 in the link 401. In a number of implementations, the plurality of sensors 321 can be configured to support the rigid shell without being fixed to the rigid shell. In some implementations, the link 401, 411 may further include one or more supports configured to support the rigid shell relative to the structural link. For example, the one or more supports can include spring(s), flexure(s), and/or suspension(s).

[0178] Although FIGs. 24A and 24B illustrate embodiments of links 401, 411 including a plurality of sensors 321, in other implementations the link can include a single sensor configured to sense force and/or displacement between the structural link 301 and the shell 309 in multiple directions. Using signals received from the sensor(s) 321, the robotic system can be configured to detect a direction of the contact between the shell 309 and the external object. The robotic system can also measure a magnitude of a force resulting from the contact between the shell 309 and the external object based on the signal from the sensor(s) 321. Based on the placement of the plurality of sensors 321 within the links 401 and 411, the robotic system can also be configured to detect a torque applied to the link. For example, if a

torque is applied to the shell 309, certain sensors 321 on one side of the link 401, 411 may be compressed. Based on the positions of and forces sensed by the sensors 321 being compressed, the robotic system can determine a torque applied to the link 401, 411.

[0179] FIG. 25 is a flowchart illustrating an example method 500 operable by a surgical robotic system, or component(s) thereof, for detecting contact between a robotic arm/manipulator and an external object in accordance with one or more aspects of this disclosure. It is to be appreciated that the steps of method 500 illustrated in FIG. 25 may be performed by one or more processors of a surgical robotic system. For convenience, the method 500 is described as performed by a processor of the system.

[0180] The processor may be included as a part of a system, including a robotic manipulator including a link, a rigid shell configured to overlay the link, and one or more sensors positioned between the rigid shell and the link. The one or more sensors are configured to detect contact between one or more external objects and the rigid shell in at least two or more directions. The system may further include at least one computer-readable memory in communication with the processor and having stored thereon computer-executable instructions to cause the set of processors to perform the method 500.

[0181] The method 500 may begin at block 501. At block 502, the processor may receive a signal from the one or more sensors positioned between the manipulatable link of the robotic manipulator and the rigid shell configured to overlay the link. The received signal is indicative of the degree of contact between the rigid shell and the one or more sensors.

[0182] At block 504, the processor may determine that contact between the robotic manipulator and the external object has occurred in response to the received signal meeting or exceeding a threshold value. In some implementations, the processor can also detect a direction of the contact between the rigid shell and the external object based on the received signal. The processor can also measure a magnitude of a force and/or torque resulting from the contact between the rigid shell and the external object based on information in the signal (e.g., data in the time or frequency domain) received from the one or more sensors. The processor may also be configured to measure a direction of relative motion between the rigid shell and the link based on the received signal.

[0183] In certain embodiments, the processor may also be configured to determine the location in space of the external object based on signal(s) from sensor(s) indicative of the detected contact and prevent movement of the robotic arm (or other robotic arms) to the location of the contact by updating a collision model to avoid future contact in the same area. Such information may include which sensors are activated by the contact and/or directional

information detected by a given sensor. As used herein, a collision model may be a model of object(s) within the environment which may be at risk of a collision with the robotic arms. The robotic system can prevent movement of the robotic arms which would result in collisions with object(s) modeled in the collision model. The method 500 may end at block 506.

[0184] The one or more sensors 321 that are provided in the link 300, 401, or 411 can include: traditional load cells, force sensing resistors, strain gauges, and/or capacitive sensors, etc. In one implementation, the one or more sensors 321 comprise beam flexure type sensors 600 (also referred to a spring or diving board sensor). FIG. 26 illustrates an embodiment of a beam flexure sensor 600 in accordance with aspects of this disclosure. In this implementation, the sensor 600 comprises a beam flexure 601 configured to contact an underlying force sensor 603. Upon a force being applied to the shell 309, the shell applies a force to the sensor through the beam flexure 601 which then applies a force to the force sensor 603 (which may be scaled from the original force). Such motions (which can include micromotions) will therefore allow the sensor 603 to detect that contact with an external object has occurred. Based on the detection of contact with an external object, the robotic system can take actions (e.g., stop motion of the robotic arm) to reduce the contact or prevent further contact.

[0185] FIG. 27 illustrates another embodiment of a beam flexure sensor 700 in accordance with aspects of this disclosure. In this implementation, the sensor 700 comprises a beam flexure 701 that is configured to contact an underlying force sensor 703, and a contact point 705 at which the beam flexure 701 is configured to contact the shell 309. Although not illustrated, the sensor 700 can further include a circuit board configured to receive an output signal from the force sensor 703 and output a signal indicative of the force applied to the contact point 705. In some implementations, the force sensor 703 may be mounted on the circuit board. The beam flexure 701 may comprise a first end (e.g., on the left side of FIG. 27) that is fixed and a second end (e.g., on the right side of FIG. 27) coupled to the force sensor 703. The contact point 705 is located between the first and second ends of the beam flexure 701. Accordingly, the force exerted on the force sensor 703 is proportional to or otherwise indicative of the force applied to the contact point 705. In combination with the contact point 705, the beam flexure 701 can be configured to scale a force applied to the sensor 700 and isolate the sensor 703 from shear forces applied to the shell 309. In certain implementations, the contact point 705 may function as a load concentrator configured to control a point at which the shell 309 applies a force to the sensor 700 (e.g., the point at which the force is applied to the beam flexure 701).

[0186] The specific location of the contact point 705 between the first and second ends will affect the amount of leverage provided by contact of an external object with the shell 309 onto the force sensor 703. For example, when the contact point 705 is located closer to the second end with the force sensor 703, more of the force applied to the contact point 705 will be transmitted to the force sensor 703 than when the contact point 705 is located closer to the fixed first end. Thus, the location of the contact point 705 can be selected to map the range of forces expected to be received by the shell 309 onto the range of forces detectable by the force sensor 703. By reducing the forces using the beam flexure 701, the force sensor 703 can effectively measure greater forces applied to the shell 309 by reducing the received force onto the range of forces measurable by the force sensor 703.

[0187] Aspects of this disclosure provide a number of advantages for the detection of contact between a link and an external object. For example, aspects of this disclosure are advantageous over systems that measure torque (either directly with a torque sensor, or through current or control loop disturbances) as the sensitivity of implementation of this disclosure do not decrease as the applied force vector approaches the torque axis, as is the case in torque sensing systems. Similarly, systems that mount the entire robot on load cells (as is common in some industrial robots) may have similar drawbacks to torque-based measurement systems.

[0188] Additionally, by using a shell 309 to detect contact with an external object as described herein, the system can advantageously sense contact on the entire surface of the link. In contrast, implementations which employ a film to sense contact may not be able to sense or detect contact with an external object at locations where the film is not applied to the link(s).

[0189] Another advantage of aspects of this disclosure includes allowing for the system to sense the total amount of contact force over the entire surface of a given link, to allow a certain amount of light incidental contact without interrupting a medical procedure. This is advantageous over systems that are not able to distinguish between a small amount of incidental force and larger forces that risk injury and/or damage.

[0190] Yet another advantage of aspects of this disclosure is the compact form factor enabled by the shell compared to systems that surround the robot in pressure-sensitive gas-filled bladders.

Contact Detection Using a Film

[0191] In certain implementations, a coating or film of sensors can be adhered to a surface of a link (e.g., a robotic arm link). FIG. 28 illustrates an example robotic link 800 that

can form a portion of a robotic arm in accordance with aspects of this disclosure. In particular, the link 800 includes a structural link 801 and a film 803 applied to an external surface of the structural link 801. Depending on the implementation, the film 803 can comprise various types of force sensors. For example, technologies which can be used in the film 803 include: force sensing resistors (FSR), capacitive sensors, proximity sensors, and/or others.

[0192] In certain implementations, the film 803 may be attached to surfaces of the link 800 that are more likely to contact external objects (e.g., the regions 221 illustrated in FIGs. 21A and 21B). By detecting contact with external objects using the film 803, the robotic system can respond to the detected contact to prevent applying an unacceptably high load onto the external object (e.g., an inanimate object such as medical accessories or a bed, beside staff, or the patient).

[0193] By applying such a film 803 to a robotic arm, the robotic system can detect contact between an external object and the robotic arm and prevent further movement in the direction of the contact with the external object. In addition, the robotic system can also determine the location in space of the external object based on the detected contact and prevent movement of the robotic arm (or other robotic arms) to the location of the contact by updating a collision model to avoid future contact in the same area. The robotic system can prevent movement of the robotic arms which would result in collisions with object(s) modeled in the collision model.

[0194] The use of a force sensing film 803 in accordance with aspects of this disclosure allows for the maximization of a robot's collision free workspace by allowing the robot (e.g., a robotic arm) to move until it collides with an external object and then stop. This allows for a larger workspace than might otherwise be feasible with force sensing solutions that occupy a larger volume around the structural link (e.g., systems that surround the robot in pressure-sensitive gas-filled bladders).

[0195] In contrast to systems that use force or torque sensors positioned in robotic arm joints, aspects of this disclosure which employ force sensing films do not experience a decrease as the applied force vector approaches the torque axis, as is the case in torque sensing systems. Similarly, systems that mount the entire robot on load cells (as is common in some industrial robots) may have similar drawbacks to torque-based measurement systems.

[0196] The advantage of an increased collision-free workspace is also apparent compared to systems which artificially limiting a robot's workspace such that it can never contact the patient or accessories. Since such artificial limitations cannot precisely define the locations of external objects, implementations which use such artificial limitations can

dramatically limit the workspace and cause user irritation due to unachievable movements and/or poses of the robotic arms. In related aspects, force sensing film 803 may be used in conjunction with one or more sensors 321 that are provided in a manipulatable link, wherein the one or more sensors can include: traditional load cells, force sensing resistors, strain gauges, and/or capacitive sensors, etc.

4. Implementing Systems and Terminology.

[0197] Implementations disclosed herein provide systems, methods and apparatus for detecting contact between a link and an external object.

[0198] It should be noted that the terms “couple,” “coupling,” “coupled” or other variations of the word couple as used herein may indicate either an indirect connection or a direct connection. For example, if a first component is “coupled” to a second component, the first component may be either indirectly connected to the second component via another component or directly connected to the second component.

[0199] The detection of contact between a link and an external object functions described herein may be stored as one or more instructions on a processor-readable or computer-readable medium. The term “computer-readable medium” refers to any available medium that can be accessed by a computer or processor. By way of example, and not limitation, such a medium may comprise random access memory (RAM), read-only memory (ROM), electrically erasable programmable read-only memory (EEPROM), flash memory, compact disc read-only memory (CD-ROM) or other optical disk storage, magnetic disk storage or other magnetic storage devices, or any other medium that can be used to store desired program code in the form of instructions or data structures and that can be accessed by a computer. It should be noted that a computer-readable medium may be tangible and non-transitory. As used herein, the term “code” may refer to software, instructions, code or data that is/are executable by a computing device or processor.

[0200] The methods disclosed herein comprise one or more steps or actions for achieving the described method. The method steps and/or actions may be interchanged with one another without departing from the scope of the claims. In other words, unless a specific order of steps or actions is required for proper operation of the method that is being described, the order and/or use of specific steps and/or actions may be modified without departing from the scope of the claims.

[0201] As used herein, the term “plurality” denotes two or more. For example, a plurality of components indicates two or more components. The term “determining”

encompasses a wide variety of actions and, therefore, “determining” can include calculating, computing, processing, deriving, investigating, looking up (e.g., looking up in a table, a database or another data structure), ascertaining and the like. Also, “determining” can include receiving (e.g., receiving information), accessing (e.g., accessing data in a memory) and the like. Also, “determining” can include resolving, selecting, choosing, establishing and the like.

[0202] The phrase “based on” does not mean “based only on,” unless expressly specified otherwise. In other words, the phrase “based on” describes both “based only on” and “based at least on.”

[0203] The previous description of the disclosed implementations is provided to enable any person skilled in the art to make or use the present invention. Various modifications to these implementations will be readily apparent to those skilled in the art, and the generic principles defined herein may be applied to other implementations without departing from the scope of the invention. For example, it will be appreciated that one of ordinary skill in the art will be able to employ a number corresponding alternative and equivalent structural details, such as equivalent ways of fastening, mounting, coupling, or engaging tool components, equivalent mechanisms for producing particular actuation motions, and equivalent mechanisms for delivering electrical energy. Thus, the present invention is not intended to be limited to the implementations shown herein but is to be accorded the widest scope consistent with the principles and novel features disclosed herein.

WHAT IS CLAIMED IS:

1. A robotic system, comprising:
a manipulatable link;
a rigid shell configured to overlay the manipulatable link; and
one or more sensors positioned between the rigid shell and the manipulatable link, the one or more sensors configured to detect contact between the rigid shell and one or more external objects.
2. The robotic system of Claim 1, wherein at least one of the one or more sensors comprises a beam flexure.
3. The robotic system of Claim 2, wherein the beam flexure is configured to engage with an underlying force sensor.
4. The robotic system of Claim 1, wherein the manipulatable link comprises a link of a robotic arm.
5. The robotic system of Claim 4, wherein the manipulatable link comprises a first link or a second link of the robotic arm.
6. The robotic system of Claim 5, wherein at least two or more sensors are located along the proximal link or the distal link of the robotic arm for sensing contact between the one or more external objects and the respective link.
7. The robotic system of Claim 1, wherein the one or more external objects comprise a patient, clinician, or inanimate object.
8. The robotic system of Claim 1, wherein the rigid shell is suspended over the manipulatable link via the one or more sensors.
9. The robotic system of Claim 1, wherein the one or more sensors are further configured to detect a direction of the contact between the rigid shell and the one or more external objects.
10. The robotic system of Claim 9, wherein the one or more sensors are further configured to measure a magnitude of a force resulting from the contact between the rigid shell and the one or more external objects.

11. The robotic system of Claim 1, wherein the one or more sensors comprise a first set of one or more sensors and a second set of one or more sensors, the first set of one or more sensors positioned between the rigid shell and the manipulatable link at a proximal end of the manipulatable link, and the second set of one or more sensors positioned between the rigid shell and the manipulatable link at a distal end of the manipulatable link.
12. The robotic system of Claim 1, wherein the one or more sensors are further configured to detect a direction of the contact between the rigid shell and the one or more external objects.
13. The robotic system of Claim 1, wherein the one or more sensors are further configured to measure a magnitude of a force resulting from the contact between the rigid shell and the one or more external objects.
14. The robotic system of Claim 1, wherein the one or more sensors are further configured to measure a torque resulting from the contact between the rigid shell and the one or more external objects.
15. The robotic system of Claim 1, wherein the one or more sensors are further configured to measure a direction of relative motion between the rigid shell and the link.
16. A sensor assembly for detecting contact with a manipulatable link of a robotic system, the sensor assembly comprising:
 - a beam flexure;
 - an underlying force sensor for detecting contact with the manipulatable link;
 - and
 - a circuit board.
17. The sensor assembly of Claim 16, wherein the beam flexure comprises a first end that is fixed and a second end engaged to the force sensor.
18. The sensor assembly of Claim 17, wherein the beam flexure is engaged with a rigid shell at a point between the first end and the second end.
19. The sensor assembly of Claim 18, wherein the force exerted on the sensor is proportional to the force applied to the point at which the shell engages the flexure.

20. The sensor assembly of Claim 16, wherein the beam flexure is engaged with a rigid shell at a fixed point along the beam flexure.

21. The sensor assembly of Claim 20, wherein a processor is configured to receive an output from the force sensor and generate a force value indicative of a force applied to the rigid shell.

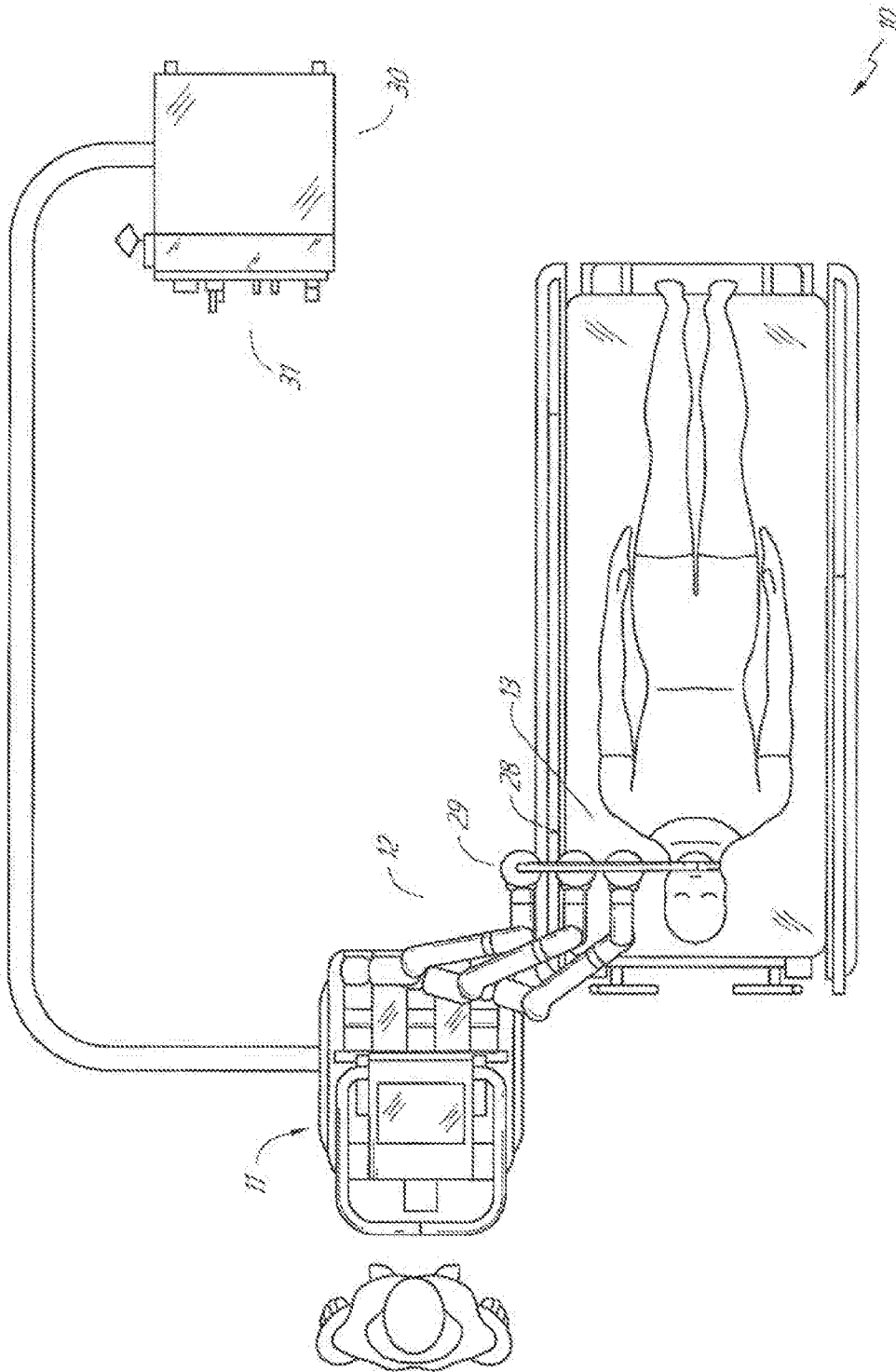

FIG. 1

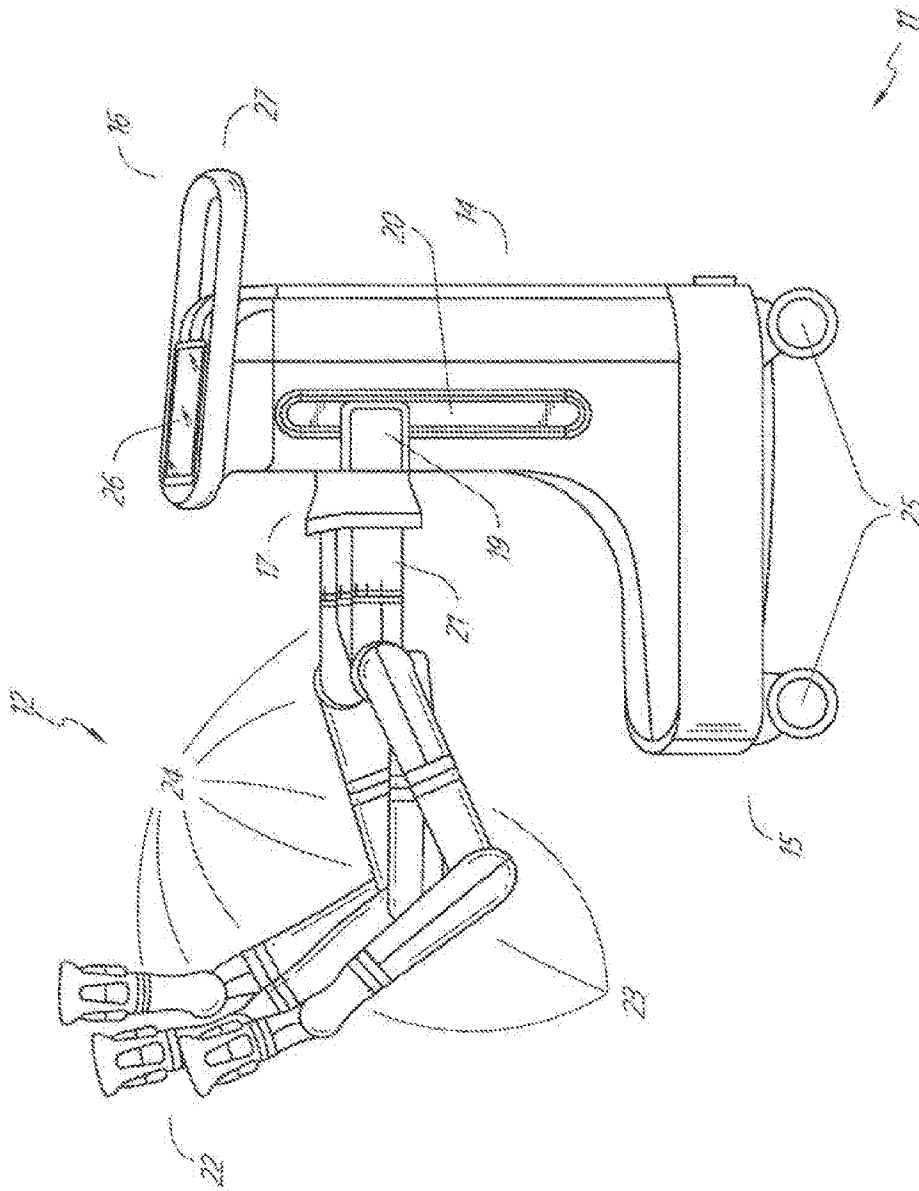

FIG. 2

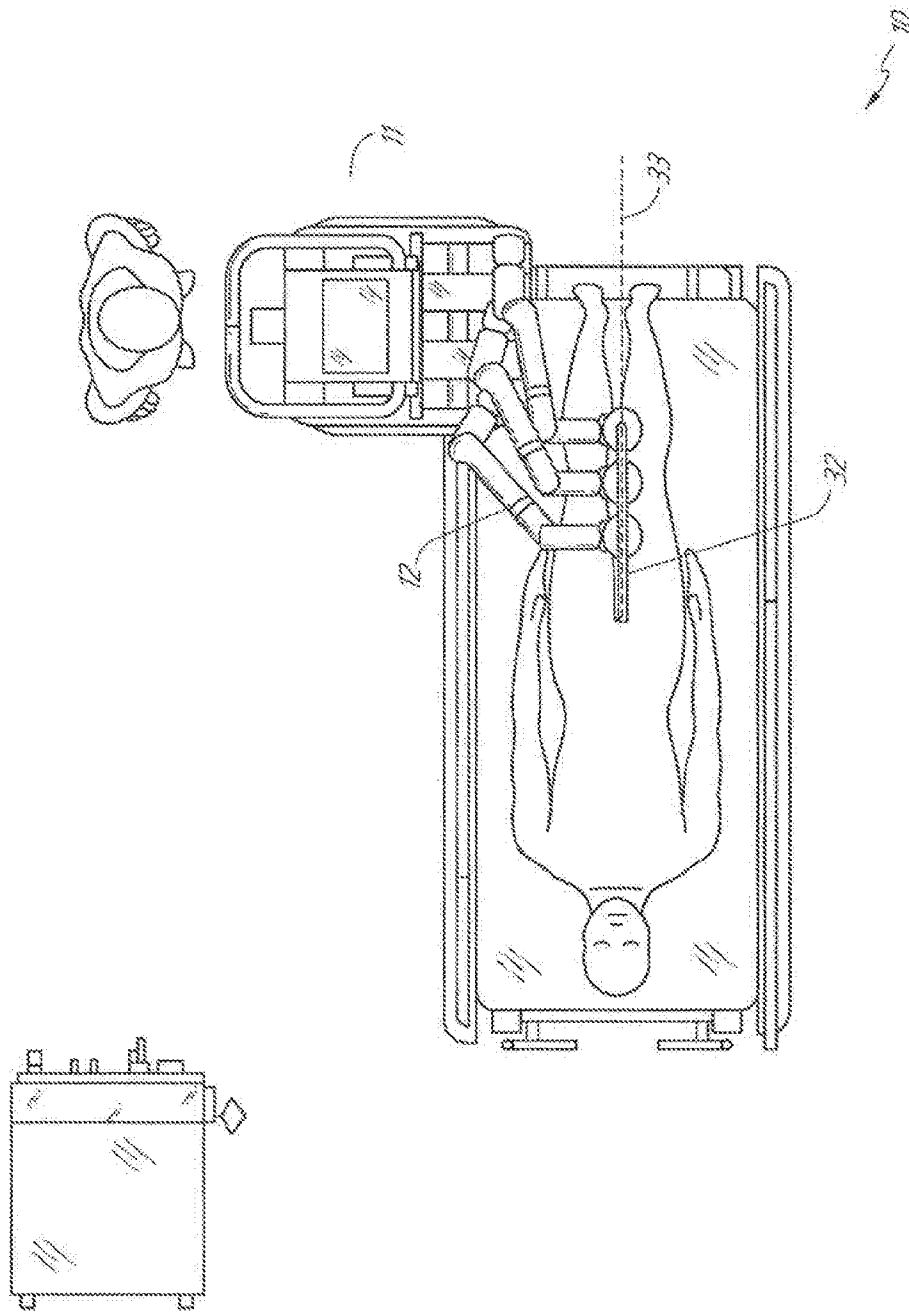

FIG. 3

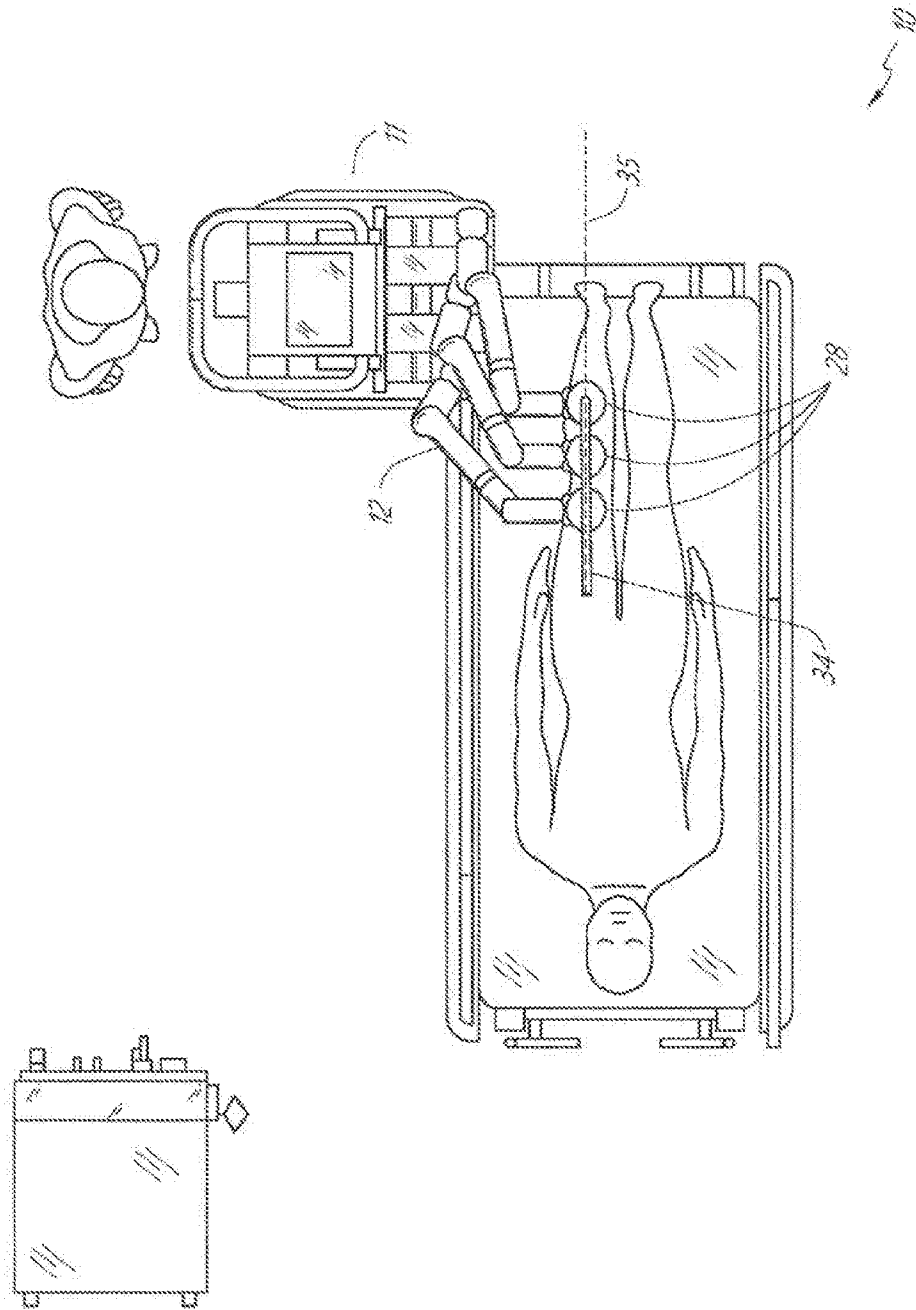

FIG. 4

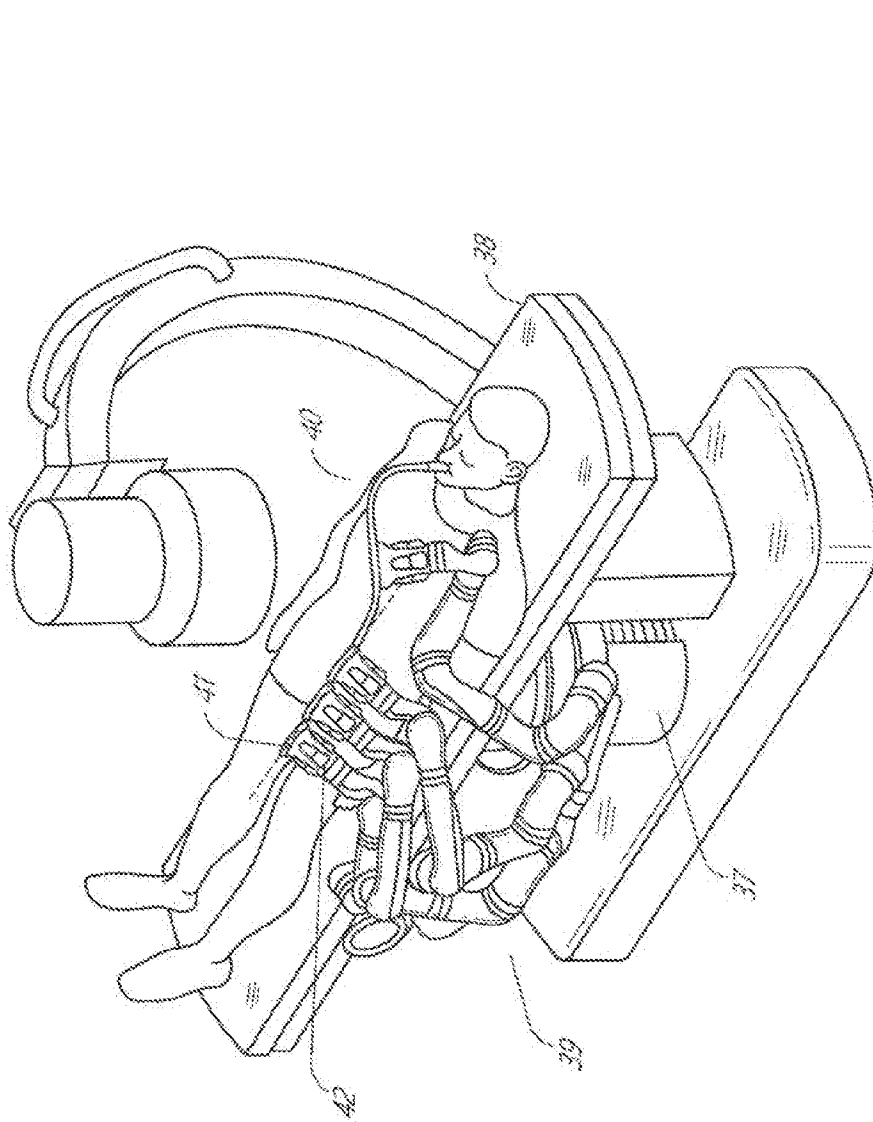

FIG. 5

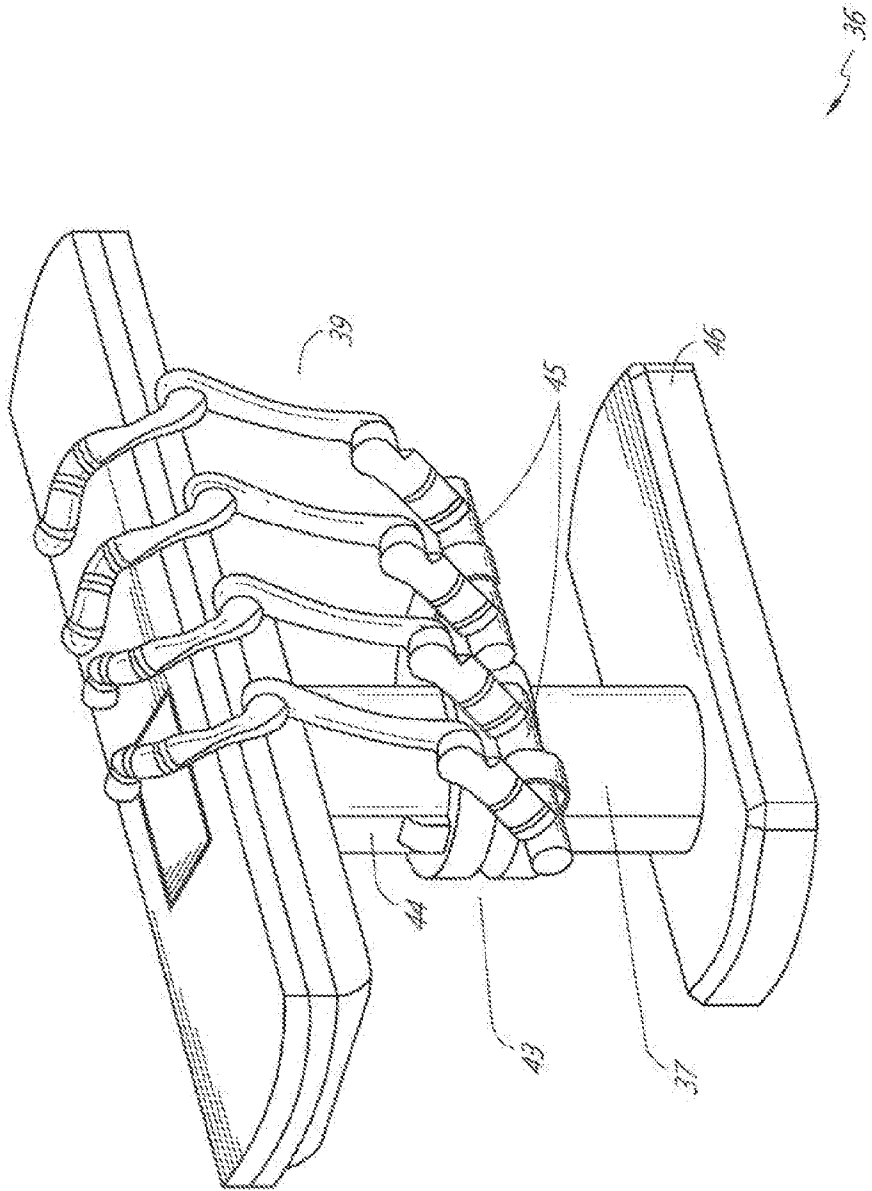

FIG. 6

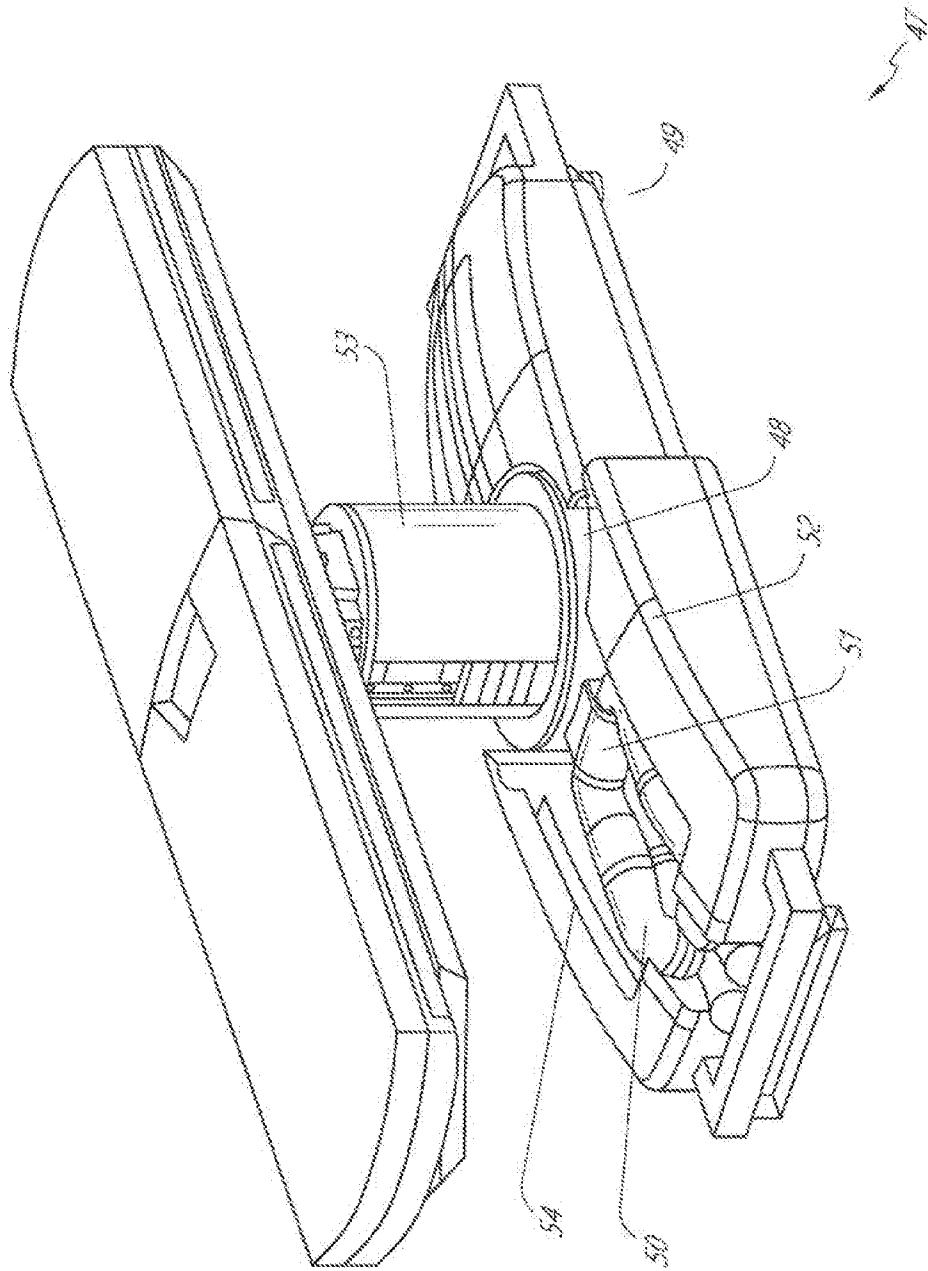

FIG. 7

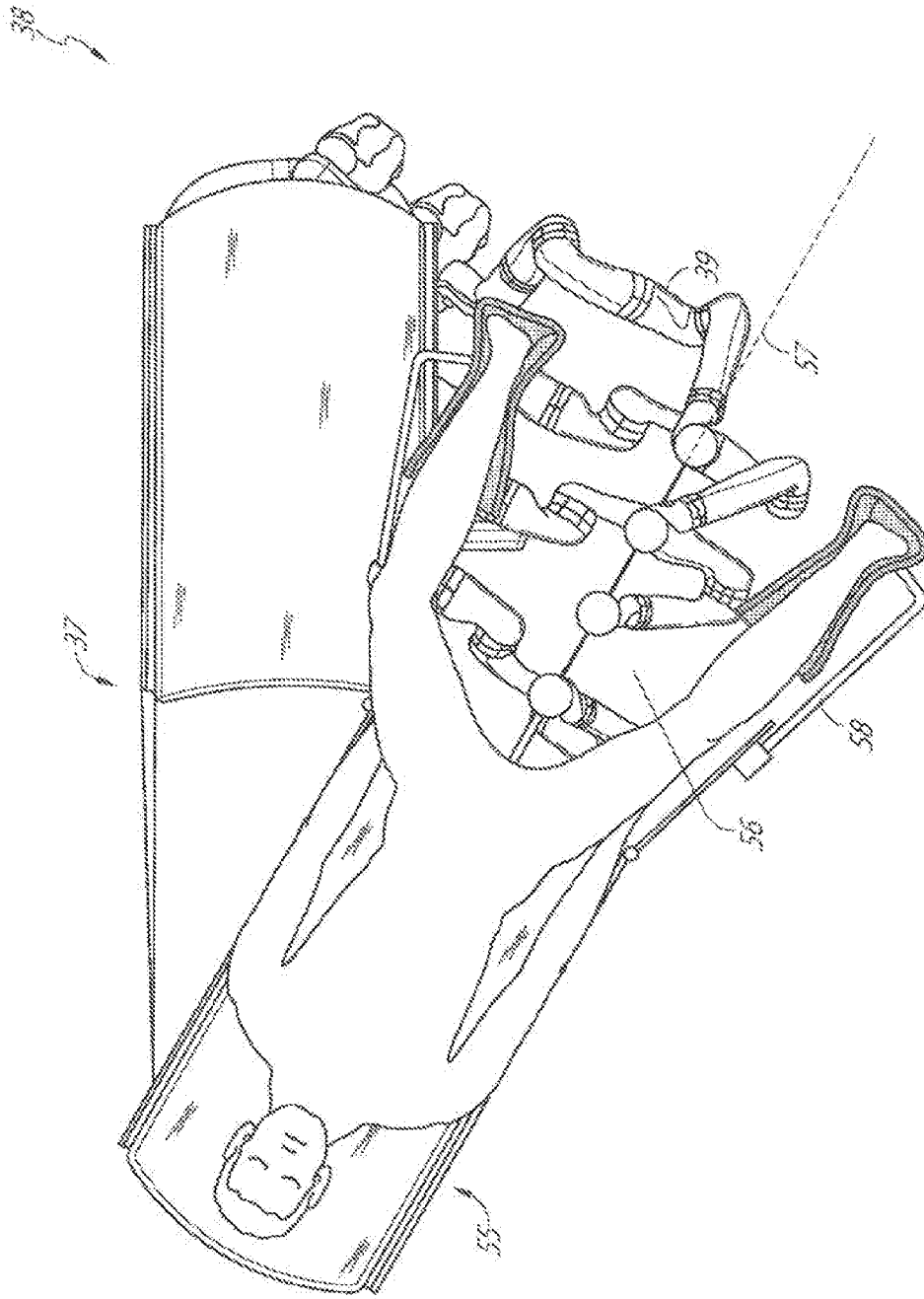
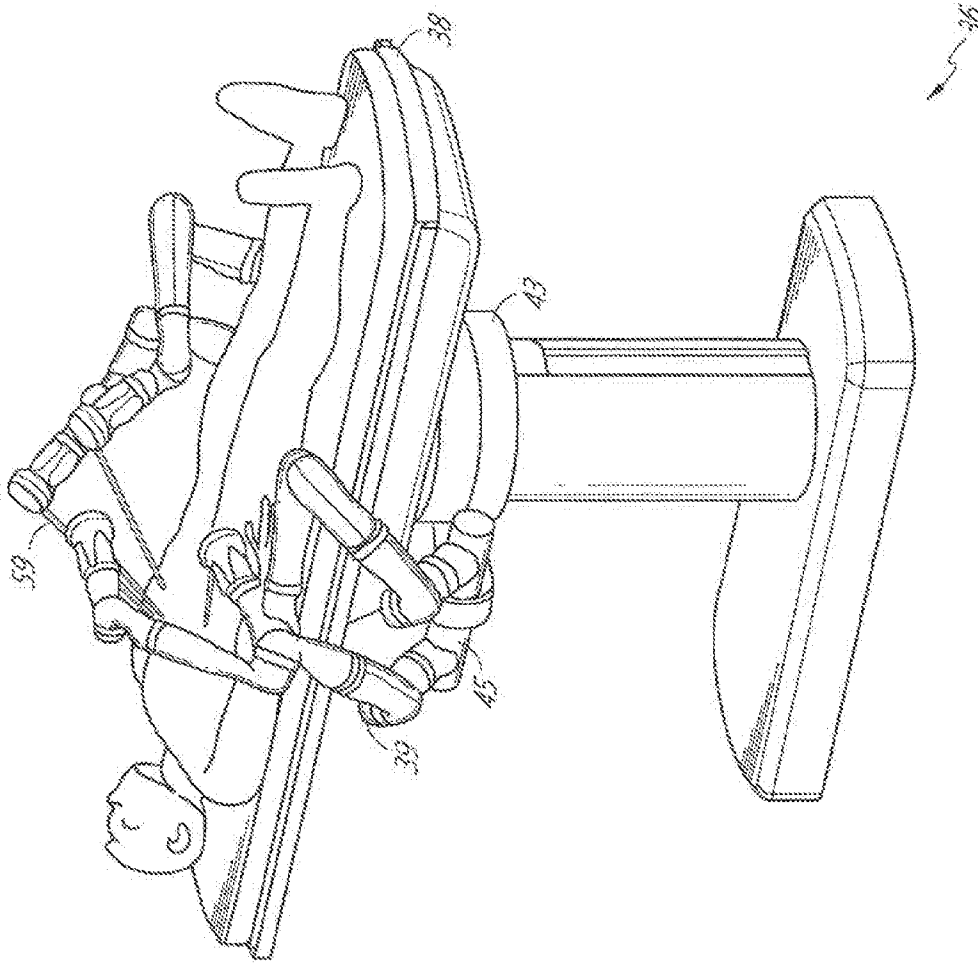

FIG. 8



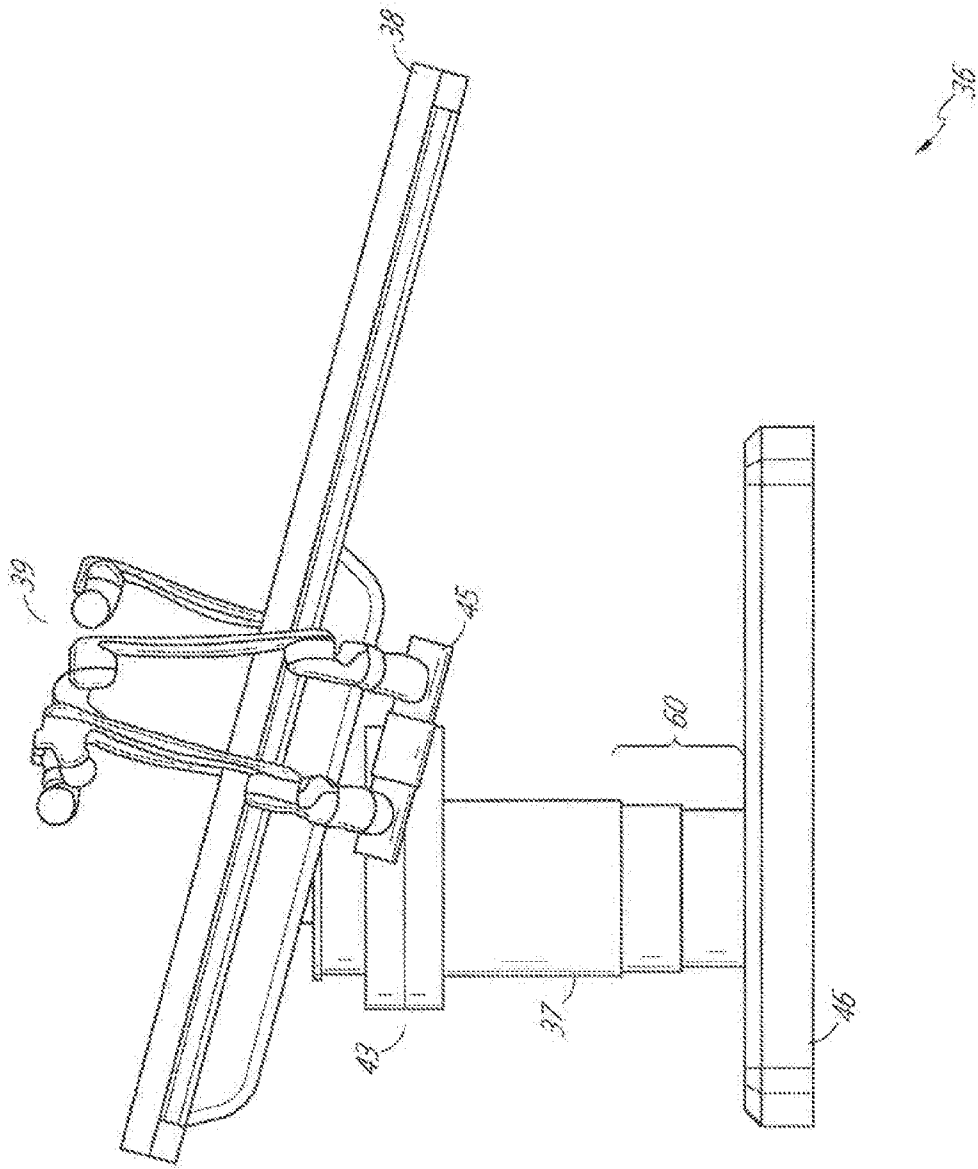

FIG. 10

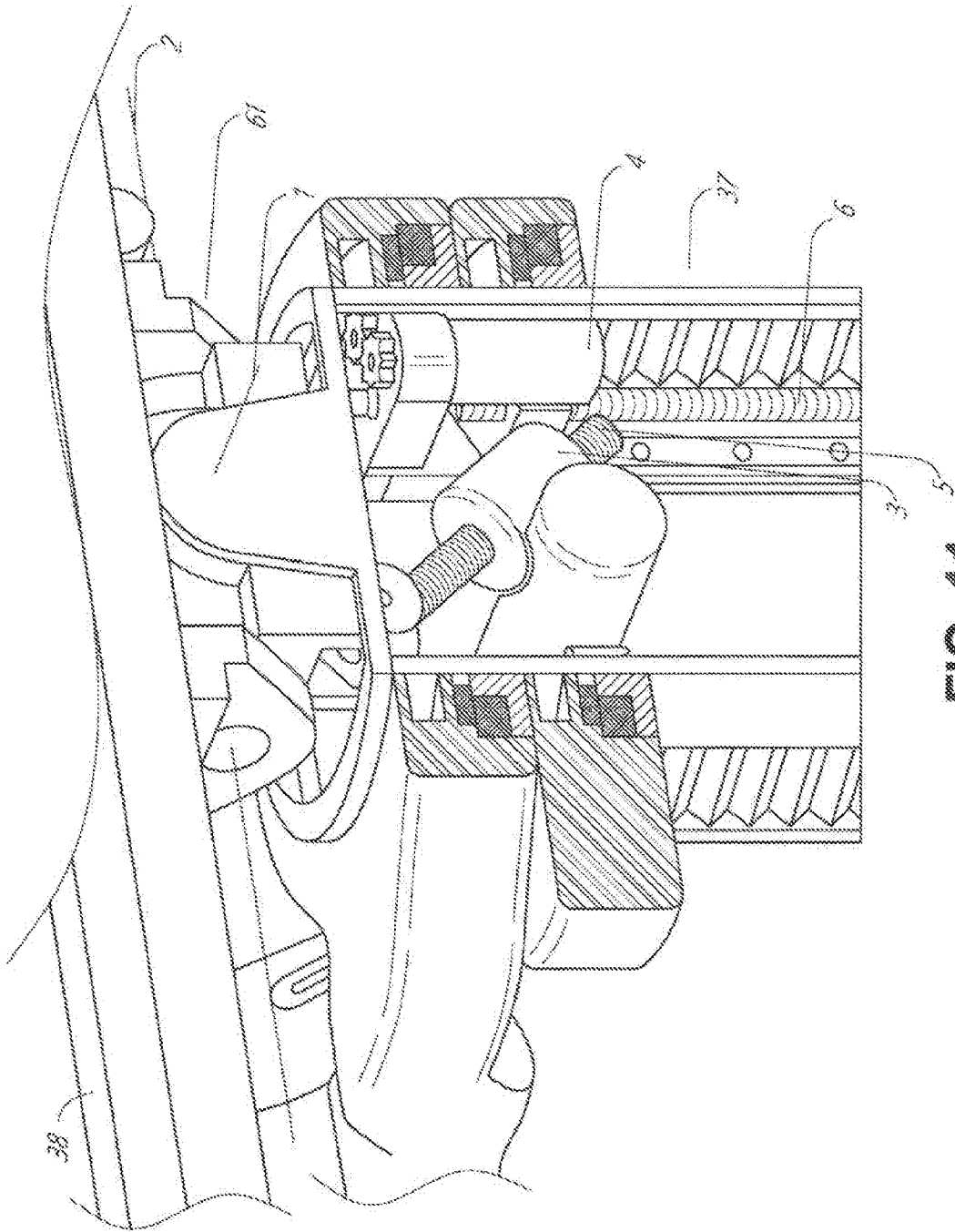

FIG. 11

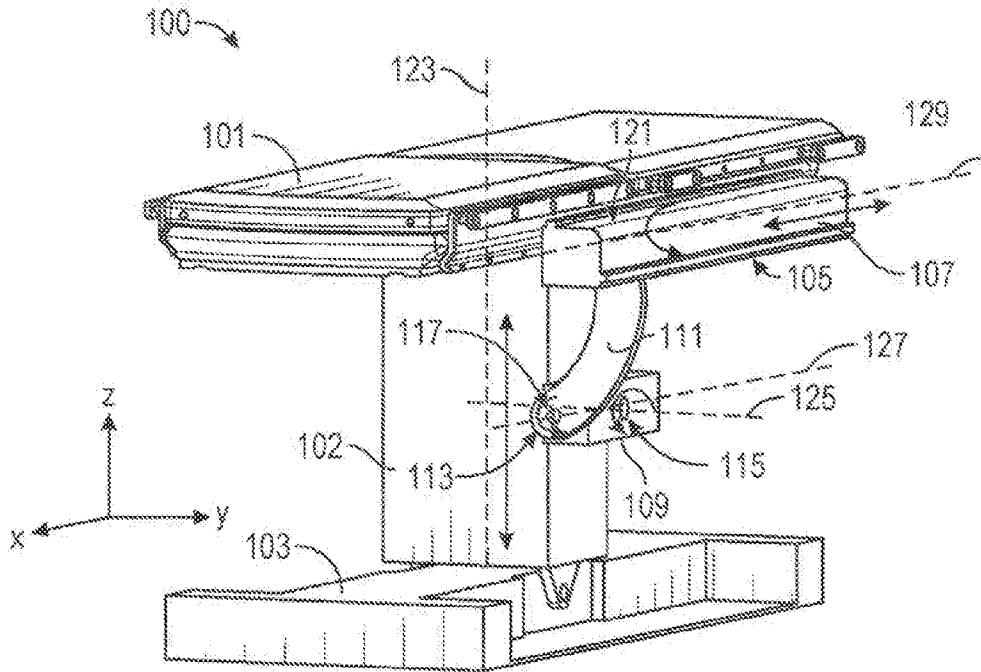

FIG. 12

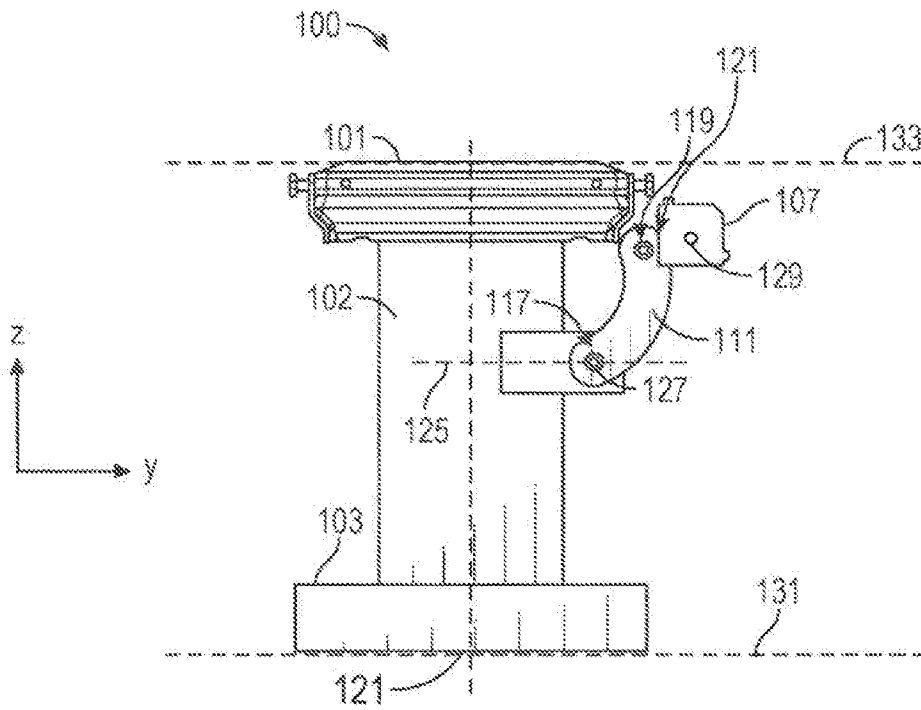

FIG. 13

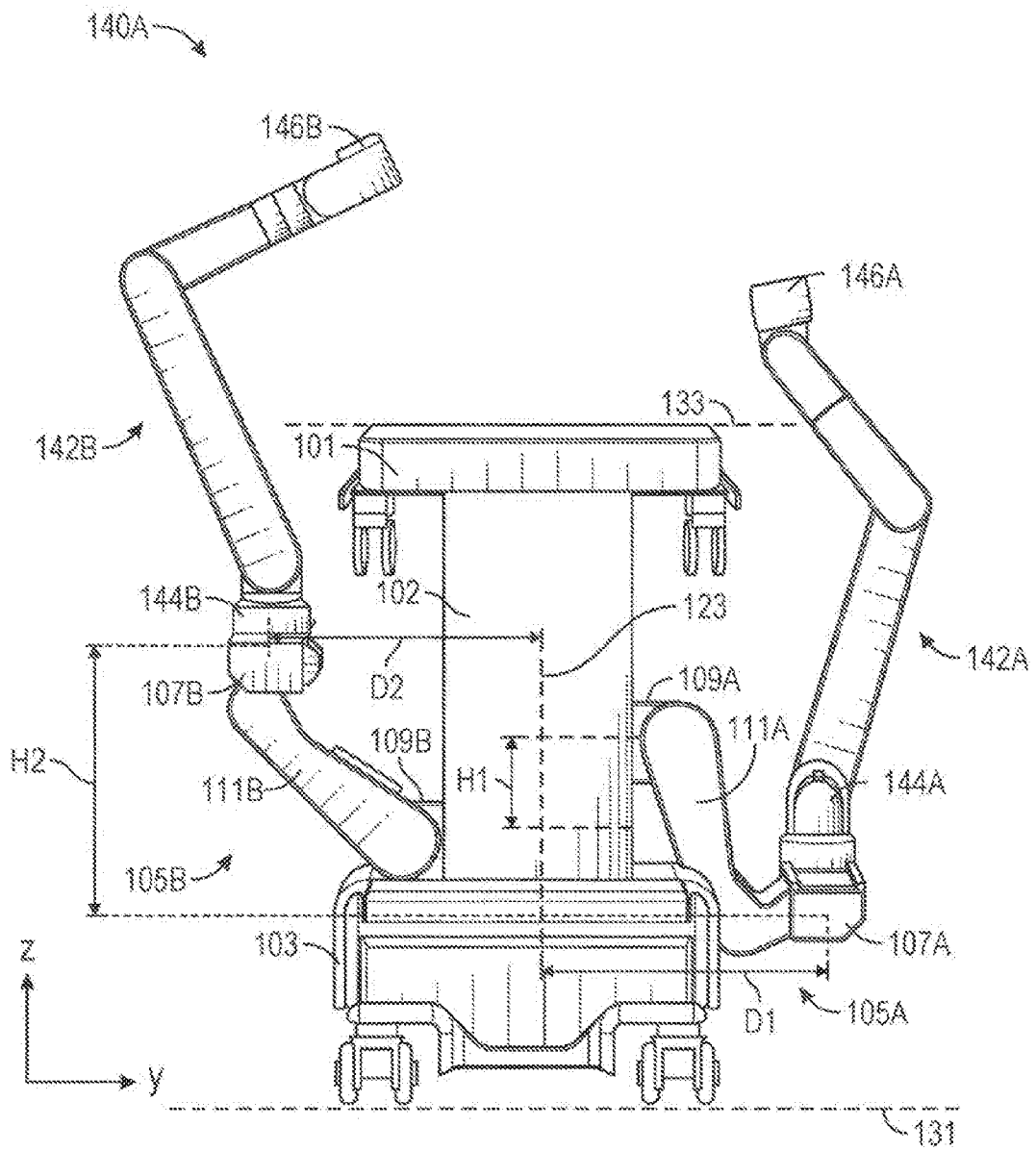

FIG. 14

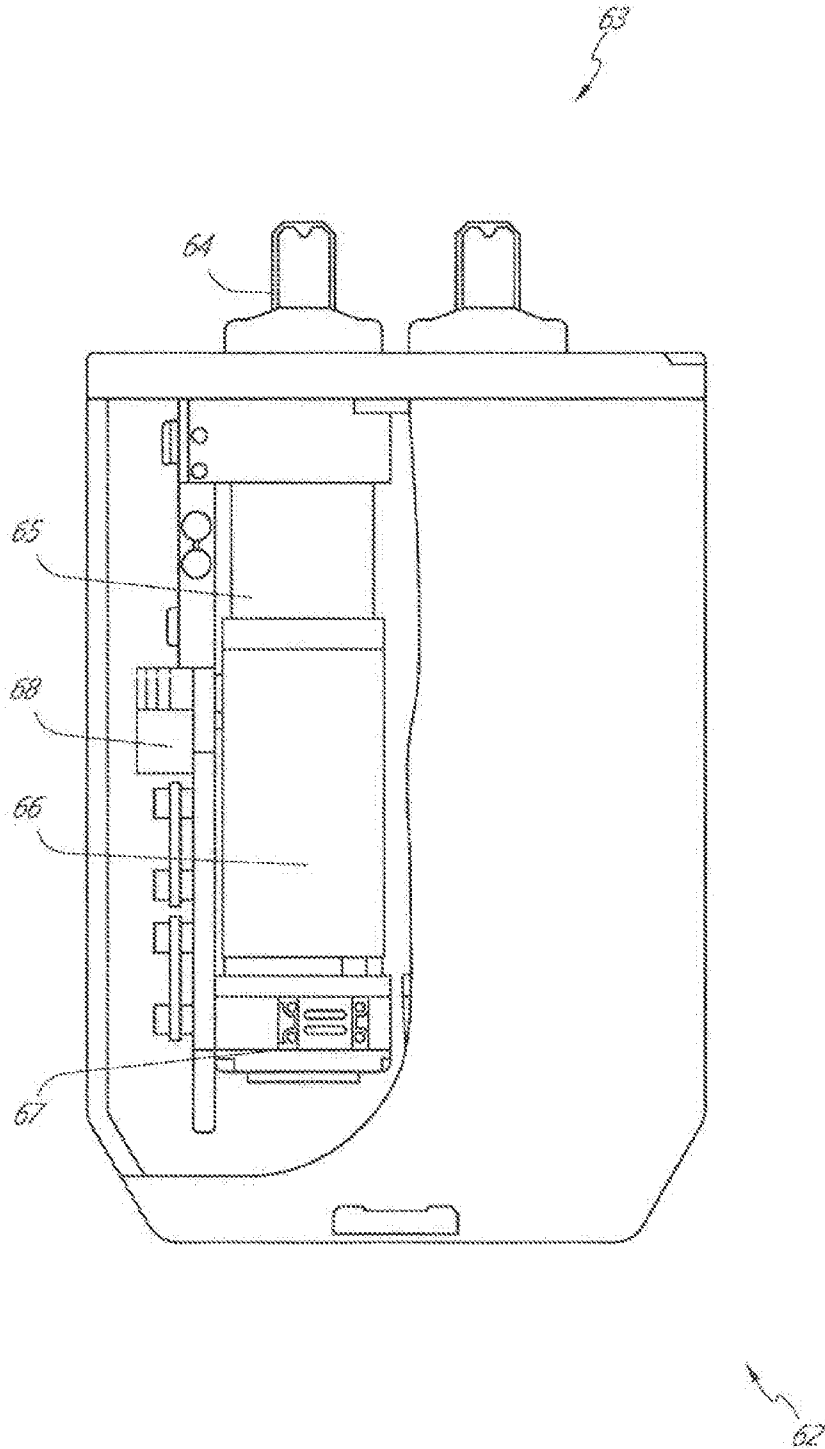

FIG. 15

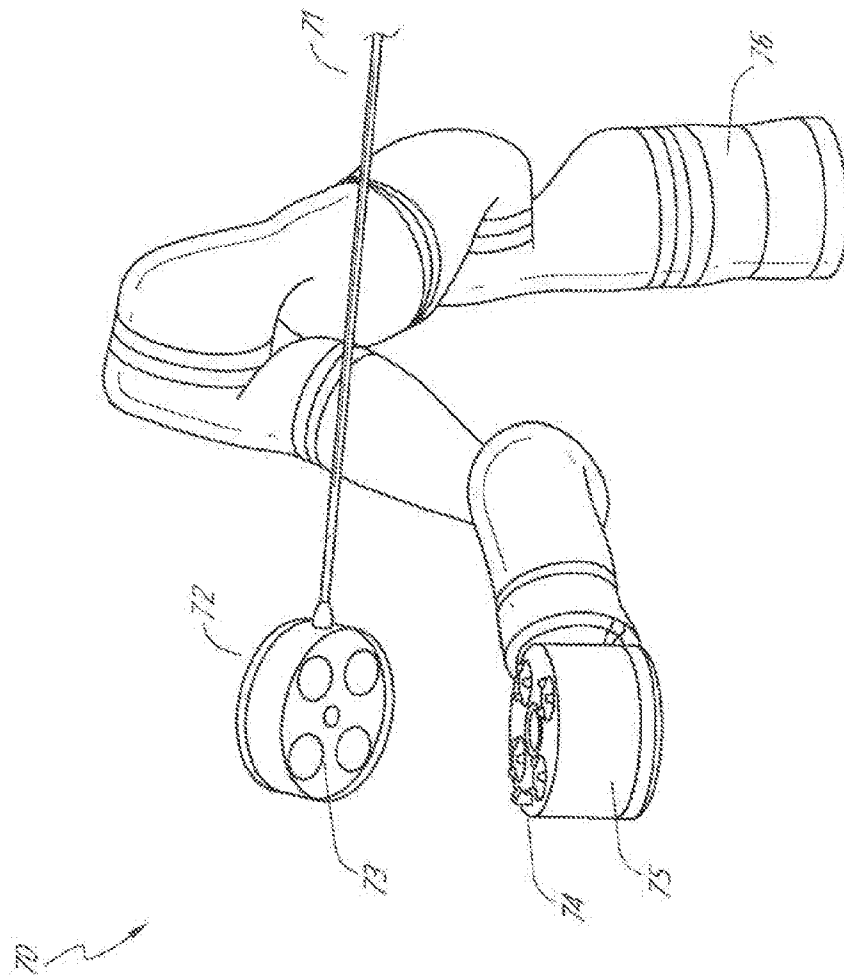

FIG. 16

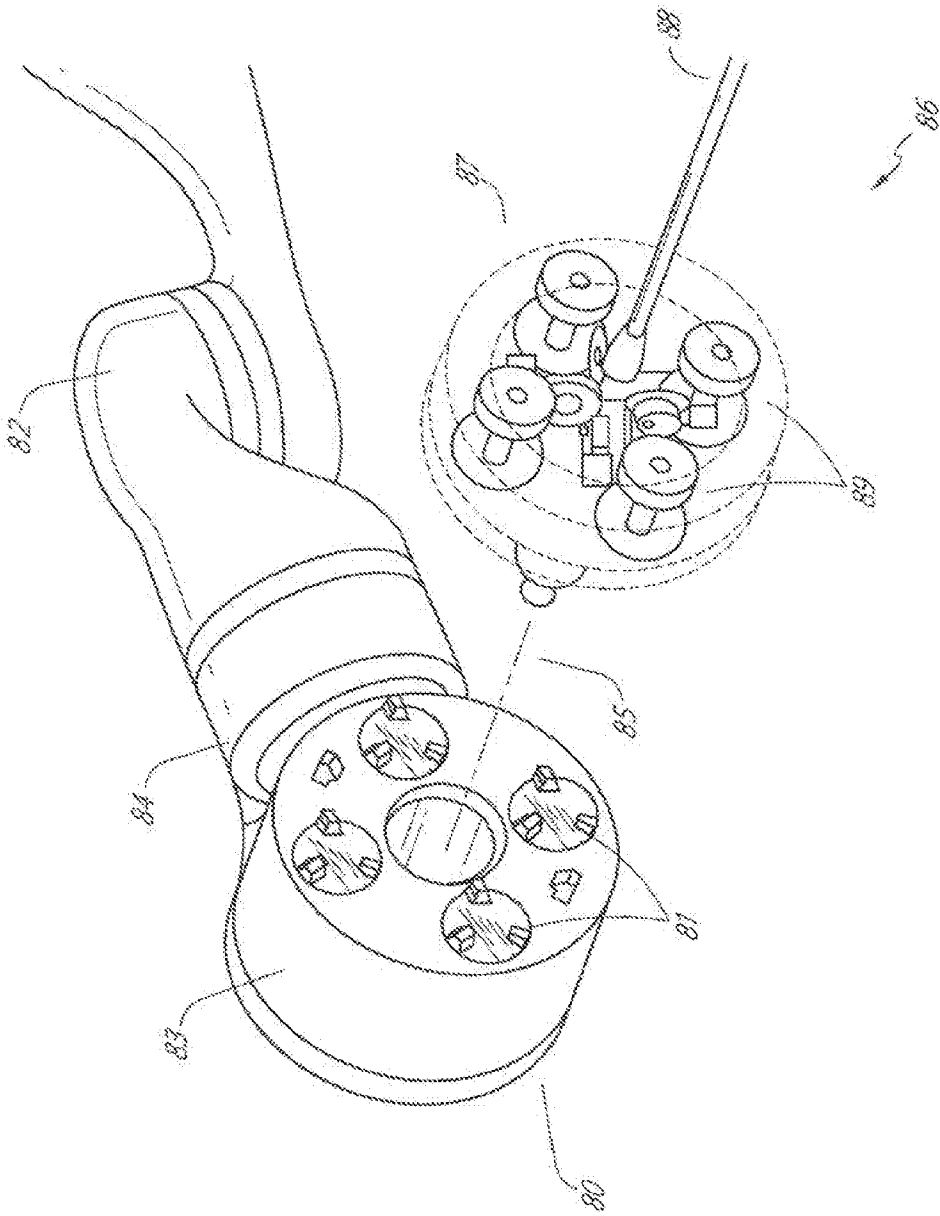

FIG. 17

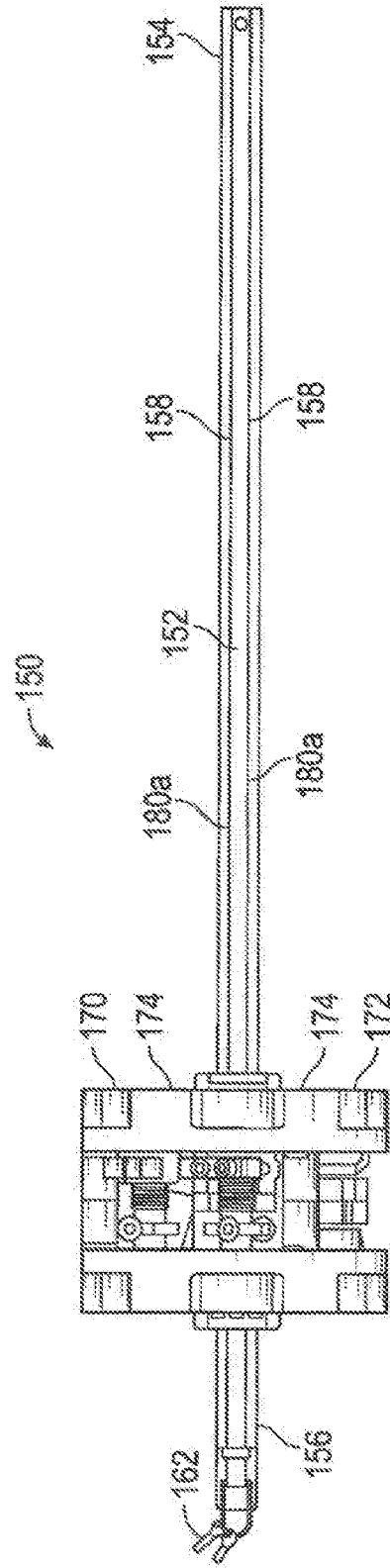

FIG. 10

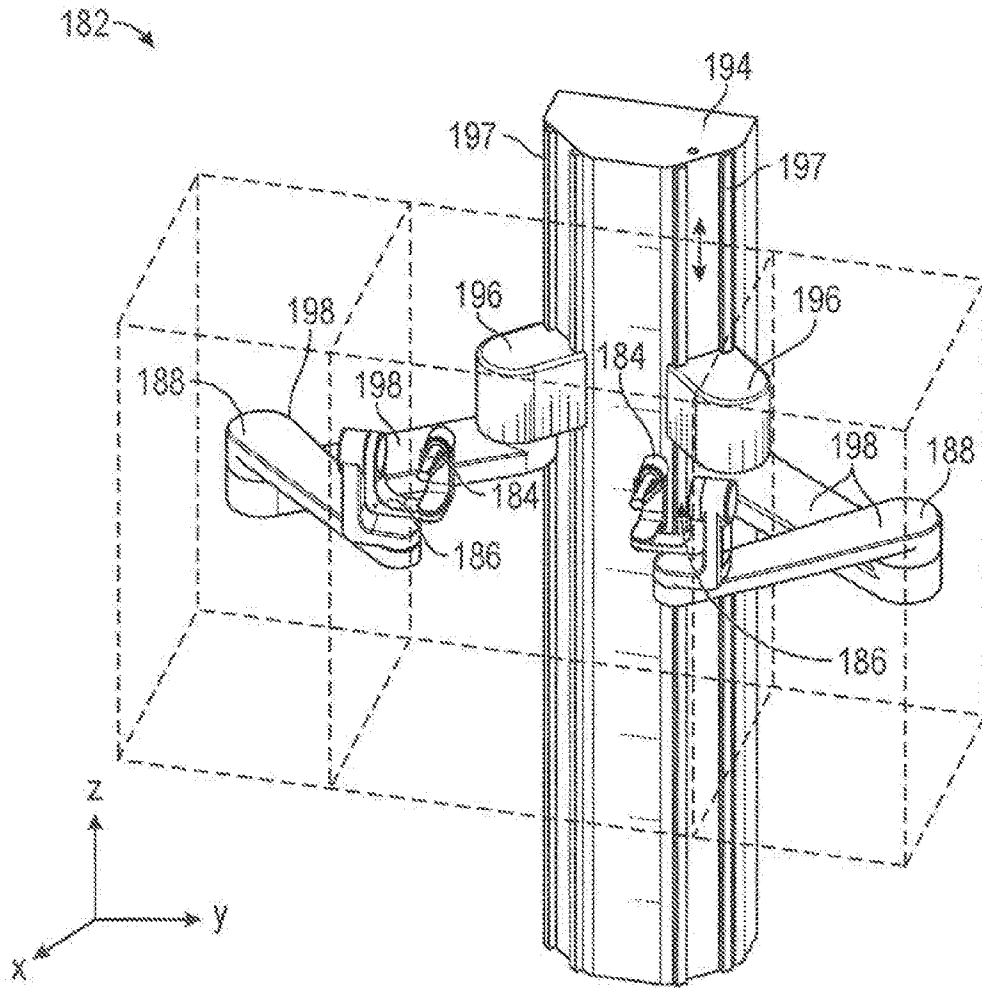

FIG. 19

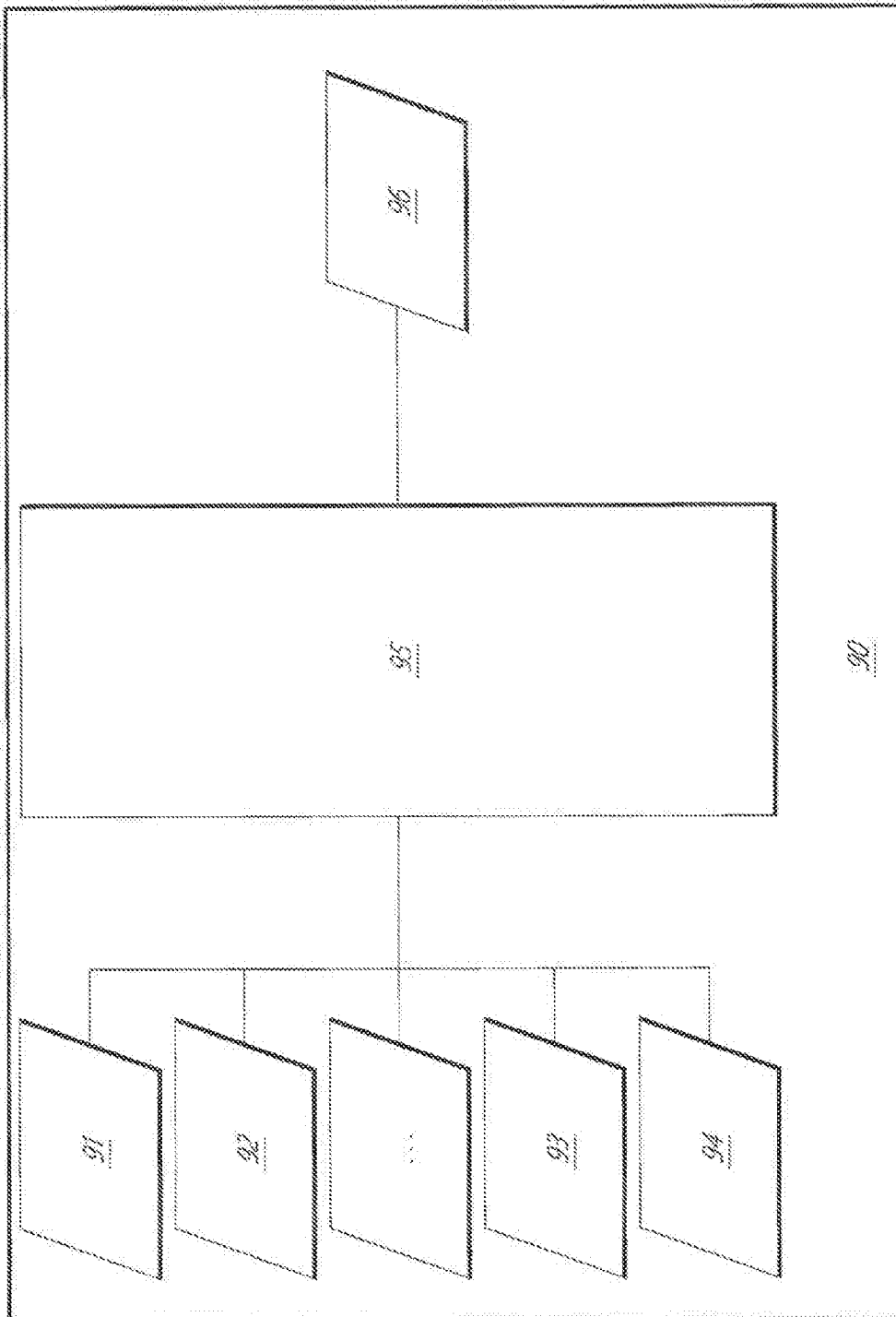
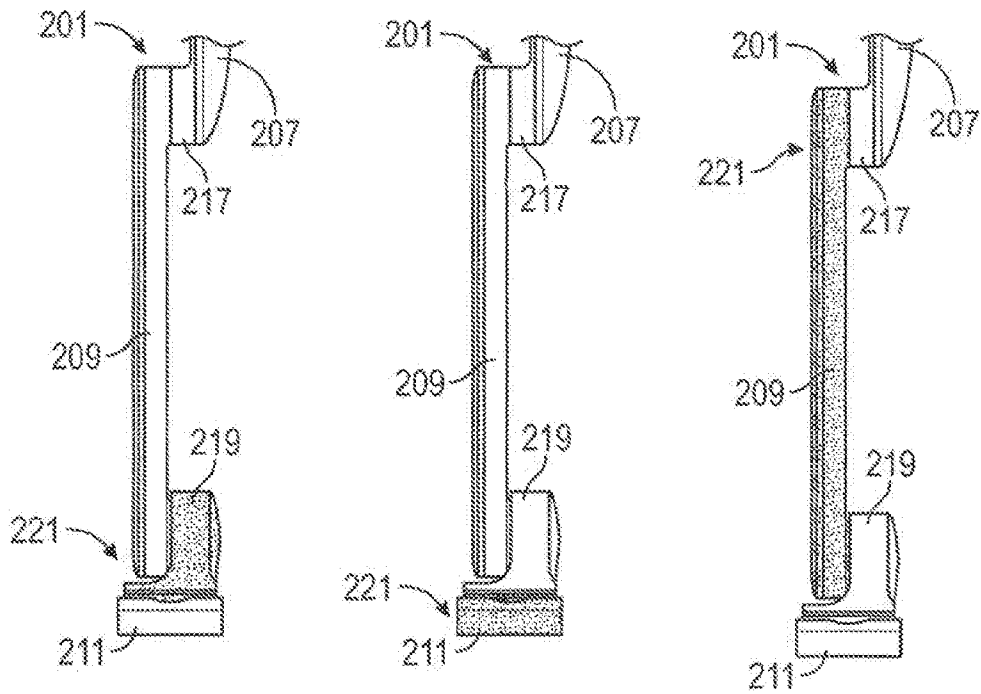
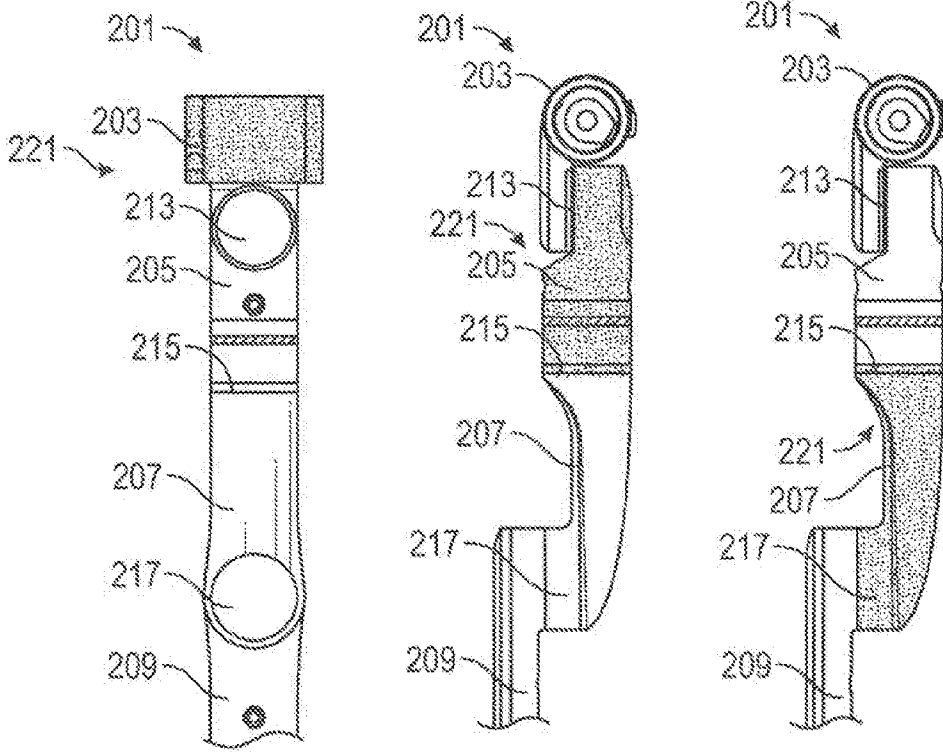

FIG. 20



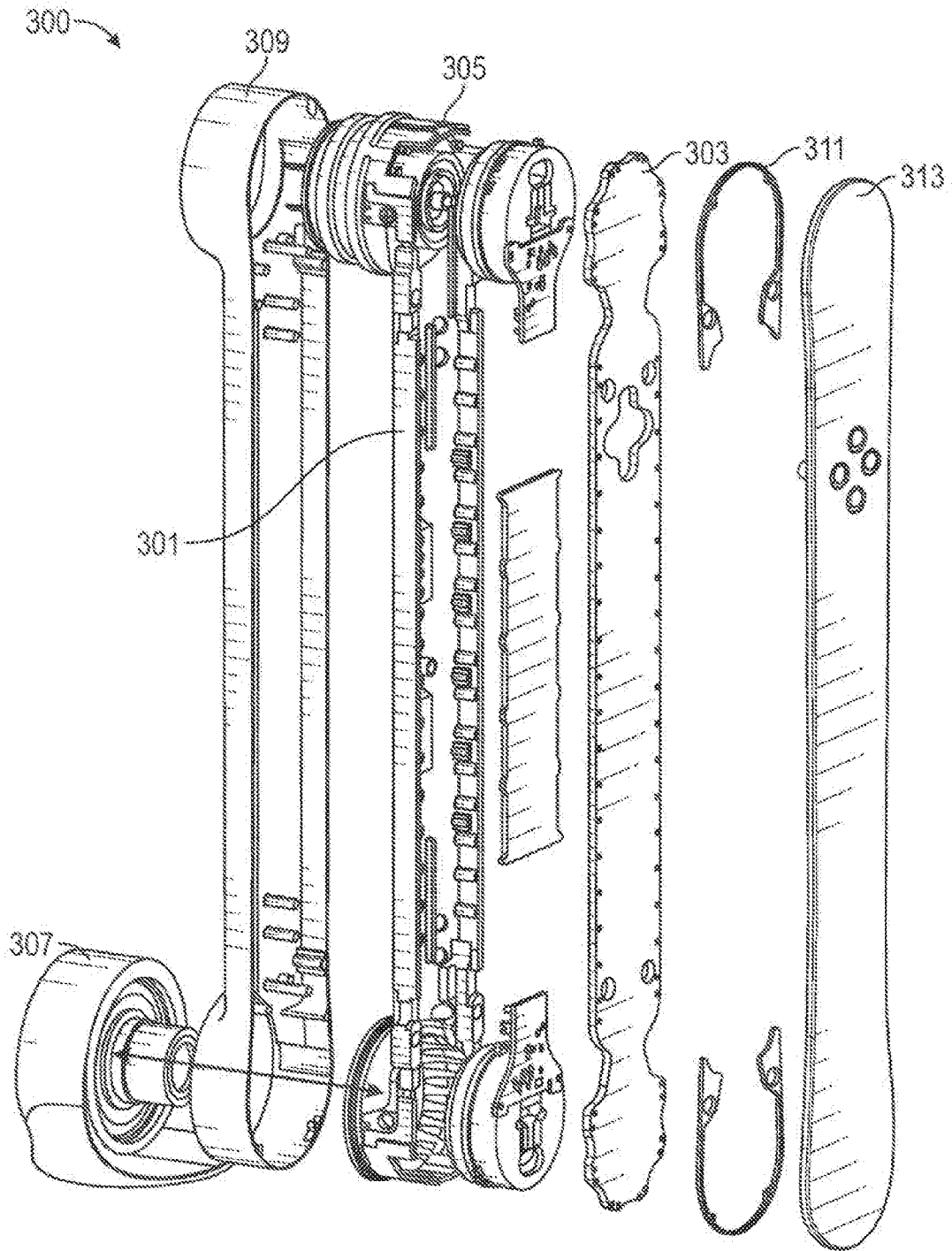

FIG. 22

321 →

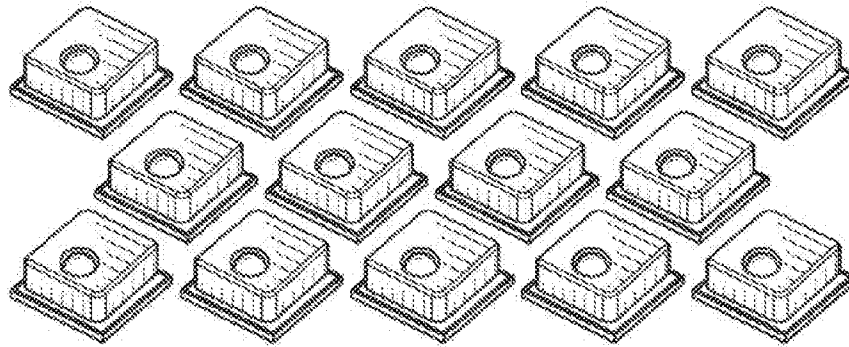

FIG. 23

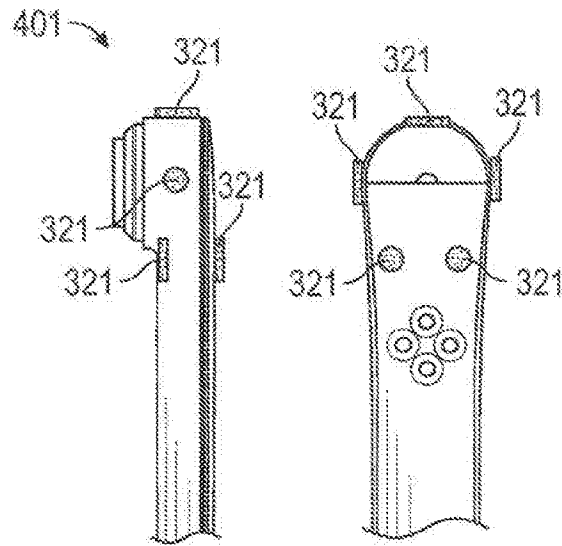

FIG. 24A

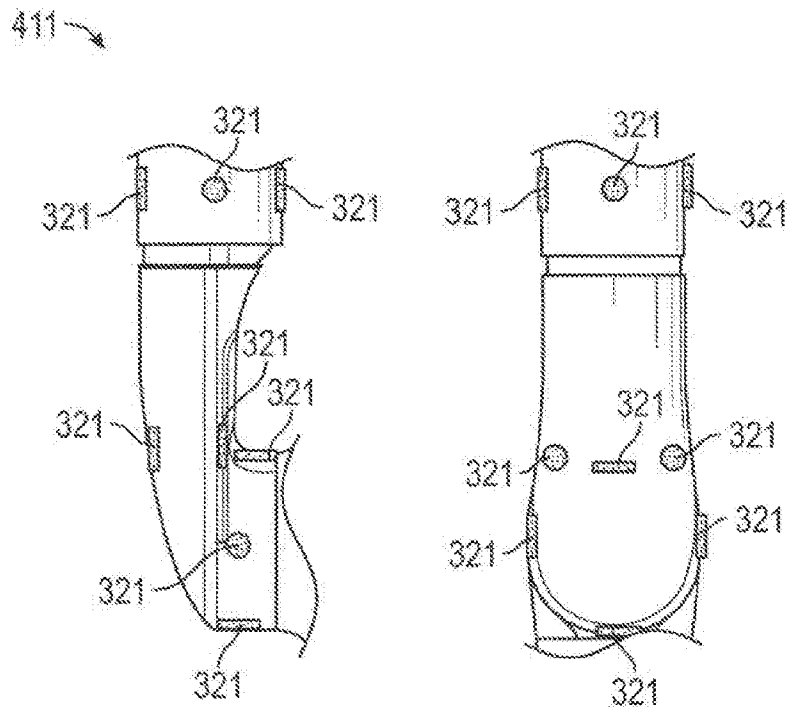

FIG. 24B

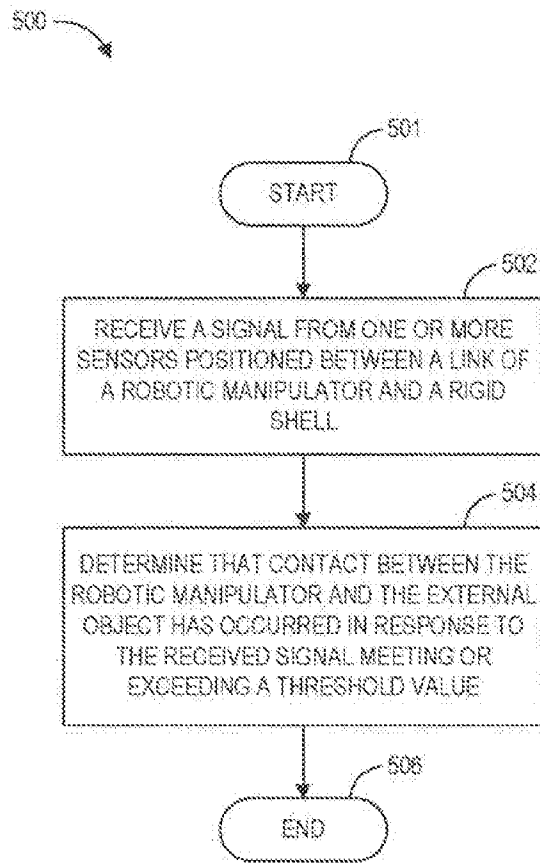

FIG. 25

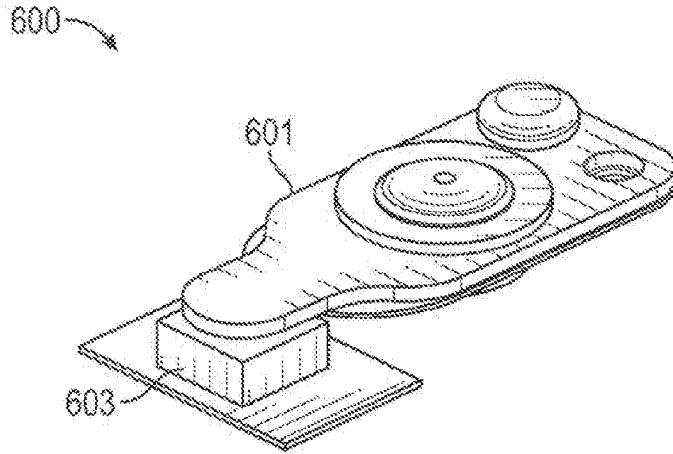

FIG. 26

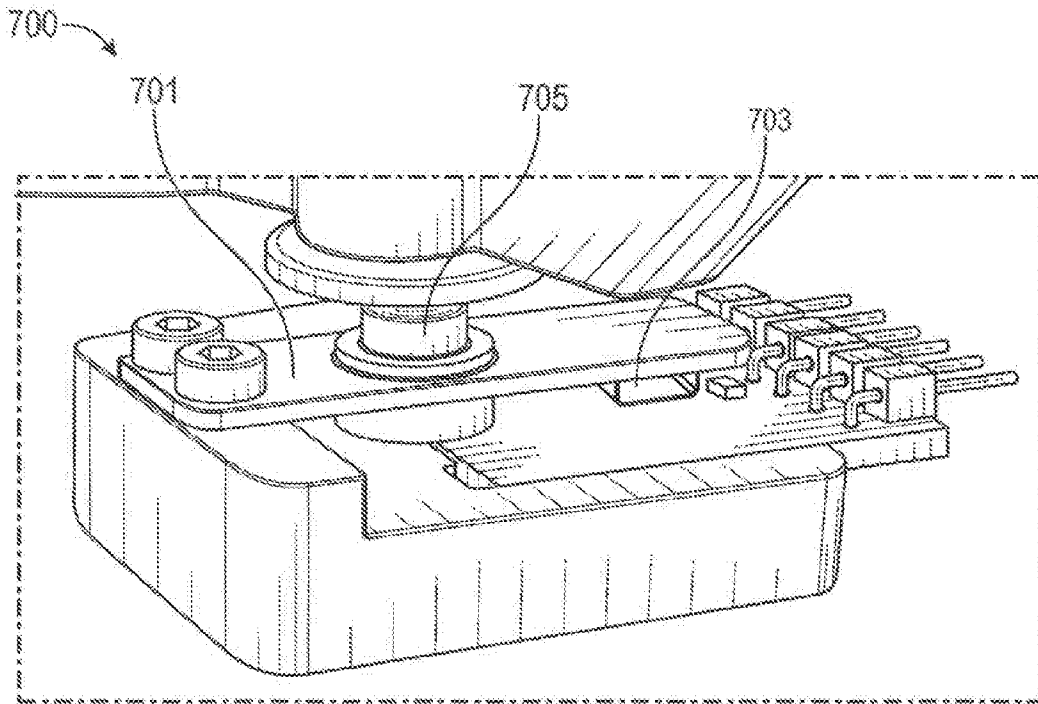

FIG. 27

800

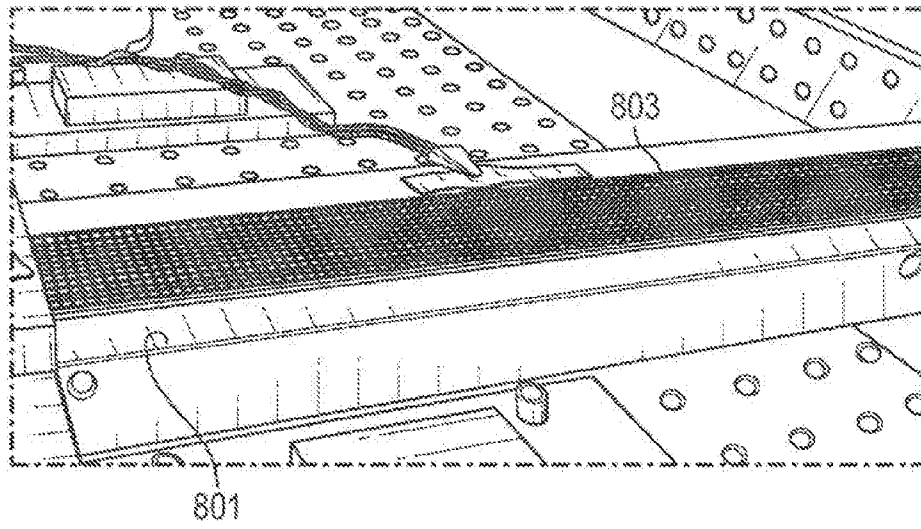

FIG. 28

INTERNATIONAL SEARCH REPORT

International application No.

PCT/IB2021/055496

A. CLASSIFICATION OF SUBJECT MATTER

A61B 34/30(2016.01)i; A61B 34/20(2016.01)i; A61B 34/00(2016.01)i; A61B 90/00(2016.01)i; B25J 9/16(2006.01)i

According to International Patent Classification (IPC) or to both national classification and IPC

B. FIELDS SEARCHED

Minimum documentation searched (classification system followed by classification symbols)

A61B 34/30(2016.01); A61B 17/16(2006.01); A61B 19/00(2006.01); B25J 13/08(2006.01); B25J 3/04(2006.01); B25J 9/10(2006.01); B25J 9/16(2006.01); G01L 5/22(2006.01)

Documentation searched other than minimum documentation to the extent that such documents are included in the fields searched

Korean utility models and applications for utility models
Japanese utility models and applications for utility models

Electronic data base consulted during the international search (name of data base and, where practicable, search terms used)

eKOMPASS(KIPO internal) & Keywords: robotic, manipulator, link, shell, contact, sensor, beam flexure

C. DOCUMENTS CONSIDERED TO BE RELEVANT

Category*	Citation of document, with indication, where appropriate, of the relevant passages	Relevant to claim No.
A	WO 2020-102776 A1 (INTUITIVE SURGICAL OPERATIONS, INC.) 22 May 2020 (2020-05-22) paragraphs [0052]-[0074]; claims 8-19; figures 5C-12	1-21
A	US 2020-0039086 A1 (AURIS HEALTH, INC.) 06 February 2020 (2020-02-06) paragraphs [0097]-[0102]; claims 30-41; figures 16-22	1-21
A	US 2018-0161115 A1 (BOARD OF REGENTS OF THE UNIVERSITY OF NEBRASKA) 14 June 2018 (2018-06-14) whole document	1-21
A	WO 2019-074669 A1 (AURIS HEALTH, INC.) 18 April 2019 (2019-04-18) whole document	1-21
A	KR 10-2015-0039801 A (STRYKER CORPORATION) 13 April 2015 (2015-04-13) whole document	1-21

 Further documents are listed in the continuation of Box C. See patent family annex.

* Special categories of cited documents:

“A” document defining the general state of the art which is not considered to be of particular relevance

“D” document cited by the applicant in the international application

“E” earlier application or patent but published on or after the international filing date

“L” document which may throw doubts on priority claim(s) or which is cited to establish the publication date of another citation or other special reason (as specified)

“O” document referring to an oral disclosure, use, exhibition or other means

“P” document published prior to the international filing date but later than the priority date claimed

“T” later document published after the international filing date or priority date and not in conflict with the application but cited to understand the principle or theory underlying the invention

“X” document of particular relevance; the claimed invention cannot be considered novel or cannot be considered to involve an inventive step when the document is taken alone

“Y” document of particular relevance; the claimed invention cannot be considered to involve an inventive step when the document is combined with one or more other such documents, such combination being obvious to a person skilled in the art

“&” document member of the same patent family

Date of the actual completion of the international search

27 September 2021

Date of mailing of the international search report

27 September 2021

Name and mailing address of the ISA/KR

Korean Intellectual Property Office
189 Cheongsa-ro, Seo-gu, Daejeon
35208, Republic of Korea

Facsimile No. +82-42-481-8578

Authorized officer

Jung, Da Won

Telephone No. +82-42-481-5373

INTERNATIONAL SEARCH REPORT

International application No.

PCT/IB2021/055496

C. DOCUMENTS CONSIDERED TO BE RELEVANT

Category*	Citation of document, with indication, where appropriate, of the relevant passages	Relevant to claim No.
A	WO 2009-123891 A1 (INTUITIVE SURGICAL, INC.) 08 October 2009 (2009-10-08) whole document	1-21

INTERNATIONAL SEARCH REPORT
Information on patent family members

International application No.

PCT/IB2021/055496

Patent document cited in search report			Publication date (day/month/year)	Patent family member(s)			Publication date (day/month/year)
WO	2020-102776	A1	22 May 2020	CN	113015498	A	22 June 2021
				WO	2020-102776	A8	22 May 2020
US	2020-0039086	A1	06 February 2020	AU	2018-347473	A1	23 April 2020
				CN	111328306	A	23 June 2020
				EP	3676060	A1	08 July 2020
				EP	3676060	A4	16 June 2021
				JP	2020-536755	A	17 December 2020
				KR	10-2020-0071745	A	19 June 2020
				US	10016900	B1	10 July 2018
				US	10434660	B2	08 October 2019
				US	2019-0105785	A1	11 April 2019
				WO	2019-074670	A1	18 April 2019
US	2018-0161115	A1	14 June 2018	CA	2906672	A1	25 September 2014
				US	10743949	B2	18 August 2020
				US	2014-0371762	A1	18 December 2014
				US	2020-0330172	A1	22 October 2020
				US	9888966	B2	13 February 2018
				WO	2014-152418	A1	25 September 2014
WO	2019-074669	A1	18 April 2019	AU	2018-347472	A1	23 April 2020
				CN	111386450	A	07 July 2020
				EP	3676587	A1	08 July 2020
				EP	3676587	A4	16 June 2021
				JP	2020-536754	A	17 December 2020
				KR	10-2020-0071744	A	19 June 2020
				US	10145747	B1	04 December 2018
				US	10539478	B2	21 January 2020
				US	2019-0107454	A1	11 April 2019
				US	2020-0217733	A1	09 July 2020
KR	10-2015-0039801	A	13 April 2015	AU	2013-296278	A1	12 February 2015
				AU	2013-296278	B2	14 June 2018
				AU	2014-233900	A1	08 October 2015
				AU	2014-233900	B2	08 March 2018
				AU	2018-202741	A1	10 May 2018
				AU	2018-202741	B2	14 November 2019
				AU	2018-220167	A1	13 September 2018
				AU	2018-220167	B2	12 September 2019
				AU	2018-220167	B9	05 December 2019
				AU	2019-275554	A1	02 January 2020
				AU	2019-275554	B2	26 November 2020
				AU	2021-201169	A1	11 March 2021
				CA	2879414	A1	06 February 2014
				CA	2906520	A1	25 September 2014
				CN	103620523	A	05 March 2014
				CN	103620523	B	31 May 2017
				CN	104736092	A	24 June 2015
				CN	104736092	B	21 July 2017
				CN	105392438	A	09 March 2016
				CN	105392438	B	01 May 2018
				CN	107198567	A	26 September 2017

INTERNATIONAL SEARCH REPORT
Information on patent family members

International application No.

PCT/IB2021/055496

Patent document cited in search report	Publication date (day/month/year)	Patent family member(s)	Publication date (day/month/year)
		CN 107198567 B	09 February 2021
		CN 108451643 A	28 August 2018
		CN 108451643 B	26 February 2021
		CN 112932672 A	11 June 2021
		EP 2659338 A1	06 November 2013
		EP 2659338 B1	21 November 2018
		EP 2879608 A2	10 June 2015
		EP 2879608 B1	18 March 2020
		EP 2967588 A2	20 January 2016
		EP 2967588 B1	21 October 2020
		EP 3344178 A1	11 July 2018
		EP 3620121 A1	11 March 2020
		EP 3756610 A1	30 December 2020
		KR 10-1902033 B1	27 September 2018
		KR 10-1943287 B1	28 January 2019
		KR 10-2014-0024846 A	03 March 2014
		KR 10-2015-0127129 A	16 November 2015
		KR 10-2018-0108852 A	04 October 2018
		KR 10-2021-0035922 A	01 April 2021
		KR 10-2021-0062719 A	31 May 2021
		KR 10-2257060 B1	28 May 2021
		US 10314661 B2	11 June 2019
		US 10350017 B2	16 July 2019
		US 10420619 B2	24 September 2019
		US 10426560 B2	01 October 2019
		US 10463440 B2	05 November 2019
		US 11045958 B2	29 June 2021
		US 2012-0176306 A1	12 July 2012
		US 2014-0039517 A1	06 February 2014
		US 2014-0039681 A1	06 February 2014
		US 2014-0222207 A1	07 August 2014
		US 2015-0265358 A1	24 September 2015
		US 2015-0289941 A1	15 October 2015
		US 2015-0366629 A1	24 December 2015
		US 2015-0374446 A1	31 December 2015
		US 2016-0089211 A1	31 March 2016
		US 2017-0000577 A1	05 January 2017
		US 2017-0128147 A1	11 May 2017
		US 2017-0172680 A1	22 June 2017
		US 2017-0177191 A1	22 June 2017
		US 2017-0245955 A1	31 August 2017
		US 2018-0071026 A1	15 March 2018
		US 2019-0192249 A1	27 June 2019
		US 2019-0269476 A1	05 September 2019
		US 2020-0022768 A1	23 January 2020
		US 2020-0030046 A1	30 January 2020
		US 9119655 B2	01 September 2015
		US 9226796 B2	05 January 2016
		US 9480534 B2	01 November 2016
		US 9566122 B2	14 February 2017

INTERNATIONAL SEARCH REPORT
Information on patent family members

International application No.

PCT/IB2021/055496

Patent document cited in search report	Publication date (day/month/year)	Patent family member(s)	Publication date (day/month/year)
		US 9566125 B2	14 February 2017
		US 9588583 B2	07 March 2017
		US 9681920 B2	20 June 2017
		US 9795445 B2	24 October 2017
		US 9820818 B2	21 November 2017
		US 9921712 B2	20 March 2018
		WO 2012-092201 A1	05 July 2012
		WO 2014-022786 A2	06 February 2014
		WO 2014-022786 A3	01 May 2014
		WO 2014-151550 A2	25 September 2014
		WO 2014-151550 A3	27 November 2014
		WO 2017-040821 A1	09 March 2017
WO 2009-123891 A1	08 October 2009	EP 2280662 A1	09 February 2011
		EP 2280662 B1	03 May 2017
		JP 2011-517419 A	09 June 2011
		JP 5575743 B2	20 August 2014
		KR 10-1615539 B1	26 April 2016
		KR 10-2011-0005829 A	19 January 2011
		US 2009-0248038 A1	01 October 2009
		US 9895813 B2	20 February 2018