

United States Patent

Gluckin et al.

[15] 3,653,075

[45] Apr. 4, 1972

[54] **STRETCHABLE STRAP OR THE LIKE**

[72] Inventors: **Gerald W. Gluckin**, 180 Madison Avenue, New York, N.Y. 10016; **Ronald J. Boser**, 21 Bolan Drive, Huntington Station, N.Y. 11746

[22] Filed: **Sept. 24, 1970**

[21] Appl. No.: **74,954**

[52] U.S. Cl. 2/338, 128/510, 139/387
[51] Int. Cl. A41f 15/00, A41f 3/02, A41f 1/00
[58] Field of Search 128/510-513, 483, 128/498; 2/323, 336, 310, 338, 236

[56] **References Cited**

UNITED STATES PATENTS

1,687,592 10/1928 Rothstein.....2/323

222,434 12/1879 Aarons2/338
2,059,103 10/1936 Hardie et al.2/338 X
1,880,908 10/1932 Duffy2/338 X
2,615,172 10/1952 Donegan.....2/338 X

Primary Examiner—Jordan Franklin
Assistant Examiner—Geo. V. Larkin
Attorney—Bauer & Amer

[57] **ABSTRACT**

An elongated composite construction serving as a strap or belt having an inner core consisting of an interconnected long strip of flannel or other non-stretchable material and a short elastic strip such that the construction has stretch confined to the elastic. Completing the construction is a tubular cover for the core which, although of moderate stretchability, nevertheless provides stretch which is compatible with that of the elastic strip because of its considerably greater length.

2 Claims, 6 Drawing Figures

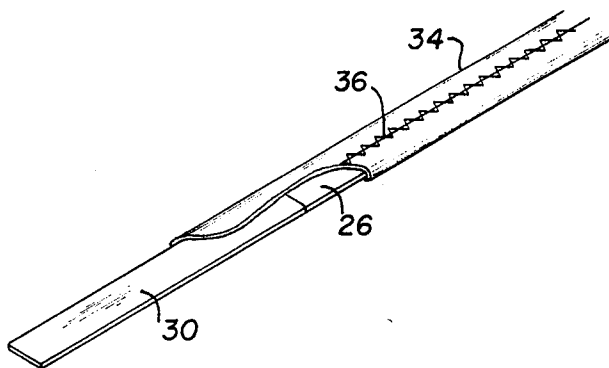

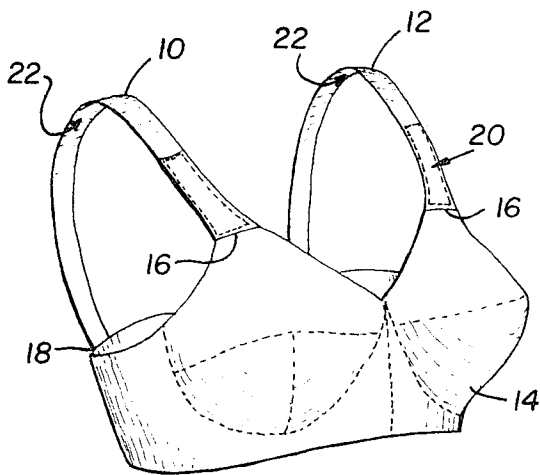

FIG. 1

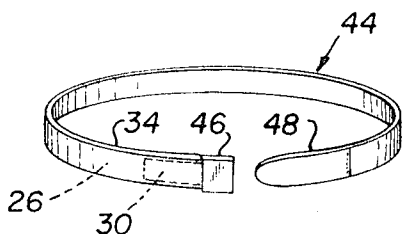

FIG. 2

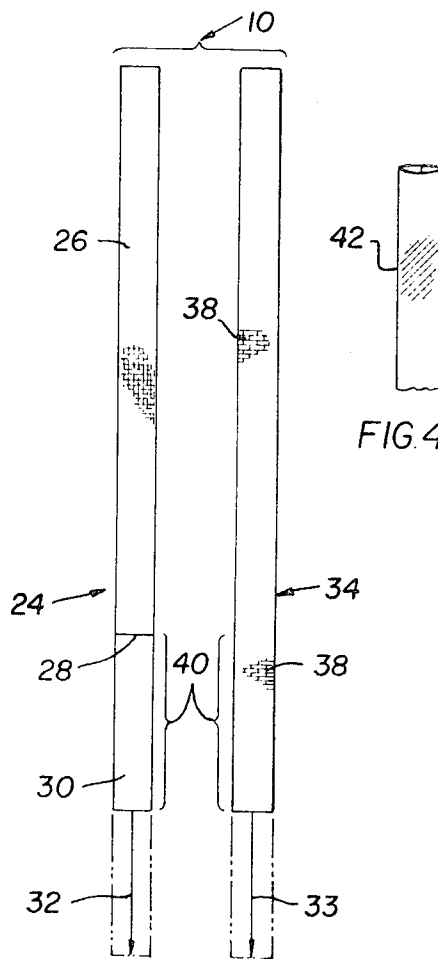

FIG. 3a FIG. 3b

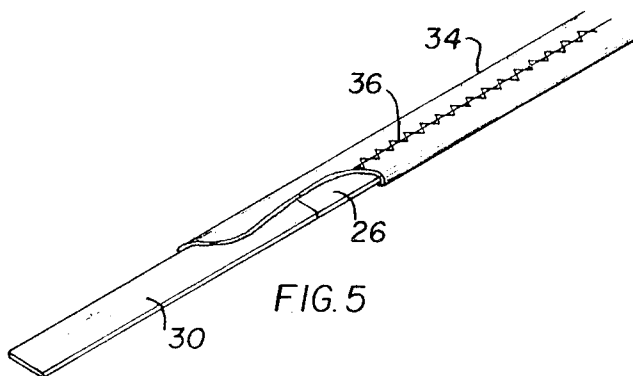

FIG. 5

INVENTOR.
GERALD W. GLUCKIN
RONALD J. BOSER
BY

Bauer & Amer
ATTORNEYS

STRETCHABLE STRAP OR THE LIKE

The present invention relates generally to stretch straps, belts or the like, and more particularly to improvements in the construction of this type product.

Stretch shoulder straps are currently in wide use for brassieres or the like since they provide the requisite support while properly allowing for body movements of the wearer. The stretch thereof is achieved by the use of elastic as the entire body of the strap or, in some instances, as a major length portion thereof. These known straps, however, are not entirely satisfactory. Straps fabricated entirely or wholly of elastic have a tendency to stretch or extend too readily, to provide more stretch than is necessary, and also are uncomfortable because of the rubbing and pinching which results from the stretching and contraction thereof. Also, the exposed elastic does not have a desirable commercial appearance.

Broadly, it is an object of the present invention to provide an improved stretchable strap or the like overcoming the foregoing and other shortcomings of the prior art. Specifically, it is an object to provide a construction having a stretchable core in which stretch is advantageously confined to a small elastic section which, in turn, can be favorably located as to minimize rubbing and pinching discomforts, and which has other noteworthy aspects as will be more particularly discussed subsequently herein.

A stretch strap or belt demonstrating objects and advantages of the present invention includes inner and outer materials which have differing stretch capacities per unit length but which nevertheless have the same compatible overall stretch or extensibilities because of the selected differing lengths of each that are used.

The above brief description, as well as further objects, features and advantages of the present invention, will be more fully appreciated by reference to the following detailed description of presently preferred, but nonetheless illustrative embodiments in accordance with the present invention, when taken in conjunction with the accompanying drawings, wherein:

FIG. 1 is a perspective view of a first embodiment of the stretchable member hereof serving as shoulder straps for a brassiere;

FIG. 2 is similarly a perspective view, but illustrating a second embodiment of the stretchable member hereof serving as a belt;

FIG. 3a is a plan view of the core used in the construction of the strap of FIG. 1 and of the belt of FIG. 2, and further illustrating the extensibility thereof;

FIG. 3b is a view similar to FIG. 3a, but illustrating a moderately stretchable tubular covering for the core, and also illustrating the extensibility thereof which is compatible with that of the core;

FIG. 4 is a partial plan view of another embodiment of the outer tubular member; and

FIG. 5 is a perspective view illustrating further structural details of the stretchable strap or the like.

Reference is now made to the drawings, and in particular to FIG. 1 wherein there is shown a cooperating pair of stretchable straps 10 and 12, each demonstrating objects and advantages of the present invention, attached to and serving as shoulder straps for a brassiere 14. Since the construction of each strap 10 and 12 is identical, the description thereof with specific reference to strap 10 will suffice for present purposes.

As applied to the aforesaid end use, the straps 10 and 12 are each attached, as at 16 and 18, to the brassiere 14 so as to have an operative supporting position looped over the shoulders of the wearer. Additionally, each strap, as will be more specifically disclosed herein, has a sufficient degree of extensibility lengthwise thereof to allow for body movements of the wearer. At the same time, both the straps 10 and 12 are not unduly extensible, as would be the case if they were entirely fabricated of an elastomeric or elastic material, and thus they provide the requisite support for maintaining the brassiere 14 in its proper position on the wearer. A further advantageous

feature of the straps 10 and 12 is that each provides extensibility in a localized area which, in the illustrated embodiment, is in the front areas 20. It has been found that in localizing the stretch and contraction of the straps to the localized areas 20, this contributes to comfort in the wearing of the straps since these areas are not in intimate contact with the skin of the wearer as are, for example, the areas 22 on the underside of the straps. Thus there is no pinching or rubbing of the wearer's skin during contraction or expansion in the areas 20. Further, the straps 10 and 12 have the optimum desirable commercial appearance of non-stretchable straps in that the elastic portion thereof, which must be included to provide extensibility, is not readily discernible.

Reference is now made to FIGS. 3a and 3b which best illustrate the structural details of the strap 10. Specifically, strap 10 is constructed of two major parts. One part is an inner core 24 which, in turn, consists of a comparatively long, inextensible or non-stretchable fabric strip 26 which is appropriately connected, as at 28, to a smaller elastic or elastomeric strip 30. An appropriate material for the non-stretchable strip 26 is flannel and, as demonstrated in FIG. 3a, the total extensibility 32 of the core 24 is attributable to the stretch capacity of the elastic strip 30. In this way, the stretchability of the strap 10 is confined to stretching and contraction of the elastic strip 30 which will be understood to be coextensive with the previously noted area 20.

The second part of the strap 10 consists of an outer tubular member 34, such as is illustrated in FIG. 3b. In the assembly of the strap 10, tube 34 is disposed in covering relation about the core 24 and the two parts are then united lengthwise, as by a seam 36 as illustrated in FIG. 5. More particularly, seam 36 may consist of zig-zag stitching or other loosely formed stitches which will not restrict the stretch of the outer tube 34.

Tube 34 in a preferred embodiment has a tricot construction 38 throughout its length which, as generally understood, is a construction which has an inherent moderate degree of extensibility. Thus, cooperative lengths 40 of the tube 34 and of the elastic 30 do not have the same degree of stretch; rather, the elastic 30 has a considerably greater stretch capacity than the tube 34. However, since the tube 34 is considerably longer than the elastic strip 30, the overall extensibility 33 of the tube 34 is of an amount which is approximately equal to the previously noted stretch 32. Thus, the stretch of the tube 34 when it occupies its operative covering position over the core 24 is compatible with the stretch 32 of the elastic strip 30.

In lieu of a tricot construction for the tube 34, use can be made of a woven construction 42, as illustrated in FIG. 4, provided only that this construction is oriented on the bias so as to permit bias stretch in the lengthwise direction of the tube.

The foregoing construction and functioning of the various parts of the strap 10 can also be utilized to advantage when embodied in a belt 44, as illustrated in FIG. 2. When adapted to this end use, the belt 44 is provided at its opposite ends with a cooperating connecting means, such as a buckle 46 and leather or similar strap 48. The body of the belt 44 will be understood to have the same construction as the strap 10, namely a comparatively small elastic strip 30, a comparatively longer inner non-stretchable strip 26, and a moderately stretchable outer tubular covering 34 which is coextensive with the length portions of both the strips 26 and 30.

From the foregoing, it should be readily appreciated that there has been described herein a strap, belt or the like which has a noteworthy stretch capacity but wherein the stretch is confined to a localized area coextensive with a hidden small length of elastic material.

A latitude of modification, change and substitution is intended in the foregoing disclosure, and in some instances some features of the invention will be employed without a corresponding use of other features. Accordingly, it is appropriate that the appended claims be construed broadly and in a manner consistent with the spirit and scope of the invention herein.

What is claimed is:

1. A stretchable shoulder strap for a brassiere or the like comprising an elongated core of a predetermined longitudinal extent fabricated of an interconnected inelastic strip and an elastic strip, said inelastic strip being sized to substantially comprise said longitudinal extent of said core, said elastic strip constituting the remainder of the length of said core having a comparatively high degree of stretch so as to provide extensibility to said shoulder strap, an outer tubular member in covering relation about and along the entire longitudinal extent of said core having only a moderate degree of stretch relative to that of said elastic strip but throughout said entire lon-

gitudinal extent thereof, and a longitudinally oriented seam of zig-zag stitching connecting said core and said outer tubular member, whereby said greater longitudinal extent of said tubular member provides extensibility to said member which is substantially the same as that of said core.

2. A stretchable strap or the like as defined in claim 1 wherein said outer tubular member is a woven fabric so arranged as to partake of bias stretch in the longitudinal direction of said stretchable strap or the like.

* * * * *

15

20

25

30

35

40

45

50

55

60

65

70

75