

(19) World Intellectual Property Organization
International Bureau



(43) International Publication Date
17 December 2009 (17.12.2009)

(10) International Publication Number
WO 2009/149927 A1

(51) International Patent Classification:
A61F 2/84 (2006.01)

(21) International Application Number:
PCT/EP2009/004199

(22) International Filing Date:
10 June 2009 (10.06.2009)

(25) Filing Language: English

(26) Publication Language: English

(30) Priority Data:
0810749.2 11 June 2008 (11.06.2008) GB
61/060,568 11 June 2008 (11.06.2008) US

(71) Applicant (for all designated States except US): AN-
GIOMED GMBH & CO. MEDIZINTECHNIK KG
[DE/DE]; Wachhausstrasse 6, 76227 Karlsruhe (DE).

(72) Inventor; and

(75) Inventor/Applicant (for US only): DORN, Jürgen [DE/
DE]; Küstriner Weg 2, 68809 Neulussheim (DE).

(74) Agent: MARSCH, Roy; Hoffmann . Eitle, Arabellas-
trasse 4, 81925 München (DE).

(81) Designated States (unless otherwise indicated, for every
kind of national protection available): AE, AG, AL, AM,

AO, AT, AU, AZ, BA, BB, BG, BH, BR, BW, BY, BZ,
CA, CH, CL, CN, CO, CR, CU, CZ, DE, DK, DM, DO,
DZ, EC, EE, EG, ES, FI, GB, GD, GE, GH, GM, GT,
HN, HR, HU, ID, IL, IN, IS, JP, KE, KG, KM, KN, KP,
KR, KZ, LA, LC, LK, LR, LS, LT, LU, LY, MA, MD,
ME, MG, MK, MN, MW, MX, MY, MZ, NA, NG, NI,
NO, NZ, OM, PE, PG, PH, PL, PT, RO, RS, RU, SC, SD,
SE, SG, SK, SL, SM, ST, SV, SY, TJ, TM, TN, TR, TT,
TZ, UA, UG, US, UZ, VC, VN, ZA, ZM, ZW.

(84) Designated States (unless otherwise indicated, for every
kind of regional protection available): ARIPO (BW, GH,
GM, KE, LS, MW, MZ, NA, SD, SL, SZ, TZ, UG, ZM,
ZW), Eurasian (AM, AZ, BY, KG, KZ, MD, RU, TJ,
TM), European (AT, BE, BG, CH, CY, CZ, DE, DK, EE,
ES, FI, FR, GB, GR, HR, HU, IE, IS, IT, LT, LU, LV,
MC, MK, MT, NL, NO, PL, PT, RO, SE, SI, SK, TR),
OAPI (BF, BJ, CF, CG, CI, CM, GA, GN, GQ, GW, ML,
MR, NE, SN, TD, TG).

Published:

- with international search report (Art. 21(3))
- before the expiration of the time limit for amending the
claims and to be republished in the event of receipt of
amendments (Rule 48.2(h))

(54) Title: CATHETER DELIVERY DEVICE

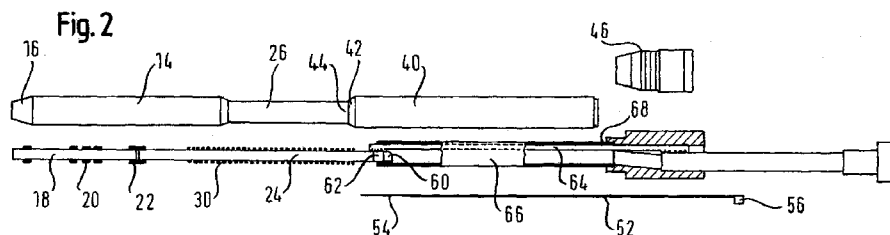

(57) Abstract: A catheter delivery device for a self-expanding stent including a distal catheter component, a distal sheath disposed over the stent, a proximal catheter shaft defining a tube; a proximal sheath connected to the distal sheath defining a lumen containing the catheter shaft, an open distal end suitable to receive the proximal end of the distal catheter component side-by-side with the distal end of the catheter shaft and; a casing tube surrounding the catheter shaft having a distal end telescopically receiving the proximal end of the distal sheath.



WO 2009/149927 A1

Catheter delivery device

Technical field

This invention relates to a catheter which is a delivery device for a self-expanding stent to be delivered to a stenting location in the body trans-luminally. The device is of the "pull wire" type and is designed for delivery of covered stents of significant length, that represent a tougher delivery task than a short bare stent. The device described below is of the "over the wire" category. However, the present invention can also be applied to "rapid exchange" catheter delivery devices. Guidewire diameters of 18 or 35 "thou" are conventional, and contemplated for use with this invention. Covered stents with deployed diameters in a range of from 6 mm to 18 mm are contemplated.

Background art

The present applicant has progressively developed delivery devices for covered stents. One example is to be found in WO2005/053574. The present invention carries such architecture forward into the technical field of covered stents that are lengthier (maybe up to 120 mm, or even beyond) and so put greater demands on the strength of the delivery system during deployment of the stent, when a sheath surrounding the stent has to be pulled proximally, relative to the stent, to release the stent into the bodily lumen to be stented, progressively, starting at the distal end of covered stent. Readers will appreciate that it is characteristic of such catheter delivery devices that one of two end-to-end components is in endwise tension (the components responsible for pulling the sheath proximally) while the other of the two end-to-end components (the one that prevents the stent from being drawn proximally with the

proximally moving sheath) is in end-to-end compression during progressive deployment of the stent. In general, designers of catheter delivery devices for self-expanding stents try to keep the passing diameter of the catheter to a minimum, which self-evidently conflicts with the design imperative that the end-to-end component in compression does not buckle or concertina, or otherwise lose its length integrity, during stent deployment. The present invention sacrifices ultimate narrowness of passing diameter to the objective of enhanced performance in delivering relatively lengthy covered stents, for which endwise stresses in the catheter delivery device, during deployment of the stent, are likely to be higher than for shorter stents that are bare rather than covered.

Catheter delivery devices that exhibit a "pull wire" are attractive for tasks where the end-to-end stresses are relatively large, because a wire is well able to sustain endwise tension, but not so well adapted to sustain an endwise compressive stress. Better for that task is a tube. Thus, in a coaxial system, one with the tube carrying the compressive stress, and the wire within it carrying the tensile stress, will likely perform better than a system arranged the other way around. However, at the distal end of the system, where the stent is located, it is the outside sheath that is in tension, and the inside catheter element, that stops the stent moving proximally, that is in compression. Thus, somewhere between the proximal and distal end of the catheter delivery system of a pull wire architecture, there needs to be an inversion, to transfer the tensile stress from the radially inner pull wire to the radially outer sheath surrounding the stent. Clearly, any length interval between the transfer zone and the distal end of the stent, in which a relatively small diameter component of the catheter system is required to carry the endwise compressive stress during stent deployment, needs to be strong enough to retain its lengthwise integrity during such

stent deployment. Self-evidently, the length of that portion should be reduced, to the extent possible.

A further problem with transfer zones in pull wire systems is to minimise any propensity for the catheter system to buckle at any particular point along its length. Evidently, there is a challenge to incorporate a transfer zone somewhere along the length of the catheter shaft, while at the same time avoiding any points long the length of the catheter where there is an increased risk of buckling.

Summary of the invention

Catheter delivery devices in accordance with the present invention can feature novelty in the architecture of the part of the system that withdraws proximally to release the stent. Alternatively, they can exhibit novelty in that part of the system that retains the stent against proximal withdrawal during stent deployment. Preferably the novelty is in both of these component parts of the system, working synergistically together. Each of the contributions to the architecture of the catheter delivery device constitutes an invention in its own right, but the combination of the improved architecture pull back component, with the improved architecture of the component that carries the end-to-end compression during stent deployment, can yield synergistic results that allow the deployment through narrow tortuous lumens, of remarkably lengthy covered stent prostheses.

According to a first aspect of the present invention there is provided a catheter delivery device in which a casing tube surrounds the catheter shaft and has a distal end that receives telescopically a proximal end of the distal sheath of the device, with a pull wire fixed to a proximal end zone of the distal sheath within the lumen of the casing tube.

Normally, the casing tube proximal end is fixed to a hub of an actuating device (otherwise called "hand unit"). Conveniently, the delivery device includes a retaining ring that retains the pull wire on the radially outside surface of a proximal end zone of the distal sheath, the ring embracing the radially outside surface of the distal sheath, near its proximal end. Usefully, the distal end zone of the pull wire is thinned and given the shape of part of a cylindrical surface with a radius that corresponds to that of the radially outer cylindrical surface of the distal sheath near its proximal end, whereby the thinned end zone of the pull wire can lie flush, or close to flush, with a radially outside surface of the distal sheath and, conveniently, clamped to that outside surface by the retaining ring, which is conveniently a swaged ring.

Readers skilled in the art will be able to envisage other ways of extending a sheath into a pull wire. For example, the material of the sheath could itself be continued proximally, to form the pull wire.

In one preferred embodiment, the distal sheath exhibits a diving tube proximal of the location of the stent. The inventor calls this component of the device a "diving" tube because it "dives" into the open distal end of the casing tube and slides proximally within the lumen of the casing tube, during deployment of the stent. The diving tube has an outside diameter slightly smaller than that of more distal portions of the distal portion of the distal sheath, that embrace the stent. Conveniently, the distal end of the diving tube is fixedly received inside the open proximal end of a distal portion of the distal sheath. At the distal end of the distal portion of the distal sheath an inwardly tapered atraumatic tip can be provided, for the catheter device as a whole. Normally, the pull wire will be attached to a zone of the diving tube relatively close to the proximal end of the diving tube, inside the lumen of the casing tube.

Conventionally, in stent delivery systems, an atraumatic tip is provided on an axial component that extends through the lumen of the stent, with the stent sheath terminating proximally of that atraumatic tip. Such arrangements are compatible with the present invention and can provide embodiments of it.

In another aspect of the present invention, the inner catheter component of the delivery device includes a proximal sheath that has a lumen that contains the catheter shaft of the delivery device. It has an open distal end that receives a proximal end of the distal catheter component, side-by-side with the distal end of the catheter shaft. The proximal sheath and the distal catheter component together provide a guidewire lumen that runs the full length of the delivery device, thereby to render the delivery system a member of the "over the wire" type. In one preferred embodiment, the distal end of the catheter tube carries, to one side of the tube axis, a transfer ring that embraces the proximal end of the distal catheter component. We call this ring a "transfer" ring because it marks the transfer of endwise compressive stress during deployment of the stent, between the outer coaxial component constituted by the catheter shaft tube, and the inner coaxial component at the distal end of the delivery device, inside the distal sheath that is pulled proximally to release the stent.

Readers will be able to envisage alternatives to a transfer ring. Depending on the materials of construction of the catheter tube and the distal catheter component, these two components could be joined, side by side, with techniques such as glueing, fusion welding, strapping together or brazing, as well as form-fitting and other ways of achieving a mechanical interference that resists axial shortening.

As mentioned above, the catheter system as a whole must resist any tendency to kink under endwise compression. Transition zones are particularly vulnerable to unwanted kinking. It may therefore be worthwhile to install at the side by side component transfer zone an extra splint or sleeve, to enhance resistance to kinking in this zone.

The conventional way to stop a stent from moving proximally during proximal withdrawal of the surrounding sheath in deployment of the stent, is to provide a form of "stop ring" that the proximal end of the stent butts up against, whenever the stent seeks to move proximally. Normally, such an arrangement imposes no undue compressive stresses on any part of the stent matrix. However, in a case where the stent might be vulnerable to excessive end-to-end compressive stress, a better arrangement is to give the stent cylinder a measure of support, against proximal movement, over a greater part of the length of the stent than just the proximal end surface of the stent cylinder. Since the catheter delivery device of the present invention is specifically adapted for use with lengthy covered stents, it is advantageous to continue the distal catheter component into a stent support tube that is located, in use, inside the lumen of the stent, and supports the stent around that lumen, against proximal withdrawal relative to the distal catheter component, during proximal withdrawal of the surrounding sheath. In one preferred embodiment, the stent support tube is provided with a plurality of annular cushions that mechanically interfere with the covered luminal surface of the stent radially outside the stent support tube.

The word "cushion" is to be interpreted liberally. For example, a simple spiral protruding radially, to press against the luminal surface of the prosthesis or implant, covered stent or bare stent, can serve the desired purpose. Other arrangements are already within the published patent

literature, and becoming more numerous as stent lengths continue to increase.

Applicant has previously developed delivery systems for self-expanding stents in which the distal sheath and stent are free to rotate coaxially, relative to the catheter shaft. While this is still possible to engineer, with the present invention, it is envisaged also to have the stent support tube fixed to the catheter shaft without freedom to rotate thereby fixing (via the stent) the outer sheath against rotation relative to the catheter shaft. With such rotation inhibited, there is no risk that the pull wire can wrap itself around the other catheter shaft component.

The distal catheter component, where it lies proximal of the proximal end of the stent, needs to have enough column strength to resist the compressive stress imposed on it when the stent is being released. A known way to improve the column strength of a catheter component is to wrap it with a helical wire. Accordingly, in one preferred embodiment of the present invention a compound catheter portion of the distal catheter component includes a helix of wire to stiffen the compound catheter portion when the compound catheter portion is in end-to-end compression.

Readers will be well aware of the importance of achieving a high enough resistance to compressive stress, and adequate column strength. Also in this area of design, the patent literature offers the reader a range of alternatives to a helical wire wrapping. Specifically, a tube of metal, for example stainless steel or PHYNOX (RTM) with a multitude of through wall slits transverse to its length direction, can combine high flexibility with high column strength. For a relevant disclosure, see WO2006/133960 and EP-A-1656963.

In one embodiment (not shown) the proximal end zone of the distal catheter component comprises a length portion that

exhibits a multitude of slits with their length direction transverse to the length of the distal catheter component. Such slits can increase the flexibility in bending of the distal catheter component, at least in its proximal end zone. Usefully, the slitted length portion is extended distally towards the location of the proximal end of the stent. The distal extension would normally be all the way to the proximal end of the stent but might be less than all the way, for example, if the distal catheter component exhibits a change of material, from metal to polymer, in a zone located proximally of the proximal end of the stent.

Conveniently, the delivery device includes a connection tube with a lumen that receives, in its distal end, the proximal end of the stent support tube and, in its proximal open end, the distal end of the compound catheter portion. Adhesive compositions can be used to build the combination of the distal catheter component. The annular cushions on the stent support tube can have other forms, indeed, any suitable form of "embossing" that is capable of resisting relative axial movement of the stent, proximally, relative to the distal catheter component.

It is suggested above that cushions within the lumen of the stent can take over completely from a "pusher" ring that abuts the proximal end of the stent. Nevertheless, a ring to abut the proximal end of the stent can also be provided here. In one embodiment, it assists the cushions. In another embodiment it is deliberately spaced away from the proximal end of the prosthesis, and abuts that proximal end only in the event that the cushions somehow fail to prevent all proximal movement of the prosthesis during its deployment.

Brief description of the drawings

For a better understanding of the present invention, and to show more clearly how the same may be carried into effect,

reference will now be made, by way of example, to the accompanying drawings, in which:

- Fig. 1 is a lengthwise diametral section of a distal end portion of a first embodiment of catheter delivery device in accordance with the present invention;
- Fig. 2 is a schematic lengthwise diametral section of the delivery device of Fig. 1, partly exploded to show individual components separately;
- Fig. 3 is a longitudinal diametral section, as in Figs. 1 and 2, but showing the device in its assembled form; and
- Fig. 4 is a longitudinal diametral section through the compound catheter portion.

Detailed description of the preferred embodiment

The illustrated delivery system 10 is for delivering a covered stent 12 that can be seen in Fig. 1 compressed inside a distal sheath 14 that has an atraumatic tapered distal tip 16. The stent being a self-expanding stent, it is pressing on the radially inner cylindrical surface of the outer sheath 14. Inside the radially compressed stent 12 is a stent support tube 18 that defines a guidewire lumen (not visible in Fig. 1) and carries on its outer cylindrical surface a plurality of annular cushions 20. For covered stents with a length of more than 100 mm we propose three such cushions near the proximal end of the stent, one at the distal end of the stent, and one part-way along the length of the stent. For shorter stents, the cushion part-way along the stent is likely not needed. The cushions are made of DYMAX material and each can be of a length along the axis of the stent that is in the area of 2 mm to 4 mm. Depending how the cushions are attached to the support tube 18, it may be beneficial to

provide at the distal end of the tube a safety element, namely some form of a stopper that will stop any annular cushion inadvertently sliding off the distal end of the support tube during deployment of the stent.

In Fig. 1, the stent support tube 18 has a proximal end that is received within a short connection tube 22, that also receives the distal end of a compound catheter portion 24 based on a tube of polyimide with braid reinforcement within its annular wall thickness, that is destined to carry a lengthwise compression stress when the distal sheath 14 is pulled proximally away from the stent 12 to release it from the delivery system. What pulls the distal sheath 14 from around the sheath is a proximal portion of the distal sheath which we call a "diving sheath" 26 that has an outside diameter marginally smaller than the inside diameter of the distal sheath 14 and a distal end that is received inside the lumen at the proximal end of the distal sheath 14, where it is fixed by an adhesive composition. The diving sheath 26 surrounds the compound catheter component, with clearance. We propose that it be of braided polyamide with a wall thickness of 100 μm . In the case of relatively large diameter prosthesis, deliverable with a relatively small diameter catheter shaft, it may be that the inside diameter of the distal sheath 14 is significantly bigger than the outside diameter of the distal end of the driving sheath. In such a case it may be useful to provide an intermediate spacer sleeve between the two components.

The compound catheter component in the lumen of the diving sheath has a polyimide shaft element 28 that defines a guidewire lumen and carries glued on its outer cylindrical surface a helical wind of fine wire 30 which serves to stiffen the tube 28 against bending, without too much loss of bending flexibility, especially when the tube 28 is under endwise compression.

Before leaving Fig. 1, we draw it to the attention of readers that the distal sheath 14, without the diving sheath 26, can serve as a pre-assembly during manufacture of the catheter delivery device, with the stent support tube 18 and stent 12 being inserted into the sheath 14 to constitute the sub-assembly. At a later stage in manufacture, the tube 28 of the compound catheter portion can be connected to the stent support tube 18, for example, by heat-shrinking the polyamide connection tube 22 around both the tube 18 and the stent support tube 18, using a PET shrink tube at around 200°C. After such shrinking, the PET tube is removed and discarded. Thereafter, the diving sheath 26 can be introduced into the distal sheath 14 with or without an intervening spacer sleeve, and fixed to it with adhesive.

Turning now to Fig. 2 of the drawings, we see components of the delivery device arranged in an "exploded" form, just enough to separate the components of the inner and outer coaxial members. Thus, the sub-assembly of distal sheath 14 and diving sheath 26 is shown displaced sideways from the stent support tube but coaxial with a casing tube 40 that has a distal end 42 that receives a proximal end 44 of the diving sheath 26. The proximal end of the casing tube 40 is fixed by adhesive to a strain-relieving hub 46 of a hand unit that will actuate the deployment of the stent from the delivery device. During deployment of the stent, the distal sheath 14 and diving sheath 26 move proximally, but the casing tube 40 does not, so that the proximal end of the diving sheath 26 slides proximally down the lumen of the casing tube 40, from the open distal end 42.

We briefly turn to Fig. 3 to complete the description of the proximal movement of the distal sheath. Fig. 3 shows a pair of retaining bands 50 that are swaged into rings around a proximal end zone of the diving sheath 26. These rings press onto the outer cylindrical surface of the diving sheath 26, the distal end of a pull wire 52 which has a flattened

portion 54 at its distal end that lies underneath the swaged bands 50, pressed against the surface of the diving sheath 26. Laser welding is used, to weld the pull wire to the retaining bands 50. It is tension in the pull wire 52, imposed from proximal of the proximal end 56 of the pull wire 52, that pulls the diving sheath, and hence the distal sheath 14, away from the stent 12.

Reverting to Fig. 2 of the drawings, we see again the stent support tube 18, connection tube 22 and compound catheter portion 24. We also see the proximal end 60 of the tube 28 of the compound catheter portion 24 being held within a transfer ring 62 that is swaged around the proximal end 60. That transfer ring is welded to a catheter shaft tube 64 of PHYNOX alloy that defines a lumen that channels the pull wire 52.

A proximal sheath 66 surrounds the catheter tube 64, nested, but with the catheter tube 64 away from the rotational axis of the proximal sheath 66. That leaves most of the cross-section of the lumen of the proximal sheath 66 free for flushing liquids and a guidewire. The guidewire lumen defined by the proximal sheath 66 continues into the lumen of the compound catheter portion and stent support tube. The proximal end 68 of the sheath 66 is set in the same hub 46 as carries the proximal end of the casing tube 40, so that there is no relative endwise movement between the casing tube 40 and the proximal sheath 66. Please note that the ratios of diameter to length in Figs. 2 and 3 of the drawings bears no relation to reality, in which the overall length of the device likely will be substantially more than a 100 cm whereas the passing diameter contemplated is less than 3 mm (7 French or 8 French). It appears from Fig. 2, for example, that the diving sheath 26 will abut the proximal sheath 66, at least when the stent is deployed. However, looking at Fig. 3, we can see a very substantial end-to-end gap between the diving sheath 26 and the distal end of the proximal sheath 66. The representation in Fig. 3 is misleading as to the

length of the proximal sheath 66. In practice, it occupies a very substantial portion of the total length of the system. The total length of the distal sheath 14, diving sheath 26 and compound catheter portion 24, proximally as far as the transfer ring 62, will be much less than 50% of the total length of the catheter system. In reality, and prior to deployment of the implant, the proximal end of the diving sheath 26 is a considerable distance away, distally, from the distal end of the proximal sheath 66, as shown in Fig. 3, but contrary to the impression given by the exploded diagram of Fig. 2.

For a more detailed description of the compound catheter portion, see the text below, that describes what is shown in Fig. 4 of the drawings.

In operation, the delivery device with its distal end zone looking like it is represented in Fig. 1 is introduced transluminally into the body, and advanced as is known per se, until the distal end is at the location in the body where stenting is desired. At that point, when the stent is to be deployed, the hand unit is actuated, to impose a tensile stress on the pull wire 52, from its proximal end 56. This tensile stress passes through to the distal sheath 14, which moves proximally, with sliding of the diving sheath 26 into the casing tube 40. The stent 12 would be inclined to be carried proximally with the outer sheath 14, except that it is prevented from so doing, by the interaction with the inner surfaces of the covered stent by the cushions 20 of the stent support tube 18. Any tendency of the stent support tube 18 to move proximally with the outer sheath 14 is resisted by compression stress that is generated all the way from the actuation unit along the catheter tube 64, through the transfer ring 62 and along the compound catheter portion 24, up to the end-to-end abutment with the stent support tube 18 inside the connection ring 22, and thence to the cushions 20 and the stent.

After successful deployment of the stent, retraction and removal of the delivery device is relatively straightforward. The cylindrically outside surfaces of the catheter system are generally smooth, and likely anyway to be coated with a lubricious coating. The atraumatic distal tip 16 of the system has stretched to pass proximally over the covered stent but is still residually inwardly tapered during withdrawal of the system. Inside the stent, there is no bulky tip structure that has to pass through the lumen of the stent, from beyond the distal end to proximally of the stent lumen. Instead, the only structure that has to slip proximally out of the stent lumen is that of the stent support tube 18, which represents a minimal tendency to snag on the inside of the stent.

Turning now to Fig. 4 of the drawings, we find the compound catheter portion 24 shown at a larger scale so that its constructional details can be seen more clearly. The portion 24 is based on a polyimide tube 28 that includes within its annular wall thickness a braid of flat wire. The annular wall thickness is 0.075 mm and the outer diameter is 1.16 mm. The inner diameter is 1.01 mm and the flat braiding wire has a rectangular cross-section of thickness 0.013 mm and width of 0.076 mm. The braid is based on SS304W steel material, braided at 100PPI (crossing points per inch). There are 16 wire bands altogether in the braid.

Turning now to the helical wind of multi-strand wire on the outer cylindrical surface of the polyimide tube 28, this is glued to the tube with cyanocrylate glue and, after wrapping, the outside diameter of the helical coil is 1.5 mm (to a tolerance of 0.02 mm). After mounting on the tube 28, the helical coil is ground to a final outside diameter of 1.4 mm. As is evident from drawing Fig. 4, the helical coil does not cover the entire axial length of the compound catheter component. Proximally, it stops short of the transfer ring

62. Distally, it stops 50 mm short of the distal end of the tube 28, well short of the connection tube 28 and, as can be seen in drawing Fig. 1, well short of the proximal end of the sheath 14 which lies radially outside the covered stent 12.

Variations in the construction of the delivery device shown in the drawings will be evident to those skilled in the art. Materials selection is part of the routine burden of the delivery system designer, as is choice of methods for reliably connecting individual components of the delivery system. A number of individual features of the stent delivery system are known in themselves, but there are multitudes of features routine to use in stent delivery devices that can be mixed and matched to achieve particular requirements of the delivery task to be performed. The number of design considerations to be taken into account is almost infinite. Thus, putting together a synergistic combination of individual components, that permits the delivery of longer covered stents than hitherto, with greater radial stenting force than hitherto, beyond the capability of any delivery system hitherto available, represents a valuable and important contribution to the art.

Industrial applicability

A catheter delivery device is disclosed, that has a specific architecture capable of delivering through tortuous bodily lumens with a narrow diameter a covered self-expanding stent with a greater length, and higher stenting force, than would hitherto have been possible.

Claims

1. A catheter delivery device for a self-expanding stent, with a distal catheter component and a distal sheath that releases the stent by moving proximally relative to the distal catheter component and the stent and which includes a proximal catheter shaft that exhibits a tube and a pull wire within the lumen of the tube, said pull wire being attached to the distal sheath whereby pulling the pull wire proximally relative to the tube pulls the distal sheath proximally to release the stent progressively, starting at the distal end of the stent, the catheter shaft tube being attached to a proximal end zone of the distal catheter component and serving to resist proximal movement of the stent as the outer sheath is pulled proximally, and

characterized by

a casing tube that surrounds the catheter shaft and has a distal end that receives telescopically a proximal end of the distal sheath, with the pull wire fixed to a proximal end zone of the distal sheath within the lumen of the casing tube.

2. Device as claimed in claim 1, wherein the casing tube has a proximal end fixed to a hub of an actuating device.

3. Device as claimed in claim 1 or 2, including a ring that retains the pull wire on the radially outside surface of a proximal end zone of the distal sheath, the ring embracing said radially outside surface of the distal sheath.

4. Device as claimed in any one of the preceding claims, wherein a distal end zone of the pull wire is thinned and given the shape of a part of a cylindrical surface with a radius corresponding to that of the outer cylindrical surface of the distal sheath, whereby the thinned end zone can lie flush, or close to flush, with the radially outside surface of the distal sheath.

5. Device as claimed in any one of the preceding claims, wherein the distal sheath exhibits a diving tube and a distal portion to embrace the covered stent, that distal portion having an open proximal end in which the distal end of the diving tube is fixedly received, the diving tube having a proximal end zone that is telescopically received in the distal open end of the lumen of the casing tube.

6. Device as claimed in any one of the preceding claims, wherein the distal sheath exhibits a distal end to be arranged in use distal of the stent, said distal end tapering radially inwardly to provide an atraumatic tip of the device.

7. A catheter delivery device for a self-expanding stent, with a distal catheter component and a distal sheath that releases the stent by moving proximally relative to the distal catheter component and the stent and which includes a proximal catheter shaft that exhibits a tube and a pull wire within the lumen of the tube, said pull wire being attached to the distal sheath whereby pulling the pull wire proximally relative to the tube pulls the distal sheath proximally to release the stent progressively, starting at the distal end of the stent, the catheter shaft tube being attached to a proximal end zone of the distal catheter component and serving to resist proximal movement of the stent as the outer sheath is pulled proximally, and

characterized by

an inner component that includes a proximal sheath that has a lumen that contains the catheter shaft and has an open distal end that receives a proximal end of the distal catheter component side-by-side with the distal end of the catheter shaft to define a contiguous guidewire lumen that runs the combined length of the lumen of the proximal sheath and a lumen that runs the length of the distal catheter component, thereby to render the delivery system a member of the "over the wire" type.

8. Device as claimed in claim 7, wherein the distal end of the tube carries, to one side of the tube axis, a transferring ring that embraces the proximal end of the distal catheter component.

9. Device as claimed in claim 7 or 8, wherein the distal catheter component extends distally into a stent support tube that is located, in use, inside the lumen of the stent.

10. Device as claimed in claim 9, wherein the distal catheter component has a compound catheter portion that is disposed end-to-end with, and proximal of, the stent support tube and includes a helix of wire that is coaxial with the lumen of the compound catheter component, the helical wire serving to stiffen the compound catheter portion against bending during release of the stent, when the compound catheter portion is in axial endwise compression.

11. Device as claimed in claim 9 or 10, and including a connection tube that receives in its lumen the distal end of the compound catheter portion and the proximal end of the stent support tube, which abut each other, end-to-end, inside the lumen of the support tube.

12. Device as claimed in any one of claims 7 to 11, wherein the distal catheter component includes embossing on its radially outer surface where that is located within the lumen of the stent, the embossing engaging with the luminal surface of the stent for the purpose of resisting relative axial movement of the stent, proximally, relative to the distal catheter component.

13. Catheter delivery device as claimed in any one of claims 1 to 6, with an inner component as defined in any one of claims 7 to 12.

14. A catheter delivery device for a self-expanding stent, with a distal catheter component and a distal sheath that releases the stent by moving proximally relative to the distal catheter component and the stent and which includes a proximal catheter shaft that exhibits a tube and a pull wire within the lumen of the tube, said pull wire being attached to the distal sheath whereby pulling the pull wire proximally relative to the tube pulls the distal sheath proximally to release the stent progressively, starting at the distal end of the stent, the catheter shaft tube being attached to a proximal end zone of the distal catheter component and serving to resist proximal movement of the stent as the outer sheath is pulled proximally, and

characterised by

an inner component that includes a proximal sheath that has a lumen that contains the catheter shaft and has an open distal end that receives a proximal end of the distal catheter component side-by-side with the distal end of the catheter shaft to define a contiguous guidewire lumen that runs the length of the distal catheter component; and

a casing tube that surrounds the catheter shaft and has a distal end that receives telescopically a proximal end of the distal sheath, with the pull wire fixed to a proximal end zone of the distal sheath.

15. A catheter delivery device as claimed in any one of the preceding claims, in which the tube of the proximal catheter shaft, and the proximal end zone of the distal catheter component are both composed substantially or wholly of metal.

16. Device as claimed in claim 14, wherein the said proximal end zone comprises a length portion that exhibits a multitude of slits with their length direction transverse to the length of the distal catheter component, thereby to increase the flexibility in bending of the said proximal end zone the distal catheter component.

17. Device as claimed in claim 15, in which the said slitted length portion extends distally through at least a majority of the distance to the location of the proximal end of the stent.

Fig. 1

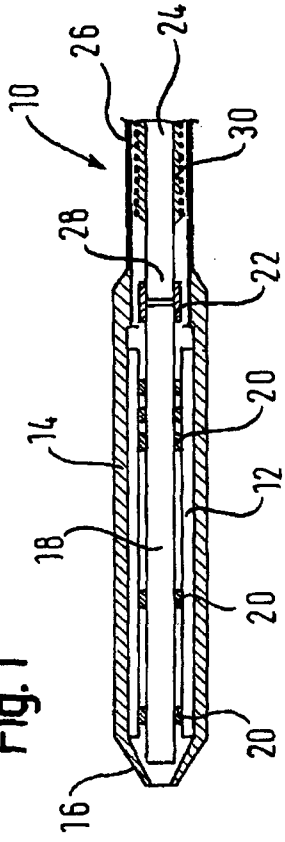

Fig. 2

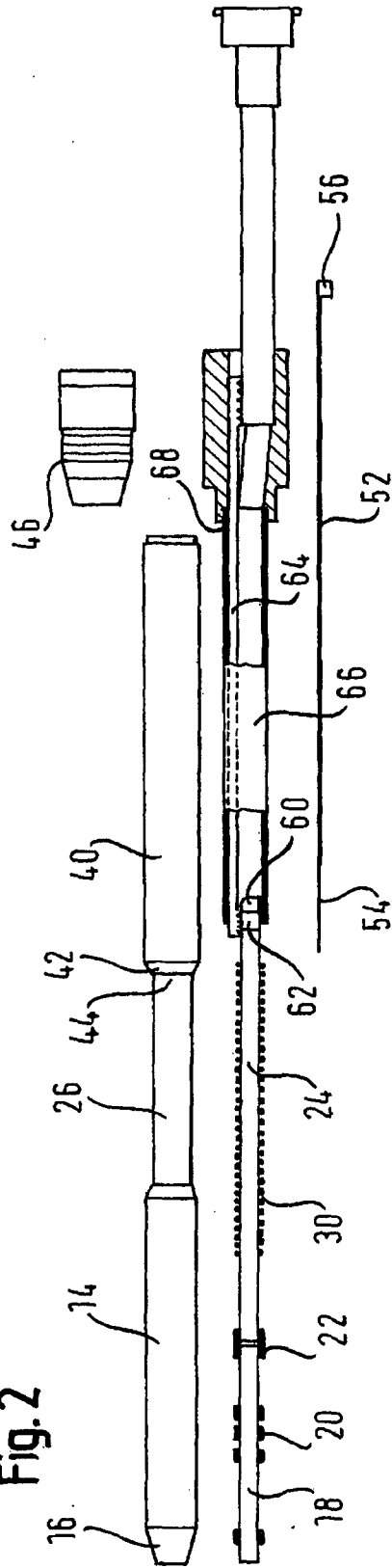
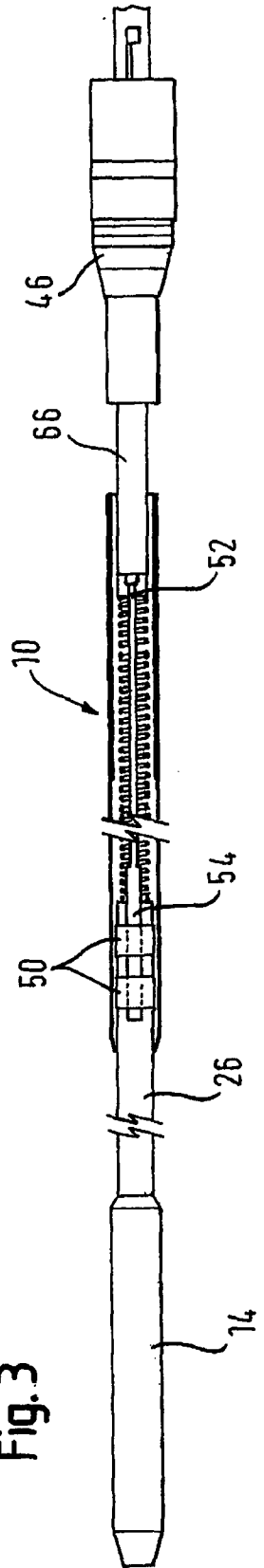
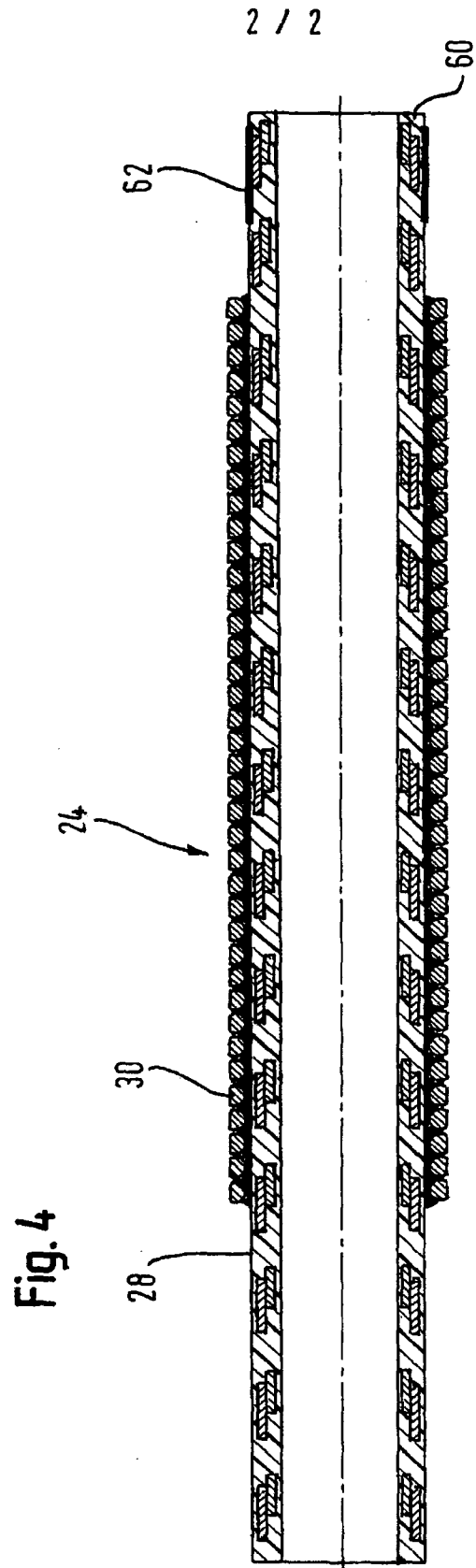

Fig. 3





INTERNATIONAL SEARCH REPORT

International application No
PCT/EP2009/004199

A. CLASSIFICATION OF SUBJECT MATTER
INV. A61F2/84

According to International Patent Classification (IPC) or to both national classification and IPC

B. FIELDS SEARCHED

Minimum documentation searched (classification system followed by classification symbols)
A61F

Documentation searched other than minimum documentation to the extent that such documents are included in the fields searched

Electronic data base consulted during the international search (name of data base and, where practical, search terms used)

EPO-Internal

C. DOCUMENTS CONSIDERED TO BE RELEVANT

Category*	Citation of document, with indication, where appropriate, of the relevant passages	Relevant to claim No.
X	WO 98/12988 A (SCIMED LIFE SYSTEMS INC [US]) 2 April 1998 (1998-04-02) page 5, line 1 - line 3 page 5, line 23 - line 25 page 6, line 5 - line 6 page 6, line 9 - line 18 figures 1-3	1-17
X	EP 1 834 610 A (MEDTRONIC VASCULAR INC [US]) 19 September 2007 (2007-09-19) paragraph [0031] paragraph [0037] figures 2,3	1-17
A	WO 01/78627 A (SCIMED LIFE SYSTEMS INC [US]) 25 October 2001 (2001-10-25) page 11, line 6 - line 11 figures 1,11a	1-17

Further documents are listed in the continuation of Box C.

See patent family annex.

* Special categories of cited documents :

A document defining the general state of the art which is not considered to be of particular relevance

E earlier document but published on or after the international filing date

L document which may throw doubts on priority claim(s) or which is cited to establish the publication date of another citation or other special reason (as specified)

O document referring to an oral disclosure, use, exhibition or other means

P document published prior to the international filing date but later than the priority date claimed

T later document published after the international filing date or priority date and not in conflict with the application but cited to understand the principle or theory underlying the invention

X document of particular relevance; the claimed invention cannot be considered novel or cannot be considered to involve an inventive step when the document is taken alone

Y document of particular relevance; the claimed invention cannot be considered to involve an inventive step when the document is combined with one or more other such documents, such combination being obvious to a person skilled in the art.

* & * document member of the same patent family

Date of the actual completion of the international search

9 October 2009

Date of mailing of the international search report

19/10/2009

Name and mailing address of the ISA/

European Patent Office, P.B. 5818 Patentlaan 2
NL - 2280 HV Rijswijk
Tel. (+31-70) 340-2040,
Fax: (+31-70) 340-3016

Authorized officer

Amaro, Henrique

INTERNATIONAL SEARCH REPORT

Information on patent family members

International application No

PCT/EP2009/004199

Patent document cited in search report	A	Publication date		Patent family member(s)	Publication date
WO 9812988	A	02-04-1998	AT	281799 T	15-11-2004
			AU	4236697 A	17-04-1998
			CA	2263496 A1	02-04-1998
			DE	69731560 D1	16-12-2004
			DE	69731560 T2	24-03-2005
			EP	1006939 A1	14-06-2000
			US	5957930 A	28-09-1999
			US	5772669 A	30-06-1998
<hr style="border-top: 1px dashed black;"/>					
EP 1834610	A	19-09-2007	JP	2007244881 A	27-09-2007
			US	2007219617 A1	20-09-2007
<hr style="border-top: 1px dashed black;"/>					
WO 0178627	A	25-10-2001	AT	387166 T	15-03-2008
			CA	2405386 A1	25-10-2001
			DE	60132982 T2	19-02-2009
			EP	1272125 A1	08-01-2003
			JP	2003530200 T	14-10-2003
			US	6702843 B1	09-03-2004