

H. STOCKMAN.  
LEATHER BLANK CUTTING DIE.  
APPLICATION FILED DEC. 21, 1907.

2 SHEETS—SHEET 1.

Fig. 1

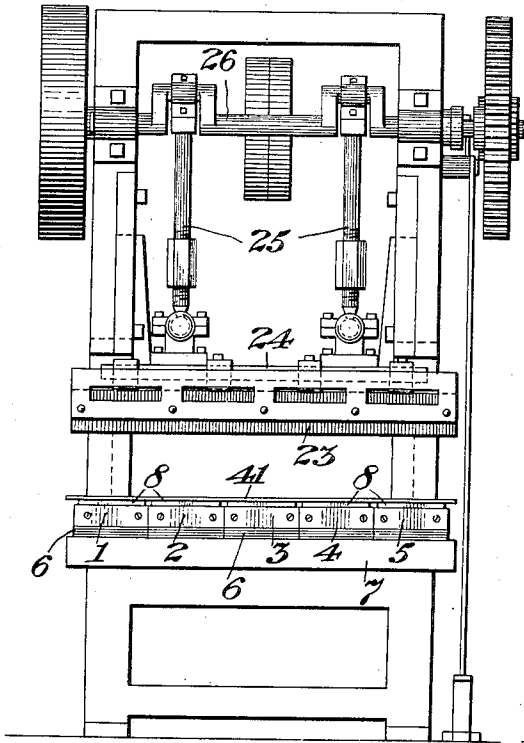

Fig. 2

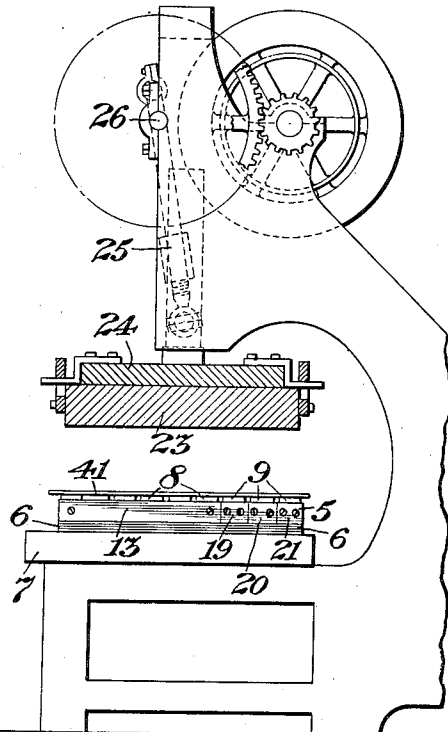

Fig. 3

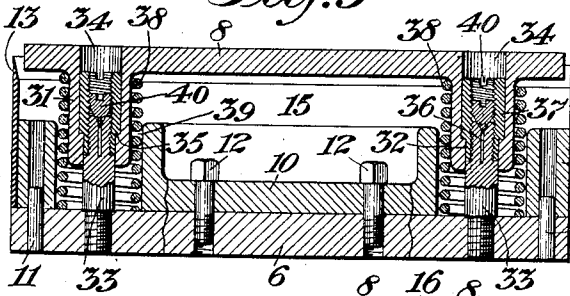

Fig. 4

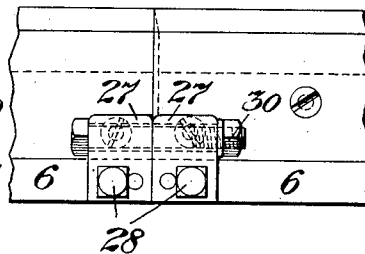
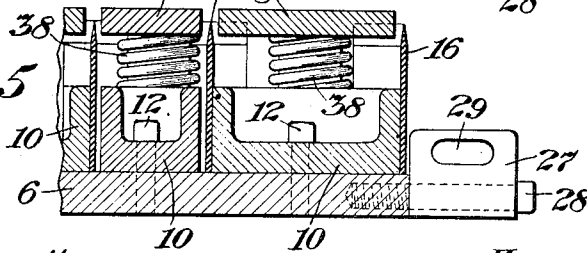

Fig. 5



Witnesses:  
Chas. Clagett  
M. C. Stanton

Inventor  
Henry Stockman  
By his Attorney  
Chas. F. Dane

H. STOCKMAN.  
LEATHER BLANK CUTTING DIE.  
APPLICATION FILED DEC. 21, 1907.

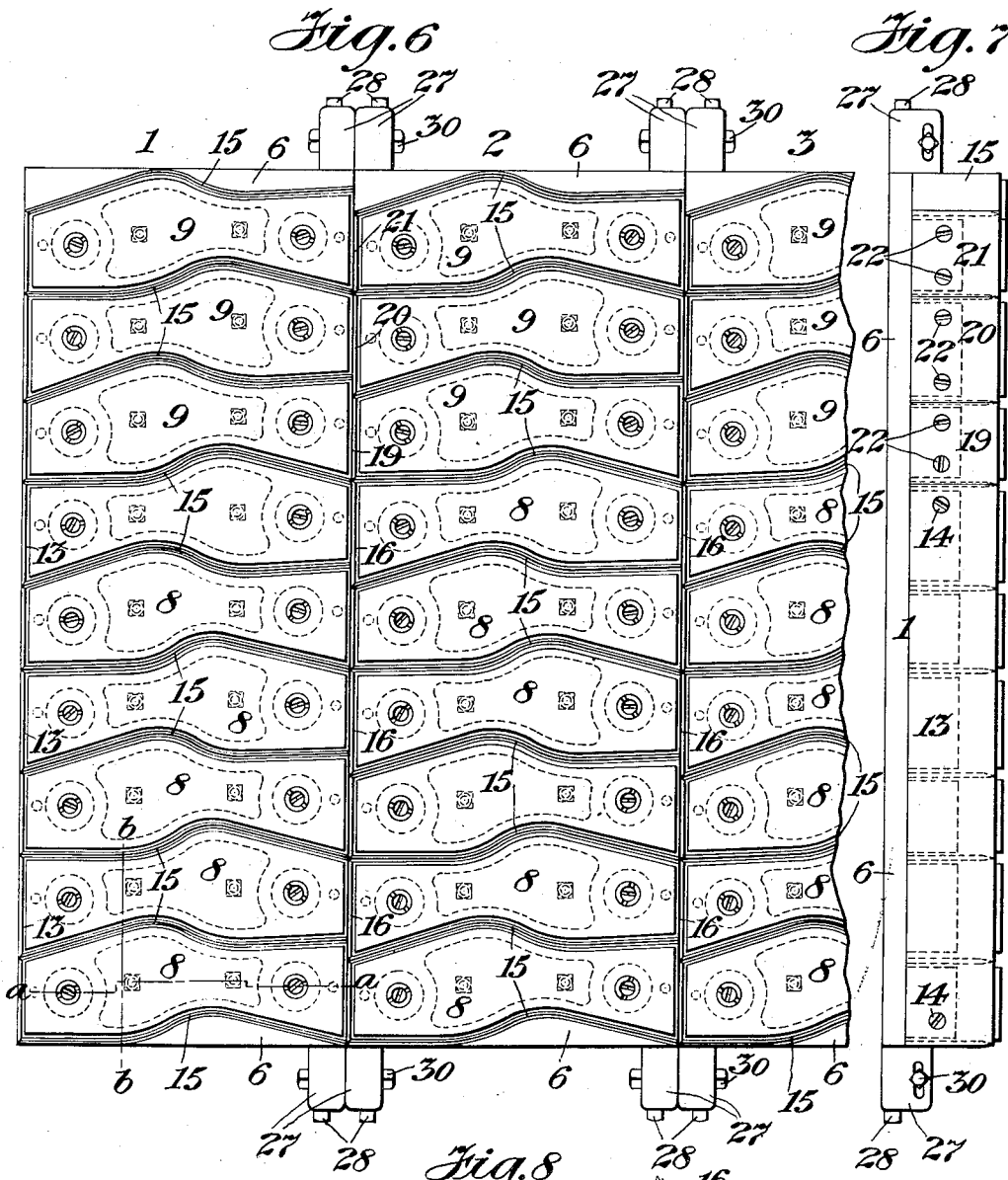

Witnesses:  
*Chas. Claggett*  
*M. E. Stanton*

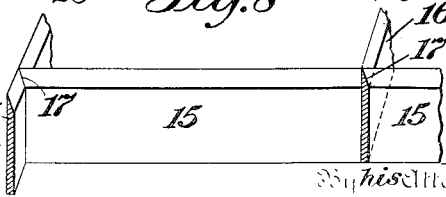

Inventor  
*Henry Stockman*  
 By *his attorney*  
*Chas. F. Dawe*

# UNITED STATES PATENT OFFICE.

HENRY STOCKMAN, OF NEW YORK, N. Y.

## LEATHER-BLANK-CUTTING DIE.

No. 896,478.

Specification of Letters Patent.

Patented Aug. 18, 1908.

Application filed December 21, 1907. Serial No. 407,522.

To all whom it may concern:

Be it known that I, HENRY STOCKMAN, citizen of the United States, and resident of New York, in the county of New York and State of New York, have invented certain new and useful Improvements in Leather-Blank-Cutting Dies, of which the following is a specification.

This invention relates more especially to improvements in the cutting dies and the co-acting cut-blank strippers shown in my prior United States Patent, Number 703,160, granted June 24th 1902, for leather cutting machines.

The present invention has for its more special object to provide for cleanly and simultaneously cutting series of leather sole-blanks in "rights" and "lefts" or with the toe of one blank beside the heel of the adjoining blank to thereby avoid waste of valuable leather stock.

A further object of the invention is to provide a leather cutting die the effective area of which may be easily and widely varied to accommodate larger or smaller leather sides or pieces operated upon and thus avoid unnecessary wear of the cutting block opposing the die knives and also avoid useless wear of knives not actually cutting the blanks while economizing power in using the dies in any suitable press.

A further object of the invention is to simplify and cheapen the knife holders and the blank stripping devices while improving the stripping operation and facilitating easy and precise vertical adjustment of the stripping plates.

The invention comprises certain structural features and operative functions of the leather cutting dies and the blank stripping devices whereby the above named objects are most satisfactorily attained; all as will be hereinafter described and claimed.

Reference is made to the accompanying drawings forming part of this specification, and in which

Figure 1 is a front view of a leather cutting machine equipped with dies embodying the invention. Fig. 2 is a partly broken out sectional side view thereof. Fig. 3 is an enlarged longitudinal vertical section taken on the line *a-a* in Fig. 6. Fig. 4 is a like scale detail front view showing one arrangement of fastenings by which the die sections may be locked together. Fig. 5 is a detail transverse section taken on the line *b-b* in Fig. 6.

Fig. 6 is a plan view to larger scale showing two and one-half of the five die sections illustrated in Figs. 1 and 2. Fig. 7 is an elevational end view of the left-hand die section shown in Fig. 6; and Fig. 8 is a detail perspective view showing the cutting edge junctions of the die knives.

In Figs. 1 and 2 of the drawings the improved dies are applied operatively to a die-press and are grouped to occupy maximum area to the full capacity of the press. As shown there are five die sections 1, 2, 3, 4, 5, each comprising nine blank cutting dies sustained upon any suitable base-plate 6 which rests upon the press bedplate 7. Each die section shown as comprising nine dies is itself made up of one larger part including a lesser number, say six, of permanently grouped blank cutters, and three incremental blank cutters one or two or all of which may be used with the six grouped cutters, as hereinafter more fully described. The left-hand die section 1 and its relations with an adjoining die section will now be described with more special reference to Figs. 3 to 8 of the drawings.

Each of the six permanently grouped blank-cutting dies has an interior blank-stripping plate or table marked 8, while the three incremental dies of each die section each has an interior stripping plate marked 9. The six grouped cutting dies comprise knives secured preferably by laterally ranging screws to inner holders 10, one for each blank die. These holders may be accurately set in place by means of holes in them fitting dowel-pins 11 fixed in the baseplate 6, and the holders then are fixed by bolts 12 to said baseplate. To facilitate easy and inexpensive construction while assuring a single cutting point at the junctions of the die knives with each other, the knives comprising the group of six dies, as shown include one long transverse left-hand knife 13 held preferably by screws 14, 14, to the first and sixth holders 10, as shown in Fig. 7 of the drawings. A series of laterally curved or shaped longitudinal knives 15 at one end abut the said end knife 13, and at their opposite ends abut the longitudinal knives 15 abut the long transverse knife 16 of the next die section 2, which corresponds to the said knife 13 of the first die section. The longitudinal knives 13, 16, are each beveled from their inner face to a cutting edge, and the beveled cutting edge portions of each of the longitudinal knives 15 are fit-

ted closely to the bevels of the knives 13, 16, as most clearly shown at 17 in Fig. 8 of the drawings, thus causing the knife edges to merge to a single cutting point at their junctions with each other to assure a complete or clean cut through the leather stock to produce series of blanks without waste of the valuable material.

A special feature of this invention is the arrangement of the longitudinal die knives 15 to have them simultaneously cut a series of leather sole-blanks in "rights" and "lefts" or with the toe of one blank beside the heel of the adjoining blank to avoid waste of the leather stock. This is effected by laterally curving or shaping the knives 15 and relatively arranging them substantially as shown in Fig. 6 of the drawings. The two opposite long sides of each knife holder 10 are correspondingly shaped and the knives 15 are fastened or fitted tightly in channels between said holders. Said knives 15 may all be originally formed of like steel plates having similar laterally curved or shaped outlines. By reversing the alternate plates end-for-end and then sharpening their upper edges and fitting their bevel-edged parts at 17, to the knives 13, 16, while fastening the knives to their holders 10, the six permanently grouped blank-cutting dies are set up for use. The knives of the three incremental dies inclosing the strippers 9, comprise short end knives 19, 20, 21, each fastened by two screws 22 to the end of the corresponding holder 10, to or at one side of which a laterally curved or shaped longitudinal knife 15 is held. The last or third incremental die has an extra knife 15 forming its outer cutting edge. At points of junction of the die knives 15, 19, 20, 21, between adjacent die sections 1 and 2; 2 and 3, etc., the knives of the incremental dies merge to a single cutting point to cleanly cut the leather stock without waste and substantially as above described for the permanently grouped series of six blank-cutting dies of each die section. The outer right-hand sectional die 5 will at its outer side have long and short knives 13, 19, 20, 21 forming the extreme right-hand cutting edges of the assembled die sections. Should there be used but one die section including a baseplate 6 and a permanently grouped series of six dies 8, with three incremental dies 9, the knives 13, 19, 20, 21 will be duplicated at opposite long sides of this incremental die.

It is obvious that the two end die sections 1, 5, may alone be used, and only with their permanently grouped series of six cutting dies, thus making but twelve blank-cutting dies acting simultaneously. These two die sections also may each carry one or two or all of their incremental dies to correspondingly increase the number of simultaneously cut blanks. One or all of the intermediate die sections 2, 3, 4, also may be adjusted be-

tween the die sections 1, 5, and said intermediate die sections may carry one or more of their incremental dies to correspondingly increase the area of general die surface for cutting as many blanks at once as the size or nature of the leather or other cut material may make desirable or necessary. Or again, only one of the die sections may be used and with or without the long transverse knives 13, 16, and also with or without any incremental dies. By thus relatively combining or adjusting the die sections, useless wear of the wood plunger facing block 23 which is moved against the die knives is avoided, as also is useless wear of knives entering the facing block but not actually cutting blanks, and thus the power required to operate the block-carrying plunger 24 by the pitman 25 coupled to the cranked press shaft 26, is reduced to a minimum.

It is desirable to lock together the die sections 1 to 5 which may at any time be used. This may be done in any approved manner, as for instance by securing lugs 27 by bolts 28 to front and rear ends of the die section baseplates 6. These lugs 27 have slots 29, and when the lugs of two adjacent die sections meet face-to-face, a bolt 30 is passed transversely through the lug slots and is tightened to lock the two die sections together, as shown in the drawings.

In my aforesaid prior patent the upward or outward throw of the blank stripper plates or tables by expanding springs is limited by bolts held loosely at opposite ends in sockets formed in opposed projections on the knife holder and stripper plate and said plate had insufficient support by or from the springs alone against undue lateral play and the plate was therefore fitted with considerable labor between vertical walls of the knife holder to guide its movements. In the here-indescribed improvement the stripper plates have sufficient lateral support by or from the springs and the spring sockets and the plate lugs entering the springs to obviate the necessity of expensively fitting the stripper plates edgewise to the opposed inner walls of the die knives. Furthermore, all danger of injuring more or less delicately faced leather or other stock or material by contact with it of any part of the stripper plate supports is entirely obviated by this invention, all as will now be described with more special reference to Figs. 3 and 5 of the drawings.

At each end the stripper plate 8 or 9 has a pendent lug 31 the lower end of which is bored at 32 to fit movably upon a pin 33 which is fixedly screwed into the die section baseplate 6. Above said bore 32 the lug 31 is counterbored larger at 34 thus providing a shoulder 35. The upper reduced end of the pin 33 is split at 36 and said split end has an exterior screwthread fitting an interior thread made in a plug 37 which loosely fits the coun-

terbore 34 and part of the bore 32 and has a lower shoulder adapted to coact with the lug shoulder 35 to limit upward throw of the stripper plate by a spiral spring 38. This spring surrounds the plate lug 31 and is held at its lowest part within a socket 39 formed in the die knife holder 10 and above the base-plate 6. The lug 31 also enters the socket 39 at the inside of the spring which thus has only vertical play between the lug and socket wall whereby the lug and the spring in the socket mutually support each other laterally to give every necessary lateral steadiness in all directions to the stripper plate 8 or 9 without closely and expensively fitting the plate edgewise within the coacting knives or knife holders. The interior screwthread of the plug 37 also receives matching exterior threads of a lock-nut 40 having a conical inner end adapted to enter the split 36 of the fixed pin 33 and spread its end for binding the pin threads in the plug threads to lock the parts at desired adjustment. Both the plug 37 and the nut 40 have nicks adapted to receive tools for turning them.

It is obvious that when the lock-nut 40 is screwed inward to bind the plug 37 to the pin 33, the expanding spring 38 will force the stripper plate 8 or 9 upward until it is stopped by contact of the upwardly facing lug shoulder 35 with the superposed downwardly facing plug-shoulder. Should it be desired to lower the normal level of the stripper plate in order to increase the tension of the springs 38, or to accommodate wear of the die knives, it only is necessary to first loosen the lock-nuts 40, which allows the plugs 37 to be turned inward on the exterior threads of the fixed pins 33 to the desired extent, whereupon the nuts 40 are again tightened to lock the parts at this new relative adjustment. By these simple means the stripper plates 8 or 9 may be adjusted either inward or outward as occasion may require.

The leather side or part is first laid upon the strippers 8 or 9 which normally lie above the edges of the die knives, and the leather or material is cleanly severed by all the operatively adjusted die sections or parts as the block 23 is forced downward until the knives squarely meet it or slightly enter its face. Immediately the block 23 rises from the die the stripper plates 8 or 9, which had been depressed during the blank-cutting operation, are forced upward again by the springs 38 until stopped by contact of the plate lug shoulders 35 with the opposed shoulders of the plugs 37 which are locked by the nuts 40 to the fixed pins 33.

This invention may be modified within the scope of any one or more of the appended claims.

What I claim is:

1. A die for leather cutting machines comprising a plurality of groups of longitudinally

arranged cutting knives, opposed parallel transverse cutting knives, which span a series of said groups to form a permanent die section, and a series of opposed parallel transverse cutting knives for each of the succeeding groups of longitudinal knives to form incremental die sections.

2. A die for leather cutting machines comprising a plurality of knife-holders, opposed "right" and "left" sole cutting knives carried by each holder, opposed parallel cutting knives secured to said holders and spanning a plurality of said "right" and "left" knives transversely to form a permanent die-section, and opposed parallel transverse cutting knives separately secured to each of the succeeding holders to span the longitudinal knives thereon and form incremental die sections.

3. A die for leather cutting machines comprising a base-plate, knife-holder centering and securing means thereon, a series of removable knife-holders, opposed "right" and "left" sole cutting knives carried by each holder, opposed parallel cutting knives secured to said holders and spanning a plurality of said "right" and "left" knives to form a permanent die-section, and a series of opposed parallel cutting knives separately secured to each of the succeeding holders to span the pair of "right" and "left" knives thereon and form incremental die-sections.

4. In a cutting die of the character described, the combination with the knives and their relatively fixed supports, of a stripper plate having pendent lugs each provided with an interior upwardly facing shoulder, expanding springs surrounding said lugs and located partly in sockets of the knife supports, pins fixed relative to and extending into said sockets, and plugs fitting said pins within the stripper plate lugs and having exterior shoulders opposing the interior shoulders of said lugs; said plugs being vertically adjustable on the fixed pins, substantially as described.

5. In a cutting die of the character described, the combination with the knives and their relatively fixed supports, of a stripper plate having pendent lugs each provided with an interior upwardly-facing shoulder, expanding springs surrounding said lugs and located partly in sockets of the knife supports, pins fixed relative to and extending into said sockets having upper exterior screwthreads, and plugs having interior threads fitting the fixed pin threads and also having underfacing shoulders opposing the lug shoulders, whereby the yielding stripper plate may be vertically adjusted by turning the plugs on the fixed pins, substantially as described.

6. In a cutting die of the character described, the combination with the knives and their relatively fixed supports, of a stripper

plate having pendent lugs each provided  
with an interior upwardly-facing shoulder,  
expanding springs surrounding said lugs and  
located partly in the sockets of the knife sup-  
5 ports, fixed pins in said sockets having upper  
exterior screwthreads and also having split  
upper ends, plugs having interior threads  
fitting the fixed pin threads and also having  
under-facing shoulders opposing the lug  
10 shoulders, and lock-nuts fitting the interior  
threads of the shouldered plugs and adapted  
to spread the split threaded ends of the fixed

pins, whereby the yielding stripper plate may  
be vertically adjusted by turning the plugs  
on the fixed pins and may then be secured 15  
by the lock-nuts, substantially as described.

Signed at New York, in the county of New  
York, and State of New York, this 20 day of  
Sept., A. D. 1907.

HENRY STOCKMAN

Witnesses:

CHAS. F. DANE,  
M. E. STANTON.