



US 20040216506A1

(19) **United States**

(12) **Patent Application Publication**  
**Simpson et al.**

(10) **Pub. No.: US 2004/0216506 A1**

(43) **Pub. Date: Nov. 4, 2004**

(54) **TUBING EXPANSION**

(30) **Foreign Application Priority Data**

(76) Inventors: **Neil Andrew Abercrombie Simpson**,  
Aberdeen (GB); **Wayne Rudd**,  
Newcastle Upon Tyne (GB)

Mar. 25, 2003 (GB)..... 0306774.1

May 29, 2003 (GB)..... 0312278.5

**Publication Classification**

(51) **Int. Cl.<sup>7</sup>** ..... **B21D 39/08**

(52) **U.S. Cl.** ..... **72/370.06**

(57) **ABSTRACT**

A method of expanding tubing comprises locating an expansion device in tubing to be expanded, vibrating one or both of the tubing and the expansion device, and translating the expansion device relative to the tubing, the vibration acting to reduce friction between the tubing and the device.

Correspondence Address:

**WILLIAM B. PATTERSON**  
**MOSER, PATTERSON & SHERIDAN, L.L.P.**  
**Suite 1500**  
**3040 Post Oak Blvd.**  
**Houston, TX 77056 (US)**

(21) Appl. No.: **10/809,036**

(22) Filed: **Mar. 25, 2004**

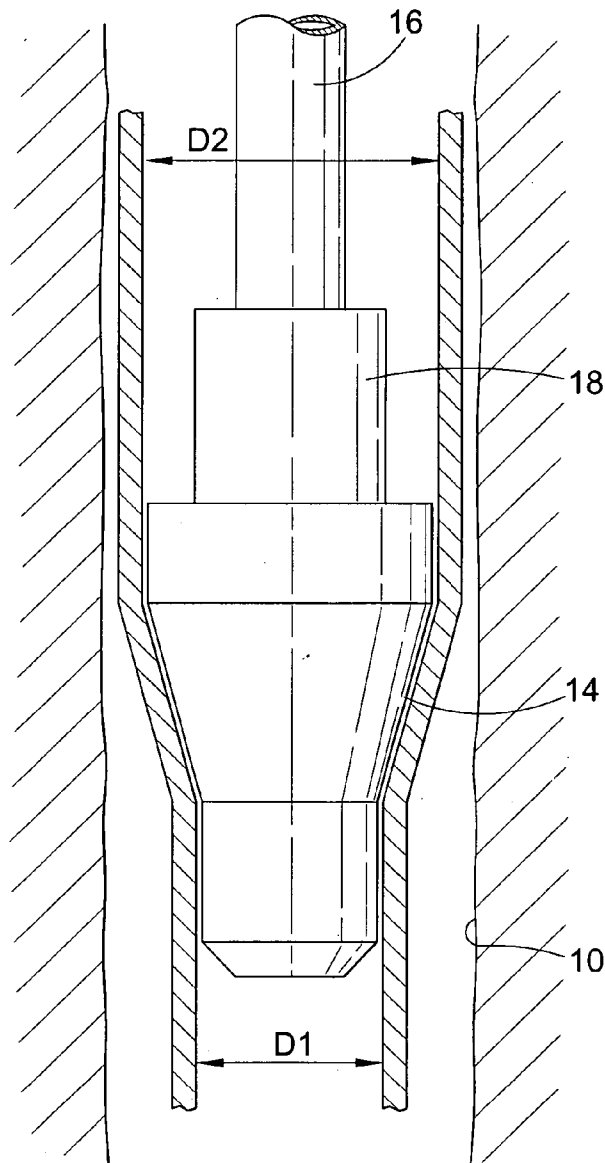

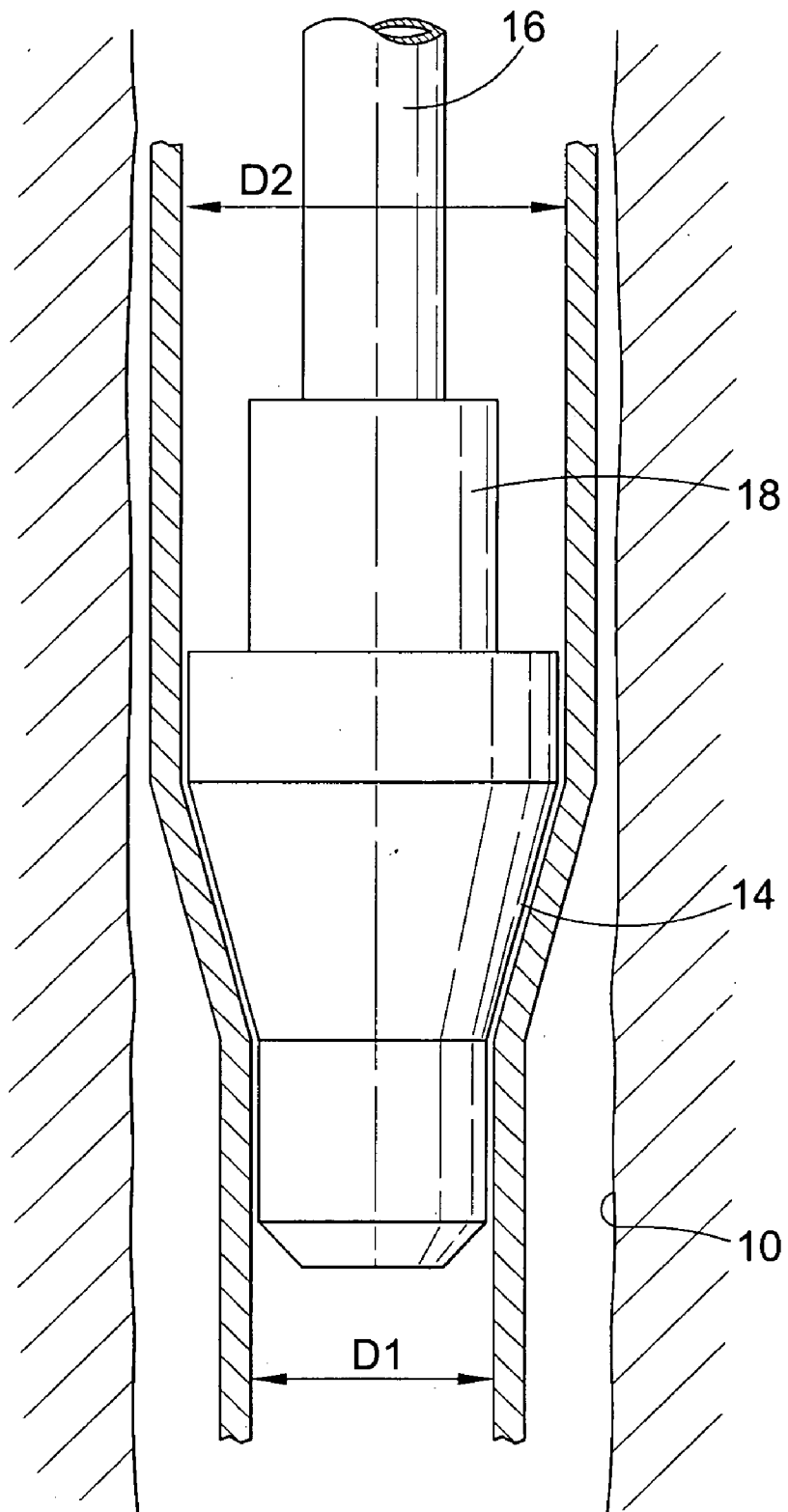

**TUBING EXPANSION**

**CROSS-REFERENCE TO RELATED APPLICATIONS**

[0001] This application claims benefit of Great Britain patent application serial number GB 0306774.1, filed Mar. 25, 2003, and Great Britain patent application serial number GB 0312278.5, filed May 29, 2003, which is herein incorporated by reference.

**BACKGROUND OF THE INVENTION**

[0002] 1. Field of the Invention

[0003] This invention relates to tubing expansion. In particular, but not exclusively, the invention relates to diametric expansion of tubing downhole.

[0004] 2. Description of the Related Art

[0005] One of the most significant recent developments in the oil and gas exploration and production industry has been the introduction of technology which allows for expansion of extended sections of tubing downhole. The tubing may take different forms, including but not restricted to: expandable casing, liner, sandscreen, straddles, packers and hangers. A variety of expansion methods have been proposed, including use of expansion cones or mandrels which are forced through the tubing. One difficulty which has been experienced with cone expansion is the high level of friction and wear between the surface of the cone and the inner surface of the tubing to be expanded.

[0006] It is among the objectives of embodiments of the present invention to obviate or mitigate this difficulty.

**SUMMARY OF THE INVENTION**

[0007] According to the present invention there is provided a method of expanding tubing, the method comprising:

[0008] locating an expansion device in tubing to be expanded;

[0009] vibrating at least one of the tubing and the expansion device; and

[0010] translating the expansion device relative to the tubing.

[0011] The vibration of at least one of the tubing and the expansion device preferably acts to reduce friction between the tubing and the device.

[0012] In conventional tubing expansion operations an expansion device which slides relative to the tubing to be expanded, such as a cone or mandrel, will tend to progress through the tubing incrementally in a series of small steps. From a static condition, the load on the cone is increased until the load is sufficient to drive the cone through the tubing. In addition to the forces required to expand the tubing diametrically, it is also necessary to overcome the static friction between the contacting surfaces of the cone and the tubing before the cone will move relative to the tubing. Once static friction has been overcome, frictional resistance to movement typically decreases sharply due to the lower dynamic friction between the contacting surfaces, such that the initial movement of the cone will tend to be

relatively rapid. As the cone moves forward rapidly relative to the tubing, the driving force being applied to the cone will tend to fall, the inertia of the cone-driving arrangement being such that the cone-driving arrangement will typically fail to keep pace with the cone. Thus, after the initial rapid movement, the cone will tend to stall as the driving force decreases. The driving force applied to the cone then increases once more, moving the cone forward again once static friction between the cone and tube is overcome. For brevity, this form of movement will hereinafter be referred to as "stick-slip".

[0013] With the present invention, the vibration of one or both of the expansion device and the tubing is intended such that there will be little or no static friction experienced between the contacting surfaces, and the conventional stick-slip progression of the expansion device relative to the tubing should be avoided. The driving force necessary to drive the expansion device through the tubing should therefore remain relatively constant, as the frictional forces remain at a relatively constant, and relatively low, level.

[0014] Furthermore, the reduction in friction between the expansion device and the tubing should tend to decrease the wear experienced by the expansion device, which in conventional expansion operations may place limits on the length of tubing which can be expanded in a single expansion operation.

[0015] Of course, in downhole applications, the vibration may also serve to assist in reducing the occurrence of differential sticking between the tubing and the surrounding bore wall.

[0016] The frequency and amplitude of vibration may be selected to suit each particular application. Furthermore, the direction of vibration may be selected as appropriate: for example, the vibration may be random, multi-directional, axial, transverse or rotational. In one embodiment of the invention the vibration is substantially perpendicular to the surface of the expansion device, and in another embodiment the vibration takes the form of torsional oscillations.

[0017] Where the expansion device is vibrated, all or a major portion of the device may be subject to vibration. Alternatively, only a selected portion of the device may be subject to vibration, for example only a surface portion of the device, or only a selected area of the surface of the device, may be subject to vibration. Portions of the expansion device may also experience different degrees or forms of vibration.

[0018] If the tubing is vibrated, all or a substantial portion of the tubing may be vibrated. Alternatively, only a selected portion of the tubing may be vibrated. For example, only a portion of the tubing at or adjacent the expansion device may be vibrated, or only a surface portion of the tubing may be vibrated.

[0019] The vibration of the expansion device or tubing may induce physical movement of the device or tubing. Alternatively, or in addition, the vibration of the device or tubing may induce contraction and expansion of all or a portion of the device or the tubing. For example, the vibration may take the form of one or more waves traveling through the device or tubing.

[0020] The vibration of the expansion device or tubing may induce physical movement of the device or tubing.

Alternatively, or in addition, the vibration of the device or tubing may induce contraction and expansion of all or a portion of the device or the tubing. For example, the vibration may take the form of one or more waves traveling through the device or tubing.

[0021] The vibration may be induced or created locally relative to the expansion device or the tubing being expanded, or may be created remotely, for example a wave form oscillation may be created remote from the expansion device location, and then travel along or through the tubing wall, or travel to the expansion location via another medium.

[0022] The vibration may be created by any appropriate means, including: an oscillating or otherwise moving mass; creating a varying or cyclic restriction to fluid flowing through the expansion device or tubing; an electromagnetic oscillator; varying the pressure of fluid operatively associated with the device or tubing; creating pressure pulses in a fluid; or injecting gas or liquid or a mixture of both into fluid operatively associated with the device or tubing.

[0023] The source of vibration or oscillation may be directly or indirectly coupled to one or both of the expansion device and the tubing.

[0024] The vibration may be of a constant, varying or substantially random nature, that is the amplitude, direction, frequency and form of the vibration may be constant, varying or random.

[0025] The vibration or oscillation may be of high frequency, for example ultrasonic. Such vibration may not be apparent as physical movement, as the vibration may be at a molecular or macromolecular level, or at least at a level below that of readily detectable physical movement of the device or tubing. Such vibration may be induced electromagnetically, for example by a varying electromagnetic field, or a varying or alternating current or voltage. Alternatively, or in addition, the vibration or oscillation may be of relatively low frequency, for example in the range of 1 to 100 Hz. If desired, the vibration may comprise a plurality of different components, for example a low frequency component and a high frequency component.

[0026] The vibration may be selected to coincide with a natural frequency of the expansion device or the tubing, or another element of apparatus. Alternatively, the vibration may be selected to avoid such natural frequency or frequencies.

[0027] The expansion device may be translated relative to the tubing by any appropriate means. The device may be mounted on a support which allows the device to be pushed, pulled or otherwise driven through the tubing. The support may extend from a downhole location to surface, where a pushing, pulling or torsional force may be applied. Alternatively, the expansion device may be coupled to a tractor or other driving arrangement located downhole. Alternatively, or in addition, fluid pressure may be utilised to move the device relative to the tubing.

[0028] The expansion device may take any appropriate form and may utilise any appropriate expansion mechanism, or a combination of different expansion mechanisms. An expansion cone or mandrel may be utilised with an expansion surface adapted for sliding or rolling contact with the tubing wall. The cone may be adapted for axial movement

relative to the tubing, but may also be adapted for rotation. Alternatively, or in addition, a rotary expander may be utilised, that is a device which is rotated within the tubing with at least one expansion member, typically a roller, moving around the surface of the tubing and creating localised compressive yield in the tubing wall, the resulting reduction in wall thickness leading to an increase in tubing diameter.

[0029] The expansion device may define a fixed diameter, or a variable diameter. The device may be compliant, that is the device has a degree of flexibility to permit the device to, for example, negotiate sections of the tubing which cannot be expanded to a desired larger diameter or form. Alternatively, the expansion device may define a fixed diameter and may be non-compliant. In certain embodiments, the expansion device may feature both fixed and compliant elements.

[0030] References herein to expansion are primarily intended to relate to diametric expansion achieved by thinning of tubing wall. However, embodiments of the invention may also relate to tubing which is expanded by reforming a tubing wall, for example by straightening or smoothing a corrugated tubing wall, or other expansion mechanisms.

[0031] In other embodiments of the invention the expansion process may be supplemented by the application of an elevated fluid pressure, and in particular a varying fluid pressure, to the tubing.

[0032] The varying fluid pressure preferably acts across the wall of the tubing. The variation in pressure may be achieved by any appropriate means, and one or both of the fluid pressure within the tubing and the fluid pressure externally of the tubing may be varied. A body of varying volume may be located in a volume of fluid operatively associated with the tubing. Alternatively, or in addition, the volume of a body of fluid operatively associated with the tubing may be varied by movement of a wall portion defining a boundary of the volume, which wall portion may be operatively associated with an oscillator or a percussive or hammer device. In other embodiments a pressurised fluid source may be provided, and the fluid may be supplied at varying pressure from the source or the manner in which the fluid is delivered to the tubing from the source may be such as to vary the fluid pressure. An increase in pressure within the tubing may be accompanied by a reduction in pressure externally of the tubing, or a reduction of pressure externally of the tubing may occur independently of any variations in the internal pressure, which may remain substantially constant.

[0033] In one embodiment, in a downhole application, the fluid pressure externally of the tubing may be maintained at a relatively low level by providing a relatively low density fluid externally of the tubing. Thus, the hydrostatic pressure produced by the column of fluid above the tubing will be relatively low. This may be achieved by injecting gas or low density fluid into fluid surrounding the tubing. Alternatively, or in addition, a volume of fluid externally of the tubing may be at least partially isolated from the head of fluid above the tubing, for example by means of a seal or seals between the tubing and a surrounding bore or tubing wall, or by providing pumping means above the tubing.

[0034] Alternatively, or in addition, the fluid pressure internally of the tubing may be maintained at a relatively high level by providing a relatively high density fluid internally of the tubing.

[0035] Tubing expansion operations are typically carried out using conventional, readily available fluids, such as seawater or completion brine, which may have a specific gravity (SG) of approximately 1.025. However, the SG of fluids used in downhole operations of course varies depending on, for example, the choice of base fluid and the presence of weight materials or other additives, and may range from 0.85 to 2.2. Thus, references herein to high and low density fluids should be related primarily to fluids utilised in conventional tubing expansion operations and other downhole operations where the fluid is selected with reference primarily to other requirements, including availability and ease of handling. Accordingly, by way of example, with reference to expansion operations which, using conventional expansion techniques, would be carried out in the presence of completion brine, a high density fluid may be one having an SG in excess of around 1.025 and a low density fluid may be one having an SG less than around 1.025. In other cases, the density of a fluid present within tubing to be expanded may be considered to be relatively high if the fluid has been selected with reference to the lower density of the fluid in the annulus surrounding the tubing. Similarly, the density of a fluid in the annulus may be considered to be relatively low if the density is lower than the density of the fluid present within the tubing to be expanded. Of course the invention is not limited to use with liquids, and in some cases one or both of the fluids, particularly where a lower density fluid is required, may be a gas such as natural gas or air, or a multiphase fluid.

[0036] The portion of tubing to be expanded may be isolated from ambient fluid by one or more appropriate seals, and a varying pressure differential may be maintained across each seal. However, in accordance with a further aspect of the invention a degree of leakage past the seals may be permissible, and in some cases may even be desirable, particularly if means for providing or creating a cycling fluid pressure is being utilised; if the frequency or rate of pressure variation is sufficiently high, a degree of leakage, and the corresponding pressure decay, will not adversely affect the expansion process and may assist in providing the desired pressure cycling when combined with an appropriate source of pressure. In particular, the method may include the step of producing a pressure pulse, and thus an elevated fluid pressure, which then reduces or decays, as leakage occurs across the seal. Furthermore, the ability to utilise "leaky" seals tends to facilitate use of the expansion method, as there are difficulties involved in providing a fully effective seal in many environments: when expanding tubing downhole, the tubing will often not be perfectly cylindrical, and the tubing diameter may be variable; the tubing surface is unlikely to be perfectly smooth, and may include profiles; the ambient fluid in the tubing may contain particulates and contaminants; and in preferred embodiments the seal will move relative to the tubing as the tubing is expanded, which movement would of course result in wear to one or both of the seal and the tubing, and which movement would have to overcome friction, which could be considerable if a leak-free seal was provided or required. Also, the leakage of fluid around and over the seal will provide lubrication, facilitating relative movement between the seal and the tubing.

[0037] The seal may take any appropriate form, but is preferably in the form of a labyrinth seal. Typically, the seal comprises a plurality of seal members, each seal member adapted to maintain a proportion of the total pressure

differential across the seal. The number of seal members may be selected depending upon a number of considerations, including the form of the seal members, tubing form and condition, ambient conditions, the pressure differential to be maintained, tubing diameter, and the frequency or rate of variation of the fluid pressure. Of course such a seal configuration may also be suitable for use in situations where the fluid pressure is substantially constant, or is maintained above at least a minimum level, provided of course that means is provided for maintaining the expansion pressure at the desired level, despite leakage past the seal. Thus, perhaps five, ten, fifteen or more seal members may be provided, as appropriate. The number of seal members may be selected to provide for redundancy, such that failure or damage of one or more seal members will not adversely affect the expansion process.

[0038] The fluid pressure may be maintained at a base pressure, for example at 70% of the yield pressure of the wall of the tubing, upon which base pressure additional pressure pulses or spikes are superimposed, taking the fluid pressure to or in excess of 100% of the yield pressure, to induce plastic deformation of the tubing.

[0039] The mechanical expansion or reforming device, such as an expansion cone, mandrel or die, or a rotary expansion device, may exert only a small expansion force, and may merely serve to stabilise the expansion process and assist in achieving a desired expanded form, for example achieving a desired expanded diameter and avoiding ovality. Alternatively, or in addition, the mechanical expansion or reforming device may serve to retain expansion induced by the elevated fluid pressure. In one embodiment, a shallow angle cone may be advanced through the expanding tubing, the cone preferably being advanced in concert with the periods of elevated pressure. The cone angle may be selected depending upon the particular application, but for downhole tubulars of conventional form it has been found that an 11 degree cone angle results in a cone which retains expansion, that is the cone may be advanced into the tubing expanded by the elevated pressure, and is then retained in the advanced position as the tubing contracts on decay of the fluid pressure below the tubing wall yield pressure. It is anticipated that by cycling the fluid pressure at a rate of around 5 Hertz the cone will advance at a rate of approximately 6 to 8 feet per minute. Of course the rate or frequency of fluid pressure variation may be selected to suit local conditions and equipment. Such advancement may be achieved by providing separate mechanical drive means but may be conveniently achieved by virtue of the pressure differential over a seal coupled to the cone; as the pressure peaks, causing expansion of the tubing, the axial differential pressure acting force across the seal will also peak. Where the cone is located between seals, in particular a leading seal and a trailing seal, the leading seal may be mounted on the cone or otherwise coupled to the cone such that any pressure differential across the seal will tend to urge the cone forward. The trailing seal may be located at some point behind the cone, such that the cone is located within an isolated fluid volume between the seals. The trailing seal may be fixable or securable relative to the tubing or may be floating. The trailing seal may be retained in position mechanically or, alternatively or additionally, by fluid pressure, for example by a column of fluid above the seal, which column may be pressurised by appropriate pumps on surface. The variations in pressure are preferably applied to the isolated fluid

volume between the seals, and may be created by a pulse generator located within the isolated volume, or by supplying elevated pressure fluid or pressure pulses from a source externally of the isolated volume. In other embodiments, variations in pressure may also be applied to one or both of the fluid volumes above and below the isolated volume.

[0040] Of course the presence of fluid will facilitate movement of any expansion device present relative to the tubing, in particular by serving as a lubricant between the contacting surfaces of the expansion device and the tubing. The fluid may be selected for its lubricating properties. This is particularly the case in embodiments where the fluid surrounding the expansion device is at least partially isolated from the ambient fluid, and as such a smaller volume of fluid selected for its particular properties may be provided. Leakage past isolating seals may be accommodated by providing a larger initial volume, or by supplying further fluid to the volume. Of course the fluid may be selected with properties other than lubrication in mind, for example the fluid may comprise or include a relatively viscous element, for example a grease, to minimize the rate of leakage and pressure decay. Downhole expansion may be accomplished either top down or bottom up, that is expansion process moves downwardly or upwardly through the tubing.

#### BRIEF DESCRIPTION OF THE DRAWINGS

[0041] These and other aspects of the present invention will now be described, by way of example, with reference to the accompanying drawing, which is a schematic illustration of a tubing expansion operation, in accordance with a preferred embodiment of the present invention.

#### DETAILED DESCRIPTION OF THE PREFERRED EMBODIMENT

[0042] The figure illustrates a subterranean bore **10**, such as may be drilled to gain access to a subsurface hydrocarbon reservoir. After drilling, the bore **10** may be lined with metal tubing, sometimes known as liner or casing. In the illustrated embodiment, a section of expandable casing **12** has been run into the bore **10**, and once located in the bore **10** the casing **12** is expanded from a smaller first diameter **D1** to a larger second diameter **D2**.

[0043] The expansion is achieved by means of driving an expansion cone **14** down through the casing **12**, the cone **14** being mounted on a string of drill pipe **16** which extends to surface. The force necessary to drive the cone **14** through the casing **12** while expanding the casing **12** is considerable: the force must be sufficient to deform the casing **12** and also to overcome the friction between the contacting surfaces of the cone **14** and the casing **12**. In conventional cone expansion operations the level of friction experienced is such that the cone **14** will tend to progress with an inefficient stick-slip movement, due in part to the differences in static and dynamic friction experienced by the cone **14** as it is moved through the casing **12**. However, in the present invention, this difficulty is substantially avoided due to the vibration of the cone **14** by means of an oscillator **18** mounted to the cone **14**. In use, the oscillator **18**, which is powered from surface via an appropriate control line, produces oscillations at ultrasonic frequencies, which vibrations or oscillations are transferred to the cone **14**. This high frequency of vibration of the cone **14** is such that there is substantially constant

relative movement between the contacting surfaces of the cone **14** and the casing **12**, such that there is no static friction experienced between the contacting surfaces. Thus, the level of friction between the cone **14** and the casing is relatively low, allowing the cone **14** to progress through the casing **12** at a relatively constant rate, in response to a relatively constant applied force.

[0044] It will be apparent to those of skill in the art that the above-described embodiment is merely exemplary of the present invention, and that various modifications and improvements may be made thereto without departing from the scope of the present invention.

[0045] In other embodiments, the casing **12** rather than the cone **14** may be vibrated, and the manner in which the vibration or oscillation is created may be varied. For example, fluid may be pumped through the drill pipe **16** and the fluid flow path may be interrupted or varied to induce vibration. Alternatively, a stream of gas may be injected into the fluid surrounding the cone **14**, causing vibration of one or both of the cone **14** and the casing **12**.

[0046] In other embodiments of the invention translation of the cone **14** through the casing may be achieved at least in part by application of a fluid pressure, which fluid pressure may also assist in expanding the casing **12**. The fluid pressure may be varied such as to vibrate one or both of the cone **14** or casing, or to assist in the expansion of the casing, as described in greater detail in our patent application GB 0306774.1 entitled "Hydraulically Assisted Tubing Expansion", the disclosure of which is incorporated herein by reference.

1. A method of expanding tubing, the method comprising:

locating an expansion device in tubing to be expanded;  
vibrating at least one of the tubing and the expansion device; and

translating the expansion device relative to the tubing.

2. The method of claim 1, wherein the nature of the vibration of at least one of the tubing and the expansion device is selected to reduce friction between the tubing and the device.

3. The method of claim 2, wherein the vibration of at least one of the expansion device and the tubing is selected to substantially avoid static friction between contacting surfaces of the expansion device and the tubing.

4. The method of claim 1, wherein a driving force is applied to translate the expansion device through the tubing.

5. The method of claim 4, wherein the driving force remains substantially constant as the expansion device is translated through the tubing.

6. The method of claim 1, wherein the direction of the vibration includes an element selected from at least one of: random, multi-directional, axial, transverse and rotational.

7. The method of claim 1, wherein at least a major portion of the expansion device is subject to vibration.

8. The method of claim 1, wherein only a selected portion of the expansion device is subject to vibration.

9. The method of claim 8, wherein a surface portion of the device is subject to vibration.

10. The method of claim 1, wherein portions of the expansion device experience different forms of vibration.

11. The method of claim 1, wherein at least a substantial portion of the tubing is vibrated.

12. The method of claim 1, wherein only a selected portion of the tubing is vibrated.

13. The method of claim 12, wherein a portion of the tubing adjacent the expansion device is vibrated.

14. The method of claim 12, wherein a surface portion of the tubing is vibrated.

15. The method of claim 1, wherein the vibration induces physical movement of at least one of the expansion device and tubing.

16. The method of claim 1, wherein the vibration induces contraction and expansion of at least a portion of at least one of the expansion device and the tubing.

17. The method of claim 1, wherein the vibration takes the form of at least one wave traveling through at least one of the expansion device and the tubing.

18. The method of claim 1, wherein the vibration is created locally relative to the tubing being expanded.

19. The method of claim 1, wherein the vibration is created remotely of a tubing expansion location, and travels to the expansion location.

20. The method of claim 1, comprising creating the vibration with a moving mass.

21. The method of claim 1, comprising creating the vibration by providing a varying restriction to fluid flowing through at least one of the expansion device and the tubing.

22. The method of claim 1, comprising creating the vibration with an electromagnetic oscillator.

23. The method of claim 1, comprising creating the vibration by varying the pressure of fluid operatively associated with at least one of the device and the tubing.

24. The method of claim 1, comprising creating the vibration by creating pressure pulses in a fluid operatively associated with at least one of the device and the tubing.

25. The method of claim 1, comprising creating the vibration by injecting fluid into fluid operatively associated with at least one of the device and the tubing.

26. The method of claim 1, comprising coupling a source of vibration to at least one of the expansion device and the tubing.

27. The method of claim 26, comprising directly coupling a source of vibration to at least one of the expansion device and the tubing.

28. The method of claim 26, comprising indirectly coupling a source of vibration to at least one of the expansion device and the tubing.

29. The method of claim 1, wherein the amplitude of the vibration is selected from at least one of constant, varying and random amplitude.

30. The method of claim 1, wherein the frequency of the vibration is selected from at least one of constant, varying and random frequency.

31. The method of claim 1, wherein the form of the vibration is selected from at least one of constant, varying and random form.

32. The method of claim 1, wherein the vibration is of high frequency.

33. The method of claim 32, wherein the vibration is ultrasonic.

34. The method of claim 1, wherein the form of the vibration is selected such that the vibration is not apparent as physical movement.

35. The method of claim 1, wherein the vibration is induced electromagnetically.

36. The method of claim 1, wherein the vibration is of relatively low frequency.

37. The method of claim 36, wherein the vibration is in the range of 1 to 100 Hz.

38. The method of claim 1, wherein the vibration comprises a plurality of different components.

39. The method of claim 38, wherein the vibration comprises a low frequency component and a high frequency component.

40. The method of claim 1, wherein the vibration is selected to coincide with a natural frequency of at least one of the expansion device and the tubing.

41. The method of claim 1, wherein the vibration is selected to avoid a natural frequency of at least one of the expansion device and the tubing.

42. The method of claim 1, comprising applying a driving force to the expansion device to translate the expansion device relative to the tubing.

43. The method of claim 1, comprising applying a mechanical driving force to translate the expansion device relative to the tubing.

44. The method of claim 43, wherein the driving force comprises at least one of a pulling, pushing and torsional force.

45. The method of claim 1, comprising applying a fluid pressure driving force to translate the expansion device relative to the tubing.

46. The method of claim 1, wherein the expansion device is in sliding contact with the tubing.

47. The method of claim 1, wherein the expansion device is in rolling contact with the tubing.

48. The method of claim 1, wherein the expansion device is translated axially relative to the tubing.

49. The method of claim 1, wherein the expansion device is translated rotationally relative to the tubing.

50. The method of claim 1, comprising expanding the tubing by creating localized compressive yield in the tubing wall.

51. The method of claim 1, comprising varying the diameter of the expansion device.

52. The method of claim 1, further comprising creating a pressure differential across a wall of the tubing.

53. The method of claim 52, wherein the pressure differential applied across the tubing wall is varied.

54. The method of claim 53, wherein the pressure differential is cycled.

55. The method of claim 1, comprising isolating a volume of fluid containing the expansion device.

56. A method of expanding tubing, the method comprising:

locating an expansion device in tubing to be expanded;  
vibrating the expansion device; and

translating the expansion device relative to the tubing.

57. Apparatus for expanding tubing, the apparatus comprising:

an expansion device; and

means for vibrating at least one of the tubing and the expansion device.

58. The apparatus of claim 57, further comprising means for translating the expansion device relative to the tubing.

59. The apparatus of claim 57, wherein the vibrating means is operable to reduce friction between the tubing and the expansion device.

60. The apparatus of claim 57, wherein the vibrating means is operable to avoid static friction between contacting surfaces of the tubing and the expansion device.

61. The apparatus of claim 57, wherein the vibrating means is operable to vibrate at least a major portion of at least one of the device and the tubing.

62. The apparatus of claim 57, wherein the vibrating means is operable to vibrate a selected portion of at least one of the expansion device and the tubing.

63. The apparatus of claim 57, wherein the vibrating means comprises at least one of: a movable mass; a variable fluid flow path through at least one of the expansion device and tubing; an electromagnetic oscillator; means for varying the pressure of fluid operatively associated with at least one of the device and tubing; means for creating pressure pulses in a fluid; and means for injecting a fluid into fluid operatively associated with at least one of the expansion device and the tubing.

64. The apparatus of claim 57, wherein the vibrating means is directly coupled to at least one of the expansion device and the tubing.

65. The apparatus of claim 57, wherein the vibrating means is indirectly coupled to at least one of the expansion device and the tubing.

66. The apparatus of claim 57, wherein the expansion device comprises an expansion cone.

67. The apparatus of claim 66, wherein the expansion cone is adapted for sliding contact with the tubing.

68. The apparatus of claim 66, wherein the expansion cone is adapted for rolling contact with the tubing.

69. The apparatus of claim 57, wherein the expansion device comprises a rotary expander.

70. The apparatus of claim 57, wherein the expansion device defines a fixed expansion diameter.

71. The apparatus of claim 57, wherein the expansion device comprises a variable expansion diameter.

72. The apparatus of claim 57, wherein the expansion device is compliant.

73. The apparatus of claim 57, further comprising means for creating a pressure differential across a tubing wall adjacent the expansion device.

74. The apparatus of claim 57, further comprising means for creating a varying pressure differential across a tubing wall adjacent the expansion device.

75. The apparatus of claim 57, comprising means for isolating a volume of fluid containing the expansion device.

76. The apparatus of claim 75, wherein said isolating means comprises at least one seal.

77. The apparatus of claim 76, where the seal comprises a plurality of seal members.

78. The apparatus of claim 76 or 77, wherein said seal is adapted to permit a degree of leakage thereacross.

79. Apparatus for expanding tubing, the apparatus comprising:

an expansion device; and

means for vibrating the expansion device.

80. Apparatus for expanding tubing, the apparatus comprising:

an expansion device; and

a vibration inducing device operatively associated with at least one of the tubing and the expansion device.

81. Apparatus for expanding tubing, the apparatus comprising:

an expansion device; and

a vibration inducing device operatively associated with the expansion device.

\* \* \* \* \*