



US 20240027118A1

(19) **United States**

(12) **Patent Application Publication**

Notaney et al.

(10) **Pub. No.: US 2024/0027118 A1**

(43) **Pub. Date: Jan. 25, 2024**

(54) **DEVICES FOR PRODUCING CLEAR ICE PRODUCTS AND RELATED METHODS**

**Related U.S. Application Data**

(71) Applicant: **Abstract Ice, Inc.**, Novato, CA (US)

(60) Provisional application No. 63/276,506, filed on Nov. 5, 2021, provisional application No. 63/116,453, filed on Nov. 20, 2020.

(72) Inventors: **Ashok Kumar Notaney**, San Francisco, CA (US); **Todd Stevenson**, Novato, CA (US); **Andrew James Whalen**, Windsor, CA (US); **Larry Allen Mercier, Jr.**, Ann Arbor, MI (US); **Nathan Ernst**, Dexter, MI (US); **Kristopher Schilling**, Ann Arbor, MI (US); **James Anthony Coller**, Ann Arbor, MI (US); **Jason Bazylewicz**, Ypsilanti, MI (US); **Parth Patel**, Lambertville, MI (US); **Bryce Edmund Peterson**, Hayward, CA (US)

**Publication Classification**

(51) **Int. Cl.**  
*F25C 1/18* (2006.01)  
*F25C 1/25* (2006.01)  
(52) **U.S. Cl.**  
CPC ..... *F25C 1/18* (2013.01); *F25C 1/25* (2018.01); *F25C 2400/14* (2013.01)

(21) Appl. No.: **18/253,555**

(22) PCT Filed: **Nov. 18, 2021**

(86) PCT No.: **PCT/US2021/059988**

§ 371 (c)(1),

(2) Date: **May 18, 2023**

(57) **ABSTRACT**

A device for producing an elongate ingot of clear ice comprises a housing comprising at least one flume surface wall that defines at least one elongate trough; at least one fluid intake disposed to provide a flow of liquid into the at least one elongate trough; at least one drain disposed to drain liquid from at least one elongate trough; wherein the at least a portion of the at least one flume surface wall is in thermal communication with a cooling source; and wherein the at least one fluid intake and the at least one drain are adapted to provide a constant flow of fluid to the at least one elongate trough during a freezing operation of the device. The cooling source can be an internal cooling cavity.

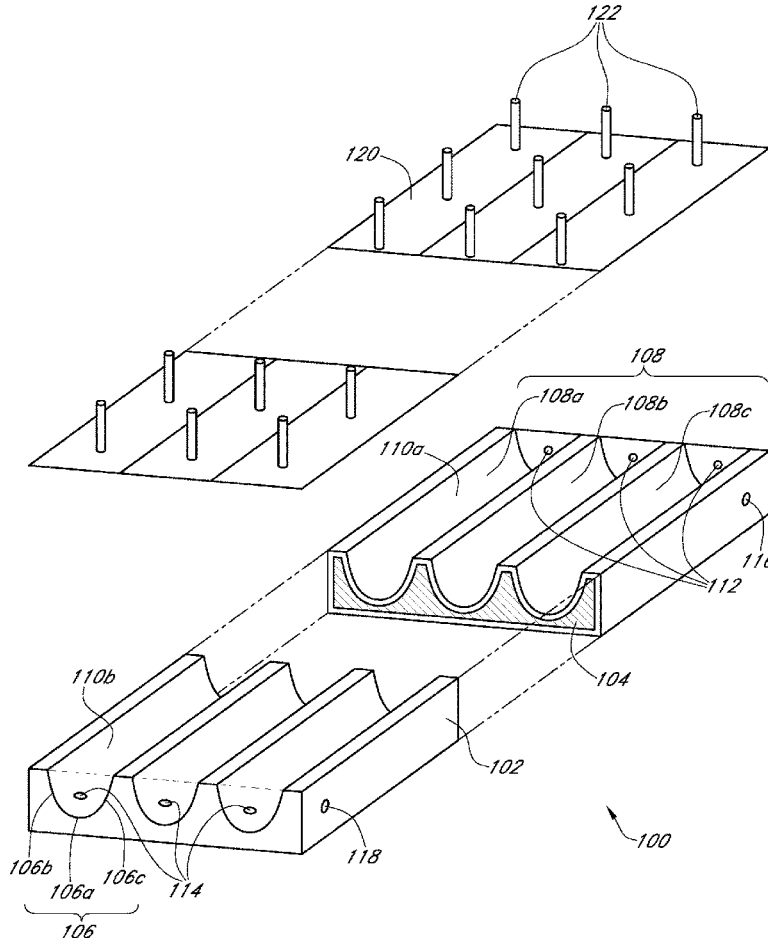

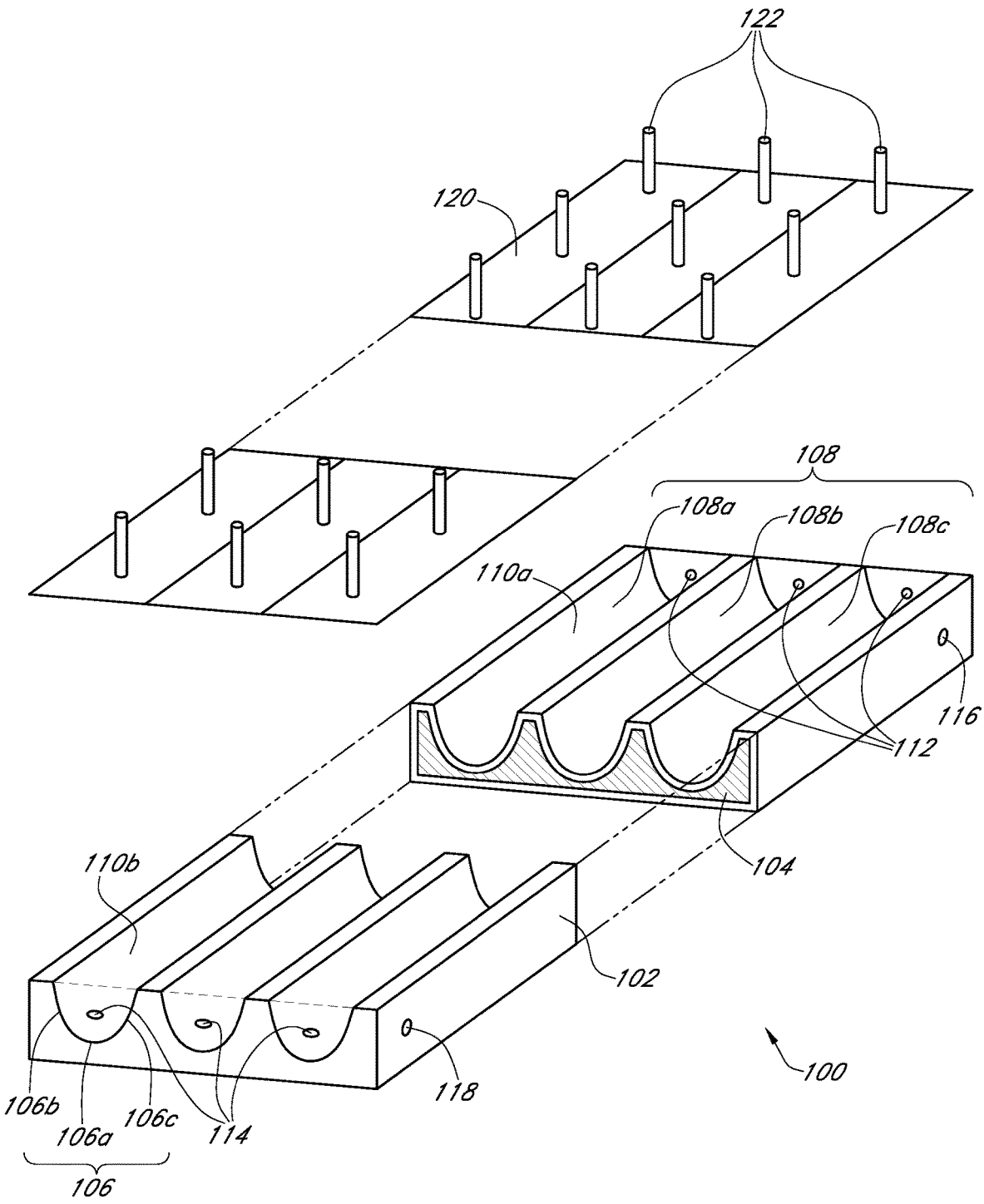

FIG. 1A

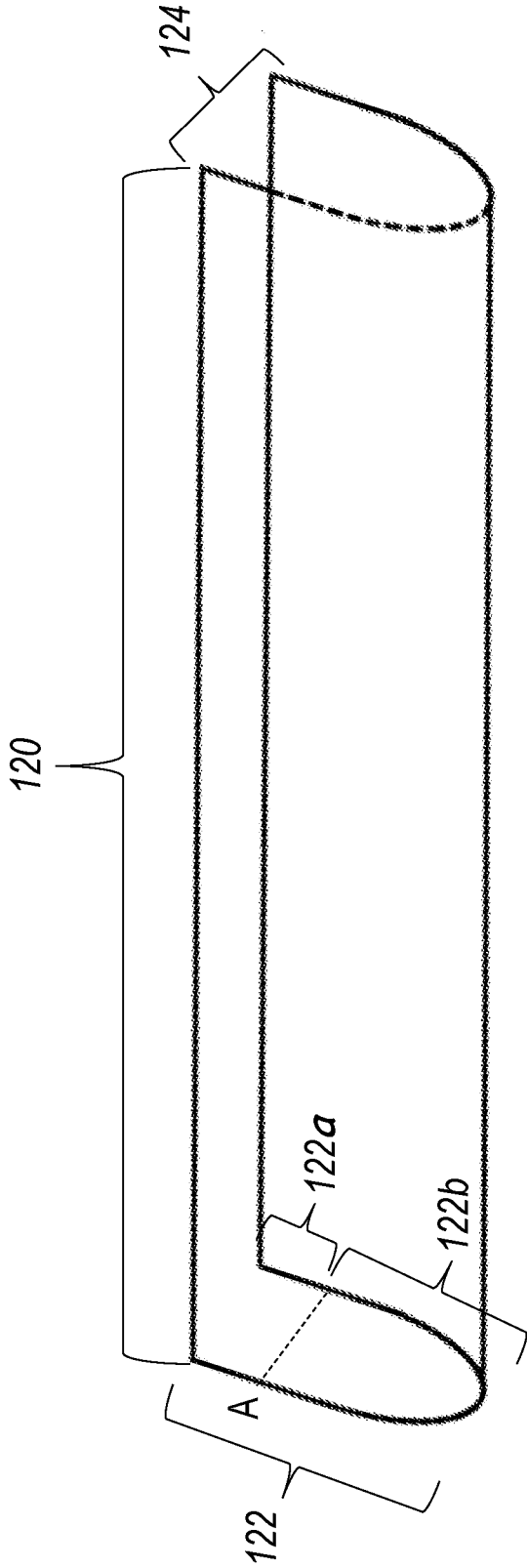

FIG. 1B

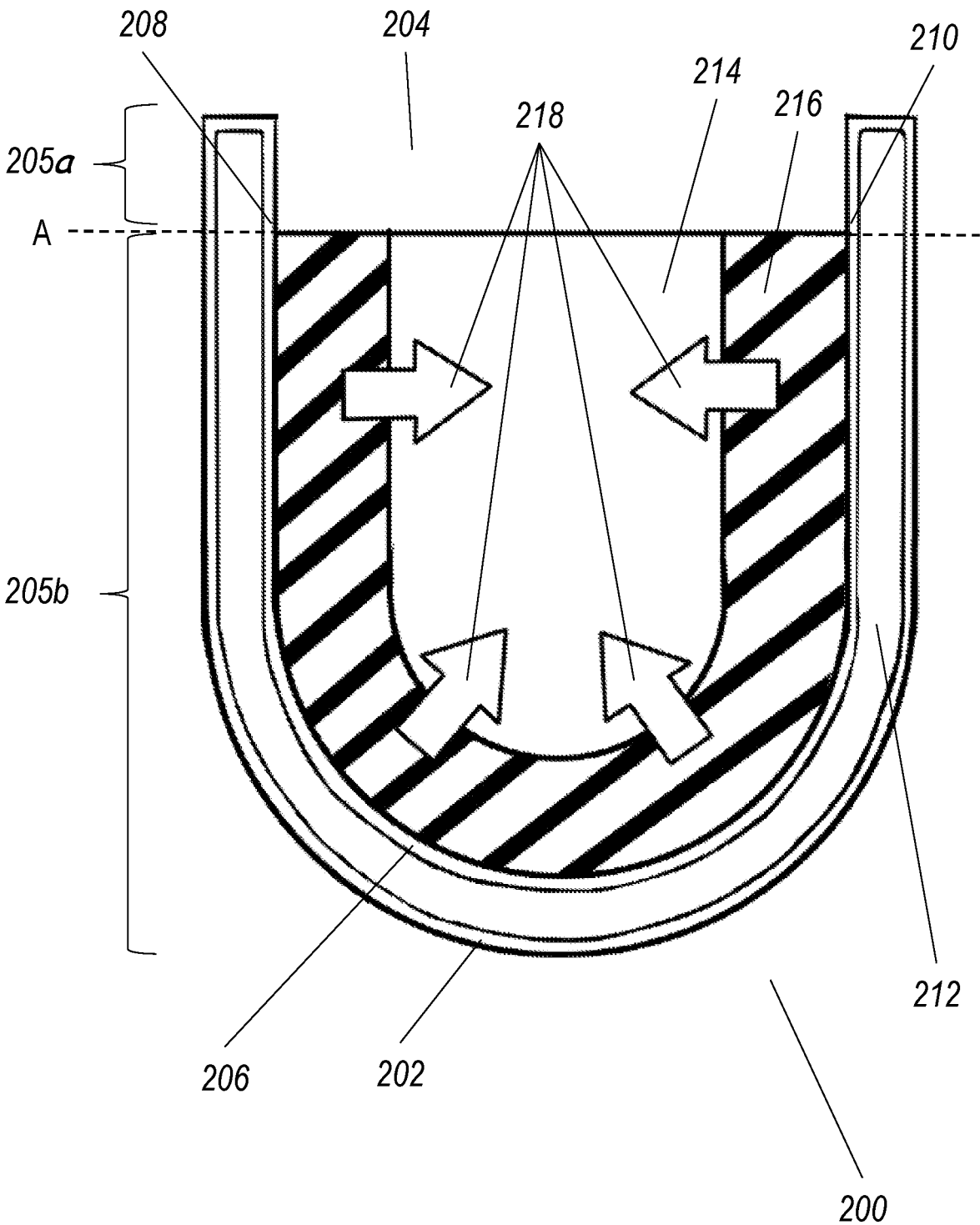

FIG. 2

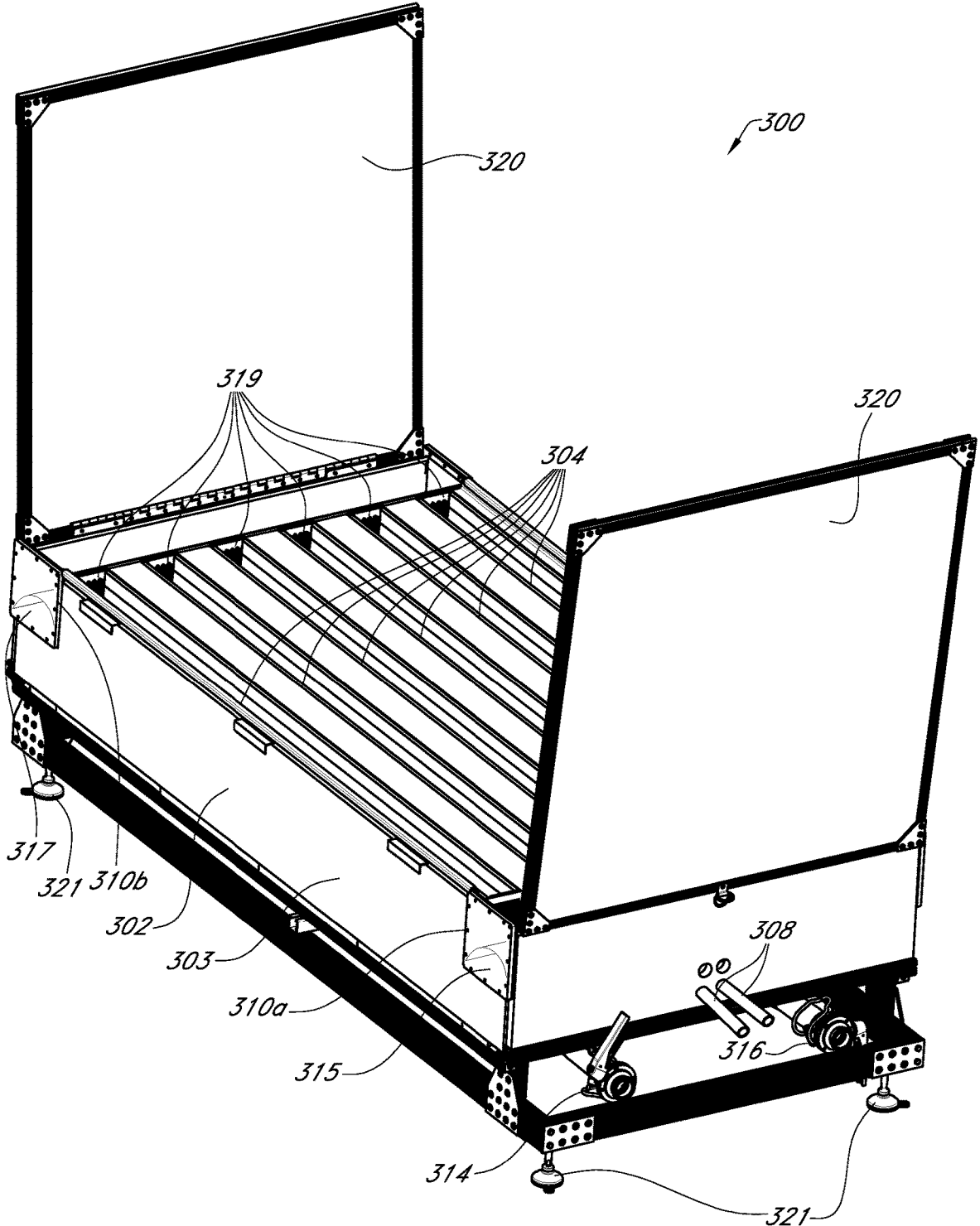

FIG. 3

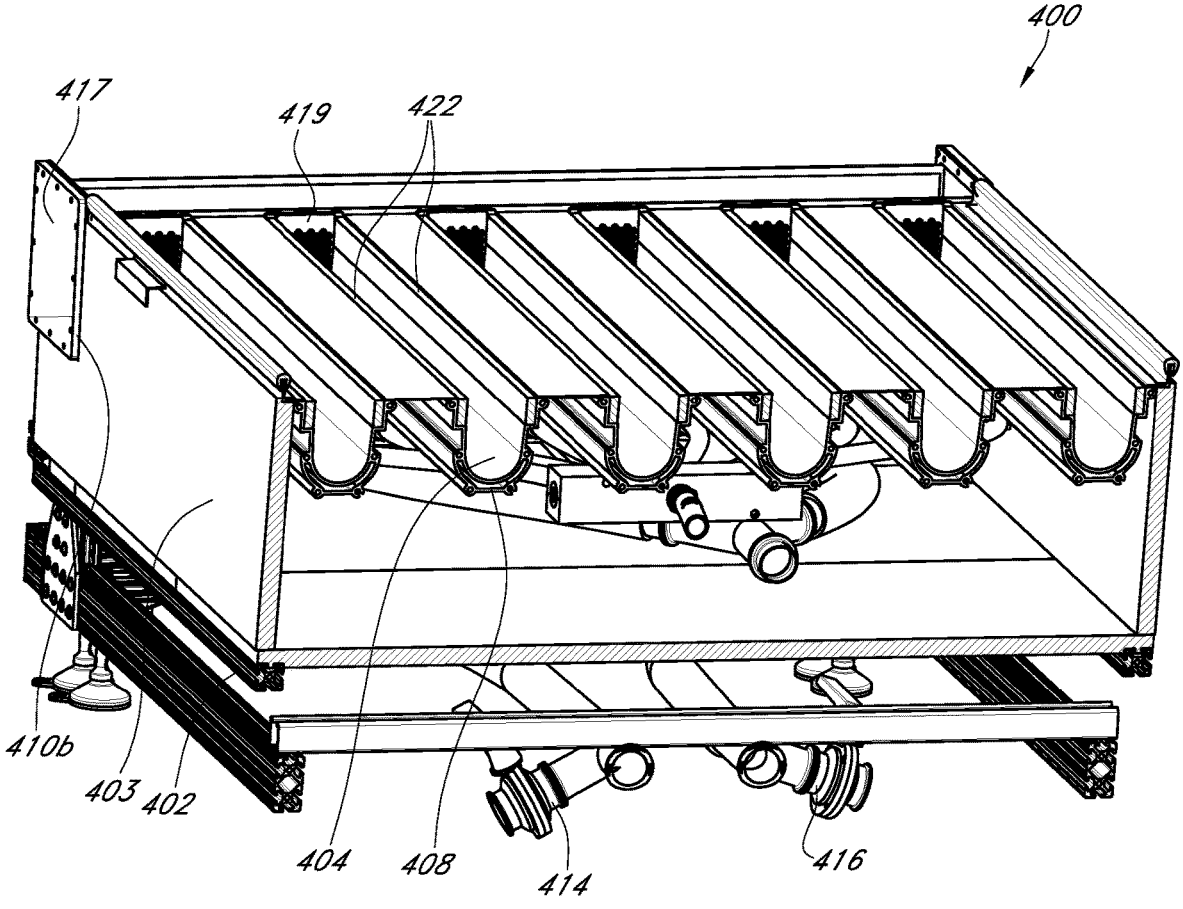

FIG. 4

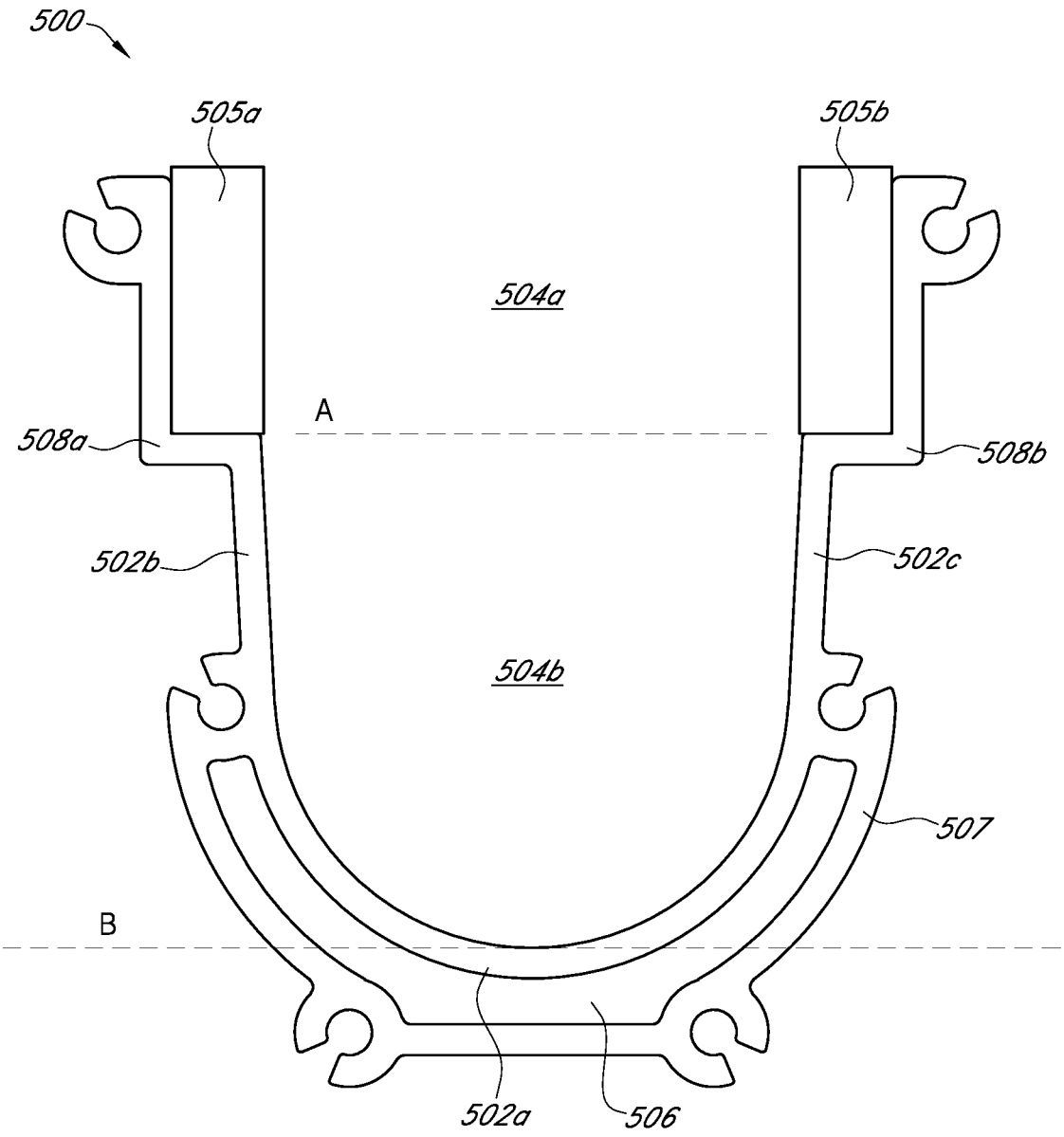

FIG. 5

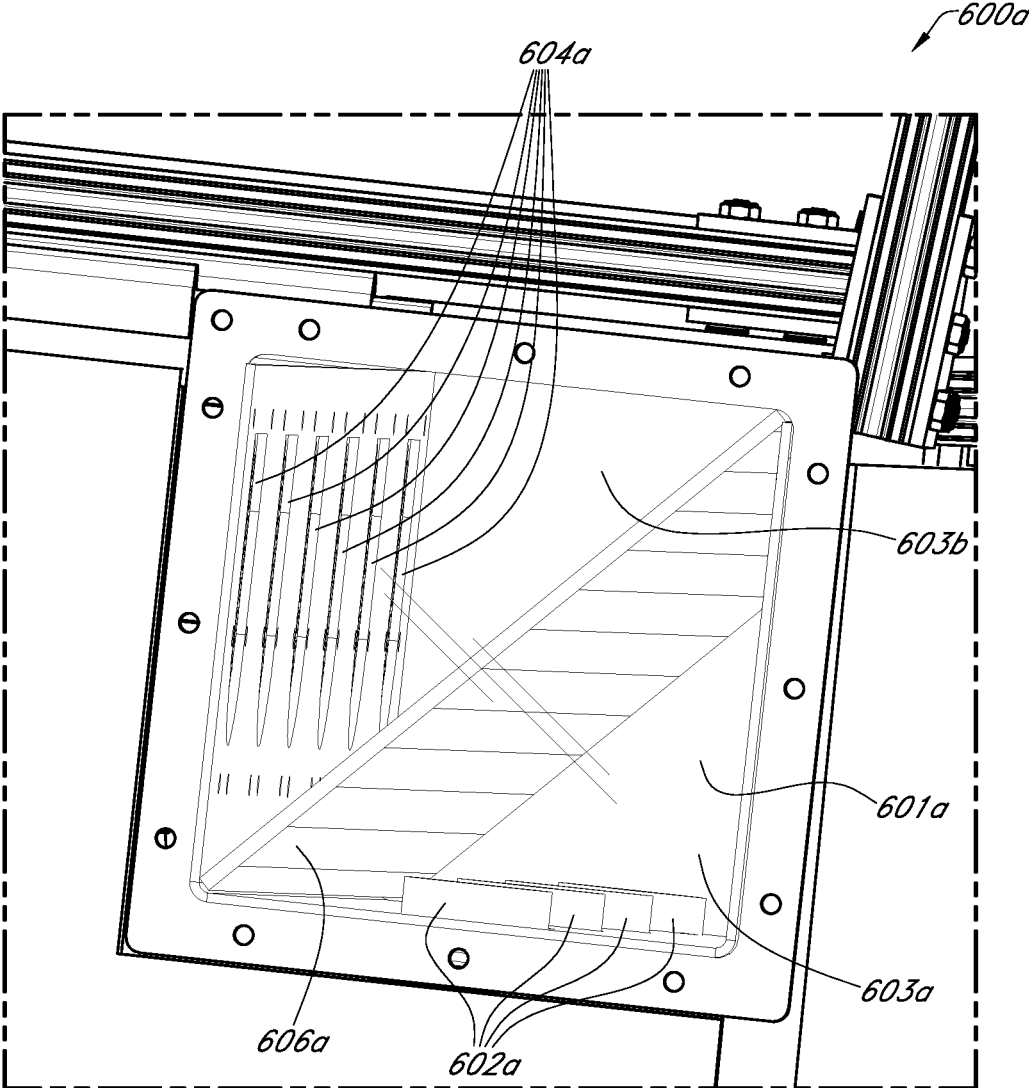

FIG. 6A



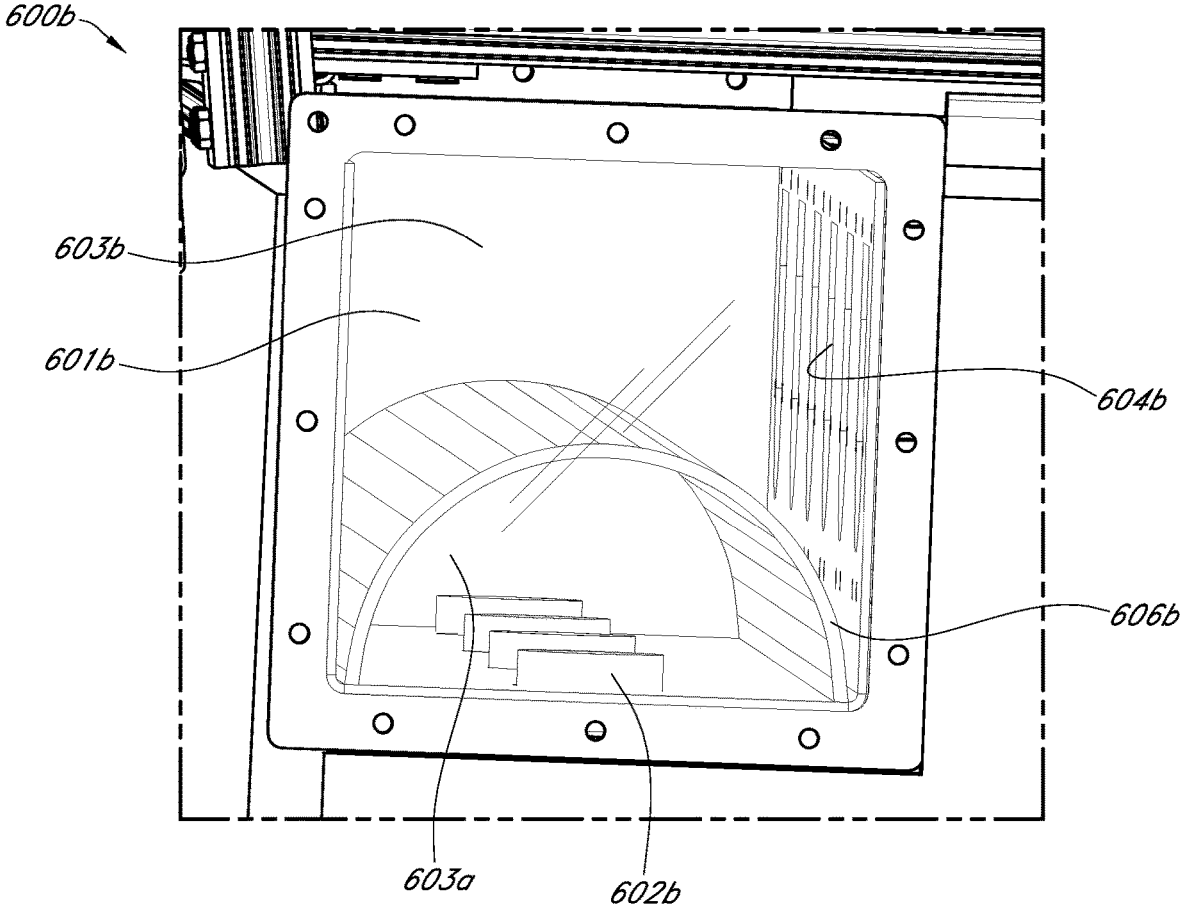

FIG. 6B

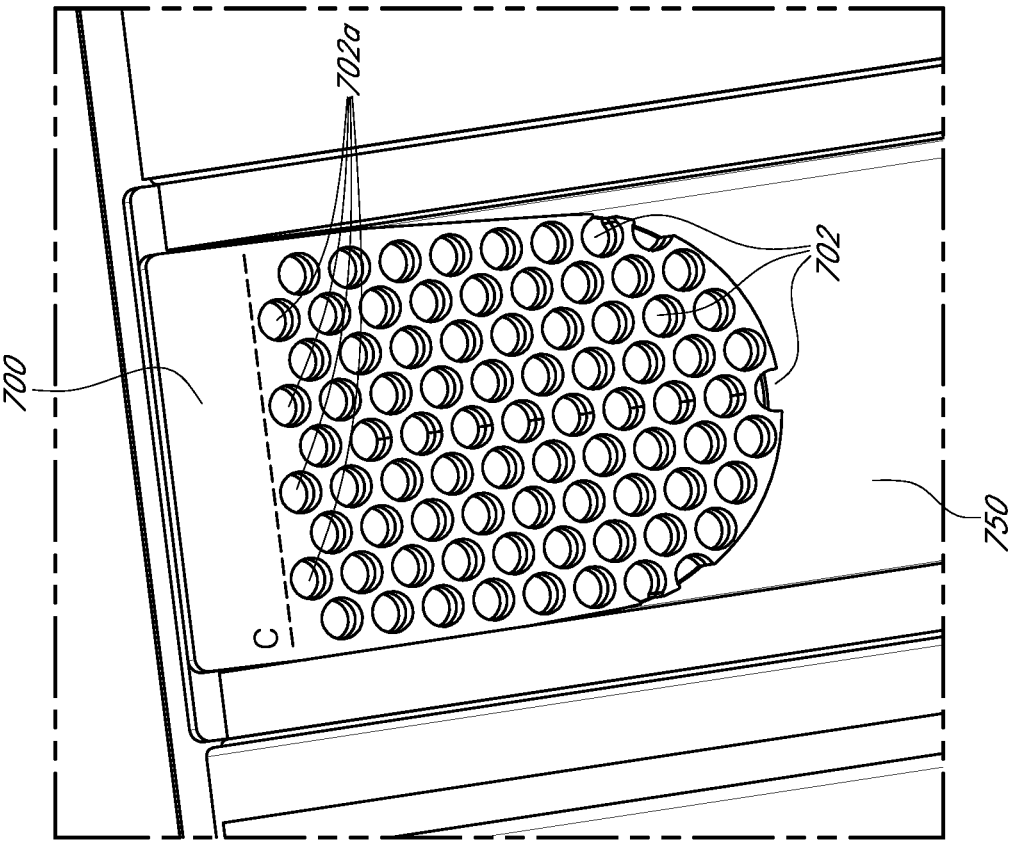

FIG. 7

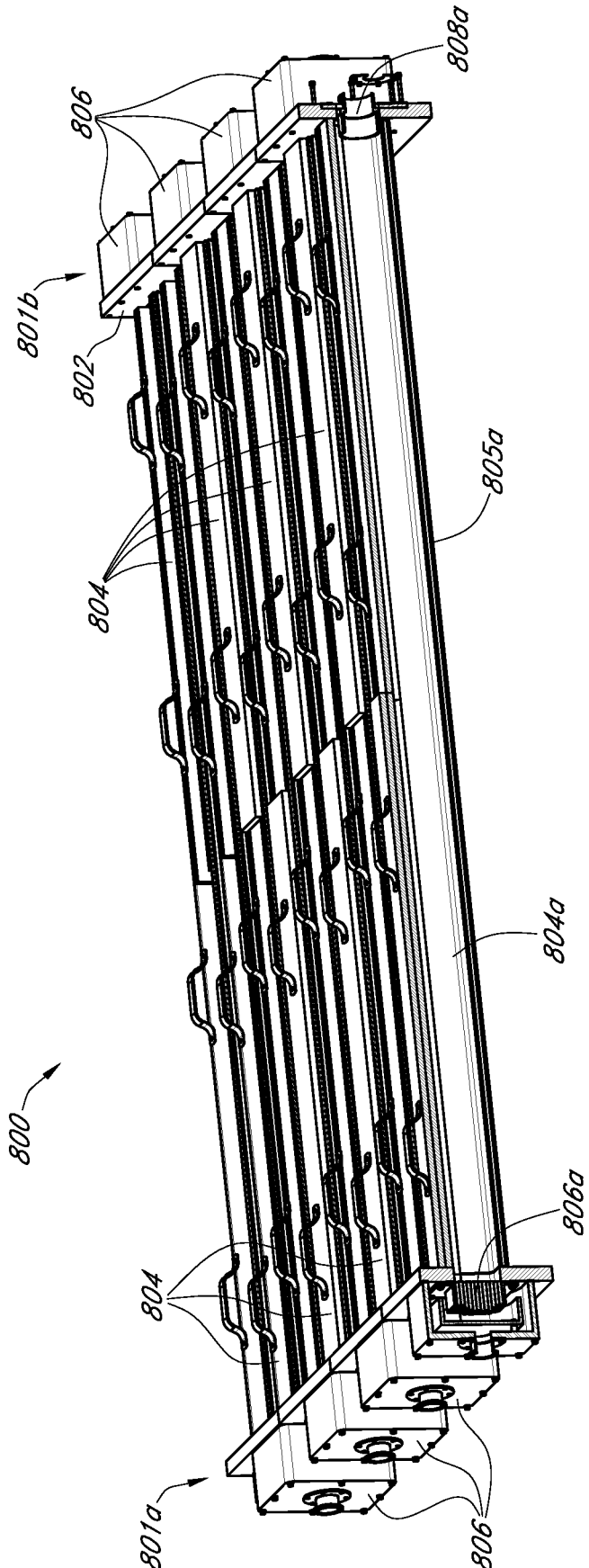

FIG. 8

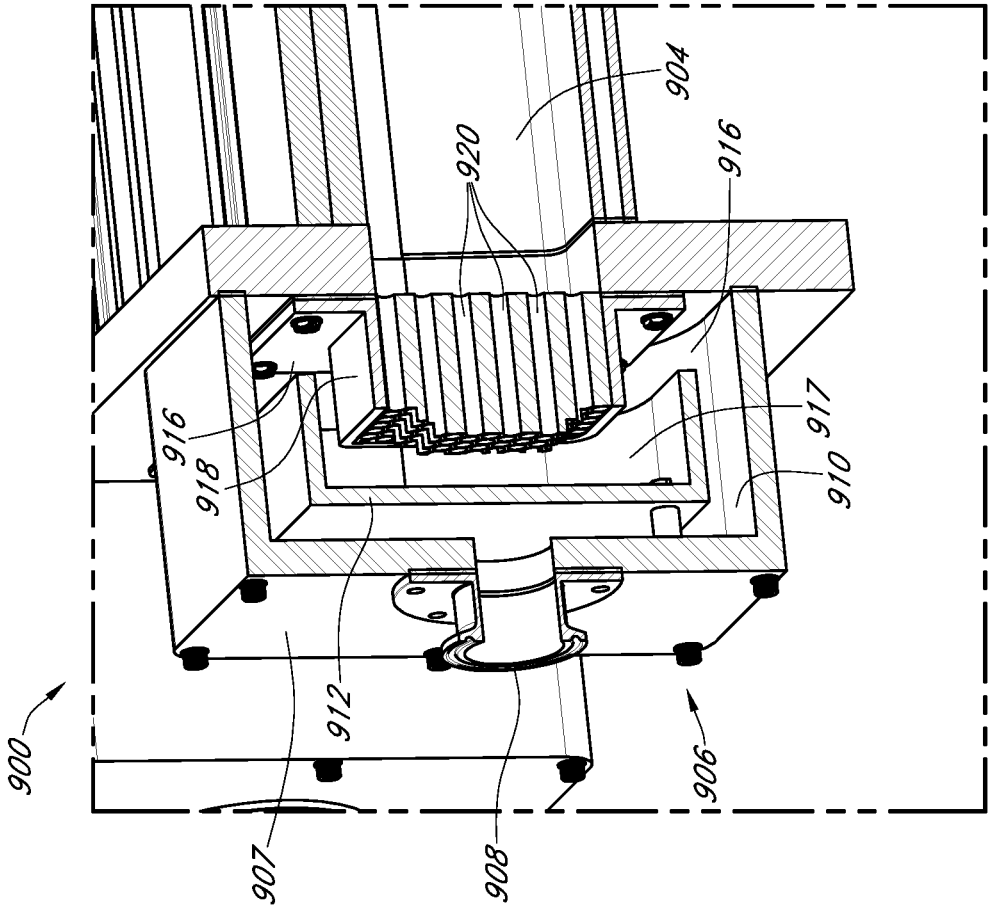

FIG. 9

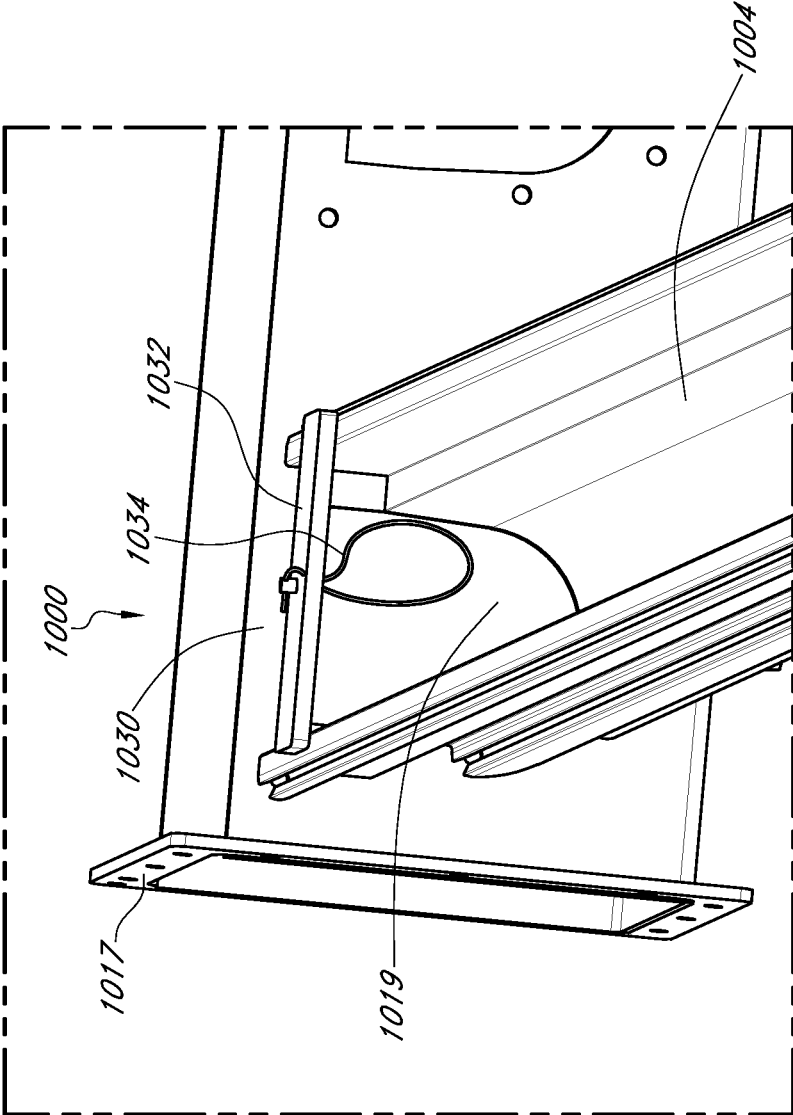

FIG. 10

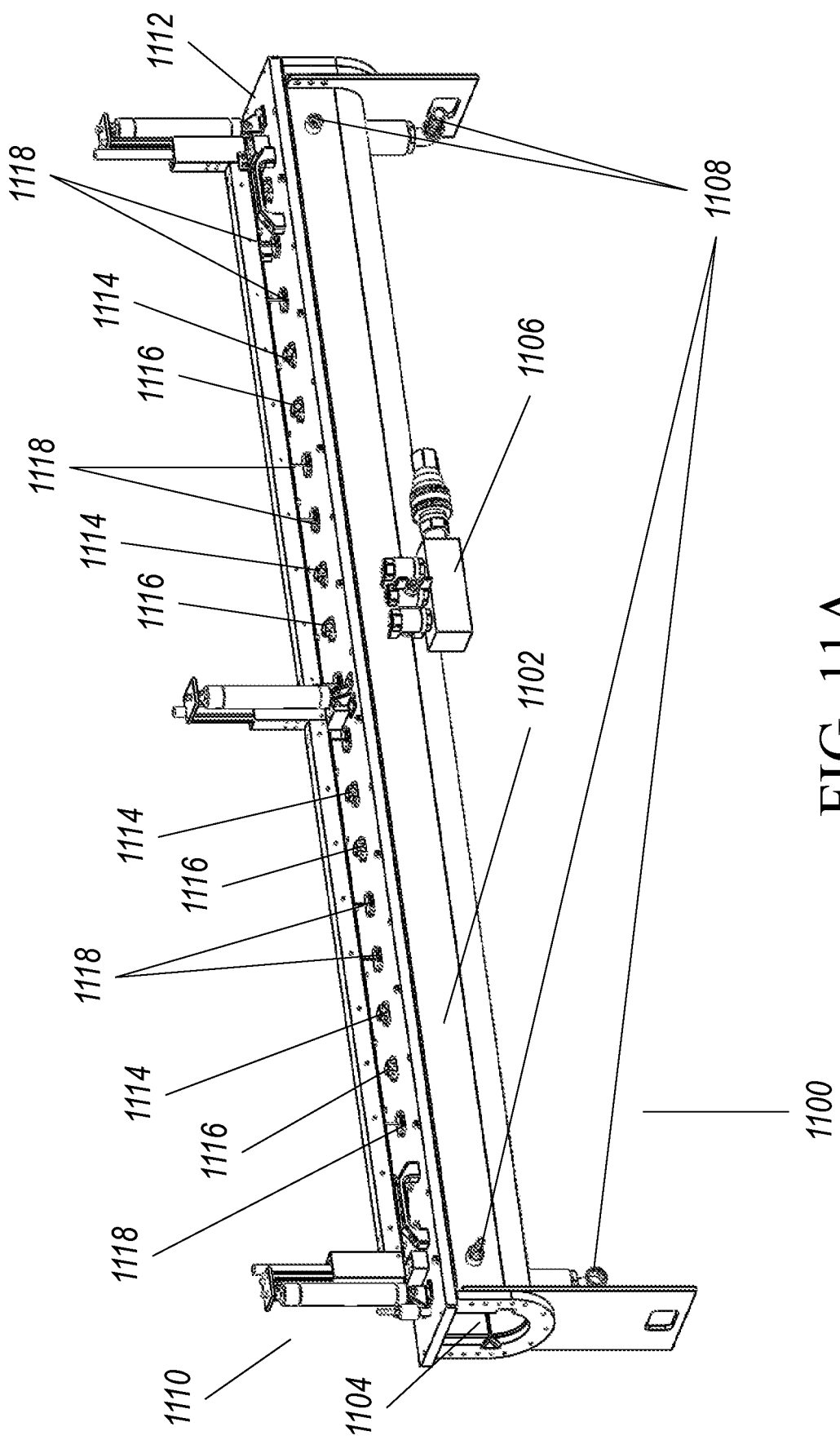

FIG. 11A

FIG. 11B

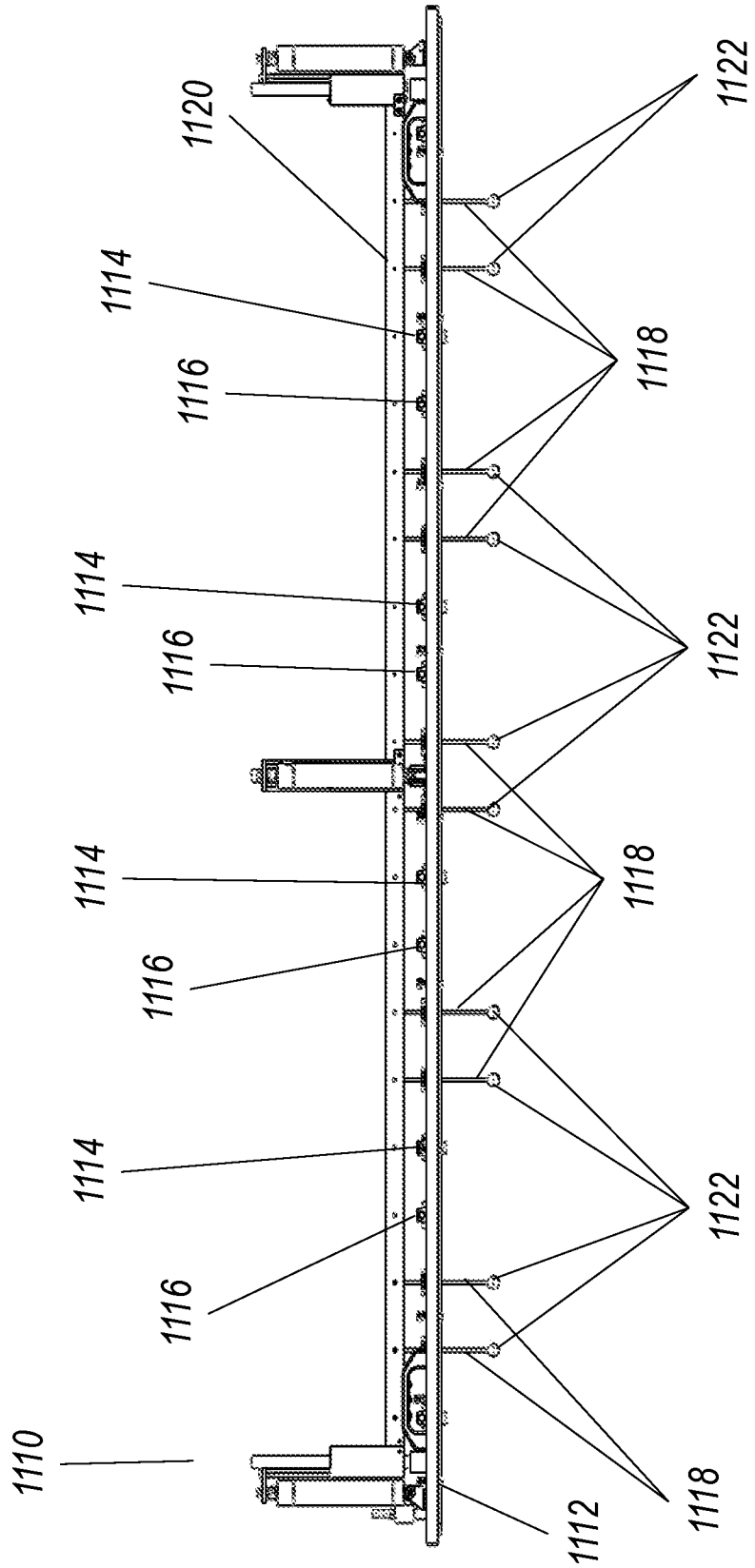
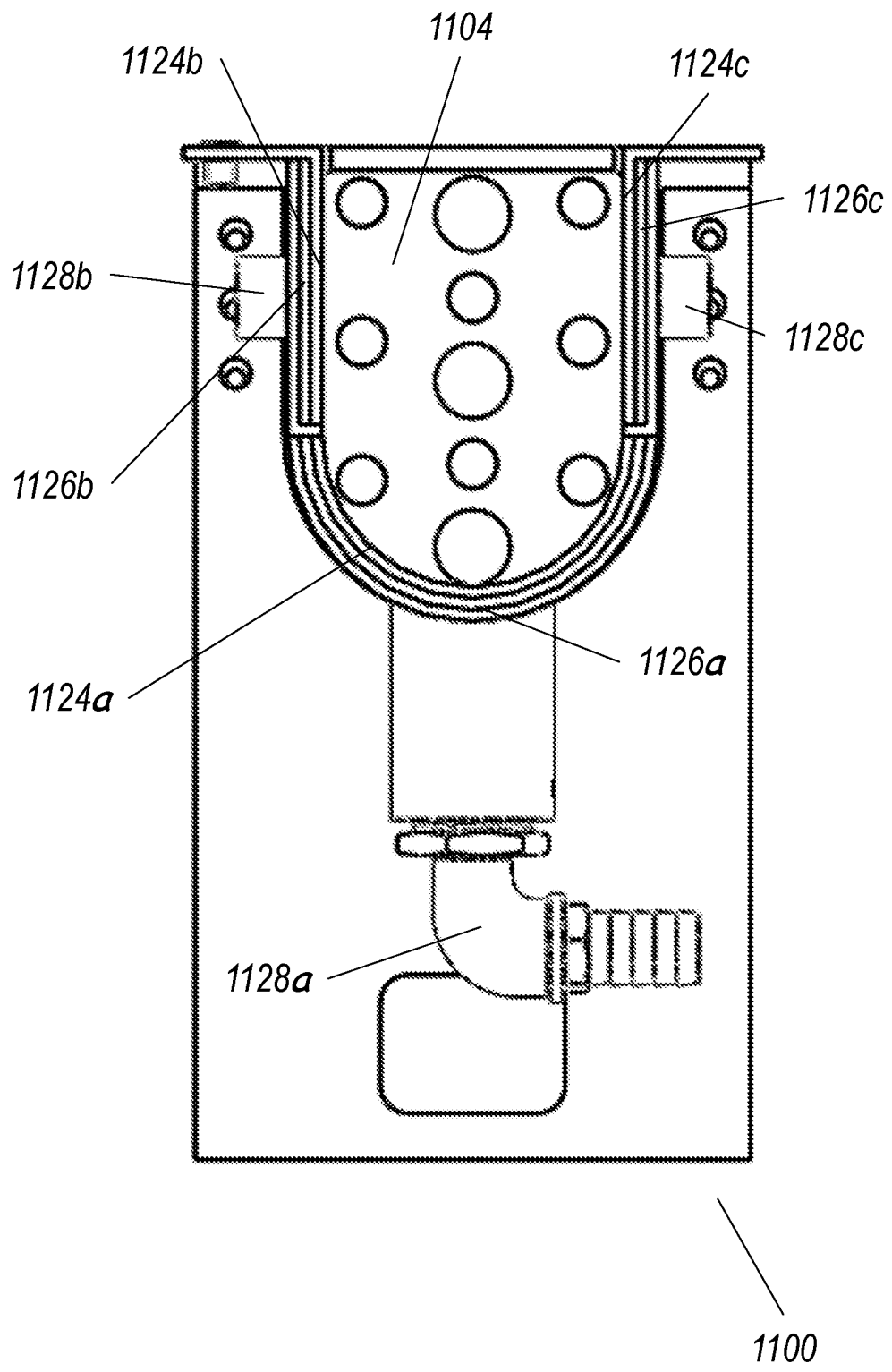

FIG. 11C





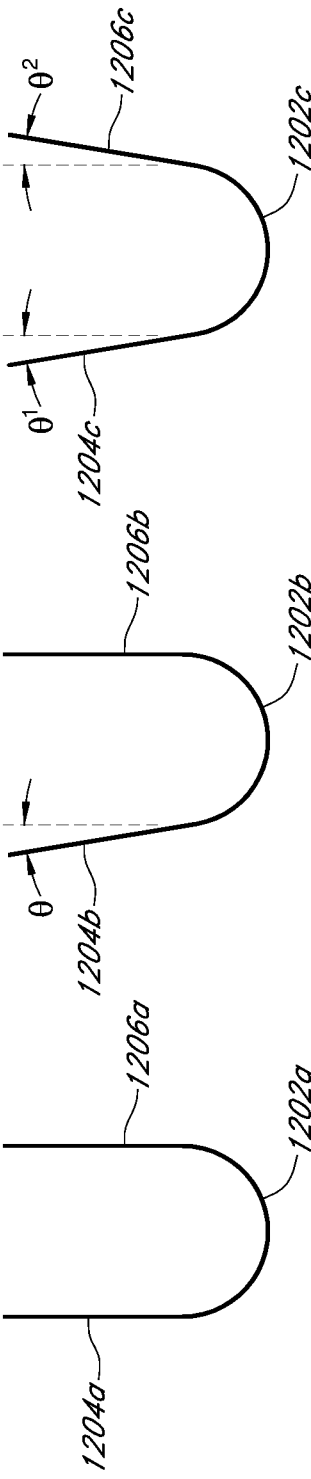

FIG. 12A      FIG. 12B      FIG. 12C

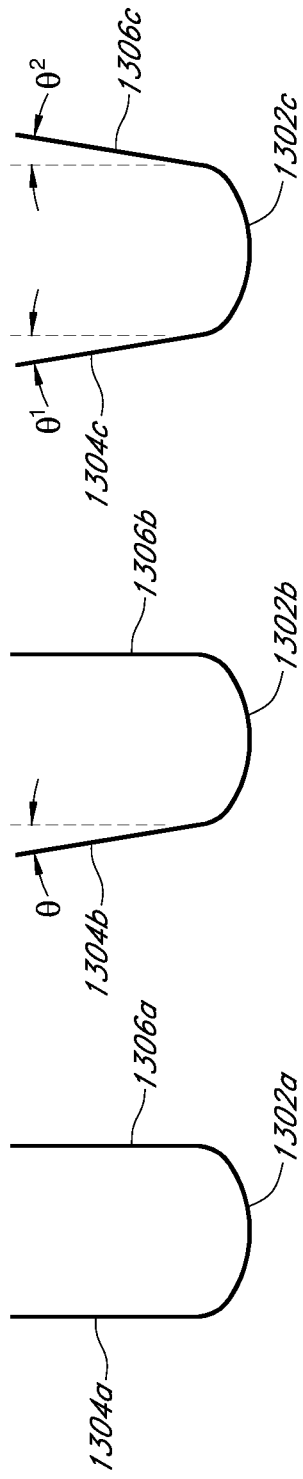

FIG. 13A

FIG. 13B

FIG. 13C

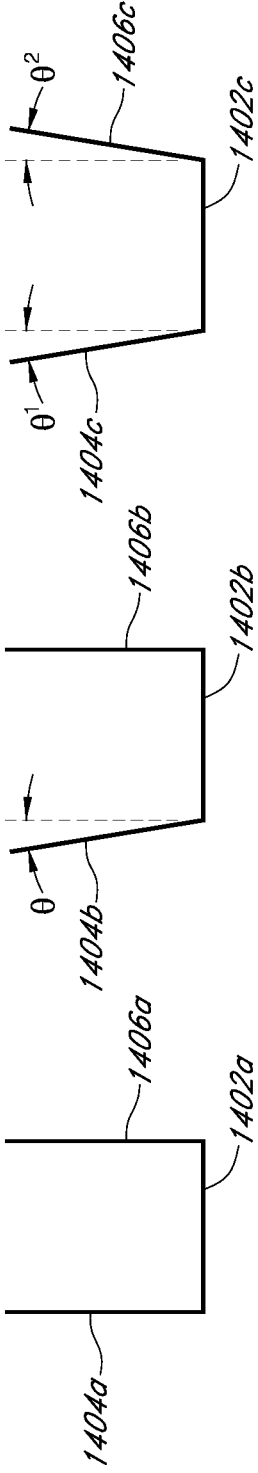

FIG. 14A FIG. 14B FIG. 14C

FIG. 15A

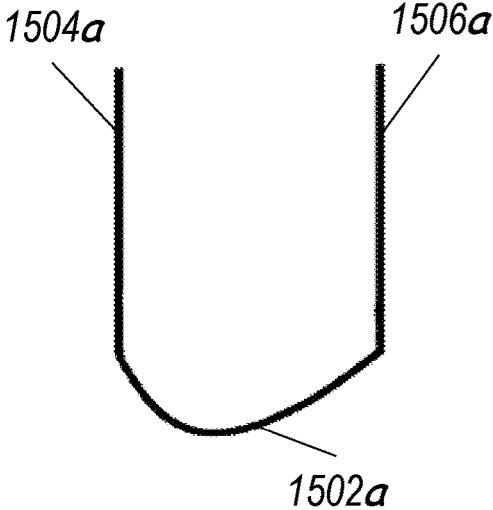

FIG. 15B

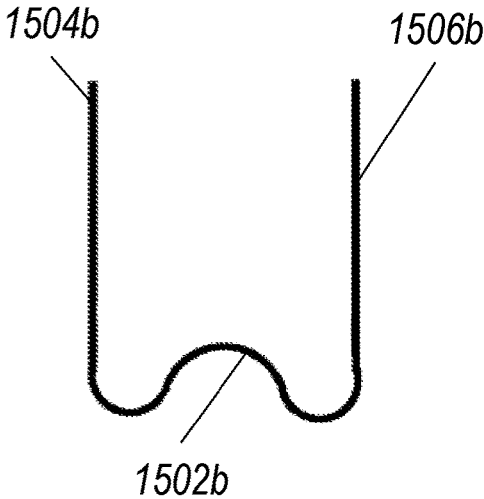

FIG. 15C

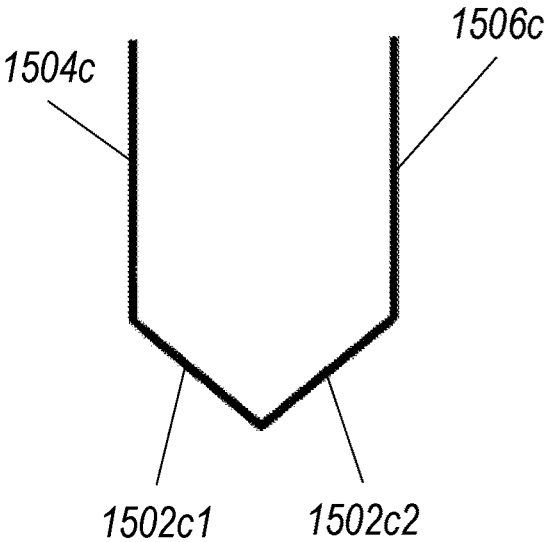
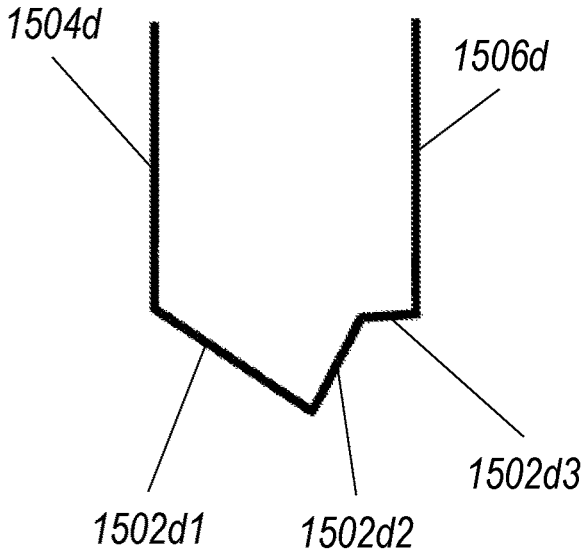

FIG. 15D



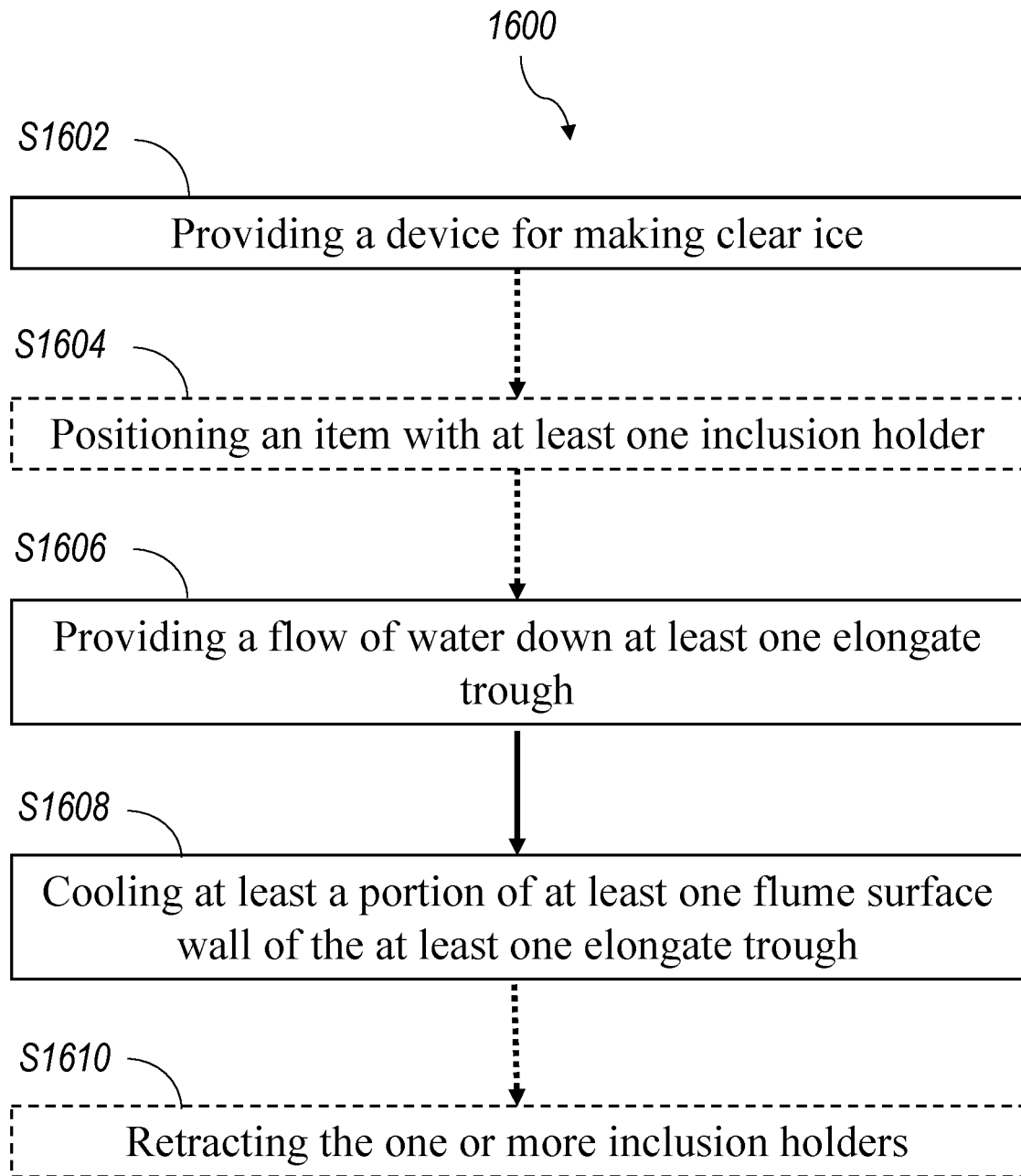

FIG. 16

Constant Varied

Step #	Time Step (min)	Total Time (min)	Flow Outer (%)	Flow Inner (%)	Flow (%)	Temp (°C)	Inclusion Utensil Retraction
1	0	0			100	-2	
2	8	8			100	-2.1	
3	6	14			100	-2.2	
4	6	20			100	-2.3	
5	5	25			100	-2.4	
6	5	30			100	-2.5	
7	5	35			100	-2.6	
8	5	40			100	-2.7	
9	5	45			100	-2.8	
10	5	50			100	-2.9	
11	5	55			100	-3	
12	5	60			100	-3.1	
13	5	65			100	-3.2	
14	5	70			100	-3.3	
15	5	75			100	-3.4	
16	5	80			100	-3.5	
17	5	85			100	-3.6	
18	5	90			100	-3.7	0
19	5	95			100	-3.8	
20	5	100			100	-3.9	
21	5	105			100	-4	
22	5	110			100	-4.1	
23	5	115			100	-4.2	
24	5	120			100	-4.3	
25	5	125			100	-4.4	
26	5	130			100	-4.5	
27	5	135			100	-4.6	
28	5	140			100	-4.7	
29	5	145			100	-4.8	
30	5	150			100	-4.9	
31	5	155			100	-5	
32	5	160			100	-5.1	
33	5	165			100	-5.2	
34	5	170			100	-5.3	
35	5	175			100	-5.4	
36	5	180			100	-5.5	
37	5	185			100	-5.6	
38	5	190			100	-5.7	
39	5	195			100	-5.8	
40	5	200			100	-5.9	
41	5	205			100	-6	
42	5	210			100	-6.1	
43	5	215			100	-6.2	
44	5	220			100	-6.3	
45	5	225			100	-6.4	
46	5	230			100	-6.5	
47	5	235			100	-6.6	
48	5	240			100	-6.7	

FIG. 17A

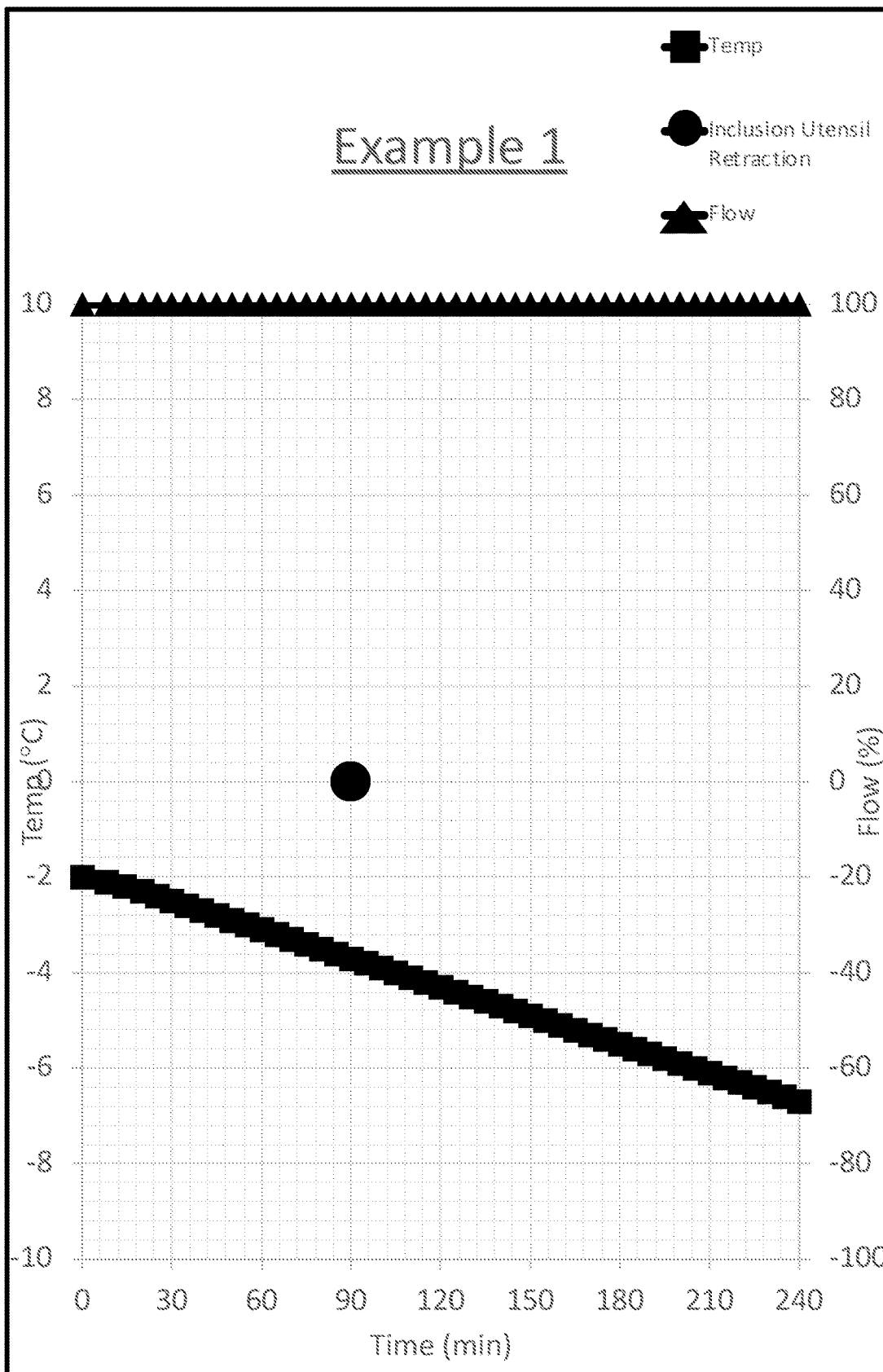

FIG. 17B

Varied Constant

Step #	Time Step (min)	Total Time (min)	Flow Outer (%)	Flow Inner (%)	Flow (%)	Temp (°C)	Inclusion Utensil Retraction
1	0	0			100	-7	
2	8	8			98	-7	
3	6	14			96	-7	
4	6	20			94	-7	
5	5	25			92	-7	
6	5	30			90	-7	
7	5	35			88	-7	
8	5	40			86	-7	
9	5	45			84	-7	
10	5	50			82	-7	
11	5	55			80	-7	
12	5	60			78	-7	
13	5	65			76	-7	
14	5	70			74	-7	
15	5	75			72	-7	
16	5	80			70	-7	
17	5	85			68	-7	
18	5	90			66	-7	
19	5	95			64	-7	
20	5	100			62	-7	
21	5	105			60	-7	
22	5	110			58	-7	
23	5	115			56	-7	
24	5	120			54	-7	0
25	5	125			52	-7	
26	5	130			50	-7	
27	5	135			48	-7	
28	5	140			46	-7	
29	5	145			44	-7	
30	5	150			42	-7	
31	5	155			40	-7	
32	5	160			38	-7	
33	5	165			36	-7	
34	5	170			34	-7	
35	5	175			32	-7	
36	5	180			30	-7	
37	5	185			28	-7	
38	5	190			26	-7	
39	5	195			24	-7	
40	5	200			22	-7	
41	5	205			20	-7	
42	5	210			18	-7	
43	5	215			16	-7	
44	5	220			14	-7	
45	5	225			12	-7	
46	5	230			10	-7	
47	5	235			8	-7	
48	5	240			6	-7	

FIG. 18A



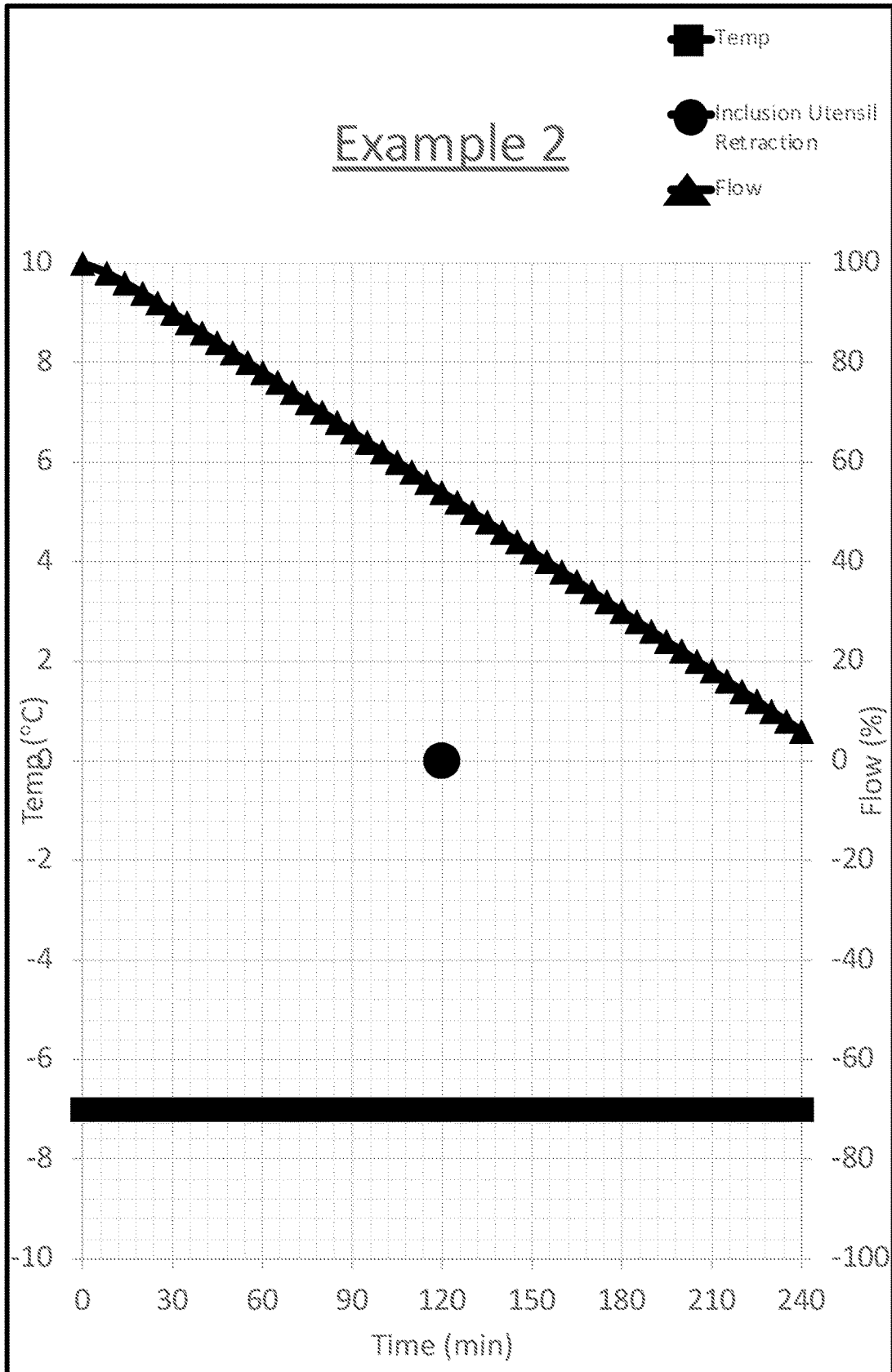

FIG. 18B

Varied Varied

Step #	Time Step (min)	Total Time (min)	Flow Outer (%)	Flow Inner (%)	Flow (%)	Temp (°C)	Inclusion Utensil Retraction
1	0	0			100	-2	
2	8	8			98	-2.1	
3	6	14			96	-2.2	
4	6	20			94	-2.3	
5	5	25			92	-2.4	
6	5	30			90	-2.5	
7	5	35			88	-2.6	
8	5	40			86	-2.7	
9	5	45			84	-2.8	
10	5	50			82	-2.9	
11	5	55			80	-3	
12	5	60			78	-3.1	
13	5	65			76	-3.2	
14	5	70			74	-3.3	
15	5	75			72	-3.4	
16	5	80			70	-3.5	
17	5	85			68	-3.6	
18	5	90			66	-3.7	
19	5	95			64	-3.8	
20	5	100			62	-3.9	
21	5	105			60	-4	
22	5	110			58	-4.1	
23	5	115			56	-4.2	
24	5	120			54	-4.3	0
25	5	125			52	-4.4	
26	5	130			50	-4.5	
27	5	135			48	-4.6	
28	5	140			46	-4.7	
29	5	145			44	-4.8	
30	5	150			42	-4.9	
31	5	155			40	-5	
32	5	160			38	-5.1	
33	5	165			36	-5.2	
34	5	170			34	-5.3	
35	5	175			32	-5.4	
36	5	180			30	-5.5	
37	5	185			28	-5.6	
38	5	190			26	-5.7	
39	5	195			24	-5.8	
40	5	200			22	-5.9	
41	5	205			20	-6	
42	5	210			18	-6.1	
43	5	215			16	-6.2	
44	5	220			14	-6.3	
45	5	225			12	-6.4	
46	5	230			10	-6.5	
47	5	235			8	-6.6	
48	5	240			6	-6.7	

FIG. 19A

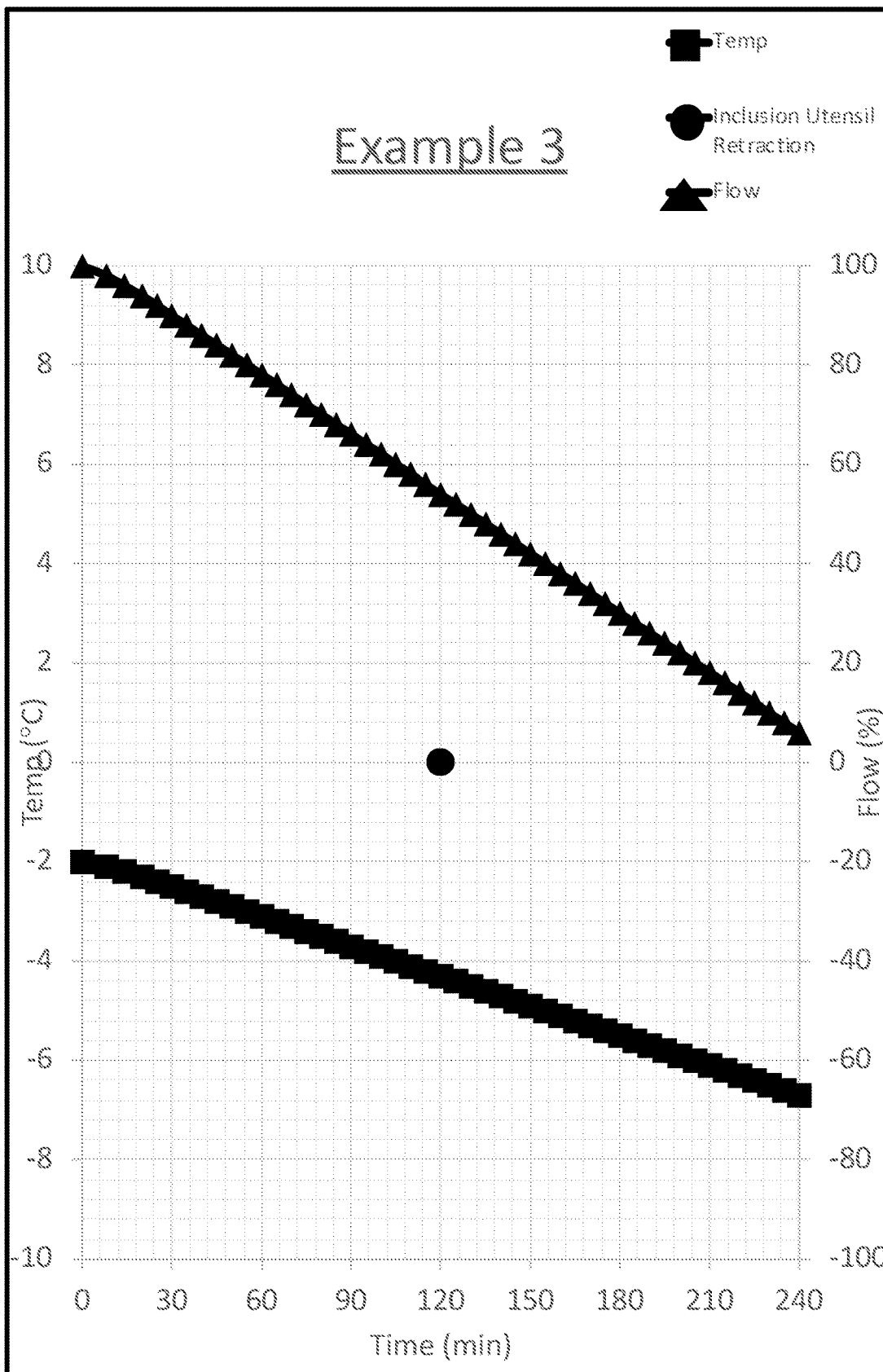

FIG. 19B

Step #	Time Step (min)	Total Time (min)	Flow Outer (%)	Flow Inner (%)	Flow (%)	Temp (°C)	Inclusion Utensil Retraction
1	0	0			100	-10	Initial cool down
2	8	8			98	-2	
3	6	14			96	-2.2	
4	6	20			94	-2.4	
5	5	25			92	-2.6	
6	5	30			90	-2.8	
7	5	35			88	-3	
8	5	40			86	-3.2	
9	5	45			84	-3.4	
10	5	50			82	-3.6	
11	5	55			80	-3.8	
12	5	60			78	-4	
13	5	65			76	-4.2	
14	5	70			74	-4.4	
15	5	75			72	-4.6	
16	5	80			70	-4.8	
17	5	85			68	-5	
18	5	90			66	-5.2	
19	5	95			64	-5.4	
20	5	100			62	-5.6	
21	5	105			60	-5.8	
22	5	110			58	-6	
23	5	115			56	-6.2	
24	5	120			54	-6.4	
25	5	125			52	-6.6	
26	5	130			50	-6.8	
27	5	135			48	-7	End plateau
28	5	140			46	-7	
29	5	145			44	-7	
30	5	150			42	-7	
31	5	155			40	-7	
32	5	160			38	-7	
33	5	165			36	-7	
34	5	170			34	-7	
35	5	175			32	-7	
36	5	180			30	-7	
37	5	185			28	-7	
38	5	190			26	-7	
39	5	195			24	-7	
40	5	200			22	-7	
41	5	205			20	-7	
42	5	210			18	-7	
43	5	215			16	-7	
44	5	220			14	-7	
45	5	225			12	-7	
46	5	230			10	-7	
47	5	235			8	-7	

FIG. 20A

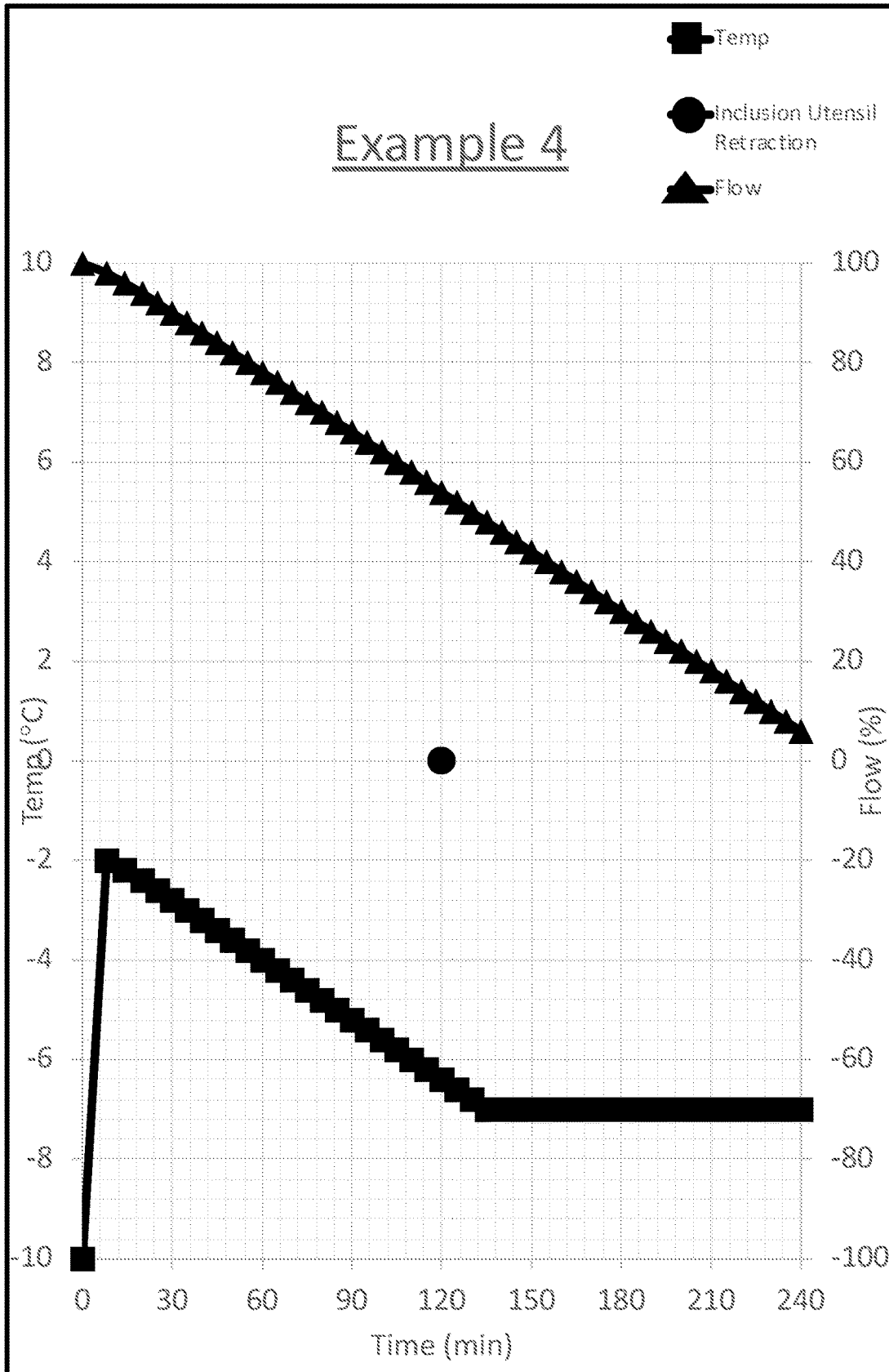

FIG. 20B

Step #	Time Step (min)	Total Time (min)	Flow Outer (%)	Flow Inner (%)	Flow (%)	Temp (°C)	Inclusion Utensil Retraction
1	0	0			100	-10	Initial cool down
2	8	8			98	-2	
3	6	14			96	-2.2	
4	6	20			94	-2.4	
5	5	25			92	-2.6	
6	5	30			90	-2.8	
7	5	35			88	-3	
8	5	40			86	-3.2	
9	5	45			84	-3.4	
10	5	50			82	-3.6	
11	5	55			80	-3.8	
12	5	60			78	-4	
13	5	65			76	-4.2	
14	5	70			74	-4.4	
15	5	75			72	-4.6	
16	5	80			70	-4.8	
17	5	85			68	-5	
18	5	90			66	-5.2	
19	5	95			64	-5.4	
20	5	100			62	-5.6	
21	5	105			60	-5.8	
22	5	110			58	-6	
23	5	115			56	-6.2	
24	5	120			54	-6.4	0
25	5	125			52	-6.6	
26	5	130			50	-6.8	
27	5	135			48	-7	End plateau
28	5	140			46	-7	
29	5	145			44	-7	
30	5	150			42	-7	
31	5	155			40	-7	
32	5	160			38	-7	
33	5	165			36	-7	
34	5	170			34	-7	
35	5	175			32	-7	
36	5	180			30	-7	
37	5	185			28	-7	
38	5	190			26	-7	
39	5	195			24	-7	
40	5	200			22	-7	
41	5	205			20	-7	
42	5	210			18	-7	
43	5	215			16	-7	
44	5	220			0	0	
45	5	225			0	0	
46	5	230			0	10	
47	5	235			0	10	
48	5	240			0	10	

FIG. 21A

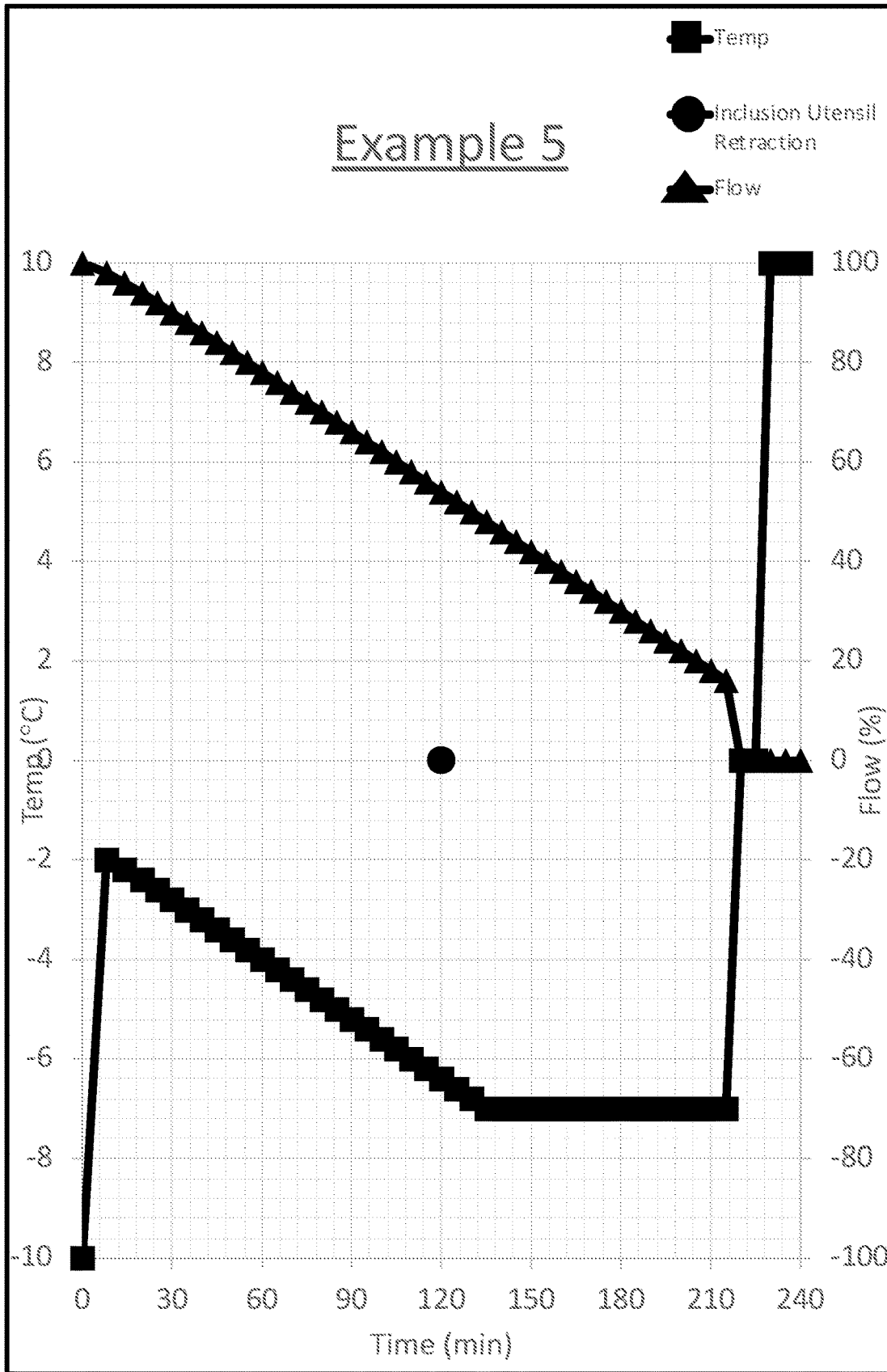

FIG. 21B

Step #	Time Step (min)	Total Time (min)	Flow Outer (%)	Flow Inner (%)	Flow (%)	Temp (°C)	Inclusion Utensil Retraction
1	0	0			100	-10	Initial cool down
2	8	8			98	-2	
3	6	14			96	-2.2	
4	6	20			94	-2.4	
5	5	25			92	-2.6	
6	5	30			90	-2.8	
7	5	35			88	-3	
8	5	40			86	-3.2	
9	5	45			84	-3.4	
10	5	50			82	-3.6	
11	5	55			80	-3.8	
12	5	60			78	-4	Mid plateau
13	5	65			76	-4	
14	5	70			74	-4	
15	5	75			72	-4	
16	5	80			70	-4	
17	5	85			68	-4	
18	5	90			66	-4	
19	5	95			64	-4	
20	5	100			62	-4	
21	5	105			60	-4.2	
22	5	110			58	-4.4	
23	5	115			56	-4.6	
24	5	120			54	-4.8	
25	5	125			52	-5	
26	5	130			50	-5.2	
27	5	135			48	-5.4	
28	5	140			46	-5.6	
29	5	145			44	-5.8	
30	5	150			42	-6	
31	5	155			40	-6.2	
32	5	160			38	-6.4	
33	5	165			36	-6.6	
34	5	170			34	-6.8	
35	5	175			32	-7	End plateau
36	5	180			30	-7	
37	5	185			28	-7	
38	5	190			26	-7	
39	5	195			24	-7	
40	5	200			22	-7	
41	5	205			20	-7	
42	5	210			18	-7	
43	5	215			16	-7	
44	5	220			0	0	Annealing
45	5	225			0	0	
46	5	230			0	10	
47	5	235			0	10	
48	5	240			0	10	

FIG. 22A



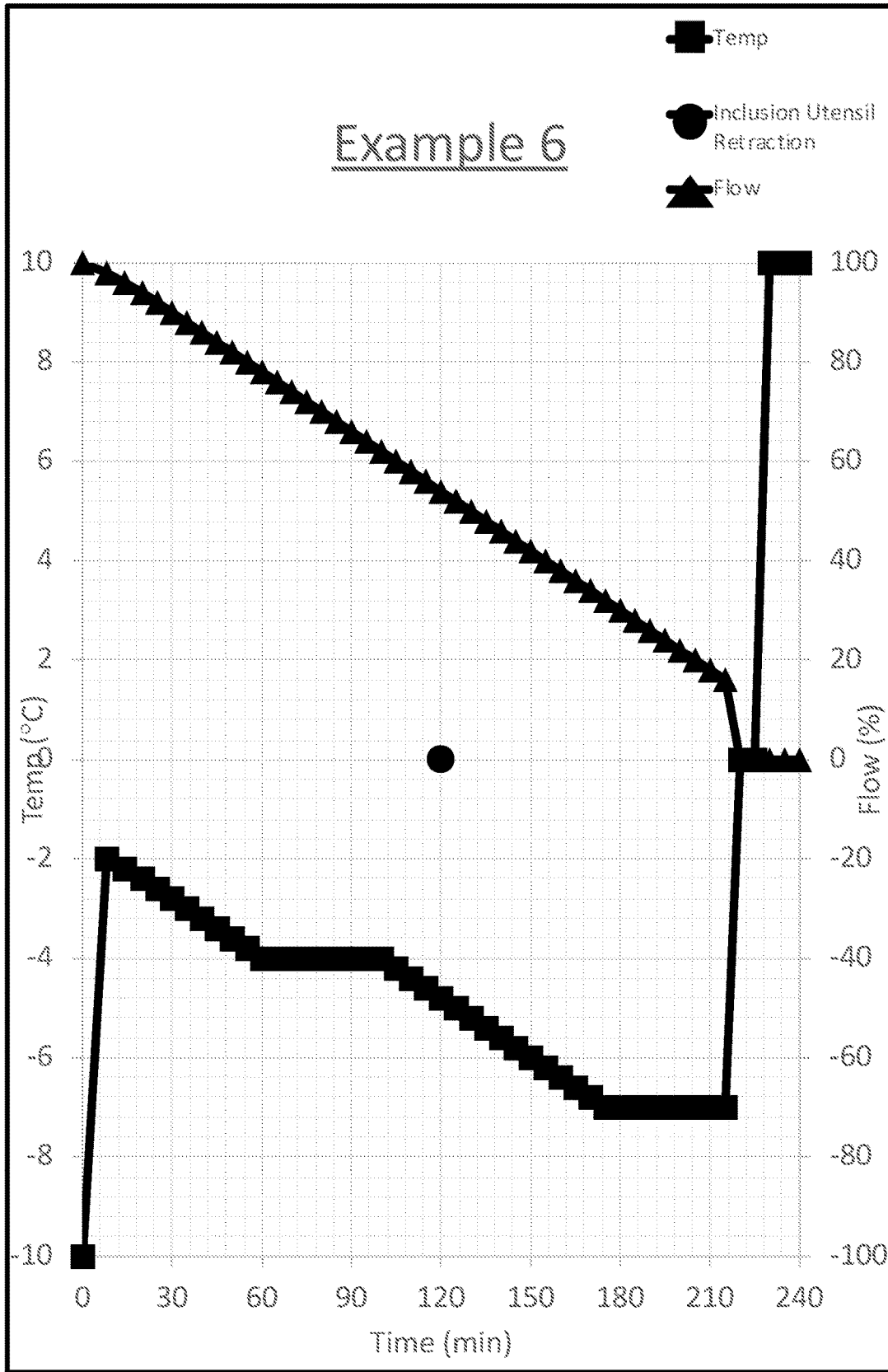

FIG. 22B

Shifts from outer to inner over time

Step #	Time Step (min)	Total Time (min)	Flow Outer (%)	Flow Inner (%)	Flow (%)	Temp (°C)	Inclusion Utensil Retraction
1	0	0	90	10	100	-10	Initial cool down
2	8	8	88	12	98	-2	
3	6	14	86	14	96	-2.2	
4	6	20	84	16	94	-2.4	
5	5	25	82	18	92	-2.6	
6	5	30	80	20	90	-2.8	
7	5	35	78	22	88	-3	
8	5	40	76	24	86	-3.2	
9	5	45	74	26	84	-3.4	
10	5	50	72	28	82	-3.6	
11	5	55	70	30	80	-3.8	
12	5	60	68	32	78	-4	Mid plateau
13	5	65	66	34	76	-4	
14	5	70	64	36	74	-4	
15	5	75	62	38	72	-4	
16	5	80	60	40	70	-4	
17	5	85	58	42	68	-4	
18	5	90	56	44	66	-4	
19	5	95	54	46	64	-4	
20	5	100	52	48	62	-4	
21	5	105	50	50	60	-4.2	
22	5	110	48	52	58	-4.4	
23	5	115	46	54	56	-4.6	
24	5	120	44	56	54	-4.8	
25	5	125	42	58	52	-5	
26	5	130	40	60	50	-5.2	
27	5	135	38	62	48	-5.4	
28	5	140	36	64	46	-5.6	
29	5	145	34	66	44	-5.8	
30	5	150	32	68	42	-6	
31	5	155	30	70	40	-6.2	
32	5	160	28	72	38	-6.4	
33	5	165	26	74	36	-6.6	
34	5	170	24	76	34	-6.8	
35	5	175	22	78	32	-7	End plateau
36	5	180	20	80	30	-7	
37	5	185	18	82	28	-7	
38	5	190	16	84	26	-7	
39	5	195	14	86	24	-7	
40	5	200	12	88	22	-7	
41	5	205	10	90	20	-7	
42	5	210	8	92	18	-7	
43	5	215	6	94	16	-7	
44	5	220	4	96	14	-7	Annealing
45	5	225	2	98	12	-7	
46	5	230	0	100	10	-7	
47	5	235			10	10	
48	5	240			10	10	

FIG. 23A

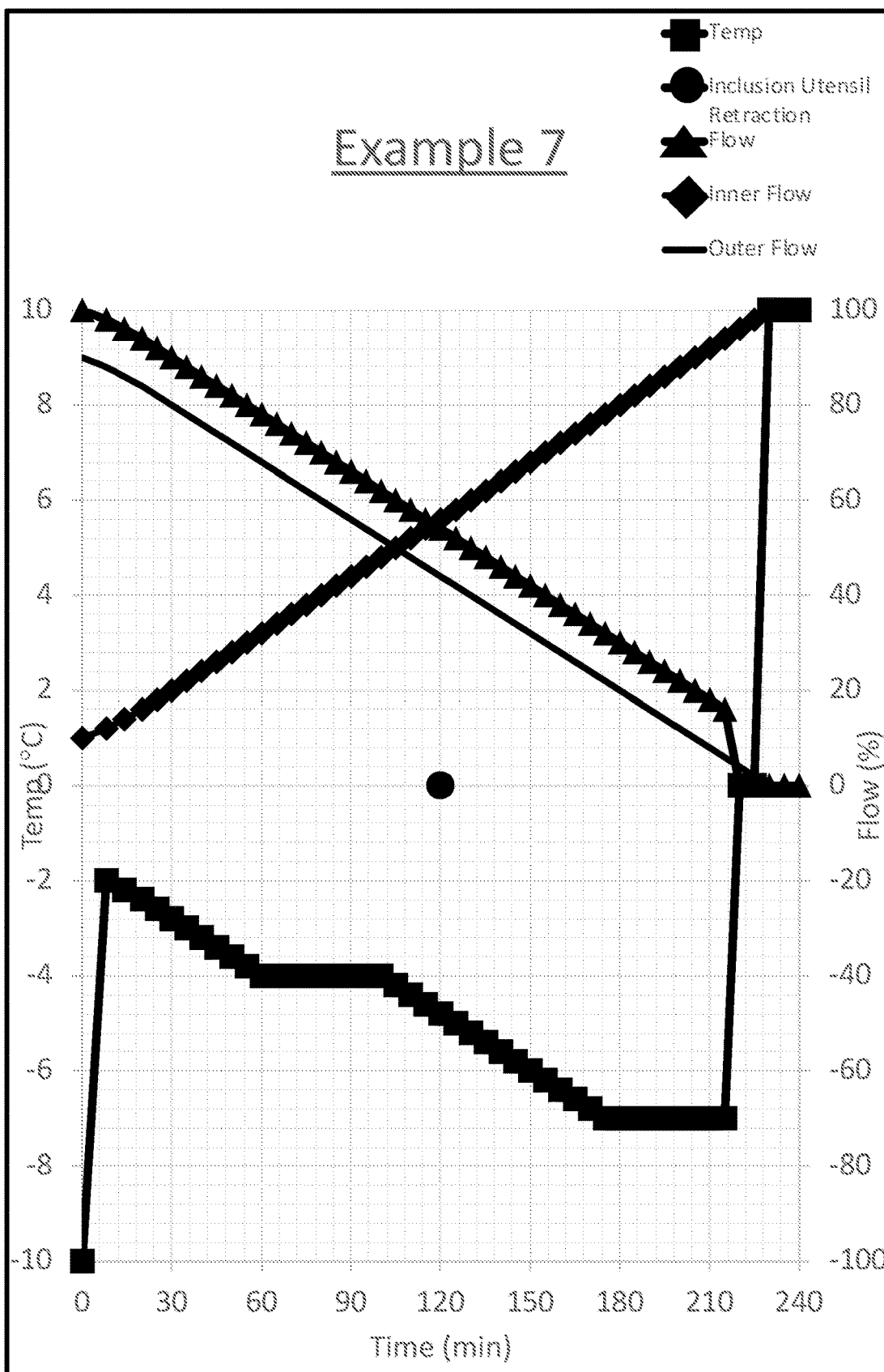

FIG. 23B

Step #	Time Step (min)	Total Time (min)	Flow Outer (%)	Flow Inner (%)	Flow (%)	Temp (°C)	Inclusion Utensil Retraction
1	0	0			100	-10	Initial cool down
2	8	8			97	-2	
3	6	14			94	-2.2	
4	6	20			91	-2.4	
5	5	25			88	-2.6	
6	5	30			85	-2.8	
7	5	35			82	-3	
8	5	40			79	-3.2	
9	5	45			76	-3.4	
10	5	50			73	-3.6	
11	5	55			70	-3.8	
12	5	60			67	-4	Mid plateau
13	5	65			64	-4	
14	5	70			61	-4	
15	5	75			58	-4	
16	5	80			55	-4	
17	5	85			52	-4	
18	5	90			49	-4	
19	5	95			46	-4	
20	5	100			43	-4	
21	5	105			40	-4.2	
22	5	110			37	-4.4	
23	5	115			34	-4.6	
24	5	120			31	-4.8	0
25	5	125			28	-5	
26	5	130			25	-5.2	
27	5	135			22	-5.4	
28	5	140			-30	-5.6	
29	5	145			-28	-5.8	
30	5	150			-26	-6	
31	5	155			-24	-6.2	
32	5	160			-22	-6.4	
33	5	165			-20	-6.6	
34	5	170			-18	-6.8	
35	5	175			-16	-7	Flow reversal
36	5	180			-14	-7	
37	5	185			-12	-7	
38	5	190			-10	-7	
39	5	195			-8	-7	
40	5	200			-6	-7	End plateau
41	5	205			-4	-7	
42	5	210			-2	-7	
43	5	215			0	-7	
44	5	220			0	0	
45	5	225			0	0	
46	5	230			0	10	Annealing
47	5	235			0	10	
48	5	240			0	10	

FIG. 24A

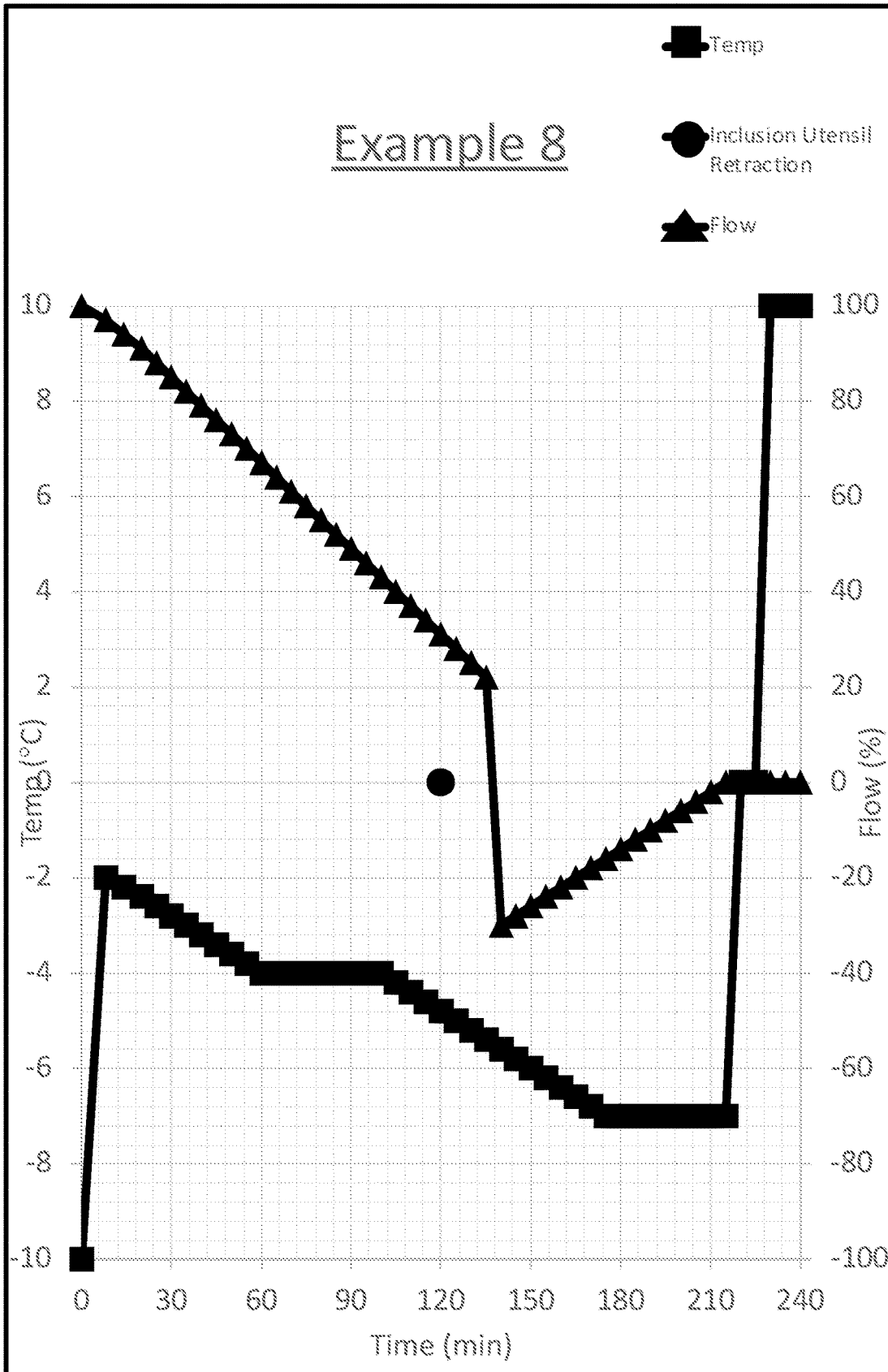

FIG. 24B

Shifts from outer to inner over time

Step #	Time Step (min)	Total Time (min)	Flow Outer (%)	Flow Inner (%)	Flow (%)	Temp (°C)	Inclusion Utensil Retraction
1	0	0	90	10	100	-10	Initial cool down
2	8	8	88	12	97	-2	
3	6	14	86	14	94	-2.2	
4	6	20	84	16	91	-2.4	
5	5	25	82	18	88	-2.6	
6	5	30	80	20	85	-2.8	
7	5	35	78	22	82	-3	
8	5	40	76	24	79	-3.2	
9	5	45	74	26	76	-3.4	
10	5	50	72	28	73	-3.6	
11	5	55	70	30	70	-3.8	
12	5	60	68	32	67	-4	Mid plateau
13	5	65	66	34	64	-4	
14	5	70	64	36	61	-4	
15	5	75	62	38	58	-4	
16	5	80	60	40	55	-4	
17	5	85	58	42	52	-4	
18	5	90	56	44	49	-4	
19	5	95	54	46	46	-4	
20	5	100	52	48	43	-4	
21	5	105	50	50	40	-4.2	
22	5	110	50	50	37	-4.4	
23	5	115	50	50	34	-4.6	
24	5	120	50	50	31	-4.8	
25	5	125	50	50	28	-5	
26	5	130	50	50	25	-5.2	
27	5	135	0	100	-33	-5.4	
28	5	140	0	100	-30	-5.6	
29	5	145	0	100	-28	-5.8	
30	5	150	0	100	-26	-6	
31	5	155	0	100	-24	-6.2	
32	5	160	0	100	-22	-6.4	
33	5	165	0	100	-20	-6.6	
34	5	170	0	100	-18	-6.8	
35	5	175	0	100	-16	-7	End plateau
36	5	180	0	100	-14	-7	
37	5	185	0	100	-12	-7	
38	5	190	0	100	-10	-7	
39	5	195	0	100	-8	-7	
40	5	200	0	100	-6	-7	
41	5	205	0	100	-4	-7	
42	5	210	0	100	-2	-7	
43	5	215	0	100	0	-7	
44	5	220	0	100	0	0	Annealing
45	5	225	0	100	0	0	
46	5	230	0	100	0	10	
47	5	235	0	100	0	10	
48	5	240	0	100	0	10	

FIG. 25A

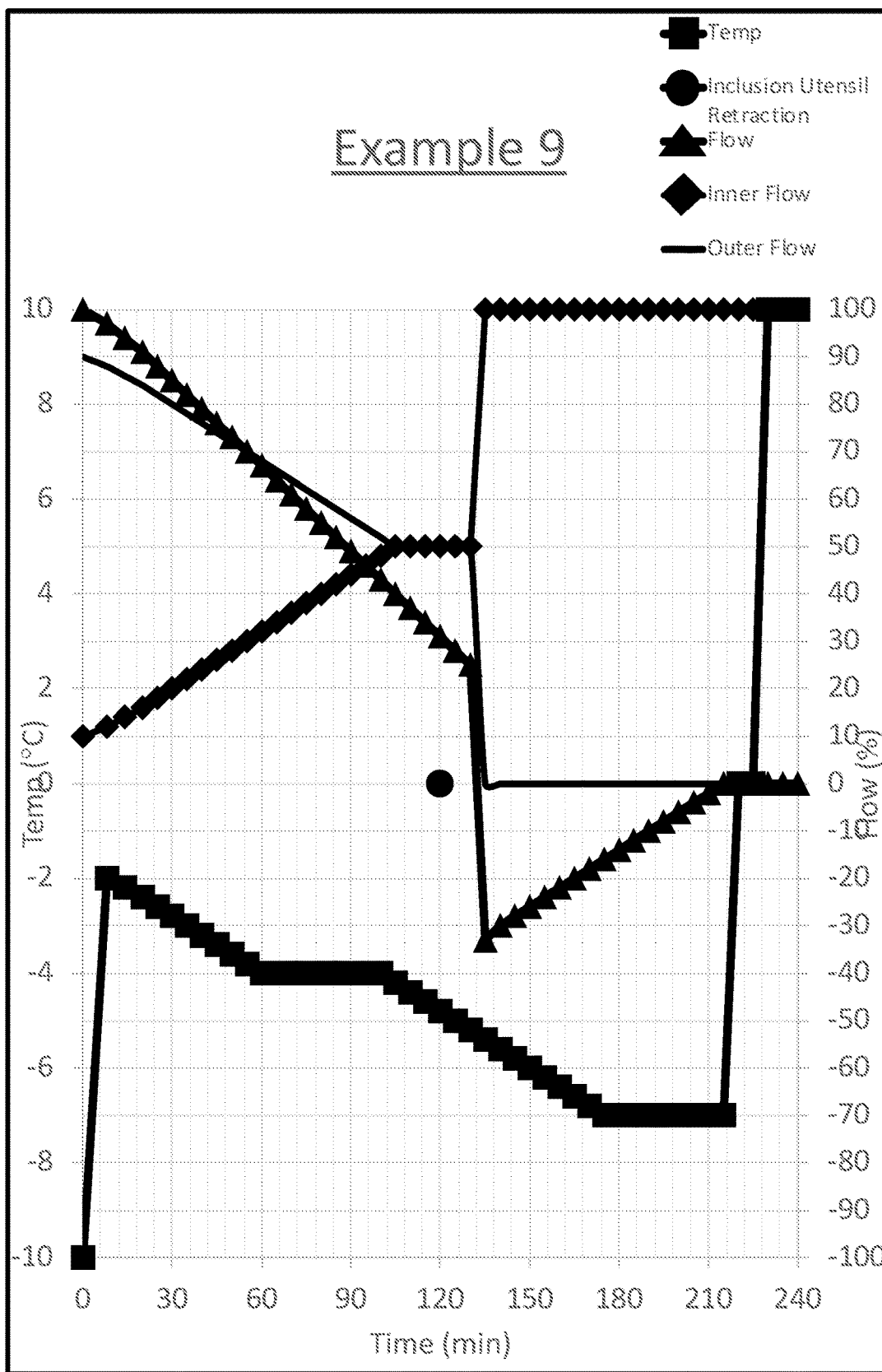

FIG. 25B

Table 1

Height from bottom (mm)	3° Round shape w/vertical sides			3° Round shape with 8.5-degree sides			3° Round shape with 1.16-degree sides			3° Round shape with 2-degree sides			3° Round shape with 1-degree sides		
	W	I	0	W	I	0	W	I	0	W	I	0	W	I	0
0.0	0.00	0.00	0	0.00	0.00	0	0.00	0.00	0	0.00	0.00	0	0.00	0.00	0
5.0	18.87	18.87	1,189	18.87	18.87	1,189	18.87	18.87	1,189	18.87	18.87	1,189	18.87	18.87	1,189
10.0	25.73	25.73	2,211	25.73	25.73	2,211	25.73	25.73	2,211	25.73	25.73	2,211	25.73	25.73	2,211
15.0	30.30	30.30	3,066	30.30	30.30	3,066	30.30	30.30	3,066	30.30	30.30	3,066	30.30	30.30	3,066
20.0	33.53	33.53	3,754	33.53	33.53	3,754	33.53	33.53	3,754	33.53	33.53	3,754	33.53	33.53	3,754
25.0	35.78	35.78	4,275	35.78	35.78	4,275	35.78	35.78	4,275	35.78	35.78	4,275	35.78	35.78	4,275
30.0	37.23	37.23	4,629	37.23	37.23	4,629	37.23	37.23	4,629	37.23	37.23	4,629	37.23	37.23	4,629
35.0	37.97	37.97	4,816	37.97	37.97	4,816	37.97	37.97	4,816	37.97	37.97	4,816	37.97	37.97	4,816
37.0	38.08	38.08	4,844	38.08	38.08	4,844	38.08	38.08	4,844	38.08	38.08	4,844	38.08	38.08	4,844
38.1	38.10	38.10	4,848	38.10	38.10	4,848	38.10	38.10	4,848	38.10	38.10	4,848	38.10	38.10	4,848
40.0	38.10	38.10	4,848	38.10	38.10	4,848	38.10	38.10	4,848	38.10	38.10	4,848	38.10	38.10	4,848
45.0	38.10	38.10	4,848	38.10	38.10	4,848	38.10	38.10	4,848	38.10	38.10	4,848	38.10	38.10	4,848
50.0	38.10	38.10	4,848	38.10	38.10	4,848	38.10	38.10	4,848	38.10	38.10	4,848	38.10	38.10	4,848
55.0	38.10	38.10	4,848	38.10	38.10	4,848	38.10	38.10	4,848	38.10	38.10	4,848	38.10	38.10	4,848
60.0	38.10	38.10	4,848	38.10	38.10	4,848	38.10	38.10	4,848	38.10	38.10	4,848	38.10	38.10	4,848
65.0	38.10	38.10	4,848	38.10	38.10	4,848	38.10	38.10	4,848	38.10	38.10	4,848	38.10	38.10	4,848
70.0	38.10	38.10	4,848	38.10	38.10	4,848	38.10	38.10	4,848	38.10	38.10	4,848	38.10	38.10	4,848
75.0	38.10	38.10	4,848	38.10	38.10	4,848	38.10	38.10	4,848	38.10	38.10	4,848	38.10	38.10	4,848
80.0	38.10	38.10	4,848	38.10	38.10	4,848	38.10	38.10	4,848	38.10	38.10	4,848	38.10	38.10	4,848
85.0	38.10	38.10	4,848	38.10	38.10	4,848	38.10	38.10	4,848	38.10	38.10	4,848	38.10	38.10	4,848
slope angle (radians)			0			0.15			0.06			0.03			0.02
slope angle (degrees)			0			8.47			3.16			2.00			1.00
Time increment for 5mm height			0			248			75			46			23



Table 2

Time (s)	Time (min)	Starting stress (MPa)	Starting ice thickness (mm)	Starting ice thickness (mm)	Cold plate temp (°C)	Growth rate of ice (mm/s)	Internal stress (MPa)	Stress halving time (s)
0	0	0	0	0.500000	-2.1	0.031516	1	129.7
129.7	2	2	0.5	4.586092	-3.2	0.005154	1	148.4
278.1	5	5	0.5	5.351032	-4.2	0.005890	1	170.1
448.1	7	7	0.5	6.352718	-5.3	0.006201	1	195.1
643.2	11	11	0.5	7.562608	-6.3	0.006251	1	224.1
867.3	14	14	0.5	8.963199	-7.4	0.006153	1	257.6
1124.9	19	19	0.5	10.548236	-8.4	0.005976	1	296.5
1421.4	24	24	0.5	12.319851	-9.5	0.005756	1	341.6
1763.0	29	29	0.5	14.286101	-10.5	0.005515	1	394.1
2157.0	36	36	0.5	16.459422	-11.6	0.005266	1	455.1
2612.1	44	44	0.5	18.855779	-12.6	0.005014	1	526.2
3138.3	52	52	0.5	21.494246	-13.7	0.004765	1	609.1
3747.5	62	62	0.5	24.396858	-14.7	0.004521	1	705.9
4453.4	74	74	0.5	27.588640	-15.8	0.004284	1	819.2
5272.5	88	88	0.5	31.097740	-16.8	0.004054	1	951.7
6224.2	104	104	0.5	34.955653	-17.9	0.003832	1	1107.0
7331.2	122	122	0.5	39.197516	-18.9	0.003618	1	1289.3
8620.6	144	144	0.5	43.862469	-20.0	0.003413	1	1503.6
10124.1	169	169	0.5	48.994070	-21.1	0.003216	1	1755.7
11879.8	198	198	0.5	54.640783	-22.1	0.003028	1	2052.7
13932.5	232	232	0.5	60.856530	-23.2	0.002848	1	2403.1
16335.6	272	272	0.5	67.701321	-24.2	0.002677	1	2817.1
19152.7	319	319	0.5	75.241964	-25.3	0.002513	1	3306.9
22459.7	374	374	0.5	83.552871	-26.3	0.002367	1	3887.2
26346.9	439	439	0.5	92.716968	-27.4	0.002209	1	4575.7
30922.6	515	515	0.5	102.826727	-28.4	0.002069	1	5393.6
36316.2	605	605	0.5	113.985322	-29.5	0.001935	1	6366.8
42683.1	711	711	0.5	126.307953	-30.5	0.001809	1	7526.5
50209.6	837	837	0.5	139.923333	-31.6	0.001689	1	8910.3

Table 3

Time (seconds)	Time (minutes)	Starting stress	Starting ice thickness (mm)	Cold plate temp (°C)	Ice-water surface area			log-mean area (mm <sup>2</sup> )	Heat flow, Q (J/s)	Growth rate of ice (mm/s)	Internal stress (MPa)
					Base Wall Length	Side Wall length	Total perimeter				
0	0	0	0.50	-2.1	118	50.8	220.75	403,709	404,263	4,255	0.031559
129.7	2	0.5	4.59	-3.2	105	50.7	215.79	394,644	399,709	687	0.005214
278.1	5	0.5	5.37	-4.2	103	50.6	214.86	392,930	398,844	782	0.005962
448.1	7	0.5	6.38	-5.3	100	50.6	213.83	390,683	397,708	820	0.006286
643.2	11	0.5	7.61	-6.3	96	50.6	212.74	387,966	396,332	823	0.006349
867.3	14	0.5	9.03	-7.4	91	50.5	210.42	384,814	394,731	805	0.006266
1124.9	19	0.5	10.64	-8.4	86	50.5	208.46	381,238	392,910	777	0.006104
1421.4	24	0.5	12.45	-9.5	81	50.4	206.27	377,229	390,861	743	0.005900
1763.0	29	0.5	14.47	-10.5	74	50.3	203.83	372,764	388,670	707	0.005677
2157.0	36	0.5	16.70	-11.6	67	50.2	201.12	367,808	386,017	669	0.005445
2612.1	44	0.5	19.18	-12.6	59	50.2	198.12	362,318	383,175	631	0.005212
3138.3	52	0.5	21.93	-13.7	51	50.1	194.79	356,241	380,012	593	0.004983
3747.5	62	0.5	24.96	-14.7	41	50.0	191.12	349,516	376,490	556	0.004760
4453.4	74	0.5	28.32	-15.8	31	49.8	187.05	342,072	372,564	519	0.004545
5272.5	88	0.5	32.04	-16.8	19	49.7	182.54	333,823	368,180	484	0.004339
6224.2	104	0.5	35.17	-17.9	6	49.6	177.53	324,675	363,274	449	0.004143
7331.2	122	0.5	40.76	-18.9	0	0.0	81.52	149,084	256,006	298	0.005975

## DEVICES FOR PRODUCING CLEAR ICE PRODUCTS AND RELATED METHODS

### CROSS-REFERENCE TO RELATED APPLICATIONS

[0001] This application claims the priority benefit of U.S. Provisional Application No. 63/276,506, filed on Nov. 5, 2021, and the priority benefit of U.S. Provisional Application No. 63/116,453, filed on Nov. 20, 2020, the disclosures of which are herein incorporated by reference in their entirety.

### INCORPORATION BY REFERENCE

[0002] All publications and patent applications mentioned in this specification are herein incorporated by reference in their entirety, as if each individual publication or patent application was specifically and individually indicated to be incorporated by reference in its entirety.

### TECHNICAL FIELD

[0003] This disclosure relates generally to the field of ice manufacturing, and more specifically to the field of clear ice manufacturing. Described herein are devices and methods for producing clear ice.

### BACKGROUND

[0004] From the end of the prohibition era to modern day, craft cocktails are a mainstay in most restaurants and bars. To enhance the overall experience, some restaurants and bars add garnishes and/or specialty ice to the cocktails. Currently, these restaurants and bars buy large blocks of ice that are then cut down in-house to the appropriate size for each drink. Some companies in the space claim to produce clear ice using directional freezing, but the clarity of the ice and scalability of the technology are questionable with many techniques often requiring the use of dangerous saws to cut down larger blocks of ice. Further, issues with standard ice machines include cracking, trapped air bubbles, and water impurities resulting in ice that lacks the desired appeal and appearance.

[0005] Ice can crack under a variety of circumstances experienced during or after a freezing process. Sometimes, during the freezing process, when the exterior of the ice freezes first and then further cools during subsequent freezing, interior tension in the ice is created. This interior tension causes cracking of the ice when it exceeds a certain threshold (e.g., about 1 MPa). Unclear ice may result from super cooling. Water crystallizes around nucleation sites. The ice then grows from this point forming a near perfect lattice structure, given the proper environment. For example, some ice machines slightly super cool the water before freezing. This causes smaller, faster crystallization, which can lead to uneven pressure and greater cloudiness. Lastly, impurities in the water used for freezing can create unclear ice. While impurities play a role in the imperfections in ice, they often aren't the main culprit. Filtered water has on average 30 ppm impurities

[0006] In other cases, some ice machines create cloudy ice because the water contains dissolved air, whereas clear ice contains almost none. During the freezing process, as water turns to ice, and the remaining water reaches saturation level for dissolved gases, the dissolved gas comes out of solution. The gas bubbles stick to the ice-water interface due to

surface adhesion. If these gas bubbles do not get released, they become frozen into the ice, resulting in optical imperfections which affect the straight passage of light (i.e., "cloudiness").

[0007] Furthermore, many extant clear ice machines produce large and unwieldy blocks that are far too large for convenient use in a cocktail as a comestible. In addition to the long freezing times usually required to produce them, often around 24 to 72 hours, these large blocks must be cut down to a size useful as a comestible. Much time and effort then, is expended to produce even a simple and solid shape of clear ice for use in a cocktail.

[0008] Taken together, improper ice freezing techniques and equipment result in less-than-ideal ice for the booming craft cocktail industry. Thus, there is a need for new and useful devices and methods for creating clear ice.

### SUMMARY

[0009] There is a need for new and useful device and method for producing clear ice specifically for use in beverages. In many embodiments, the disclosure herein includes for a device for making clear ice comprising: at least one housing comprising at least one flume surface wall that defines at least one elongate trough; at least one fluid intake disposed to provide a flow of fluid into the at least one elongate trough; at least one drain disposed to drain fluid from at least one elongate trough; wherein the at least a portion of the at least one flume surface wall is in thermal communication with a cooling source; and wherein the at least one fluid intake and the at least one drain are configured to provide a substantially constant flow of fluid to the at least one elongate trough during a freezing operation of the device. In some embodiments, the cooling source is at least one internal cooling cavity defined by the housing, and wherein the device further comprises at least one coolant intake connected to the at least one internal cooling cavity and at least one coolant outtake connected to the at least one internal cooling cavity. In other embodiments, the cooling source is selected from the group consisting of: an evaporator, cold plate, and a condenser.

[0010] In certain embodiments, three flume surface walls of the housing define one elongate trough such that a cross-section of the elongate trough has a U-shape defined by two parallel side flume surface walls and a semicircular base flume surface wall. In other embodiments, three flume surface walls of the housing define one elongate trough such that a cross-section of the elongate trough has a tapered U-shape defined by at least one of the two side flume surface walls having an interior angle greater than about 0 degrees and less than or equal to about 15 degrees from upright and a semicircular base flume surface wall.

[0011] In further embodiments, three flume surface walls of the housing define one elongate trough such that a cross-section of the elongate trough has a U-shape defined by two parallel side flume surface walls and a semi-elliptical base flume surface wall. In other embodiments, three flume surface walls of the housing define one elongate trough such that a cross-section of the elongate trough has a tapered U-shape defined by at least one of the two side flume surface walls having an interior angle greater than about 0 degrees and less than or equal to about 15 degrees from upright and a semi-elliptical base flume surface wall.

[0012] In additional embodiments, three flume surface walls of the housing define one elongate trough such that a

cross-section of the elongate trough has a bracket shape defined by two parallel side flume surface walls orthogonal to a flat base flume surface wall. In other embodiments, three flume surface walls of the housing define one elongate trough such that a cross-section of the elongate trough has a tapered bracket shape defined by at least one of the two side flume surface walls having an interior angle greater than about 0 degrees and less than or equal to about 15 degrees from upright to a flat base flume surface wall.

**[0013]** In some embodiments, the elongate trough has a length of about 45.72 cm to about 3.66 m (about 18 inches to about 12 feet). In other embodiments, the elongate trough has a length of about 2.44 m to about 2.13 m (about 3 feet to about 7 feet). In further embodiments, the elongate trough has a length of about 2.03 m (about 80 inches). In some embodiments, the elongate trough has a depth of about 3.81 cm to about 12.70 cm (about 1.5 to about 5 inches). In other embodiments, the elongate trough has a depth of about 8.89 cm (about 3.5 inches). In some embodiments, the elongate trough has a total depth divided into an ice-forming zone and a fluid overflow zone. In other embodiments, the elongate trough has a total depth of about 12.70 cm (about 5 inches) divided into an ice-forming zone of about 8.89 cm (about 3.5 inches) and a fluid overflow zone of about 3.81 cm (about 1.5 inches.) In further embodiments, a surface area of the flume surface wall at least coextensive with the fluid overflow zone comprises a thermally insulating material. In additional embodiments, the thermally insulating material comprises high density polyethylene. In some embodiments, the elongate trough has a width of about 2.54 cm to about 12.70 cm (about 1 to about 5 inches.) In other embodiments, the elongate trough has a width of about 7.62 cm (about 3 inches.) In some embodiments, the housing defines two or more elongate troughs positioned parallel to one another. In further embodiments, the two or more elongate troughs are positioned anti-parallel to one another.

**[0014]** In some embodiments, the fluid intake comprises a fluid intake manifold that defines a single intake manifold cavity that is fluidly connected to the two or more elongate troughs through a fluid entry portal corresponding to each elongate trough. In further embodiments, the fluid intake manifold further comprises an intake flow divider insert having a porosity of about 10% open area to about 50% open area within the intake manifold cavity. In additional embodiments, the intake manifold cavity is shaped as a rectangular prism and wherein the intake flow divider insert is coupled to opposite corners of the intake manifold cavity, thereby dividing the intake manifold cavity into a first and second triangular prism, wherein at least one fluid inlet pipe is in fluid communication to the first triangular prism, and wherein the corresponding fluid entry portals are in fluid communication to the second triangular prism. In some embodiments, at least one of the fluid entry portals comprises a porous flow straightener insert.

**[0015]** In some embodiments, the drain comprises a drain manifold that defines a single drain manifold cavity that is fluidly connected to the two or more elongate troughs through a fluid exit portal corresponding to each elongate trough. In other embodiments, the drain manifold further comprises a drain flow divider insert having a porosity of about 10% open area to about 50% open area within the drain manifold. In additional embodiments, the drain manifold cavity is shaped as a rectangular prism, and wherein the drain flow divider insert forms an arcuate shape and is

coupled to adjacent corners of the drain manifold cavity, thereby dividing the drain manifold cavity into a first and second portion wherein at least one drainage pipe is in fluid communication to the first portion, and wherein the corresponding fluid exit portals are in fluid communication to the second portion. In some embodiments, at least one of the fluid exit portals comprises a porous flow straightener insert.

**[0016]** In some embodiments, the substantially constant flow of fluid is provided at a velocity of at least about 0.09 m/s (about 0.3 ft/s) through the at least one elongate trough. In other embodiments, the substantially constant flow of fluid is provided at a velocity of at least about 0.21 m/s (about 0.7 ft/s) through the at least one elongate trough.

**[0017]** In some embodiments, the device further comprises at least one lid configured to enclose at least one elongate trough when removably coupled to the housing. In other embodiments, the device further comprises one or more inclusion holders configured to be disposed within a cavity defined by the at least one elongate trough. In some embodiments, the one or more inclusion holders are retractable. In additional embodiments, the one or more inclusion holders are coupled to at least one lid configured to enclose at least one elongate trough when removably coupled to the housing.

**[0018]** In many embodiments, the disclosure herein includes for a method for manufacturing clear ice comprising: providing a device for making clear ice comprising: a housing comprising at least one flume surface wall that defines at least one elongate trough; at least one fluid intake disposed to provide a flow of fluid into the at least one elongate trough; at least one drain disposed to drain fluid from at least one elongate trough; wherein the at least a portion of the at least one flume surface wall is in thermal communication with a cooling source; and wherein the at least one fluid intake and the at least one drain are configured to provide a substantially constant flow of fluid to the at least one elongate trough during a freezing operation of the device; providing a substantially constant flow of fluid down the at least one elongate trough via the fluid intake and the drain; and cooling the at least one flume surface wall to a temperature of less than or equal to about 0 degrees Celsius at the at least one flume surface wall. In some embodiments, the cooling source of the device is at least one internal cooling cavity defined by the housing, and wherein the device further comprises at least one coolant intake valve connected to the at least one internal cooling cavity and at least one coolant outtake valve connected to the at least one internal cooling cavity. In other embodiments, the cooling source is selected from the group consisting of: an evaporator, cold plate, and a condenser.

**[0019]** In some embodiments, the clear ice machine of the method further comprises: at least one or more retractable inclusion holders configured to be disposed within at least one elongate trough; and the method further comprises: securing an item with at least one inclusion holder such that the item is positioned within a cavity defined by the at least one elongate trough. In further embodiments, the method further comprises retracting the one or more retractable inclusion holders after a sufficient accumulation of ice within the elongate trough such that the item remains at least partially embedded in the accumulation of ice upon retraction of the one or more inclusion holders.

**[0020]** In some embodiments of the method, the substantially constant flow of fluid down the at least one elongate

trough has a velocity of at least about 0.09 m/s (about 0.3 ft/s) through the at least one elongate trough. In other embodiments, the substantially constant flow of fluid has a velocity of at least about 0.21 m/s (about 0.7 ft/s) through the at least one elongate trough.

**[0021]** In many embodiments, the disclosure herein includes for a device for introducing inclusions into clear ice comprising: a rigid substrate; at least one inclusion holder connected to the substrate adapted to secure an item in a predetermined position, wherein the inclusions holder comprises retraction mechanism and at least one of a skewer, hook, or clamp; and wherein the retraction mechanism is configured to disengage the item from an inclusion holder and retract the inclusion holder.

**[0022]** In some embodiments, the disclosure herein provides for a device for making clear ice comprising: at least one housing comprising at least two flume surface walls that define at least two elongate troughs arranged parallel to each other; at least one fluid intake disposed to provide a flow of fluid into the at least two elongate troughs; at least one drain disposed to drain fluid from the at least two elongate troughs; wherein the at least a portion of each of the at least two flume surface walls is in thermal communication with a cooling source; wherein the at least one fluid intake and the at least one drain are configured to provide a substantially constant flow of fluid to the at least two elongate troughs during a freezing operation of the device; wherein the fluid intake comprises a fluid intake manifold that defines a single intake manifold cavity that is fluidly connected to the at least two elongate troughs through a fluid entry portal corresponding to each elongate trough; and wherein the drain comprises a drain manifold that defines a single drain manifold cavity that is fluidly connected to the at least two elongate troughs through a fluid exit portal corresponding to each elongate trough. In some embodiments, the cooling source is selected from the group consisting of: an internal cooling cavity defined by the housing, an evaporator, a cold plate, and a condenser.

**[0023]** In some embodiments, the disclosure herein includes for a device for making clear ice comprising: at least one housing comprising at least one flume surface wall that defines at least one elongate trough; at least one fluid intake disposed to provide a flow of fluid into the at least one elongate trough; at least one drain disposed to drain fluid from the at least one elongate trough; wherein the at least a portion of the at least one flume surface wall is in thermal communication with a cooling source; and wherein the at least one fluid intake and the at least one drain are configured to provide a substantially constant flow of fluid to the at least one elongate trough during a freezing operation of the device. In some embodiments, the cooling source is selected from the group consisting of: an internal cooling cavity defined by the housing, an evaporator, a cold plate, and a condenser.

**[0024]** In some embodiments, three flume surface walls of the housing define one elongate trough such that a cross-section of the elongate trough has a tapered U-shape defined by at least one of the two side flume surface walls having an interior angle greater than or equal to about 0 degrees and less than or equal to about 15 degrees from upright and a semicircular base flume surface wall. In other embodiments, three flume surface walls of the housing define one elongate trough such that a cross-section of the elongate trough has a tapered bracket shape defined by at least one of the two side

flume surface walls having an interior angle greater than or equal to about 0 degrees and less than or equal to about 15 degrees from upright to a flat base flume surface wall. In some embodiments, the elongate trough has a total depth divided into an ice-forming zone and a fluid overflow zone, and wherein a surface area of the flume surface wall at least coextensive with the fluid overflow zone comprises a thermally insulating material.

**[0025]** In some embodiments, the housing comprises at least two flume surface walls that define two or more elongate troughs, and wherein the fluid intake comprises a fluid intake manifold that defines a single intake manifold cavity that is fluidly connected to the two or more elongate troughs through a fluid entry portal corresponding to each elongate trough. In further embodiments, the fluid intake manifold further comprises an intake flow divider insert having a porosity of about 10% open area to about 50% open area within the intake manifold cavity, the intake manifold cavity is shaped as a rectangular prism, and the intake flow divider insert is coupled to opposite corners of the intake manifold cavity, thereby dividing the intake manifold cavity into a first and second triangular prism, wherein at least one fluid inlet pipe is in fluid communication to the first triangular prism, and wherein the corresponding fluid entry portals are in fluid communication to the second triangular prism. In additional embodiments, at least one of the fluid entry portals comprises a porous flow straightener insert.

**[0026]** In some embodiments, the housing comprises at least two flume surface walls that define two or more elongate troughs, and wherein the drain comprises a drain manifold that defines a single drain manifold cavity that is fluidly connected to the two or more elongate troughs through a fluid exit portal corresponding to each elongate trough. In further embodiments, the drain manifold further comprises a drain flow divider insert having a porosity of about 10% open area to about 50% open area within the drain manifold cavity, the drain manifold cavity is shaped as a rectangular prism, and the drain flow divider insert forms an arcuate shape and is coupled to adjacent corners of the drain manifold cavity, thereby dividing the drain manifold cavity into a first and second portion wherein at least one drainage pipe is in fluid communication to the first portion, and wherein the corresponding fluid exit portals are in fluid communication to the second portion. In additional embodiments, at least one of the fluid exit portals comprises a porous flow straightener insert.

**[0027]** In some embodiments, the substantially constant flow of fluid is provided at a velocity of at least about 0.09 m/s (about 0.3 ft/s) through the at least one elongate trough. In further embodiments, the device further comprises at least one lid configured to enclose at least one elongate trough when removably coupled to the housing. In additional embodiments, the device further comprises one or more retractable inclusion holders configured to be disposed within a cavity defined by the at least one elongate trough.

**[0028]** In some embodiments, the disclosure herein provides for a method for manufacturing clear ice comprising: providing a device for making clear ice comprising: a housing comprising at least one flume surface wall that defines at least one elongate trough; at least one fluid intake disposed to provide a flow of fluid into the at least one elongate trough; at least one drain disposed to drain fluid from at least one elongate trough; wherein the at least a portion of the at least one flume surface wall is in thermal

communication with a cooling source; and wherein the at least one fluid intake and the at least one drain are configured to provide a substantially constant flow of fluid to the at least one elongate trough during a freezing operation of the device; providing a substantially constant flow of fluid down the at least one elongate trough via the fluid intake and the drain; and cooling the at least one flume surface wall to a temperature of less than or equal to about 0 degrees Celsius at the at least one flume surface wall. In some embodiments of the method, the cooling source is selected from the group consisting of: an internal cooling cavity defined by the housing, an evaporator, a cold plate, and a condenser. In further embodiments, the clear ice machine further comprises: at least one or more retractable inclusion holders configured to be disposed within at least one elongate trough; and the method further comprises: securing an item with at least one inclusion holder such that the item is positioned within a cavity defined by the at least one elongate trough; and retracting the one or more retractable inclusion holders after a sufficient accumulation of ice within the elongate trough such that the item remains at least partially embedded in the accumulation of ice upon retraction of the one or more inclusion holders. In additional embodiments of the method, the substantially constant flow of fluid down the at least one elongate trough has a velocity of at least about 0.09 m/s (about 0.3 ft/s) through the at least one elongate trough

#### BRIEF DESCRIPTION OF THE DRAWINGS

[0029] The foregoing is a summary, and thus, necessarily limited in detail. The above-mentioned aspects, as well as other aspects, features, and advantages of the present technology are described below in connection with various embodiments, with reference made to the accompanying drawings.

[0030] FIG. 1A illustrates an exploded view of one embodiment of a device for making clear ice with a cutout to depict interior features.

[0031] FIG. 1B illustrates the general dimensions of an elongate trough for a device for making clear ice.

[0032] FIG. 2 illustrates a cross-section of one embodiment of a device for making clear ice midway through a freezing operation.

[0033] FIG. 3 illustrates a perspective view of one embodiment of a device for making clear ice

[0034] FIG. 4 illustrates a cross-sectional view of an embodiment of a device for making clear ice.

[0035] FIG. 5 illustrates a cross-sectional view of an embodiment of an elongate trough.

[0036] FIG. 6A illustrates a perspective view of an embodiment of a fluid intake manifold.

[0037] FIG. 6B illustrates a perspective view of an embodiment of a drain manifold.

[0038] FIG. 7 illustrates a perspective view of an embodiment of a flow straightener insert in position within an elongate trough.

[0039] FIG. 8 illustrates a perspective view of another embodiment of a device for making clear ice having one elongate trough shown in cross-section.

[0040] FIG. 9 illustrates a perspective view of another embodiment of a fluid inlet manifold in cross-section.

[0041] FIG. 10 illustrates a perspective view of one embodiment of an ingot removal structure positioned in an elongate trough before the formation of clear ice.

[0042] FIG. 11A illustrates a perspective view of another embodiment of a device for making clear ice having the lid attached.

[0043] FIG. 11B illustrates a profile view of an embodiment for a lid for a clear ice making device.

[0044] FIG. 11C illustrates a cross-sectional view of an embodiment or a device for making clear ice.

[0045] FIGS. 12A-12C illustrate cross-sections of various embodiments of the elongate trough having different cross-sectional shapes.

[0046] FIGS. 13A-13C illustrate cross-sections of various embodiments of the elongate trough having different cross-sectional shapes.

[0047] FIGS. 14A-14C illustrate cross-sections of various embodiments of the elongate trough having different cross-sectional shapes.

[0048] FIGS. 15A-15D illustrate cross-sections of various embodiments of the elongate trough having different cross-sectional shapes.

[0049] FIG. 16 illustrates a method of making clear ice.

[0050] FIGS. 17A-17B illustrate one embodiment for a method of making clear ice.

[0051] FIGS. 18A-18B illustrate one embodiment for a method of making clear ice.

[0052] FIGS. 19A-19B illustrate one embodiment for a method of making clear ice.

[0053] FIGS. 20A-20B illustrate one embodiment for a method of making clear ice.

[0054] FIGS. 21A-21B illustrate one embodiment for a method of making clear ice.

[0055] FIGS. 22A-22B illustrate one embodiment for a method of making clear ice.

[0056] FIGS. 23A-23B illustrate one embodiment for a method of making clear ice.

[0057] FIGS. 24A-24B illustrate one embodiment for a method of making clear ice.

[0058] FIGS. 25A-25B illustrate one embodiment for a method of making clear ice

[0059] The illustrated embodiments are merely examples and are not intended to limit the disclosure. The schematics are drawn to illustrate features and concepts and are not necessarily drawn to scale.

#### DETAILED DESCRIPTION

[0060] The foregoing is a summary, and thus, necessarily limited in detail. The above-mentioned aspects, as well as other aspects, features, and advantages of the present technology will now be described in connection with various embodiments. The inclusion of the following embodiments is not intended to limit the disclosure to these embodiments, but rather to enable any person skilled in the art to make and use the contemplated invention(s). Other embodiments may be utilized, and modifications may be made without departing from the spirit or scope of the subject matter presented herein. Aspects of the disclosure, as described and illustrated herein, can be arranged, combined, modified, and designed in a variety of different formulations, all of which are explicitly contemplated and form part of this disclosure.

[0061] It is an object of the present disclosure to describe devices, systems, and methods for creating clear ice. For example, the devices, systems and methods described herein may be configured to produce clear ice in a variety of shapes that are ready for use in beverages.

**[0062]** Disclosed herein are devices and methods for making clear ice. In particular, the disclosure herein provides for devices and methods allowing for the expedited production of clear ice having an improved quality over preexisting apparatuses and methods. In many embodiments, the devices and methods disclosed herein are adapted for the freezing of water into clear ice; however, one of skill in the art will appreciate how these devices and methods can be adapted to allow for the freezing of other liquids (e.g., ethanol, etc.) in situations where the removal of air bubbles and dissolved impurities is desired. As used herein, the terms “fluid” and “liquid” will be used interchangeably to refer to the material being flowed through the device and being frozen into comestibles. Because water is the chosen fluid to be frozen in many embodiments, the term “water” will be frequently used also; however, this use of the term “water” should not be considered limiting for the reasons stated herein. For similar reasons, the use of the term “ice” to refer to the chosen liquid when frozen should also not be considered limiting either.

**[0063]** In some embodiments, the ice created by the systems and devices described herein may have one or more of the following characteristics: clear, relatively free of impurities, relatively free of gas bubbles, relatively free of dissolved gasses, and/or cracking, may or may not have inclusions (e.g., flowers, liquor, food, etc.), etc. Such characteristics shall not be viewed as limiting in any way.

**[0064]** In some embodiments, water or liquid used to make the clear ice may be deaerated (e.g., gas sweeps, via vacuum, etc.), degassed, purified (e.g., sediment filtered, activated carbon block filtered, granular activated carbon filtered, reverse osmosis filtered, distilled, passed over an ion exchange column, treated with ultraviolet light, ultrafiltered, activated alumina filtered, ionized, etc.), or otherwise treated before being used to make clear ice. The water or liquid may be from a private well, a municipality, ground-water source, reservoir, etc.

#### Systems and Devices

**[0065]** The device functions to produce clear ice. The device is used for the production of clear ice in any situations where transparent ice is desired, such as for consumption in cocktails and other beverages but can additionally or alternatively be used for any suitable applications where a liquid material is frozen. Described broadly for many embodiments, the device generally provides at least one elongate trough or flume in thermal communication with one or more reservoirs or lines of circulating coolant or one or more cooling apparatuses (e.g., cooling plate, element, etc.). A flow of fluid (e.g., water) is provided down at least a portion of the length of the elongate trough during a freezing operation of the device. Clear ice forms on the surface walls of the trough, growing in thickness and filling up to a certain height in the elongate trough, according to various predetermined parameters described herein. In many embodiments, the speed of water (as either laminar or turbulent flow) through the elongate trough can be critical for the formation of clear ice by driving out air bubbles from the ice forming surface. In some embodiments, the device provides a flow of water having a velocity of at least about 0.09 m/s (about 0.3 ft/s) throughout the length of the elongate trough **108**. In other embodiments, the velocity of the water is at least about 0.15 m/s (about 0.5 ft/s). In still other embodiments, the velocity of the water is at least about 0.21 m/s

(about 0.7 ft/s). Once an ingot of ice has been generated within the at least one elongate trough, the freezing operation can be stopped, allowing for the collection of the ice ingot. The generated ice ingot can be subsequently modified to produce a variety of aesthetically pleasing comestibles. As used herein, the terms “elongate trough” and “flume” are considered synonymous and can be used interchangeably throughout.

**[0066]** In many embodiments, the devices and methods presented herein allow for the generation of clear ice at a rate superior to existing techniques. In some embodiments, the devices and methods herein can generate clear ice at a speed of at least about 7 mm/hr measured as linear height of accumulated clear ice on any given point of a surface wall of a trough per unit time. In another embodiment, the devices and methods herein can generate clear ice on a given point at a speed of at least about 24 mm/hr. Furthermore, in the devices and methods described herein, ice grows in multiple directions, thereby effectively halving the thickness of ice through which heat must flow to generate new ice. This provides a dramatic advantage in speed over preexisting technologies that can only grow ice in a single direction. For example, a Clinebell CB3002XD produces ice in one direction at a speed of about 3.0 mm/hr while a CFBI PIM0206 produces ice in one direction at about 6.4 mm/hr. With some embodiments of the devices and methods described herein achieving a total ice formation rate of about 1.27 cm to about 2.54 cm per hour, the disclosure herein can more than double the rate of clear ice formation over these other devices.

**[0067]** As shown in FIG. 1, the device **100** in many embodiments comprises a housing **102** that encloses at least one internal cooling cavity **104**. The housing additionally comprises one or more flume surface walls **106a**, **106b**, and **106c** that define an elongate trough **108** (or in some embodiments, a plurality of elongate troughs **108a**, **108b**, and **108c**), each elongate trough **108** having a first end **110a** and a second end **110b**. During a freezing operation of the device **100**, clear ice is formed within the at least one elongate trough **108**. Across various embodiments, the housing **102** can define any number of elongate troughs **108** greater than or equal to one, and each elongate trough **108** can be shaped by any number of corresponding flume surface walls **106**. In some embodiments, the device **100** comprises six elongate troughs **108**. In certain embodiments, a plurality of elongate troughs **108** and/or internal cooling cavities **104** can be defined by one housing **102**. In other embodiments, each elongate trough **108** and/or internal cooling cavity **104** can be defined by a separate housing **102**. In these embodiments, the plurality of housings **102** (and therefore, plurality of elongate troughs **108** and/or cooling cavities **104**) can be arranged within the device **100** by various structural supports (not shown). In various embodiments, various subsections of the housing can be composed of various materials. For example, some subsections (e.g., flume surface walls **106a**, **106b**, **106c**) can comprise thermally conductive materials, while others (e.g., structural supports and external support walls (not shown)) can comprise thermally insulating materials. In some embodiments featuring a plurality of elongate troughs **108**, the elongate troughs **108** can be arranged parallel to each other. In other embodiments, the elongate troughs **108** can be arranged anti-parallel to each other (e.g., see FIG. 8 below).

[0068] In embodiments wherein each elongate trough 108 has a continuous arcuate shape, the elongate trough can be considered to be defined by a singular flume surface wall 106. However, in many embodiments, an elongate trough 108 can be defined by three flume surface walls 106: two side flume surface walls 106b and 106c and one base flume surface wall 106a. The particular shape and contour of the one or more flume surface walls 106 of each elongate trough 108 define a cross-sectional shape or profile for that elongate trough 108. Various cross-sectional shapes are presented herein. In various embodiments wherein the housing 102 defines more than one elongate trough 108, each elongate trough 108 can have the same cross-sectional profile or a different cross-sectional profile than another elongate trough of the same device 100. In certain embodiments, a single elongate trough 108 can be shaped such that its cross-sectional shape changes over the length of the elongate trough 108. In some of these embodiments, having such a variable shape could assist with the removal of the produced ingot of ice from the device 100. As described herein, the cross-sectional shape of an elongate trough 108 of the device 100 can greatly influence the clarity and therefore the quality of the produced clear ice in many embodiments.

[0069] Furthermore, in some embodiments, the flume surface walls 106 of an elongate trough 108 comprise a single, uniform material. In some embodiments, the flume surface walls 106 comprise aluminum, stainless steel, copper, or another thermally conductive material or thermally conductive metal or alloy. In additional embodiments, the flume surface walls 106 comprise material that is food-safe or otherwise known to be non-toxic when used in the production of comestibles. In other embodiments, various subsections of the flume surface walls 106 can comprise a material different from other subsections of the flume surface walls 106 of the same elongate trough 108. For example, in some embodiments, portions of the flume surface walls 106 outside the intended area of ice formation (i.e., outside the ice-forming zone and within the fluid overflow zone, see FIGS. 2 and 5 below) can comprise a thermally insulating material such as high-density polyethylene (HDPE) while the portions of the flume surface walls 106 comprise a thermally conductive material such as aluminum, stainless steel, or copper.

[0070] FIG. 1B depicts the various dimensions for a generic elongate trough 108. An elongate trough can have a length 120, a depth or height 122, and a width 124. As used herein, the terms “depth” and “height” 122 in reference to an elongate trough 108 will be considered synonymous and will be used interchangeably. In some embodiments, an elongate trough 108 can have a depth 122 measured from its lowest point to the highest point of one of its surface walls 106 ranging from about 2.54 cm to about 25.40 cm (about 1 to about 10 inches). In other embodiments, an elongate trough 108 can have a depth 122 of about 3.81 cm to about 12.70 cm (about 1.5 inches to about 5 inches). In further embodiments, an elongate trough 108 can have a depth 122 of about 5.08 cm to about 12.70 cm (about 2 inches to about 5 inches). In some embodiments, the at least one elongate trough 108 has a depth of about 8.89 cm (about 3.5 inches). In some embodiments, the depth 122 of an elongate trough 108 can be divided by Line A into an ice-forming zone 122b and a fluid overflow zone 122a (also see FIGS. 2 and 5 below). In these embodiments, a total depth 122 of the elongate trough 108 can be subdivided between these zones

in various proportions without deviating from the scope of this disclosure. For example, in some embodiments, an elongate trough 108 can have a total depth 122 of about 12.70 cm (about 5 inches) divided into an ice-forming zone 122b of about 8.89 cm (about 3.5 inches) and a fluid overflow zone 122a of about 3.81 cm (about 1.5 inches).

[0071] In additional embodiments, an elongate trough 108 can have a minimum width 124 measured from between the two closest points of opposite side surface walls 106 of about 2.54 cm to about 30.48 cm (about 1 inch to about 12 inches). In some embodiments, an elongate trough 108 can have a minimum width 124 of about 2.54 cm to about 25.4 cm (1 inch to about 10 inches). In other embodiments, an elongate trough 108 can have a minimum width 124 of about 2.54 cm to about 12.70 cm (about 1 inch to about 5 inches). In certain embodiments, the at least one elongate trough 108 can have a minimum width 124 of about 7.62 cm (about 3 inches).

[0072] In some embodiments, the at least one elongate trough 108 can have a length 120 of at least about 45.72 cm (about 18 inches). In other embodiments, the at least one elongate trough 108 can have a length 120 of at least about 91.44 cm (about 3 feet). In still further embodiments, the at least one elongate trough 108 can have a length 120 of about 1.22 m to about 3.66 m (about 4 to about 12 feet). In other embodiments, the at least one elongate trough 108 can have a length 120 of about 1.22 m to about 2.44 m (about 4 feet to about 8 feet). In other embodiments, the at least one elongate trough 108 can have a length 120 of about 91.44 cm to about 2.13 m (about 3 feet to about 7 feet). In further embodiments, the at least one elongate trough 108 can have a length 120 of about 1.83 m (about 6 feet). In certain embodiments, the at least one elongate trough 108 can have a length 120 of about 2.03 m (about 80 inches). In some embodiments, the at least one elongate trough 108 can have a length 120 of about 45.72 cm to about 3.66 m (about 18 inches to about 12 feet). In various embodiments wherein the housing 102 defines a plurality of elongate troughs 108, each trough can have the same or different length than another elongate trough 108 of the device 100.

[0073] Returning to FIG. 1A, the at least one elongate trough 108 is defined in such a manner by the housing 102 to allow for the flow of water (or another liquid, in various embodiments) down at least a portion of the length of an elongate trough 108 from at least one fluid intake 112 to at least one drain 114. In some embodiments, a first end 110a of an elongate trough 108 can be understood to mean an end nearest a fluid intake 112, and a second end 110b of an elongate trough 108 can be understood to mean an end nearest a drain 114. In these embodiments, it can be understood that fluid (e.g., water) flows down an elongate trough 108 from the fluid intake 112 to the drain 114, i.e., from the first end 110a to the second end 110b. As illustrated in the embodiment of FIG. 1, each elongate trough 108 can be fed by a single fluid intake 112 and drained by a single drain 114; however, different numbers, arrangements and placements of these valves are possible without deviating from the scope of this disclosure (e.g., FIGS. 11A-11C). Because ice forms and grows upon at least a portion of the flume surface walls 106 during a freezing operation of the device 100, the one or more fluid intake 112 and drain 114 can be positioned to allow for the free passage of water over the growing ice ingot (i.e., in the fluid overflow zone 122a) regardless of the



ingot's height or at least up to a predetermined height of ice (i.e., in the ice-forming zone **122b**).

**[0074]** In some embodiments, the at least one fluid intake **112** and at least one drain **114** are configured to provide a flow of water such that the entire volume defined within the elongate trough **108** is filled with moving water except for the portion occupied by the growing mass of clear ice during a freezing operation of the device **100**. In some embodiments, the at least one fluid intake **112** and drain **114** provide fluid (e.g., water) having a velocity of at least about 0.09 m/s (about 0.3 ft/s) throughout the length of the elongate trough **108**. In other embodiments, the velocity of the water is at least about 0.15 m/s (about 0.5 ft/s). In still other embodiments, the velocity of the water is at least about 0.21 m/s (about 0.7 ft/s). In other embodiments, the at least one fluid intake **112** and at least one drain **114** are adapted to provide a flow of water such that the entire volume defined within the ice-forming zone **112b** and a portion of the fluid overflow zone **112a** is filled with moving water except for the portion occupied by the growing mass of clear ice during a freezing operation of the device **100**.

**[0075]** The at least one fluid intake **112** and/or drain **114** are fluidly connected to a fluid supply such as a water supply (not shown) and any other additional equipment appreciated by those of skill in the art to allow for a substantially continuous flow of fluid to the at least one elongate trough **108** during a freezing operation of the device **100**. In some embodiments, the fluid supply provides a substantially continuous stream of new fluid to the device throughout the entire freezing operation; in other embodiments, the fluid supply can recirculate at least a portion of a starting volume of fluid throughout the freezing operation. In certain embodiments, de-aerated water can be supplied or recirculated to the device **100** from the fluid supply.

**[0076]** In many embodiments, an appropriate velocity of fluid into the at least one elongate trough **108** can be critical for the formation of clear ice as opposed to cloudy or opaque ice. In various circumstances, quickly freezing a volume of still or slow-moving water can trap air bubbles and impurities within the ice, resulting in a hazy appearance. However, in addition to other advantages of the device **100** described herein, the device's **100** flow of water can mitigate the trapping of air bubbles within the ice during the freezing process, even at high rates of freezing. In some embodiments, the flow of water can also be turbulent flow. Therefore, the device **100** as disclosed herein is capable of producing a solid ingot of clear ice of sufficient quality faster than other known methods.

**[0077]** In some embodiments, the flow rate of fluid remains constant over the whole duration of a freezing operation of the device **100**. In other embodiments, the flow rate of the fluid varies over a freezing operation of the device **100**. In some embodiments, periods of flow reversal may occur in which the fluid intake **112** becomes the fluid drain **114**, and the fluid drain **114** becomes the fluid intake **112**.

**[0078]** At least one internal cooling cavity **104**, defined by housing **102**, is in thermal communication with the flume surface walls **106** across many embodiments, thereby establishing the heat transfer necessary for the formation of clear ice in the at least one elongate trough **108**. In some embodiments, the at least one internal cooling cavity **104** is a singular internal cooling cavity **104**. In other embodiments, the at least one internal cooling cavity **104** is a plurality of cooling cavities that are in thermal communication with

various subsets of flume surface walls **106** and/or portions of flume surface walls **106**. In some embodiments for an elongate trough **108** having a base flume surface wall **106a** and two side flume surface walls **106b** and **106c**, each flume surface wall **106a**, **106b**, and **106c** are each in thermal communication with a unique internal cooling cavity **104** defined by the housing **102**. Across various embodiments, the at least one internal cooling cavity **104** can include various structures and architectural features within in order to facilitate an even flow and distribution of coolant within it. In some embodiments, these structures can include but are not limited to mesh grates.

**[0079]** During a freezing operation of the device **100**, the at least one internal cooling cavity **104** can be at least partially filled by a circulating coolant sufficient to lower the temperature of at least a portion of one or more flume surface walls **106** to about 0° C. or colder. In another embodiment, the at least one internal cooling cavity **104** can be at least partially filled by a circulating coolant sufficient to lower the temperature of at least a portion of one or more flume surface walls **106** to about -45° C. In still other embodiments, the at least one internal cooling cavity **104** can be at least partially filled by a circulating coolant sufficient to lower the temperature of at least a portion of one or more flume surface walls **106** to about 0° C. to about -20° C. In further embodiments, the at least one internal cooling cavity **104** can be at least partially filled by a circulating coolant sufficient to lower the temperature of at least a portion of one or more flume surface walls **106** to about -2° C. to about -20° C. In still further embodiments, the at least one internal cooling cavity **104** can be at least partially filled by a circulating coolant sufficient to lower the temperature of at least a portion of one or more flume surface walls **106** to about -2° C. to about -35° C. In some embodiments, the internal cooling cavity **106** and its contained circulating coolant are adapted to hold at least a portion of one or more flume surface walls **106** to a constant temperature during a freezing operation of the device **100**. In other embodiments, the internal cooling cavity **106** and its contained circulating coolant are adapted to provide a variable temperature to at least a portion of one or more flume surface walls **106** during a freezing operation of the device **100** that changes according to a predetermined temperature schedule.

**[0080]** In many embodiments, the volume of the at least one internal cooling cavity **104** can be minimized and/or insulated from portions of the housing **102** that are not flume surface walls **106** in order to minimize the amount of coolant needed to sufficiently cool the flume surface walls **106** for the generation of ice. As one of skill in the art will appreciate, the one or more cooling cavities may be replaced with other cooling apparatuses (e.g., cooling plate, cooling elements, etc.), without departing from the scope of the present disclosure.

**[0081]** One of skill in the art will appreciate that a variety of coolants can be used including, but not limited to, propylene glycol, ethylene glycol, and brine. For the circulation of coolant, the at least one internal coolant cavity **104** is fluidly connected to a coolant circulation system (not shown) via at least one coolant intake **116** and at least one coolant outtake **118**. As illustrated in the embodiment of FIG. 1, the singular internal cooling cavity **104** is fed by a singular coolant intake **116** and drained by a singular coolant outtake **118**; however, different numbers, arrangements and placements of these features are possible without deviating

from the scope of this disclosure. In particular, embodiments wherein the housing encloses a plurality of internal cooling cavities **104** can comprise various numbers, arrangements, placements, and fluid connectivities of internal cooling cavities **104**, coolant intakes **116**, and coolant outtakes valves **118**, without deviating from the scope of this disclosure. One of skill in the art will appreciate that the coolant circulation system can comprise any number of pumps, compressors, evaporators, etc. that are needed to provide a sufficient circulation of coolant for the features of the disclosure as described herein.

[0082] The embodiment of the device **100** of FIG. 1A has at least one internal cooling cavity **104**; however, the at least one internal cooling cavity **104** can be replaced by other cooling sources, such as cold plates, condensers, evaporators, etc. in alternative embodiments. For example, evaporator pipes (not shown) could be efficiently snaked in contact with and directly behind the flume surface walls **106** to allow heat transfer between the flume surface walls **106** and the evaporator pipes. In this manner, it can be considered that device **100** is arranged such that at least a portion of the at least one flume surface wall **106** is in thermal communication with a cooling source, and wherein the at least one cooling cavity **104** of FIG. 1A is one embodiment of such a cooling source. In alternate embodiments, the evaporator pipes of the above example can be considered cooling cavities defined by the housing.

[0083] In various embodiments, the device **100**, optionally, further comprises a lid **120** that comprises a substrate that removably couples or attaches to the housing **102** to enclose and thermally insulate the at least one elongate trough **108**. As illustrated in the embodiment of FIG. 1, a singular lid **120** can be adapted to enclose all of the elongate troughs **108a**, **108b**, and **108c**. In alternative embodiments, a plurality of lids **120** can be adapted to cover each elongate trough individually or in distinct subsets. In further embodiments, the lid **120** can comprise one or more inclusion holders **122**, such as small skewers, clips, or clamps, positioned on the substrate of the lid such that the holders can secure an item (e.g., a piece of fruit or other edible good, a flower, etc.) within an elongate trough **108** when the lid **120** is fitted to the housing **102** of the device **100**. In some embodiments, the inclusion holders **122** are retractable such that they can disengage the item and be retracted when sufficient ice has formed within the elongate trough to secure the item within the growing ice ingot in a predetermined position as arranged for by the positioning of the inclusion holder **122**. In various embodiments, the inclusion holders can be retracted by mechanical means (e.g., automatically or manually actuated) or manually (e.g., by hand). In some embodiments, the inclusion holders can be retracted by mechanical means when a predetermined duration of time has expired during a freezing operation of the device. Alternatively, or additionally, one or more side surface walls **106**, inclusion holders **122**, or other components of device **100** may be sensorized such that a progress of ice formation may be monitored for removal of the inclusion holders. Further, in some embodiments, the inclusion holders can be retracted by mechanical means when the ice formed in the trough **106** reaches a predetermined volume during a freezing operation of the device.

[0084] In other embodiments, the lid **120** as described above can be adapted to fit onto other clear ice makers including but not limited to a Clinebell Equipment

CB300X2D or a Clinebell Equipment CI-4. Such an adapted lid **120** in these embodiments would provide similar ease of introduction of inclusions to clear ice generated by these alternate devices.

[0085] In still further embodiments, the inclusion holders **122** can be adapted to position an item within an elongate trough **108** without the use of a lid **120**. In these embodiments, the inclusion holders **122** can be suspended over uncovered elongate troughs **108** by a scaffold or frame, or they can be integrated in a position on a top edge of the housing **102** itself.

[0086] FIG. 2 depicts a cross-section of an exemplary device **200** for making clear ice midway during a freezing operation. In this embodiment, the housing **202** of the device **200** defines a single elongate trough **204** with a semicircular base flume surface wall **206** and a first and second side flume surface wall **208** and **210**. These surface flume walls **206**, **208**, **210** are in thermal communication with an internal cooling cavity **212** or other cooling apparatus enclosed by the housing **202**. During a freezing operation of the device **200**, sufficient coolant is circulated through the internal cooling cavity **212** such that water **214** flowing down the length of the elongate trough **204** in its ice-forming zone **205b** as divided by Line A can freeze on the surface flume walls **206**, **208**, **210** to form an ingot of clear ice. FIG. 2 depicts a midway point during a freezing operation in which clear ice **216** (shaded area) has begun to form on the flume surface walls **206**, **208**, **210** but has not yet frozen sufficient water to form a solid ingot of clear ice. Arrows **218** illustrate the general direction of ice formation during this process. When a solid ingot of clear ice has formed, any remaining flowing water can traverse the elongate trough **204** in the fluid overflow zone **205a**.

[0087] FIG. 3 depicts a perspective view of one embodiment of a device **300** for making clear ice. The device **300** comprises a housing **302** enclosing six elongate troughs **304** each in thermal communication with an individual internal cooling cavity (not shown, see FIGS. 4-5). A fluid intake **314** directs a fluid (not shown) to be frozen in the device **300** (e.g., water) into a fluid intake manifold **315** which then distributes the fluid into each of the elongate troughs **304** via a fluid entry portal (not shown) positioned at the first end **310a** of each elongate trough **304**. After flowing through the length of an elongate trough **304**, fluid can exit via a fluid exit portal **319** into a singular fluid drain manifold **317** that collects the fluid from all elongate troughs **304**. The fluid drain manifold **317** can then direct the fluid out of the device **300** via a fluid outlet **316**. A fluid supply (not shown) can be connected to the fluid intake **314** and optionally the fluid outlet **316** as well in order to provide a continuous flow of fluid through the elongate troughs **304** during a freezing operation of the device. In some embodiments, the fluid supply and/or mechanical components of the fluid intake **314** and/or fluid outlet **316** can regulate at least one of the quantity, flow rate, and temperature of the fluid entering the elongate troughs **304**.

[0088] Coolant outlet and inlet lines **308** connect the internal cooling cavities (not shown) to a coolant supply (not shown) that chills and circulates coolant through the device **300** during a freezing operation. As discussed herein, various coolants can be employed, including, but not limited to, propylene glycol, ethylene glycol, and brine. In some embodiments, the coolant supply and/or mechanical components of the coolant outlet and inlet lines **308** can regulate

at least one of coolant temperature and flow rate into the plurality of internal cooling cavities either individually or collectively. In alternative embodiments, the internal cooling cavities can be replaced by other cooling sources, such as cold plates, condensers, evaporators, etc.

[0089] The device 300 can also comprise a lid 320, in some embodiments. A lid, when constructed of thermally insulating materials, can assist in maintaining a uniform and adequately cool temperature within the device 300 that can contribute to the generation of clear ice along all the flume surface walls of all elongate troughs 304. In the embodiment shown in FIG. 3, the lid 320, shown in an open configuration, comprises two halves separately hinged at either the first end 310a or the second end 310b and of sufficient dimensions as to fully enclose the elongate troughs 304 when both halves of the lid 320 are rotated down to a closed configuration (not shown). One of skill in the art will appreciate that a variety of lid constructions and attachments can be employed without deviating from the scope of this disclosure. In some embodiments, no lid 320 is present on the device 300. In further embodiments, the exterior walls 303 of the housing 302 can comprise thermally insulating materials including, but not limited to, polyoxymethylene (POM), polyurethane, polystyrene, fiberglass, and mineral wool, etc. to further assist in the maintenance of a satisfactorily and uniformly chilled environment within the device 300 to contribute towards efficient generation of clear ice in each of the elongate troughs 304. In additional embodiments, the device 300 can rest upon adjustable legs 321 or leveled rails (not shown) that can automatically or manually level the device 300 so that an equal fluid level or a level fluid surface can be more readily attained through the elongate troughs 304 during a freezing operation of the device 300.

[0090] FIG. 4 depicts a cross-section of an embodiment of a device 400 for making clear ice. The device 400 comprises housing 402 defining a plurality of elongate troughs 404 enclosed on five sides (one side not shown) by a plurality of exterior walls 403. In many embodiments, the exterior walls 403 can comprise thermally insulating material as described elsewhere herein. In this embodiment, the elongate troughs 404 are each in thermal communication with a separate internal cooling cavity 408. During a freezing operation of the device 400, coolant is circulated by a coolant supply through each of the internal cooling cavities 408 while a fluid (e.g., water) is circulated through each of the elongate troughs 404. In some embodiments, such as the embodiment of FIG. 4, the elongate troughs have a greater height than the intended height of the ingot of clear ice to be formed. Having such a fluid overflow space (see FIG. 5 below) above an ice-forming zone can allow for the passage of fluid through an elongate trough 404 even after a substantial height of clear ice has developed, and in some embodiments, maintaining this constant flow of fluid can be important for producing aesthetically pleasing clear ice. To impede the formation of clear ice above the intended height, the elongate troughs 404 can comprise a thermally insulating strip 422 along each side flume wall of the elongate trough 404 starting at a height substantially matching that of the intended ingot height and continuing to the top of the trough 404 (i.e., coextensive with the fluid overflow zone). In this manner, the elongate troughs 404, in certain embodiments, can comprise multiple materials as described herein. For example, the portions of an elongate trough 404 on which

ice formation is desired can be composed of or include aluminum, stainless steel, or another material that easily conducts heat while the insulating strips 422 can comprise high density polyethylene (HDPE), polyoxymethylene (POM) (a.k.a. Delrin <sup>®</sup>), or another thermally insulating material or polymer.

[0091] FIG. 4 also depicts one embodiment of an internal architecture of a fluid intake 414 and fluid outlet 416 although other arrangements of plumbing can be employed in alternative embodiments. In the embodiment depicted in FIG. 4, the fluid outlet 416 is attached to a fluid drain manifold 417 positioned at a second end 410b (the first end not depicted) of the device 400.

[0092] FIG. 5 shows a cross-sectional profile of the embodiment of an elongate trough of FIG. 4 above. The profile 500 of the elongate trough, which in some embodiments can be considered as part of housing of the device as described herein, defines an ice-forming zone 504b and a fluid overflow zone 504a (divided by Line A for illustrative purposes) with a semi-circular base surface flume wall 502a and two side surface flume walls 502b and 502c. In the embodiment of FIG. 5, at least a portion of the flume surface walls 502a-c of the ice-forming zone 504b are in contact with an internal coolant cavity 506 defined by a coolant cavity wall 507. In other embodiments, all portions of the surface flume walls 502a-c of the ice-forming zone 504b are in contact with the internal coolant cavity 506. In order to impede the formation of ice within the fluid overflow zone 504a, insulating strips 505a and 505b comprising a thermally insulating material line the side surface flume walls 502b and 502c for their portions that are coextensive with the fluid overflow zone 504a in the embodiment of FIG. 5. In alternative embodiments, insulating strips 505a and 505b can extend into the ice-forming zone 504b to slow down the rate of ice formation as it approaches the border of the fluid overflow zone 504a. In this manner, it can be said that a surface area of one or more surface flume walls 502b and 502c at least coextensive with the fluid overflow zone 504a can comprise a thermally insulating material. In certain embodiments, the insulating strips 505a and 505b comprise HDPE. In some embodiments, side surface flume walls 502b and 502c both form a right angle compared to Line B which is tangent to the lowest point of semicircular base surface flume wall 502a. In other embodiments, one or both of side surface flume walls 502b and 502c lean outward from the center of the ice-forming zone 504b, forming a non-right angle with Line B. See the analogous discussion of  $\theta$ ,  $\theta^1$ , and  $\theta^2$  below in FIGS. 12A-12C, 13A-13C, and 14A-14C.

[0093] In the embodiment of FIG. 5, the flume surface walls 502a-c and the coolant cavity wall 507 are monolithic and can be produced by extruding a singular material (e.g., aluminum, etc.) through a mold (not shown) or by roll forming or die stamping (e.g., stainless steel, etc.). In this embodiment, the insulating strips 505a and 505b are subsequently attached in notches 508a and 508b that are configured to receive them so that the insulating strips 505a and 505b sit substantially flush with the side surface flume walls 502b and 502c as depicted. A variety of coupling means can be employed to attach the insulating strips 505a and 505b to the profile 500, including, but not limited to, adhesives, mechanical fasteners, etc. In other embodiments, the profile 500 can be produced in various subassemblies that are subsequently attached to form the complete elongate trough. In these embodiments, various coupling means can be

employed to secure the subassemblies to each other, including, but not limited to, welds, adhesives, and mechanical fasteners.

**[0094]** FIG. 6A depicts a perspective view down the width of an embodiment of fluid intake manifold **600a**. Fluid (e.g., water) enters the intake manifold cavity **601a** of the fluid inlet manifold **600a** through at least one fluid intake pipe **602a**. In some embodiments, the at least one fluid intake pipe **602a** is coupled to the fluid intake **414** of FIG. 4. In other embodiments, the fluid intake manifold **600a** can be considered part of the fluid intake **112** of FIG. 1 or the fluid intake **414** of FIG. 4. In the embodiment of FIG. 6A, there are four fluid inlet pipes **602a**, but any number greater than or equal to one can be employed in alternative embodiments. Fluid leaves the manifold cavity **601a** through fluid entry portals **604a** that direct the flow of fluid into one or more elongate troughs (not shown). In many embodiments, there is only one fluid entry portal **604a** for each elongate trough, although any number of elongate troughs (and therefore corresponding fluid entry portals **604a**) can connect to a fluid intake manifold **600a**. In some embodiments, the dimensions of a fluid entry portal **604a** match that of the profile of the corresponding elongate trough (its ice-forming and fluid overflow zones combined, e.g., see FIG. 5). In other embodiments, the dimensions of a fluid entry portal **604a** differ from that of the profile of the corresponding elongate trough. In certain embodiments, the dimensions of a fluid entry portal **604a** match the width and profile of the corresponding elongate trough but is shorter than the full height of the elongate trough. In many embodiments, however, each fluid entry portal **604a** is fitted with a flow straightener insert (not shown, see FIG. 7) that organizes the turbulence of the flow of fluid into the elongate trough.

**[0095]** In many embodiments, a fluid intake manifold **600a** further comprises a cavity divider **606a**. The cavity divider **606a** is a rigid or semi-rigid but porous insert that mitigates the formation of a circular current of fluid within the manifold cavity **601a** as fluid makes its way from the fluid inlet pipes **602a** to the fluid entry portals **604a**. In many embodiments, the cavity divider **606a** has a porosity of 5% to 75% open area. In other embodiments, the cavity divider **606a** has a porosity of 10% to 50% open area. In further embodiments, the cavity divider **606a** has a porosity of 15% to 30% open area. In the embodiment of FIG. 6A, the cavity divider **606a** reaches across opposite corners, dividing the rectangular prism of the manifold cavity **601a** into two triangular prisms **603a** and **603b**, respectively, such that the fluid inlet pipes **602a** are in fluid communication to a first triangular prism **603a** and the fluid entry portals **604a** are in fluid communication to a second triangular prism **603b**. The term “fluid communication” is hereby intended to mean that elements “in fluid communication” can pass fluid (e.g., water) between each other. In alternative embodiments, the manifold cavity **601a** and cavity divider **606a** can take other geometries. For example, the manifold cavity **601a** may take the shape of a cylinder, triangular prism, or the like. In other embodiments, the cavity divider **606a** is absent. In many embodiments, the flow of fluid into and out of the manifold cavity **601a** is sufficient to completely fill or substantially fill (approximately 95% filled or more) the manifold cavity **601a**.

**[0096]** FIG. 6B depicts a perspective view down the length of a drain manifold **600b**. Fluid (e.g., water) enters the drain manifold cavity **601b** of the drain manifold **600b**

through at least one fluid exit portal **604b**. In many embodiments, there is one fluid exit portal **604b** for each connected elongate trough (not shown), although any number of elongate troughs (and therefore fluid exit portals **604b**) can connect to a drain manifold **600b**. In some embodiments, the dimensions of a fluid exit portal **604b** match that of the profile of the corresponding elongate trough (its ice-forming and fluid overflow zones combined, e.g., see FIG. 5). In other embodiments, the dimensions of a fluid exit portal **604b** differ from that of the profile of the corresponding elongate trough. In certain embodiments, the dimensions of a fluid exit portal **604b** match the width and profile of the corresponding elongate trough but is shorter than the full height of the elongate trough. In many embodiments, however, each fluid exit portal **604b** is fitted with a flow straightener insert (not shown, see FIG. 7) that organizes the turbulence of the flow of fluid out of the elongate trough. Fluid leaves the drain manifold cavity **601b** through at least one drainage pipe **602b**. In some embodiments, the at least one drainage pipe **602b** is coupled to the fluid outlet **416** of FIG. 4. In the embodiment of FIG. 6B, there are four drainage pipes **602b**, but any number greater than or equal to one can be employed in alternative embodiments.

**[0097]** In many embodiments, a drain manifold **600b** further comprises a cavity divider **606b**. The cavity divider **606b** is a rigid or semi-rigid but porous insert that mitigates the formation of a circular current of fluid within the drain manifold cavity **601b** as fluid makes its way from the fluid exit portals **604b** to the drainage pipes **602b**. In many embodiments, the cavity divider **606a** has a porosity of 5% to 75% open area. In other embodiments, the cavity divider **606a** has a porosity of 10% to 50% open area. In further embodiments, the cavity divider **606a** has a porosity of 15% to 30% open area. In the embodiment of FIG. 6B, the cavity divider **606a** forms an arcuate shape between adjacent corners of the same side of the rectangular prism of the drain manifold cavity **601b** thereby dividing the drain manifold cavity **601b** into a first **603a** and second portion **603b** wherein at least one drainage pipe **602b** is in fluid communication to the first portion **603a** and wherein the corresponding fluid exit portals **604b** are in fluid communication to the second portion **603b**. In alternative embodiments, the drain manifold cavity **601b** and cavity divider **606b** can take other geometries. For example, the drain manifold cavity **601b** may take the shape of a cylinder, triangular prism, or the like. In other embodiments, the cavity divider **606b** is absent. In many embodiments, the flow of fluid into and out of the manifold cavity **601b** is sufficient to completely fill or substantially fill (approximately 95% filled or more) the manifold cavity **601b**.

**[0098]** FIG. 7 depicts a perspective view of a flow straightener insert **700** positioned within an elongate trough **750** attached to either a fluid entry portal or fluid exit portal of the elongate trough **750**. In many embodiments, a flow straightener insert **700** comprises a rigid or semi-rigid material defining one or more apertures or openings **702**. These openings **702** can have a variety of shapes, number, and arrangement in the flow straightener insert **700** across multiple embodiments, but in many embodiments, the openings are all circular (except for those abutting against the edge of the insert **700**), have the same diameter, and spaced in series of packed columns as shown in FIG. 7. In some embodiments, the highest one or more openings **702a** of the flow straightener insert **700** is no taller than the maximum height

of the corresponding fluid inlet portal or fluid exit portal. In some embodiments, the highest one or more openings **702a** are no taller than Line C, a predetermined height that is within the fluid overflow zone of the elongate trough **750** but less than the maximum height of the elongate trough **750**. In some embodiments, each elongate trough **750** has a flow straightener insert **700** positioned at both its corresponding fluid entry portal and fluid exit portal. In other embodiments, each elongate trough **750** has a flow straightener insert **700** positioned at only one of its fluid entry portal or fluid exit portal. In still other embodiments, an elongate trough **750** can lack a flow straightener insert **700** at both its fluid entry portal and fluid exit portal. Across various embodiments, the flow straightener insert **700** can be coupled to the flow entry portal or fluid exit portal by a variety of coupling means, including, but not limited to adhesives, mechanical fasteners, etc.

**[0099]** In many embodiments, the flow straightener insert **700** serves to organize the flow of fluid into or out of an elongate trough **750**. As a particular range of velocities can be critical for the development of clear ice at speeds superior to existing technologies in some embodiments, the flow straightener insert **700** can prevent or mitigate the formation of swirling vortexes of fluid within the elongate trough **750**. Such vortexes can generate areas within the elongate trough **750** where fluid is moving too slowly, thus leading to cloudy sections within the generated ingot of clear ice.

**[0100]** FIG. 8 depicts a perspective view and partial cross-section of an alternate embodiment of a device **800** for making clear ice. The device **800** comprises a housing **802** that defines eight elongate troughs **804** showing one elongate trough **804a** in cross-section. In other embodiments, any number of elongate troughs can be employed. Fluid (e.g., water) enters each elongate trough **804** through a corresponding individual inlet manifold **806** and exits via a corresponding individual drain manifold **808** (only drain manifold **808a** of elongate trough **804a** is visible in FIG. 8). Adjacent elongate troughs **804** are arranged anti-parallel to each other such that the inlet manifold **806** of one elongate trough is adjacent to one or more drain manifolds **808** on a given terminal end **801a** and **801b** of the device **800** and vice versa. In some embodiments, such an arrangement allows for a more compact arrangement of elongate troughs **804**. Each elongate trough **804** is in thermal communication with an internal coolant cavity **805** (only the internal cooling cavity **805a** of elongate trough **804a** is visible) through which coolant (supplied by a coolant supply, coolant inlet and outlet lines, all not shown) flows during a freezing operation of the device **800**. Fluid (e.g., water) enters the inlet manifolds **806** and exits from the drain manifolds **808** via a fluid supply, and fluid inlet and outlet lines (all not shown).

**[0101]** FIG. 9 shows a perspective cross-sectional view of an embodiment of an inlet manifold **906** of a device **900** for forming clear ice. In some embodiments, the inlet manifold **906** of FIG. 9 can be the same embodiment of those depicted in FIG. 8. The inlet manifold **906** in this embodiment features an inlet pipe **908** that connects to an internal cavity **910** defined by an outer casing **907** of the inlet manifold **906**. A flow guide **912** within the internal cavity **910** redirects incoming fluid around its perimeter through an edge gap **916** to enter a guide cavity **917**. From the guide cavity **917**, fluid can then pass through the one or more channels **920** of a flow straightener plug **918** to enter an elongate trough **904**. The

flow straightener plug **918** can have any number of channels **920** in various embodiments, and in some embodiments, such as the embodiment of FIG. 9, some channels **920** can have longer lengths than others and can extend farther into the guide cavity **917** than other channels **920**. This arrangement of the flow guide **912** and flow straightener plug **918** organizes the general flow of fluid into the inlet manifold **906** in a manner that avoids inefficient whirlpooling of fluid while maintaining sufficient velocity into the elongate trough **904** for the generation of clear ice. In many embodiments, fluid exits an elongate trough **804** through a flow straightener plug **918** and into the drain manifold **808**.

**[0102]** FIG. 10 depicts a detailed perspective view of one embodiment of a device **1000** for producing clear ice with an embodiment of an ingot removal structure **1030** in position over an elongate trough **1004**. In many embodiments, an ingot removal structure **1030** comprises a support beam **1032** through which an ingot implant **1034** is secured extending down into the ice-forming zone of the elongate trough **1004**. An ingot removal structure **1030** can be positioned at one or both terminal ends of an elongate trough (i.e., near a fluid entry or exit portal **1019** of a fluid inlet or drain manifold **1017**) in various embodiments. In other embodiments, one or more ingot removal structures **1030** can be positioned at other locations along the length of the elongate trough **1004**. During a freezing operation of the device **1000**, clear ice accumulates in the elongate trough **1004**. Because the ingot implant **1034** extends into the ice-forming zone, the ingot implant **1034** becomes embedded in the ingot of ice. Once the freezing operation of the device **1000** has been completed and the ingot of ice is to be removed from the elongate trough **1004**, the ingot can be lifted out of the trough by gripping the support beam **1032** of at least one ingot removal structure **1030**. An ingot removal structure **1030** can be removed from an ingot of ice by mechanically cutting off a length of the ingot that contains the ingot implant **1034**. By positioning an ingot removal structure **1030** very near the terminal ends of an elongate trough, very little ice must be cut to remove the ingot removal structure **1030**. Because the ingot implant **1034** is in contact with the fluid that forms a comestible, it can be valuable that the ingot implant **1034** comprises food-safe material. In some embodiments, the ingot implant **1034** is a food-safe zip tie that passes through a hole in the support beam **1032**, although one will appreciate that many alternative shapes, materials, and arrangements can be employed to form an ingot removal structure **1030** without deviating from the scope of this disclosure.

**[0103]** FIG. 11A depicts a perspective view of an alternate embodiment of a device **1100** for making clear ice. The device **1100** comprises a housing **1102** defining a single elongate trough **1104** as well as at least one internal cooling cavity (not shown). A coolant manifold **1106** can control the flow of coolant in and out of the at least one internal cooling cavities via a plurality of coolant inlets and outlets **1108** when connected by various plumbing elements (not shown). In embodiments wherein the device **1100** comprises a plurality of internal cooling cavities the coolant manifold **1106** can control the flow of coolant through each internal cooling cavity individually. In some embodiments, the coolant manifold **1106** can further comprise coolant inlets and outlets **1108** of its own.

**[0104]** The device **1100** comprises a removable lid **1110** depicted in FIG. 11A in an attached position with its rigid

substrate **1112** secured to the housing **1102**. The lid **1110** features a plurality of fluid inlets **1114** and outlets **1116** (analogous to the fluid intake **112** and drain **114** of FIG. 1A, respectively) along its length in this embodiment. In many embodiments, this arrangement of fluid inlets **1114** and outlets **1116** can allow for a turbulent flow of water through the whole length of the elongate trough **1104** that is fully filled with water during a freezing operation of the device **1100**. In additional embodiments, positioning the fluid inlets **1114** and outlets **1116** in the lid can keep them above the freezing level, thereby leaving them operation for the full duration of a freezing operation. Although this embodiment of the lid **1110** is used with an embodiment of the device **1100** that comprise at least one internal cooling cavity in FIG. 11A, the embodiment of the lid **1110** of FIG. 11A can be used on a device using an alternate cooling source for the flume surface walls, such as a cold plate, evaporator, or condenser.

**[0105]** In further embodiments, the lid **1110** can further comprise one or more inclusion holders **1118** that extend through the lid **1110** into the ice-making volume defined by the elongate trough **1104**. In the embodiment of FIG. 11A, a plurality of inclusion holders **1118** are all attached to a gantry **1120** that allows for a synchronized motion (e.g., a retraction motion) of the inclusion holders **1118**. FIG. 11B illustrates a profile view of a lid **1110** unattached to the housing **1102** of the device **1100**. The inclusion holders **1118** indeed traverse the substrate **1112** of the lid **1110**, and each inclusion holder **1118** can be fitted to secure an inclusion **1122** (e.g., a piece of fruit or other edible good, a flower, etc.) such that the inclusion **1122** can be held in position within an elongate trough **1104** during a freezing operation of the device **1100**.

**[0106]** FIG. 11C depicts a cross-sectional view of an embodiment of the device **1100** of FIG. 11A. In this embodiment, the elongate trough **1104** is defined by three flume surface walls **1124a**, **1124b**, and **1124c** that are each in thermal communication with a unique corresponding internal cooling cavity **1126a**, **1126b**, and **1126c**. Each internal cooling cavity **1126a**, **1126b**, and **1126c** can be supplied by unique a coolant inlets and outlets **1128a**, **1128b**, and **1128c**. The compartmentalized arrangement of the cooling cavities **1126a**, **1126b**, and **1126c** in this embodiment allow for a more specific control of the temperatures experienced at each flume surface wall **1124a**, **1124b**, and **1124c** during a freezing operation of the device **1100**.

**[0107]** FIGS. 12A-12C, 13A-13C, and 14A-14C depict various embodiments of possible cross-sectional shapes for an elongate trough. In FIGS. 12A-12C, the elongate trough is defined by a semicircular base surface wall **1202a**, **1202b**, **1202c**, and a first and second side surface walls **1204a**, **1204b**, **1204c** and **1206a**, **1206b**, **1206c**, respectively. In FIG. 12A, the side surface walls **1204a** and **1206a** are vertical in comparison to a plane tangent to the lowest point of the base surface wall **1202a**. In FIG. 12B, the first side surface wall **1204b** has an internal angle  $\theta$  away from a vertical position as defined in FIG. 12A. Across many embodiments, the angle  $\theta$  can be any value greater than about  $0^\circ$  but less than or equal to about  $15^\circ$ . In other embodiments, the angle  $\theta$  can be about  $0.25^\circ$  to about  $10^\circ$ . In still other embodiments, the angle  $\theta$  can be about  $0.25^\circ$  to about  $8^\circ$ . In further embodiments, the angle  $\theta$  can be about  $0.25^\circ$  to about  $5^\circ$ . In still further embodiments, the angle  $\theta$  can be about  $1^\circ$  to about  $10^\circ$ . In FIG. 12B, despite the first

side surface wall's **1204b** deviation from upright, the second side surface wall **1206b** stands upright, creating an asymmetric cross-sectional shape for the elongate trough. In FIG. 12C, the first side surface wall **1204c** has an internal angle  $\theta^1$  away from vertical and the second side surface wall **1206c** has an internal angle  $\theta^2$  away from vertical. In many embodiments, both  $\theta^1$  and  $\theta^2$  can each be any value greater than about  $0^\circ$  but less than or equal to about  $15^\circ$ . In other embodiments, the angles  $\theta^1$  and  $\theta^2$  can each be about  $0.25^\circ$  to about  $10^\circ$ . In still other embodiments, the angles  $\theta^1$  and  $\theta^2$  can each be about  $0.25^\circ$  to about  $8^\circ$ . In further embodiments, the angles  $\theta^1$  and  $\theta^2$  can each be about  $0.25^\circ$  to about  $5^\circ$ . In still further embodiments, the angles  $\theta^1$  and  $\theta^2$  can each be about  $1^\circ$  to about  $10^\circ$ . In some embodiments,  $\theta^1$  and  $\theta^2$  have the same value, creating a symmetric cross-sectional shape for the elongate trough. In alternate embodiments,  $\theta^1$  and  $\theta^2$  have the different values, creating an asymmetric cross-sectional shape for the elongate trough. Therefore, across many embodiments, at least one of the two side flume surface walls **1204a**, **1204b**, **1204c** and **1206a**, **1206b**, **1206c** can have an interior angle greater than or equal to about  $0$  degrees and less than or equal to about  $15$  degrees from upright.

**[0108]** FIGS. 13A-13C depict analogous cross-sectional shapes for an elongate trough wherein the base surface wall **1302a**, **1302b**, **1302c** is semi-elliptical, and FIGS. 14A-14C further depict analogous cross-sectional shapes for an elongate trough wherein the base surface wall **1402a**, **1402b**, **1402c** is flat, creating a square base when both the first and second side surface walls **1404a** and **1406a** are vertical or perpendicular to base surface wall **1402a** (shown in FIG. 14A).

**[0109]** In many embodiments of FIGS. 13A-13C, the angles  $\theta$ ,  $\theta^1$ , and  $\theta^2$  can each be any value greater than about  $0^\circ$  but less than or equal to about  $15^\circ$ . In other embodiments, the angles  $\theta$ ,  $\theta^1$ , and  $\theta^2$  can each be about  $0.25^\circ$  to about  $10^\circ$ . In still other embodiments, the angles  $\theta$ ,  $\theta^1$ , and  $\theta^2$  can each be about  $0.25^\circ$  to about  $8^\circ$ . In further embodiments, the angles  $\theta$ ,  $\theta^1$ , and  $\theta^2$  can each be about  $0.25^\circ$  to about  $5^\circ$ . In still further embodiments, the angles  $\theta$ ,  $\theta^1$ , and  $\theta^2$  can each be about  $1^\circ$  to about  $10^\circ$ . In some embodiments,  $\theta^1$  and  $\theta^2$  have the same value, creating a symmetric cross-sectional shape for the elongate trough. In alternate embodiments,  $\theta^1$  and  $\theta^2$  have the different values, creating an asymmetric cross-sectional shape for the elongate trough. Therefore, across many embodiments, at least one of the two side flume surface walls **1304a**, **1304b**, **1304c** and **1306a**, **1306b**, **1306c** can have an interior angle greater than or equal to about  $0$  degrees and less than or equal to about  $15$  degrees from upright.

**[0110]** In many embodiments of FIGS. 14A-14C, the angles  $\theta$ ,  $\theta^1$ , and  $\theta^2$  can each be any value greater than about  $0^\circ$  but less than or equal to about  $15^\circ$ . In other embodiments, the angles  $\theta$ ,  $\theta^1$ , and  $\theta^2$  can each be about  $0.25^\circ$  to about  $10^\circ$ . In still other embodiments, the angles  $\theta$ ,  $\theta^1$ , and  $\theta^2$  can each be about  $0.25^\circ$  to about  $8^\circ$ . In further embodiments, the angles  $\theta$ ,  $\theta^1$ , and  $\theta^2$  can each be about  $0.25^\circ$  to about  $5^\circ$ . In still further embodiments, the angles  $\theta$ ,  $\theta^1$ , and  $\theta^2$  can each be about  $1^\circ$  to about  $10^\circ$ . In some embodiments,  $\theta^1$  and  $\theta^2$  have the same value, creating a symmetric cross-sectional shape for the elongate trough. In alternate embodiments,  $\theta^1$  and  $\theta^2$  have the different values, creating an asymmetric cross-sectional shape for the elongate trough. Therefore, across many embodiments, at least one of the two side flume

surface walls **1404a**, **1404b**, **1404c** and **1406a**, **1406b**, **1406c** can have an interior angle greater than or equal to about 0 degrees and less than or equal to about 15 degrees from upright. In some embodiments, the joints connecting side surface walls **1404a**, **1404b**, **1404c**, **1406a**, **1406b**, **1406c** to the base surface wall **1402a**, **1402b**, **1402c**, are sharp angles (i.e., as depicted in FIGS. **14A-14C**). In some embodiments, the joints connecting side surface walls **1404a**, **1404b**, **1404c**, **1406a**, **1406b**, **1406c** to the base surface wall **1402a**, **1402b**, **1402c** are bent angles having some form of arcuate geometry to smooth the transition between the flat base surface wall **1402a**, **1402b**, **1402c** and the side surface walls **1404a**, **1404b**, **1404c**, **1406a**, **1406b**, **1406c**. In some embodiments, the arcuate joint transition accounts for about 30% or less of the total length of width the base surface wall **1402a**, **1402b**, **1402c**. In some embodiments, the arcuate joint transition accounts for about 20% or less of the total length of width the base surface wall **1402a**, **1402b**, **1402c**.

[0111] The embodiments of possible cross-sectional shapes for an elongate flume depicted in FIGS. **12A-12C**, **13A-13C**, and **14A-14C** are intended to be illustrative and not limiting of the total possible cross-sectional shapes available. FIGS. **15A-15D** depict further illustrative examples of cross-sectional shapes including various irregular shapes. As shown in FIG. **15A**, an elongate trough can have a base surface wall **1502a** having an arcuate but lopsided shape. As shown in FIG. **15B**, an elongate trough can have a base surface wall **1502b** having a waveform pattern. As shown in FIG. **15C**, an elongate trough can have two base surface walls **1502c1** and **1502c2** to define a V-shape for a base. In other embodiments, an elongate trough can comprise any number of flume surface walls. FIG. **15D**, for example, shows an embodiment having three base surface walls **1502d1**, **1502d2**, and **1502d3** forming a V-shape that forms a shoulder with the side surface wall **1506d**. Although FIGS. **15A-15D** are depicted as having vertical sidewalls and sharp joint transitions, one of skill in the art will appreciate that other embodiments can have sloping sidewalls and smoother, bent arcuate joint transitions as described above for FIGS. **12A-12C**, **13A-13C**, and **14A-14C**.

[0112] For some embodiments, having a  $\theta$ ,  $\theta^1$ , and  $\theta^2$  greater than about  $0^\circ$  can be valuable to the production of clear ice during a freezing operation of the device. In certain embodiments of the device, clear ice forms on at least a portion of the base flume wall and the two side surface walls (as shown in FIG. **2**). As discussed above, this arrangement can be considered “multi-directional freezing” in certain embodiments. Multi-directional freezing can greatly expedite clear ice production since ice can accumulate on multiple surfaces simultaneously to form a single piece of clear ice. However, when the portions of clear ice that are forming on opposite side surface walls begin to approach each other, at least two situations can occur that can damage the clarity of the ice. First, the space between the ice of the two side walls can fill in too quickly with new ice, therefore trapping air and other impurities inside a narrow portion of the ingot of ice. This creates a plane of cloudy ice that can run through a portion of the volume of the ingot, thus ruining the desired clear ice properties. Second, ice bridges can develop between the two opposing ice sheets accumulating on the side surface walls. These ice bridges disrupt the desired simple crystal lattice for the clear ice and can yield internal cracks, visible to an observer, in the final product once the

spaces around the bridges are similarly frozen. This, too, ruins the desired clarity of the final product.

[0113] In some embodiments with certain flow rates, angling one or more side surface walls of an elongate trough can avoid or mitigate the above concerns. By sloping their planes of ice formation slightly away from each other, the device can, in certain embodiments, instead direct a more gradual filling in of ice from the bottom of a “v-shaped” or “u-shaped” valley rather than suddenly abutting two vertical planes of clear ice into each other. In many embodiments, sloping the side surface walls does slightly lengthen the required time to produce an ingot of clear ice compared to an analogous elongate trough having vertical walls (see Example 1, below). In other embodiments, the device can generate an ingot of clear ice using elongate troughs having vertical side surface walls by intentional control of flow rate and temperature of the three side walls.

[0114] Once an ingot of ice has been produced, such as by an embodiment of the device of the above figures, it can be further processed to efficiently generate a plurality of comestibles with aesthetically pleasing shapes and/or additional properties as described herein.

#### Methods

[0115] As shown in FIG. **16**, a method **1600** for producing clear ice of one embodiment includes providing a device for making clear ice in block **S1602**, optionally positioning an item with at least one inclusion holder in block **S1604**, providing a flow of water down at least one elongate trough in block **S1606**, circulating coolant through the at least one internal cooling cavity in block **S1608**, and optionally retracting the one or more inclusion holders in block **S1610**. The method functions to produce clear ice, particularly ingots of clear ice. The method is used for the production of clear ice for consumption in beverages but can additionally, or alternatively, be used for any suitable applications. The method can be configured and/or adapted to function for any suitable rapid freezing of liquids to produce frozen substances.

[0116] The method **1600** includes for providing a device for making clear ice according to block **S1602**. The device for making clear ice can be any of the embodiments of devices described elsewhere herein and depicted in the various figures above.

[0117] Next, at step **S1604**, the method **1600** optionally includes for positioning at least one item in at least one inclusion holder. As described above, the inclusion holders can secure an item within the space defined by an elongate trough during a freezing operation of the device such that the one or more items will be inside the ingot of clear ice upon completion of the freezing cycle. These inclusion holders, such as skewers, clips, or clamps, can be affixed to a lid of the device or elsewhere as described above.

[0118] At Step **S1606**, the method **1600** then includes providing a flow of water down at least one elongate trough. In many embodiments, the flow of water is provided to the elongate trough by at least one fluid intake valve positioned in the housing of the device or in the lid of the device and drained by at least one drain valve as described above. In other embodiments, the flow of water can be provided by other means appreciated by those of skill in the art. A sufficient flow rate of water is required in order to exclude air bubbles and impurities from the growing layer of clear

ice on at least one flume surface wall during a freezing operation of the device in many embodiments.

**[0119]** At Step S1608, the method next includes cooling at least a portion of at least one flume surface wall of the at least one elongate trough to produce a growing layer of clear ice on the at least a portion of at least one flume surface wall. In many embodiments, this cooling can be performed by the circulation of coolant through at least one internal coolant cavity as described above. Also as discussed above, coolant is provided to the device by a coolant supply system via at least one coolant intake valve and is cycled out by at least one coolant outtake valve in many embodiments. In alternate embodiments, Step S1608 includes for providing and utilizing an alternative cooling apparatus including but not limited to cold plates, compressors, etc. for the generation of the temperatures needed to produce clear ice on the one or more flume surface walls.

**[0120]** In some embodiments, the at least a portion of at least one flume surface wall is cooled to a temperature of about 0° C. or less. In another embodiment, the at least a portion of at least one flume surface wall is cooled to about -45° C. In still other embodiments, the at least a portion of at least one flume surface wall is cooled to about 0° C. to about -20° C. In further embodiments, the at least a portion of at least one flume surface wall is cooled to about -2° C. to about -20° C. In further embodiments, the at least a portion of at least one flume surface wall is cooled to about -2° C. to about -35° C. In some embodiments, the at least a portion of at least one flume surface wall is adapted to hold a constant temperature during a freezing operation of the device. In other embodiments, the at least a portion of at least one flume surface wall is adapted to provide a variable temperature during a freezing operation of the device that changes according to a predetermined temperature schedule.

**[0121]** In many embodiments, the cooling of step S1608 involves gradually decreasing the temperature of the flume surface walls over time. In many embodiments, a gradual decrease in temperature allows the device to overcome the inherent insulating properties of the ice as it forms. Because ice freezes directionally outwards from the flume surface walls that relay the chilled temperatures to the flow of water as shown in FIG. 2, the insulating properties of ice proportionally impede the heat transfer between the flume surface walls and flow of water as the layer of ice grows. In some embodiments, the temperature of the flume surface walls decreases from about 0° C. to about -30° C. over the duration of a freezing operation of the device. In other embodiments, the temperature of the flume surface walls decreases from about -2° C. to about -20° C. over the duration of a freezing operation of the device. In some embodiments, a freezing operation of the device lasts about 12 hours or less. In other embodiments, a freezing operation of the device lasts about 30 minutes to about 10 hours. In still further embodiments, a freezing operation of the device lasts about 30 minutes to about 4 hours. In additional embodiments, a freezing operation of the device lasts about 2 hours.

**[0122]** At optional Step S1610, the method 1600 provides for retracting the at least one inclusion holder. In many embodiments, the at least one inclusion holder should be retracted before the growing layer of clear ice comes into contact with the inclusion holder. In many embodiments, the at least one inclusion holder is retracted after a sufficient accumulation of ice has formed within the elongate trough

such that the item remains at least partially embedded in the accumulation of ice upon retraction of the at least one inclusion holder. In some embodiments, the at least one inclusion holder is retracted by mechanical means. In some of these embodiments, the at least one inclusion holder is retracted mechanically after a certain duration of time of a freezing operation has passed or after a predetermined volume of ice has formed. In other embodiments, the at least one inclusion holder is retracted manually. In various embodiments wherein there are a plurality of inclusion holders, each or a subset can be collectively retracted simultaneously or individually at different times and/or at different volumes of formed ice.

**[0123]** Regardless of the presence or operation of any inclusion holders, the method 1600 allows for the flow of water and the circulation of coolant until a desired quantity of clear has formed within the at least one elongate trough. The resulting ingot of clear ice will have a length and cross-sectional shape determined by or related to those of the corresponding elongate trough in which it formed. Once the ingot of ice has formed to a predetermined or desired height or volume, the flow of water and circulation of coolant can be ceased, and the ingot of ice can be removed by a variety of means appreciated by those of skill in the art, including but not limited to letting the ingot slightly melt and removing it by mechanical means. In some embodiment, the slight melting can be provided by a circulation of warmer coolant in the at least one internal cooling cavities. In other embodiments, one or more side surface walls may further include one or more heating elements or heating means, such that an external surface of the ice ingot may be melted to facilitate ice removal from the device. In some embodiments, the ingot of ice can be removed vertically by lifting it out of an elongate trough, but in other embodiments, the ingot of ice can be removed horizontally by sliding it out of the elongate trough through an openable or removable end wall. In some embodiments, the device is adapted such that the ingot of ice adheres to a surface of the lid such that removing the lid additionally removes the ingot of ice with it.

**[0124]** FIGS. 17A-25B show various exemplary, non-limiting methods for forming clear ice using any ice device described herein or known in the art. As used herein, the terms “flow inlet” and “flow inlet valve” can be considered synonymous with “fluid intake valve” and will be used interchangeably. Similarly, as used herein, the term “outlet” and “outlet valve” can be considered synonymous with “drain valve.” As one of skill in the art will appreciate, any of the parameters, temperature ranges, stages, rates, time periods, circulation, agitation, etc. of any of FIGS. 17A-25B may be exchanged with each other. Various parameters were adjusted in each of the figures. For example, temperature of ice forming surface (e.g., flume surface walls), temperature of water, time, end plateau (i.e., flow or temperature stays constant for a time period at the end of the method, mid-cycle plateau (i.e., flow or temperature stays constant for a time period during the recipe), flow paths (i.e., flow inlets that are located towards the outside of the elongate trough are being controlled separately from flow inlets towards a center of the elongate trough), flow direction (i.e., flow reversal; pump direction is switched such that the inlets become the outlets and the outlets become the inlets), circulation (e.g., maintain some degree of water flow at the ice formation boundary to prevent dissolved gasses from



freezing in the water), initial cool down (i.e., an initial aggressive ramp down in temperature to bring the water in the molds close to freezing more quickly, for example an initial temperature drop to about 0° C. to about -15° C.), annealing (i.e., period at the end of the method after the ice has been formed that allows for the temperature gradient in the ice to lessen or reduce internal stresses that can lead to cracking), and flow rate of the coolant. For example, one or more temperature plateaus may be from about 3 minutes to about 100 minutes. Further for example, an annealing period may be characterized by a coolant source temperature between about -2° C. and about 15° C. and the percentage max flow of about 0% to about 5%. As shown below, each step in each method may include or comprise about 1 to about 20 minutes; about 2 minutes to about 15 minutes; about 5 minutes to about 10 minutes; substantially 5 minutes; substantially 6 minutes; substantially 8 minutes; about less than 10 minutes; etc. As shown in the following figures, the initial steps may vary in time from about 5 minutes to about 10 minutes and then the subsequent steps may vary in time from about 2.5 minutes to about 7.5 minutes. Although, as one of skill in the art will appreciate decreasing or increasing a step by about 1 minute to about 10 minutes will not depart substantially from the scope of this disclosure.

**[0125]** In some embodiments, a method for forming clear ice includes: providing a device, for example, any of the above embodiments; optionally inserting a skewer or clip through the lid, the skewer or clip being coupled to an item or configured to release a fluid into a cavity in the ice (e.g., skewer defines one or more apertures); circulating, using the fluid inlet and outlet valves, a fluid in the elongate trough; optionally varying overtime one or both of: a temperature of the cooling apparatus or source or a fluid flow, through the fluid inlet valve, as a percentage of max flow; and optionally retracting the skewer or clip when the ice formation encases at least a portion of the item.

**[0126]** As shown above, in some embodiments, temperature of the flume surface walls (hereinafter, "surface temperature") is varied (e.g., 0° C. and about -25° C. or any of the ice making methods described elsewhere herein); in other embodiments, the flow rate of water (hereinafter, "water flow rate") is varied (e.g., percentage of max water flow between about 5% and about 100% or any of the ice making methods described elsewhere herein). In some embodiments, both surface temperature and water flow rate are varied. In some embodiments, neither temperature nor flow rate are varied. In various other embodiments, the temperature of the water flowing through the elongate troughs (hereinafter "water temperature") can be varied solely or in addition to the other parameters named above.

**[0127]** In some embodiments, the device is configured to receive an inclusion holder (e.g., a skewer or clip), such that the method includes inserting the skewer or clip and optionally retracting the skewer or clip at a predetermined time. The predetermined time is dependent on a type of item coupled to the skewer, dependent on a volume of the elongate trough, a random predetermined time, or combination thereof. In some embodiments, ice formation is monitored via a sensorized mold and/or skewer/clip such that the skewer or clip is removed or retracted based on a progress of ice formation. The method may optionally include releasing the ice from the elongate trough with the item encased therein, for example via gravity, manual removal, automatic removal (e.g., ejector pin, air, hydraulics, etc.).

In some embodiments, the method optionally includes sealing a lid to the device, for example via a gasket, pressure seal, screw type seal, etc.

**[0128]** FIGS. 17A-17B show varied surface temperature over time at a constant flow. As shown in FIG. 17A, surface temperature is decreased incrementally over time. The size of the increments may vary over time; alternatively, the increments may not vary over time (i.e., are fixed), such that increment remains the same over time. In one exemplary embodiment, the increment is 0.1° C., such that the surface temperature decreases by an increment of about 0.1° C. over time. In other embodiments, the increment may be less than about 0.1° C. or more than about 0.1° C. In some embodiments, the increment may be from about 0.25° C. to about 5° C.; 0.5° C. to about 5° C.; about 1° C. to about 5° C.; about 0.5° C. to about 3° C.; about 0.5° C. to about 2.5° C.; etc.

**[0129]** Further, as shown in FIGS. 17A-17B, a surface temperature variation may be from about 0° C. to about -10° C.; about 0° C. to about -25° C.; about 0° C. to about -10° C.; about -2° C. to about -7° C.; about -1° C. to about -10° C.; etc. For example, the surface temperature may decrease gradually over time. In the example shown in FIGS. 17A-17B, the percent max water flow remains at 100% through the duration of the ice making method. Alternatively, as one of skill in the art will appreciate, and as shown elsewhere herein, the percent max water flow may vary over time.

**[0130]** Further, as shown in FIGS. 17A-17B, a skewer or clip may be retracted at one or more of: a predetermined time, based on a degree of ice formation, based on a volume of ice formation, based on a type of inclusion or item coupled to the skewer or clip, based on a sensor reading (e.g., temperature, clarity of ice, volume of ice, etc.) or a combination thereof. As shown in FIGS. 17A-17B and for any of the embodiments described herein, a skewer or clip may be retracted after about 30 minutes to about 180 minutes; about 45 minutes to about 165 minutes; about 30 minutes to about 140 minutes; about 45 minutes to about 125 minutes; about 60 minutes to about 110 minutes; about 75 minutes to about 90 minutes; at about 90 minutes; at about 120 minutes; etc. from or after the start time (time=0) of the method. Alternatively, or additionally, in any of the embodiments described herein, a skewer or clip, may include a heating means (e.g., heating element, heating coils, etc.) such that the skewer or clip may be heated and retracted at any time during or after the ice making process.

**[0131]** FIGS. 18A-18B show varied flow water rate over time at a constant surface temperature. As shown in FIG. 18A, water flow rate, as a percentage of max water flow, is decreased incrementally over time. The size of the increments may vary over time; alternatively, the increments may not vary over time, such that increment remains the same over time. In one exemplary embodiment, the increment is about 2%, such that the water flow rate decreases by an increment of about 2% over time. In other embodiments, the increment may be less than about 2% or more than about 2%. In some embodiments, the increment may be from about 0.5% to about 95%; about 1% to about 95%; about 2% to about 10%; about 1% to about 5%; about 5% to about 10%; about 5% to about 95%; about 10% to about 90%; about 15% to about 85%; about 20% to about 80%; about 25% to about 75%; about 30% to about 70%; about 35% to about 65%; about 40% to about 60%; about 45% to about 55%; about 45% to about 50%; etc. For example, the percent

max water flow may decrease gradually over time. In the example shown in FIGS. 18A-18B, the surface temperature remains constant or fixed during the method. For example, the surface temperature may remain close to or at about  $-5^{\circ}\text{C}$ . to about  $-10^{\circ}\text{C}$ . For example, the surface temperature may remain at about or substantially  $-7^{\circ}\text{C}$ . Alternatively, as one of skill in the art will appreciate, and as shown elsewhere herein, the surface temperature may vary over time. In this embodiment, the skewer or clip is retracted after about or substantially 120 minutes from the start (time=0) of the method.

**[0132]** FIGS. 19A-19B show varied water flow rate and surface temperature over time. As one can appreciate, FIGS. 19A-19B show a combination of the methods of FIGS. 17A-17B and FIGS. 18A-18B. In this embodiment, both the surface temperature and the water flow rate are varied over time. The variation may be incremental, at a fixed interval, or variable, in a defined pattern or stochastic within a defined range.

**[0133]** FIGS. 20A-20B show a method of making clear ice. The method includes an initial cool down cycle where the surface temperature remains fixed for a period of time. For example, the surface temperature may be set at or below about  $0^{\circ}\text{C}$ .; at or below about  $-2^{\circ}\text{C}$ .; at or below about  $-4^{\circ}\text{C}$ .; at or below about  $-6^{\circ}\text{C}$ .; at or below about  $-8^{\circ}\text{C}$ .; at or below about  $-10^{\circ}\text{C}$ .; at or below about  $-12^{\circ}\text{C}$ .; at or below about  $-14^{\circ}\text{C}$ .; at or below about  $-16^{\circ}\text{C}$ .; at or below about  $-18^{\circ}\text{C}$ .; at or below about  $-20^{\circ}\text{C}$ . The surface temperature may be set between about  $0^{\circ}\text{C}$ . and about  $-25^{\circ}\text{C}$ .; about  $-5^{\circ}\text{C}$ . and about  $-20^{\circ}\text{C}$ .; about  $-10^{\circ}\text{C}$ . and about  $-15^{\circ}\text{C}$ .; or about or substantially  $-10^{\circ}\text{C}$ . The period of time may range from about 1 minute to about 20 minutes about 1 minute to about 15 minutes; about 5 minutes to about 15 minutes; about 5 minutes to about 10 minutes; about 6 minutes to about 8 minutes; etc. This initial cool down cycle may also be referred to herein as a start plateau or beginning plateau. Further, as shown in FIGS. 20A-20B, the method may include an end plateau, such that the surface temperature is kept substantially constant for a period of time. For example, the surface temperature may be maintained between about  $0^{\circ}\text{C}$ . and about  $-15^{\circ}\text{C}$ .; about  $-5^{\circ}\text{C}$ . and about  $-15^{\circ}\text{C}$ .; about  $-5^{\circ}\text{C}$ . and about  $-10^{\circ}\text{C}$ .; about  $-6^{\circ}\text{C}$ . and about  $-8^{\circ}\text{C}$ .; etc. for about 5 to about 150 minutes; about 10 minutes to about 145 minutes; about 20 minutes to about 140 minutes; about 75 minutes to about 115 minutes; about 90 minutes to about 110 minutes; about 100 minutes to about 110 minutes; etc. In between the initial plateau and the end plateau, the surface temperature may be incrementally decreased from about  $-2^{\circ}\text{C}$ . to about  $-7^{\circ}\text{C}$ . For example, the surface temperature may incrementally decrease by  $0.2^{\circ}\text{C}$ . between the beginning and end plateaus. Alternatively, the increment may be between about  $0.1^{\circ}\text{C}$ . and about  $0.5^{\circ}\text{C}$ .; about  $0.1^{\circ}\text{C}$ . and  $1^{\circ}\text{C}$ .; about  $0.1^{\circ}\text{C}$ . and about  $0.3^{\circ}\text{C}$ .; about  $0.1^{\circ}\text{C}$ . and about  $0.4^{\circ}\text{C}$ .; etc. For the embodiment shown in FIGS. 20A-20B, the water flow rate may vary over time as shown and described for FIGS. 19A-19B. Further, in the embodiment of FIGS. 20A-20B, the skewer or clip is retracted at about or substantially 120 minutes from a start of the method, as described elsewhere herein.

**[0134]** FIGS. 21A-21B show a method of making clear ice that is similar to that of FIGS. 20A-20B, except that the method of FIGS. 21A-21B further includes an annealing phase at or near the end of the method. For example, an

annealing phase may comprise a period of warmer surface temperatures to lessen or reduce internal stress that may lead to cracking. In some embodiments, an annealing phase may be characterized by one or more surface temperature periods that range in temperature from about  $-5^{\circ}\text{C}$ . to about  $20^{\circ}\text{C}$ .; about  $-2^{\circ}\text{C}$ . to about  $15^{\circ}\text{C}$ .; about  $0^{\circ}\text{C}$ . to about  $10^{\circ}\text{C}$ ., or any range or subrange therebetween. For example, an annealing phase may include a first period at a surface temperature between about  $-5^{\circ}\text{C}$ . and about  $5^{\circ}\text{C}$ . and a second period at a surface temperature between about  $5^{\circ}\text{C}$ . and about  $15^{\circ}\text{C}$ . Alternatively, an annealing phase may be characterized by one period at a fixed surface temperature or a plurality of periods, each at a different temperature from a previous temperature and a future temperature. Each period of time may range from about 2 minutes to about 60 minutes; about 5 minutes to about 30 minutes; about 5 minutes to about 25 minutes; about 5 minutes to about 20 minutes; about 5 minutes to about 15 minutes; about 10 minutes to about 15 minutes; or any range or subrange therebetween. Further, in the embodiment of FIGS. 21A-21B, the skewer or clip is retracted at about or substantially 120 minutes from a start of the method, as described elsewhere herein.

**[0135]** FIGS. 22-22B show a method of making clear ice that is similar to that of FIGS. 21A-21B, except that the method of FIGS. 22A-22B further includes a mid-method plateau, such that the surface temperature is kept substantially constant for a period of time. For example, the surface temperature may be maintained between about  $-10^{\circ}\text{C}$ . and about  $0^{\circ}\text{C}$ .; about  $-8^{\circ}\text{C}$ . and about  $0^{\circ}\text{C}$ .; about  $-6^{\circ}\text{C}$ . and about  $0^{\circ}\text{C}$ .; about  $-6^{\circ}\text{C}$ . and about  $-2^{\circ}\text{C}$ .; about  $-5^{\circ}\text{C}$ . and about  $-2^{\circ}\text{C}$ .; about  $-5^{\circ}\text{C}$ . and about  $-3^{\circ}\text{C}$ .; or any range or subrange therebetween for about 5 to about 100 minutes; about 10 minutes to about 95 minutes; about 20 minutes to about 90 minutes; about 30 minutes to about 75 minutes; about 30 minutes to about 60 minutes; about 30 minutes to about 50 minutes; etc. In one example, a mid-cycle plateau may include a surface temperature of about  $-4^{\circ}\text{C}$ . for about 45 minutes. In between the initial plateau and the end plateau, the surface temperature may be incrementally decreased from about  $-2^{\circ}\text{C}$ . to about  $-7^{\circ}\text{C}$ . For example, the surface temperature may incrementally decrease by  $0.2^{\circ}\text{C}$ . between the beginning and end plateaus. Alternatively, the increment may be between about  $0.1^{\circ}\text{C}$ . and about  $0.5^{\circ}\text{C}$ .; about  $0.1^{\circ}\text{C}$ . and  $1^{\circ}\text{C}$ .; about  $0.1^{\circ}\text{C}$ . and about  $0.3^{\circ}\text{C}$ .; about  $0.1^{\circ}\text{C}$ . and about  $0.4^{\circ}\text{C}$ .; etc. For the embodiment shown in FIGS. 20A-20B, the water flow rate may vary over time as shown and described for FIGS. 19A-19B. Further, in the embodiment of FIGS. 20A-20B, the skewer or clip is retracted at about or substantially 120 minutes from a start of the method, as described elsewhere herein.

**[0136]** FIGS. 23A-23B show another method of making clear ice. The method is similar to that shown in FIGS. 22A-22B, except the method of FIGS. 23A-23B includes shifting or adjusting between fluid inlet valves positioned in an inner region and fluid inlet valves positioned in an outer region. In one exemplary embodiment, the inner and outer inlet valves are arranged similar to the embodiment shown in FIG. 11A, with the term “inner” meaning towards the middle of the length of the elongate trough. As shown in FIGS. 23A-23B, the overall water flow rate, as a percentage of max water flow, decreases incrementally over time. The size of the increments may vary over time; alternatively, the increments may not vary over time, such that increment

remains the same over time or is fixed. In one exemplary embodiment, the increment is about 2%, such that the flow rate decreases by an increment of about 2% over time. In other embodiments, the increment may be less than about 2% or more than about 2%. In some embodiments, the increment may be from about 0.5% to about 95%; about 1% to about 95%; about 2% to about 10%; about 1% to about 5%; about 5% to about 10%; about 5% to about 95%; about 10% to about 90%; about 15% to about 85%; about 20% to about 80%; about 25% to about 75%; about 30% to about 70%; about 35% to about 65%; about 40% to about 60%; about 45% to about 55%; about 45% to about 50%; etc. For example, the percent max water flow may decrease gradually over time. However, as shown in FIGS. 23A-23B, the overall water flow rate or percent may comprise a combination of flow from flow inlet valves in an inner region and flow inlet valves in an outer region. For example, as water flow into the mold from the inner region inlet valves increases over time, water flow into the mold from the outer region inlet valves decreases over time. This is exemplified in the graph of FIG. 23B, which shows the intersection between the decreasing outer region water flow and the increasing inner region water flow. For example, the intersection point may be characterized by equal or substantially equal water flow from the inner region and outer region inlet valves (e.g., about 50% of max coming from inner region and about 50% of max coming from outer region). As shown in FIG. 23A, flow through the inlet valves in the inner region increases incrementally over time. For example, the increment may be about 0.25% to about 5%; about 0.5% to about 5%; about 0.75% to about 5%; about 0.5% to about 4%; about 0.5% to about 3%; about 1% to about 3%; about 1.5% to about 2.5%; about 1% to about 50%; about 2% to about 20%; etc. The water flow through the inlet valves in the inner region may start or begin at a flow of about 0% to about 50%; about 0% to about 25%; about 5% to about 20%; about 10% to about 20%; about 5% to about 15%; about 8% to about 12%; etc. As shown in FIG. 23A, flow through the inlet valves in the outer region decreases incrementally over time. For example, the increment may be about 0.25% to about 5%; about 0.5% to about 5%; about 0.75% to about 5%; about 0.5% to about 4%; about 0.5% to about 3%; about 1% to about 3%; about 1.5% to about 2.5%; about 1% to about 50%; about 2% to about 20%; etc. The water flow through the inlet valves in the outer region may start or begin at a flow of about 50% to about 100%; about 50% to about 95%; about 60% to about 95%; about 70% to about 95%; about 80% to about 95%; about 90% to about 95%; about 85% to about 95%; about 88% to about 93%; etc. Alternatively, water flow through the inner region inlet valves may decrease over time and the water flow through the outer region inlet valves may increase over time. Alternatively still, the water flow through the inner region inlet valves may stay constant or fixed while the water flow through the outer region inlet valves increases or decreases over time. Alternatively still, the water flow through the outer region inlet valves may stay constant or fixed while the water flow through the inner region inlet valves increases or decreases over time.

[0137] FIGS. 24A-24B show a method of making clear ice. The method of FIGS. 24A-24B are similar to that shown in FIGS. 22A-22B, except that instead of the percent max water flow decreasing incrementally over time, the method of FIGS. 24A-24B include an incremental decrease in water

flow over time followed by a period of water flow reversal. Flow reversal means that inlet valves switch to outlet valves and/or outlet valves switch to inlet valves. As shown in FIGS. 24A-24B, the percentage max water flow incrementally decreases over time. For example, the increment may be between about 1% to about 10%; about 1% to about 8%; about 1% to about 6%; about 1% to about 4%; about 2% to about 4%; about 2% to about 5%; etc. for about 50 minutes to about 180 minutes; about 60 minutes to about 170 minutes; about 70 minutes to about 160 minutes; about 70 minutes to about 160 minutes; about 80 minutes to about 150 minutes; about 100 minutes to about 150 minutes; about 125 minutes to about 145 minutes; about 130 minutes to about 140 minutes; etc. A starting water flow percent may be between about 100% to about 50%; about 90% to about 50%; about 80% to about 60%; about 100% to about 90%; etc. An end water flow percent may be between about 0% to about 50%; about 5% to about 45%; about 10% to about 40%; about 15% to about 35%; about 20% to about 30%; about 20% to about 25%; etc. This period of positive flow may be followed by a period of flow reversal as described above. In this embodiment, water flow may be reversed that the fluid inlet valve becomes a fluid outlet valve, such that the water flow percent represents a flow of liquid out of the elongate trough. For example, reversed water flow may occur at between about 0% to about 50%; about 5% to about 45%; about 10% to about 40%; about 15% to about 35%; about 20% to about 35%; about 25% to about 35% about 28% to about 33% of max flow; etc. The period of water flow reversal may be between about 5 minutes to about 100 minutes; about 15 minutes to about 90 minutes; about 25 minutes to about 80 minutes; about 30 minutes to about 80 minutes; about 40 minutes to about 80 minutes; about 50 minutes to about 80 minutes; about 60 minutes to about 80 minutes; about 65 minutes to about 75 minutes; about 70 minutes to about 80 minutes; etc. In some embodiments, as shown in FIGS. 23A-23B, the annealing period may be characterized by a period of about 0% flow such that no liquid is coming into or out of the elongate trough. In other embodiments, the annealing period may be characterized by low water flow, for example 1% to about 10%; about 5% to about 15%; about 5% to about 10%; etc.

[0138] FIGS. 25A-25B show a method of making clear ice similar to a combination of the methods shown in FIGS. 23A-23B and FIGS. 24A-24B. In this embodiment, during the water flow reversal period, end plateau, and annealing phases, the water flow from the inlet valves has switch almost exclusively (i.e., 100%) to inner region flow from the inner region inlet valves. In other embodiments, water flow may switch almost exclusively (i.e., 100%) to outer region flow from the outer region inlet valves. Further, as shown in FIGS. 25A-25B, the intersection period, in which about 50% of water flow is from the inner region inlet valves and about 50% from the outer region inlet valves, has a time window of about 5 minutes to about 60 minutes; about 10 minutes to about 55 minutes; about 15 minutes to about 50 minutes; about 15 minutes to about 45 minutes; about 20 minutes to about 40 minutes; about 25 minutes to about 35 minutes; about 28 minutes to about 32 minutes; etc.

[0139] The methods of the preferred embodiment and variations thereof can be embodied and/or implemented at least in part as a machine configured to receive a computer-readable medium storing computer-readable instructions. The instructions are preferably executed by computer-ex-

executable components preferably integrated with the system and one or more portions of the processor on a computing device in communication with various components of the device for producing clear ice, such as but not limited to its various valves. The computer-readable medium can be stored on any suitable computer-readable media such as RAMs, ROMs, flash memory, EEPROMs, optical devices (e.g., CD or DVD), hard drives, floppy drives, or any suitable device. The computer-executable component is preferably a general or application-specific processor, but any suitable dedicated hardware or hardware/firmware combination can alternatively or additionally execute the instructions.

**[0140]** As used in the description and claims, the singular form “a”, “an” and “the” include both singular and plural references unless the context clearly dictates otherwise. For example, the term “trough” may include, and is contemplated to include, a plurality of troughs. At times, the claims and disclosure may include terms such as “a plurality,” “one or more,” or “at least one;” however, the absence of such terms is not intended to mean, and should not be interpreted to mean, that a plurality is not conceived.

**[0141]** The term “about” or “approximately,” when used before a numerical designation or range (e.g., to define a length or pressure), indicates approximations which may vary by (+) or (−) 5%, 1% or 0.1%. All numerical ranges provided herein are inclusive of the stated start and end numbers. The term “substantially” indicates mostly (i.e., greater than 50%) or essentially all of a device, substance, or composition.

**[0142]** As used herein, the term “comprising” or “comprises” is intended to mean that the devices, systems, and methods include the recited elements, and may additionally include any other elements. “Consisting essentially of” shall mean that the devices, systems, and methods include the recited elements and exclude other elements of essential significance to the combination for the stated purpose. Thus, a system or method consisting essentially of the elements as defined herein would not exclude other materials, features, or steps that do not materially affect the basic and novel characteristic(s) of the claimed disclosure. “Consisting of” shall mean that the devices, systems, and methods include the recited elements and exclude anything more than a trivial or inconsequential element or step. Embodiments defined by each of these transitional terms are within the scope of this disclosure.

**[0143]** The examples and illustrations included herein show, by way of illustration and not of limitation, specific embodiments in which the subject matter may be practiced. Other embodiments may be utilized and derived therefrom, such that structural and logical substitutions and changes may be made without departing from the scope of this disclosure. Such embodiments of the inventive subject matter may be referred to herein individually or collectively by the term “invention” merely for convenience and without intending to voluntarily limit the scope of this application to any single invention or inventive concept, if more than one is in fact disclosed. Thus, although specific embodiments have been illustrated and described herein, any arrangement calculated to achieve the same purpose may be substituted for the specific embodiments shown. This disclosure is intended to cover any and all adaptations or variations of various embodiments. Combinations of the above embodiments, and other embodiments not specifically described

herein, will be apparent to those of skill in the art upon reviewing the above description.

EXAMPLES

Example 10—Ice Formation as a Function of Cross-Sectional Shape of the Elongate Trough

**[0144]** As described above, the cross-sectional shape of the elongate trough can have an impact on both the clarity of clear ice formed as well as the time required of a freezing operation of the device to generate a particular volume of clear ice in many embodiments. Because heat flow through ice is directly proportional to  $1/W^2$  (wherein  $W$  is the distance to the center of the flume at a given height), the time required for the formation of a certain volume of ice can be approximated by the following Formula 1:

$$t = \frac{L_v W^2}{2K\Delta T} \tag{Formula 1}$$

**[0145]** Wherein  $L_v$  is the Latent Heat of Fusion of the liquid (e.g., water),  $K$  is the thermal conductivity of ice, and  $\Delta T$  is the temperature differential experienced across the medium in which heat is flowing.

**[0146]** Table 1 shows the difference in time required to grow an ingot of ice having a height of 85.0 mm in various elongate troughs, all having a semicircular base flume surface wall with a 3-inch diameter but with varying slopes of the side flume walls. Because they have an identical base flume surface wall, no difference is noted in the rate of ice formation until is growth expands onto the side flume surface walls. By the end of the ice formation process, the example with the greatest slope of its walls (an 8.5° angle) yields the slowest time for forming the last 5 mm increments of ice height, an additional 228 seconds over the example having vertical walls.

Example 11—Cracking Avoidance During Ice Formation—Stress Model I

**[0147]** In applying too great of a temperature differential across a length of a solid material, cracks can form in ice, which negatively affects the visual clarity of ice. For example, if one ramps the freezing temperature down too quickly, the newly frozen ice will form cracks as it suddenly freezes. Ramping the temperature down, however, can be quite valuable during a freezing operation of various ice makers, including embodiments of the device of FIG. 1 as described herein, in order to overcome the inherent insulating properties of the accumulating ice. In many embodiments, ramping down the temperature of the surface for ice generation such as a flume surface wall of the device described herein can be necessary to generate a sizable ingot of ice in a freezing operation having a duration of twelve hours or less.

**[0148]** Therefore, for the generation of a high-quality clear ice product, this stress must be avoided during the ice formation process. The stress ( $\sigma$ ) experienced by ice can be calculated by the following Formula 2:

$$\sigma = \alpha E \Delta T \tag{Formula 2}$$

**[0149]** Wherein  $\alpha$  is the coefficient of thermal expansion for ice ( $5.0 \times 10^{-5} \text{ } ^\circ\text{C}^{-1}$ ),  $E$  is Young’s modulus, and  $\Delta T$  is

the temperature differential experienced across the medium in which heat is flowing. Empirically, it is known that ice can withstand about 1 MPa of stress under this calculation before cracking.

**[0150]** However, as long as the conditions are not so stressful as to crack the ice, the ice naturally “relaxes” over time and reduces its experienced stress (this process is also known as creep, where solids materials near their melting point undergo physical deformations; this reduces the likelihood of cracking). The time  $t_\lambda$  required to relax a proportion of stress  $\lambda$  (the relaxation factor) from a material can be calculated by the following Formula 3:

$$t_\lambda = \frac{(\lambda^{1-n} - 1)\sigma(0)^{1-n}}{(n-1)A_0 E e^{-Q/RT}} \tag{Formula 3}$$

**[0151]** Wherein  $n$  is a first material constant for ice (a value of 3, unitless),  $A_0$  is a second material constant for ice ( $1.36 \times 10^9 \text{ MPa}^{-3} \text{ s}^{-1}$ ),  $\sigma$  is the starting stress of the material in MPa,  $E$  is Young’s Modulus,  $Q$  is the activation energy ( $78,000 \text{ Jmol}^{-1} \text{ K}^{-1}$ ),  $R$  is the universal gas constant, and  $T$  is the absolute temperature. Ice accumulation and relaxation can occur simultaneously as long as the experienced conditions do not apply a stress greater than 1 MPa at any point during the cycle. Therefore, the temperature of a cold surface for the generation of ice, such as a flume surface wall, can be ramped down as long as its schedule allows for sufficient relaxation against the gaining stress.

**[0152]** Table 2 depicts one embodiment of such a temperature schedule for a linear accumulation of ice in one dimension that is orthogonal to a cold surface that additionally takes into account the insulating properties of ice (see Example 1 and various discussions herein). The starting conditions and time were experimentally determined as to reasonably approach the 1 MPa maximum stress, but each subsequent temperature step and duration thereat were calculated by the above formulae such that sufficient relaxation could occur at a pace that allowed the total stress to remain just under about 1 MPa. This thereby can maximize the rate of ice accumulation while preserving a clarity unblemished with cracks. By this model, about 5.5 cm of clear ice can be generated in 198 minutes without cracking.

Example 12—Cracking Avoidance During Ice Formation—Stress Model II

**[0153]** Because the accumulation of clear ice within an elongate trough of the device as described herein generally occurs in a multidirectional manner (e.g., FIG. 2), a second stress model was generated by applying the principles of above Example 2 to the dimensions of one embodiment of an elongate trough and approximating the surface area of heat transfer with that of a pipe (ignoring the end caps). This cylindrical approximation requires the use of a log mean cross sectional area (see Formula 4) within Fourier’s Law of Heat Exchange (see Formula 5) because of the changing radius as accumulates and its effects on surface area available for heat exchange.

$$A_{lm} = \frac{A_{outer} - A_{inner}}{\ln\left(\frac{A_{outer}}{A_{inner}}\right)} \tag{Formula 4}$$

**[0154]** Wherein  $A_{outer}$  is the surface area of the outer cylindrical surface and  $A_{inner}$  is the surface area of the inner cylindrical surface. The surface area of a cylindrical shape can be calculated by  $A=2\pi rL$  wherein  $r$  is the radius of the cylinder and  $L$  is the length of the cylinder.

$$\dot{Q} = kA\left(\frac{\Delta T}{\Delta r}\right) \tag{Formula 5}$$

**[0155]** Wherein  $k$  is the thermal conductivity of the material,  $A$  is  $A_{lm}$ ,  $\Delta T$  is the change in temperature across the system, and  $\Delta r$  is the change in radius for the cylinder.

**[0156]** Table 3 presents an example temperature ramp schedule for ice formation that allows for sufficient relaxation in order to maintain the total stress on the ice under 1 MPa. In this embodiment, the elongate trough was 72 inches (about 1829 mm) long, a height of 3.5 inches (about 88.9 mm), a semicircular bottom having a radius of 1.5 inches (about 38.1 mm) and wherein the side walls had a slope of 2° off vertical (e.g., FIG. 3C). The model was run out to about 40 mm of accumulated ice thickness wherein the elongate trough would reach approximately maximum ice formation within its defined volume. As depicted, the presented temperature schedule can produce the approximately 40 mm of ice needed to fill the exemplary elongate trough in about 2 hours without cracking.

**1-64.** (canceled)

**65.** A device for making clear ice comprising:

at least one housing comprising at least one flume surface wall that defines at least one elongate trough;

at least one fluid intake disposed to provide a flow of fluid into the at least one elongate trough; and

at least one drain disposed to drain fluid from the at least one elongate trough,

wherein at least a portion of the at least one flume surface wall is in thermal communication with a cooling source,

wherein the at least one fluid intake and the at least one drain are configured to provide a substantially constant flow of fluid to the at least one elongate trough during a freezing operation of the device,

wherein the at least one fluid intake comprises a fluid intake manifold that defines an intake manifold cavity that is fluidly connected to the at least one elongate trough through a fluid entry portal.

**66.** The device of claim 65, wherein the cooling source is selected from the group consisting of: an internal cooling cavity defined by the housing, an evaporator, a cold plate, and a condenser.

**67.** The device of claim 65, wherein the at least one elongate trough has a total depth divided into an ice-forming zone and a fluid overflow zone, and wherein a surface area of the flume surface wall at least coextensive with the fluid overflow zone and comprises a thermally insulating material.

**68.** The device of claim 65, wherein the drain comprises a drain manifold that defines a single drain manifold cavity that is fluidly connected to the at least one elongate trough through a fluid exit portal of the at least one elongate trough.

**69.** The device of claim 68, wherein the drain manifold further comprises a drain flow divider insert having a porosity of about 10% open area to about 50% open area within the drain manifold cavity.

70. The device of claim 69, wherein the drain flow divider insert forms an arcuate shape and is coupled to adjacent corners of the drain manifold cavity, thereby dividing the drain manifold cavity into a first portion and a second portion, wherein at least one drainage pipe is in fluid communication with the first portion, and wherein the fluid exit portal is in fluid communication with the second portion.

71. The device of claim 65, wherein the substantially constant flow of fluid is provided at a velocity of at least about 0.09 m/s (about 0.3 ft/s) through the at least one elongate trough.

72. The device of claim 65, wherein the substantially constant flow of fluid has a velocity of at least about 0.21 m/s (about 0.7 ft/s) through the at least one elongate trough.

73. The device of claim 65, further comprising at least one lid configured to enclose the at least one elongate trough when the at least one trough is removably coupled to the housing.

74. The device of claim 65, further comprising one or more retractable inclusion holders configured to be disposed within a cavity defined by the at least one elongate trough.

75. A method for manufacturing clear ice comprising: providing a device for making clear ice comprising:  
 a housing comprising at least one flume surface wall that defines at least one elongate trough;  
 a fluid intake disposed to provide a flow of fluid into the at least one elongate trough;  
 a drain disposed to drain fluid from the at least one elongate trough;  
 wherein at least a portion of the at least one flume surface wall is in thermal communication with a cooling source;  
 wherein the fluid intake and the drain are configured to provide a substantially constant flow of fluid to the at least one elongate trough during a freezing operation of the device, the fluid intake comprising a fluid intake manifold that defines a single intake manifold cavity that is fluidly connected to the at least one elongate trough through a fluid entry portal;

providing a substantially constant flow of fluid down the at least one elongate trough via the fluid intake and the drain; and

cooling the at least one flume surface wall to a temperature of less than or equal to about 0 degrees Celsius.

76. The method of claim 75, wherein the cooling source is selected from the group consisting of: an internal cooling cavity defined by the housing, an evaporator, a cold plate, and a condenser.

77. The method of claim 75, wherein the device for making clear ice further comprises:

one or more inclusion holders configured to be disposed within the at least one elongate trough and retracted in

response to a predefined level of ice accumulation within a cavity defined by the at least one elongate trough.

78. The method of claim 77, further comprising: securing an item with the one or more inclusion holders such that the item is positioned within a cavity defined by the at least one elongate trough; and retracting the one or more inclusion holders after a sufficient accumulation of ice within the at least one elongate trough such that the item remains at least partially embedded in the accumulation of ice upon retraction of the one or more inclusion holders.

79. The method of claim 75, wherein the substantially constant flow of fluid down the at least one elongate trough has a velocity of at least about 0.09 m/s (about 0.3 ft/s) through the at least one elongate trough.

80. The method of claim 75, wherein the substantially constant flow of fluid has a velocity of at least about 0.21 m/s (about 0.7 ft/s) through the at least one elongate trough.

81. A device for making clear ice comprising:  
 at least one housing defining a plurality of elongate troughs;  
 at least one fluid intake disposed to provide a flow of fluid into the plurality of elongate troughs; and  
 at least one drain disposed to drain fluid from the plurality of elongate troughs,

wherein at least a portion of an exterior of each of the plurality of elongate troughs is in thermal communication with a cooling source,

wherein the at least one fluid intake and the at least one drain are configured to provide a substantially constant flow of fluid to the plurality of elongate troughs during a freezing operation of the device,

wherein the fluid intake comprises a fluid intake manifold that defines an intake manifold cavity that is fluidly connected to each of the plurality of elongate troughs through a plurality of fluid entry portals.

82. The device of claim 81, wherein the cooling source is selected from the group consisting of: an internal cooling cavity defined by the housing, an evaporator, a cold plate, and a condenser.

83. The device of claim 81, wherein each of the plurality of elongate troughs has a total depth divided into an ice-forming zone and a fluid overflow zone, and wherein a portion of an internal surface of each of the plurality of elongate troughs is at least coextensive with the fluid overflow zone and comprises a thermally insulating material.

84. The device of claim 81, wherein plurality of elongate troughs comprises at least four troughs arranged substantially in parallel and in a side by side arrangement.

85. The device of claim 81, wherein the substantially constant flow of fluid is provided at a velocity of at least about 0.09 m/s (about 0.3 ft/s) through the at least one elongate trough.

\* \* \* \* \*