



(22) **Date de dépôt/Filing Date:** 2011/08/16

(41) **Mise à la disp. pub./Open to Public Insp.:** 2013/02/16

(45) **Date de délivrance/Issue Date:** 2018/09/25

(51) **Cl.Int./Int.Cl. B65D 50/00** (2006.01),
B65D 43/02 (2006.01), **B65D 55/02** (2006.01)

(72) **Inventeur/Inventor:**
NIKAEIN, BEHDOKHT, CA

(73) **Propriétaire/Owner:**
BN PROGRESSIVE PRODUCTS LTD., CA

(74) **Agent:** DEETH WILLIAMS WALL LLP

(54) **Titre : CONTENANT INVOLABLE**

(54) **Title: TAMPER-EVIDENT CONTAINER**

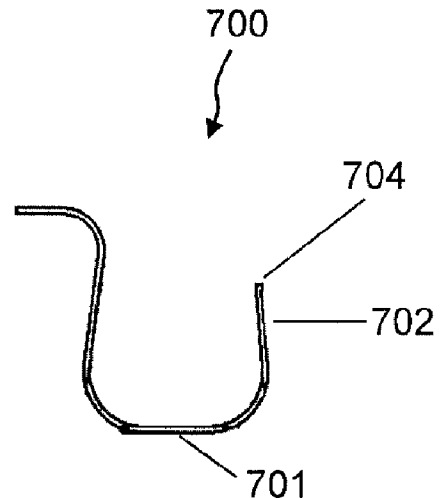
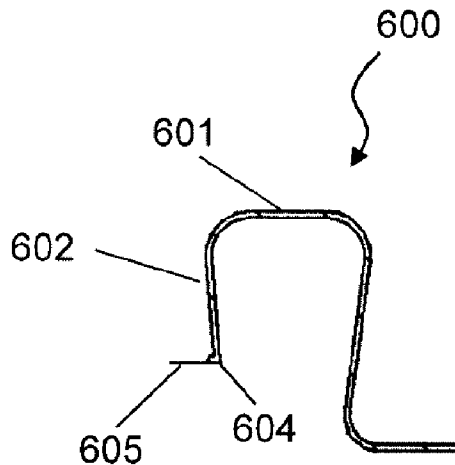

(57) **Abrégé/Abstract:**

The present invention is a tamper-resistant and tamper-evident container for holding solid and liquid goods, such as food items. The container has a base portion with a male member extending upwardly from the base and extending about an opening in the base, the outer surface of the male member having a guard lip extending outwardly. The container has a cover with a female member extending upwardly for frictionally engaging the male member when the container is closed. The guard lip renders the lower edge of the outer portion of the female member relatively inaccessible. The container has a hinge connecting the cover to the base having a removable portion that may be removed to facilitate opening the container.

ABSTRACT

The present invention is a tamper-resistant and tamper-evident container for holding solid and liquid goods, such as food items. The container has a base portion with a male member extending upwardly from the base and extending about an opening in the base, the outer surface of the male member having a guard lip extending outwardly. The
5 container has a cover with a female member extending upwardly for frictionally engaging the male member when the container is closed. The guard lip renders the lower edge of the outer portion of the female member relatively inaccessible. The container has a hinge connecting the cover to the base having a removable portion that may be removed to
10 facilitate opening the container.

TAMPER-EVIDENT CONTAINER

FIELD OF THE INVENTION

[0001] The present invention relates generally to containers, and more particularly to
5 containers that are resistant to opening without leaving evidence that they have been opened.

BACKGROUND OF THE INVENTION

[0002] Containers are widely used in the consumer products industry to hold consumable
products such as food items, for example, strawberries and cookies, and items such as screws
and pins. Such items are often relatively small and sold in batches. For example, a container
10 of strawberries may contain 25 strawberries and a container of screws may contain 200
screws. Containers containing such goods are displayed in retail stores where consumers can
view and inspect them, and typically place them into a shopping cart should a consumer
choose to purchase a container of such goods.

[0003] Such containers are typically constructed from transparent plastic so that consumers
15 can see the goods without opening the container. Allowing consumers to open a container
prior to purchasing it can raise several issues. If a consumer knows that other consumers are
able to open and touch or remove items, then the consumer is likely to be concerned that
some items may have been removed or, in the case of food particularly, that the items have
been touched in an unsanitary manner or in a manner that may otherwise make the goods less
20 desirable or useful. Vendors are similarly concerned that such tampering with goods may
dissuade consumers from purchasing containers of such items and that they may incur
liability if tampering has occurred that may endanger a purchaser or make the items in the
container incompatible with the terms of sale, particularly if a container may be opened and
re-sealed without leaving evidence of such actions. Thus both consumers and vendors have
25 an interest in goods being sold in containers that are resistant to such tampering, or at least
are designed to leave clear evidence of such tampering after it occurs.

[0004] Thermoformed plastic containers are in wide use for consumer goods. In some cases,
the container is formed so that it is permanently sealed and can only be opened by cutting or
tearing the plastic. While this approach results in clear evidence of tampering, it also means

that the package is not re-sealable. It is often highly desirable for such containers to be re-sealable so that a consumer can remove some items from the container and leave the remaining items in the container for future use. If the container cannot be re-sealed, then the remaining items are more likely to be accidentally lost, or be spoiled. For a food container, it is generally very desirable that the container can be re-sealed to minimize the exposure of the contents to ambient air which can result in food spoiling more quickly than it would if it were isolated from such ambient air.

SUMMARY OF THE INVENTION

10 [0005] The present invention provides a container having:

- 15 a. a base portion defining an interior space for holding solid or liquid goods, the interior space having an upwardly facing opening having a perimeter, the base portion having an upwardly projecting male member extending substantially about the perimeter of the opening, the male member having a top and having inner and outer surfaces extending downward from the top, each surface having a height, the outer surface of the male member having a guard lip extending outwardly below the top of the male member, the guard lip extending substantially about the perimeter of the opening;
- 20 b. a cover portion having a perimeter and a female member extending substantially about the perimeter of the cover portion, the female member having a top and having inner and outer portions extending downward from the top for frictionally engaging the inner and outer surfaces of the male member respectively to form a seal when the container is closed, each portion having a height, the outer portion of the female member having a lower edge, wherein, when the container is closed, the guard lip renders the lower edge of the outer portion of the female member relatively inaccessible; and
- 25 c. a hinge connecting the outer portion of the female member to the outer surface of the male member, the hinge having a portion that is removable to facilitate opening the container.

[0006] Removing the removable portion of the hinge may expose a tab attached to the outer portion of the female member, the tab being adapted for facilitating removal of the cover portion from the base portion when the container is closed.

5 [0007] The outer surface of the male member may have a lower edge and the guard lip may extend outwardly from the lower edge of the outer surface of the male member.

[0008] The guard lip may have an outer edge and have a shield projecting upwardly from the outer edge, the upwardly projecting shield extending substantially about the perimeter of the opening.

10 [0009] The cover portion may further comprise a flange extending outwardly from the lower edge of the outer portion of the female member and extending substantially about the perimeter of the cover portion, the flange having a width, wherein the guard lip has a width greater than or equal to the width of the flange, and the height of the outer portion of the female member is greater than or equal to the height of the outer surface of the male member so that the flange abuts the guard lip when the container is closed. The guard lip may have an
15 outer edge and have a shield projecting upwardly from the outer edge, the upwardly projecting shield extending substantially about the perimeter of the opening, wherein, when the container is closed, the upwardly projecting shield renders the flange relatively inaccessible. The flange may have an outer edge, and the flange may have sufficient width so that, when the container is closed, the outer edge of the flange abuts the upwardly projecting
20 shield.

[0010] The hinge may connect the lower edge of the outer portion of the female member to the lower edge of the outer surface of the male member so that the hinge is substantially horizontally oriented when the container is closed.

25 [0011] The male and female members may extend completely about the perimeter of the opening and the perimeter of the cover portion respectively.

[0012] The outer surface of the male member and the outer portion of the female member may be substantially vertical and the guard lip may extend substantially horizontally from the outer surface of the male member. The inner surface of the male member and the outer portion of the female member may be substantially vertical.

[0013] The height of the outer portion of the female member may be greater than or equal to the height of the outer surface of the male member so that the lower edge of the outer portion of the female member abuts the guard lip when the container is closed.

5 [0014] The outer surface of the male member and the outer portion of the female member may have approximately equal heights so that the top of the male member abuts the top of the female member when the container is closed.

BRIEF DESCRIPTION OF THE DRAWINGS

[0015] Figure 1 is a perspective view of a closed container.

10 [0016] Figure 2 is a perspective view of an open container.

[0017] Figure 3 is a side view of an open container.

[0018] Figure 4 is a cross-section through the circled portion marked as 4 in Figure 3 showing a male member having an upwardly projecting shield.

15 [0019] Figure 5 is a cross-section through the circled portion marked as 5 in Figure 3 showing an upside-down female member having a flange.

[0020] Figure 6 is a cross section through a male member of an embodiment with no upwardly projecting shield.

[0021] Figure 7 is a cross section through an upside-down female member of an embodiment with no flange.

20 [0022] Figure 8 is a side view of a closed container.

[0023] Figure 9 is a top view of an open container.

[0024] Figure 10 is a perspective view of another embodiment of a closed container.

DETAILED DESCRIPTION

25 [0025] One embodiment of the invention is shown in Figures 1-3, 8 and 9 which depict a tamper-evident, or tamper-resistant, container 100 adapted for holding solid or liquid goods, such as fruit or nails. A second embodiment 1000 is shown in Figure 10. The container 100

has a base portion 102 that defines an interior space for holding the solid or liquid goods. The base portion 102 generally has a bottom and walls extending upwardly therefrom to form the interior space. In the depicted embodiment, four walls are used in a rectangular arrangement where the four walls are connected by rounded corners. Many variations are possible. For
5 example, the walls could have a circular or oval horizontal cross-section parallel to the bottom.

[0026] In this document, “horizontal”, “vertical”, “upward”, “downward”, “higher” and variations thereof are used to refer to the orientation of portions of the container 100, 1000, or cross-sections thereof, when the container is placed on a horizontal flat surface in a closed
10 configuration with the bottom of the base portion 102 in contact with the flat surface, which is the orientation shown in Figure 8.

[0027] The base portion 102 has an upwardly facing opening 202 that can be seen in Figure 2. The opening allows goods to be placed into and removed from the interior space. In a typical embodiment, as depicted in Figure 2, the opening is rectangular and extends between
15 four walls. The walls are generally substantially vertical or outwardly sloping so that the opening 202 is approximately equal to or larger in area than the bottom of the container 100. In other embodiments, the opening may be circular or oval, particularly where the walls are in a circular or oval configuration (i.e. when horizontal cross-sections parallel to the bottom of the container 100 are circular or oval). The opening 202 is preferably parallel to the
20 bottom of the container 100 and higher than any point within the interior space, although this is not essential.

[0028] It is not necessary that the opening 202 extend out to vertical or outwardly sloping walls as shown in the depicted embodiment. For example, a container 100 adapted for
25 holding liquids may employ a smaller opening with an area smaller than that of the bottom of the base portion 102. In that case, the base may include a top portion extending horizontally from the side walls, the top portion defining the opening. In other embodiments, the base 102 may have no flat surfaces, but generally has a bottom portion adapted to be placed on a flat surface and maintain the container 100 in a fixed position. This may be achieved by having a flat bottom, although the upper surface of the bottom may be convex so that only the edges of
30 the bottom contact the flat surface on which the container 100 is placed.

[0029] The base portion 102 is generally constructed so that, when the container is resting on a flat surface with its bottom portion contacting the flat surface, the opening 202 is upwardly facing and the perimeter of the opening is substantially in a horizontal plane parallel to the flat surface. This configuration is preferred particularly for containers 100 adapted to hold liquid goods.

[0030] The container 100 has a cover portion 101 that is connected to the base portion 102 by a hinge 103. The hinge allows the cover portion 102 to be moved from an open position as shown in Figure 2 to a closed position as shown in Figure 1. The cover portion 101 is generally flat with a female member 104 extending substantially, and usually completely, about the perimeter of the cover portion. It is generally preferred, but is not essential, that the cover portion 101, other than the female member 104, be flat so, for example, containers 100 may be readily stacked. In some embodiments the upper surface of the cover portion 101 may be, for example, convex, which effectively increases the usable volume of the interior space for certain types of solid goods.

[0031] The base portion 102 has a male member 200 extending substantially, and usually completely, about the perimeter of the opening. Example embodiments of the male member 200 and female member 104 are depicted in Figures 3-5. The male member 200 has a top 400, and inner and outer surfaces 402, 401 extending downward from the top 400. In the embodiment depicted, there is space between the inner and outer surfaces 402, 401, but this is not essential. For example, the male member 200 may be solid, in which case the width of the male member 200, being the distance between the inner surface 402 and the outer surface 401, is generally relatively small.

[0032] The female member 104 has a top 500 and inner and outer portions 502, 501 extending downward from the top 500. The width of the female member 104, being the distance between outer surfaces of the inner portion 502 and the outer portion 501, is approximately equal to the width of the male member 200 so that the inner and outer portions, 502, 501 of the female member 104 frictionally engage the outer surfaces of the inner and outer portions 402, 401 when the container 100 is closed, as depicted in Figures 1 and 8. The engagement of the female member 104 with the male member 200 forms a seal that maintains the container 100 in a closed position and may reduce the intermixing of air

inside the container 100 in the interior space with air outside the container 100. This is particularly useful for containers 100 adapted to hold food items.

[0033] The hinge has a lower portion 201 connected along a first tear line 103, which is straight, to a removable upper portion 105. The portions are connected so that they may
5 rotate around the axis defined by the first tear line 103, so that the cover portion 101 may be moved from an open position to a closed position. The removable portion 105 is connected along a second tear line 107 to a flange 108 extending from the outer portion 501 of the female member 104. The tear line 107 is generally formed so that the flange 108 has one or more tabs 106 that extend outwardly after the removable portion 105 is removed for
10 facilitating opening the container 100. For example, after the removable portion 105 is removed, a person may grasp a tab 106 between two fingers and pull it upwardly while holding the base portion 102 to remove the cover portion 101 from the base portion 102, thereby opening the container 100. In other embodiments, the tabs 106 may extend directly from the outer portion 501 of the female member 104 and the second tear line 107 be
15 between the removable portion 105 and the outer portion 501 of the female member 104 other than in those places where the one or more tabs 106 extend.

[0034] When a container 100 is manufactured it is generally formed in the open position as shown in Figures 2, 3 and 9 so that the cover portion 101 is upside-down relative to its closed position. This facilitates stacking open containers 100. Goods may then be placed into the
20 interior space of a container 100 and the container closed by rotating the cover portion 101 about the axis defined by the first tear line 103 of the hinge until the female member 104 of the cover portion 101 meets the male member 200 of the base portion 102, the size and location of the female member 104 and male portion 200 being selected to ensure they mate to form a seal. Pressure can then be applied downward on the female member to overcome
25 the friction between the inner and outer portions, 502, 501 of the female member 104 and the inner and outer surfaces 402, 401 of the male member 200 so that the container 100 is placed in a closed position as shown in Figure 8.

[0035] The container 100 may then be opened by removing the removable portion 105 of the hinge, for example by grasping it between two fingers and pulling it up so as to rupture the
30 tear lines 103, 107 and expose the one or more tabs 106 on the cover portion that facilitate

removal of the cover portion from the base portion 102. The detached cover portion 101 can readily be placed back in frictional contact with the base portion 102 so that it is re-sealed by placing it on top of the opening and applying pressure downward to re-engage the male and female members 200, 104. In this manner, the container 100 may be opened and closed to re-
5 seal it multiple times as goods stored in the interior space are consumed.

[0036] The base portion 102 further includes a guard lip 404, 605 as shown in two embodiments of the male member 200, 600 in Figures 4 and 6. The guard lip 404, 605 extends outwardly from the outer surface 401, 602 of the male member 200, 600 below the top 400, 601 of the male member 200, 600 and extends substantially or completely about the
10 opening 202. When the container 100 is closed, as shown in Figure 8, the guard lip 404, 605 renders the lower edge 704, 503 of the outer portion of the female member relatively inaccessible so that it is difficult for a person to grasp the edge to open the container 100. Generally a person wanting to open the container 100 must remove the removable portion 105 of the hinge as described above, thereby leaving clear evidence, by rupturing the tear
15 lines, that the container 100 may have been opened so that the contents may have been tampered with.

[0037] In the embodiment shown in Figure 7, the outer portion 702 of the female member 700 may be substantially vertical and terminate at the lower edge 704. In another embodiment shown in Figure 5, the outer portion 501 of the female member 104 may have a
20 flange 504 extending from the lower edge 503 of the outer portion 501 of the female member 104. The inner and outer portions 502, 501 of the female member 104 are designed so that they frictionally engage the inner and outer surfaces 402, 401 of the male member 200 respectively. This may be achieved as shown in Figures 4-7 by making the inner and outer portions 502, 501 of the female member 104 and the inner and outer surfaces 402, 401 of the
25 male member 200 substantially vertical and approximately the same width, and the tops 400, 500 substantially flat. When the material used to make the container 100 is flexible, it may be advantageous for the inner and outer portions 502, 501 of the female member 104 and the inner and outer surfaces 402, 401 of the male member 200 to be slightly sloped, as shown in Figures 4-7, so that the width of the members 200, 104 is slightly greater near the top 400,
30 500 than near the lower edge 403 of the outer surface 401 of the male member 200 and the

lower edge 503 of the outer portion 501 of the female member 104 in order to form a better seal.

[0038] In the depicted embodiments, the tops 400, 500 of the members 200, 104 are flat and connect to the inner and outer portions 502, 501 of the female member 104 and inner and outer surfaces 402, 401 of the male member 200 via a rounded portion, but this is not essential. For example the tops 400, 500 could be rounded or the inner and outer portions 502, 501 of the female member 104 and inner and outer surfaces 402, 401 of the male member 200 may be substantially perpendicular to the tops 400, 500, connecting at a sharp edge.

[0039] The guard lip 404, 605 may extend from the lower edge 403, 604 of the outer surface 401 of the male member 200, 600 as shown in Figures 4 and 6, or it may extend from another point below the top 400, 601. In a preferred embodiment, the height of the outer portion 501, 702 of the female member 104, 700, the height being the vertical distance between the top 500, 701 and the lower edge 503, 704 of the female member 104, 700, is selected to be greater than or equal to the height of the outer portion 401, 602 of the male member 200, 600, the height being the vertical distance between the top 400, 601 and the lower edge 403, 604 of the male member 200, 600. In this case, the lower edge 503, 704 of the female member 104, 700 abuts the guard lip 404, 605 when the container 100 is closed. In some embodiments, the height of the outer portion 501, 702 of the female member 104, 700 is selected to be approximately equal to the height of the outer portion 401, 602 of the male member 200, 600. In this case, the lower edge 503, 704 of the female member 104, 700 abuts the guard lip 404, 605 and the top 400, 601 of the male member 200, 600, abuts the top 500, 701 of the female member 104, 700.

[0040] In some embodiments, the guard lip 404, 605 may also have a raised portion projecting upwardly from the outer edge of the guard lip 404, 605, which may be referred to as an upwardly projecting shield 405. Having an upwardly projecting shield 405 may further render the lower edge 704 of the outer portion 702 of the female member 700 relatively inaccessible when the container 100 is closed, so that it is difficult to open the container 100 without tearing off the removable portion 105 of the hinge. The upwardly projecting shield 405 may project vertically from the outer edge of the guard lip 404, 605 either via a rounded

corner or by a sharp corner so that the point of contact between the upwardly projecting shield 405 and the outer edge of the guard lip 404, 605 forms a right angle. Alternatively the upwardly projecting shield 405 may be curved or sloped. The upwardly projecting shield 405 may further have a flange extending outwardly from its top edge.

5 [0041] In some embodiments, the female member 104 may have a flange 504 extending outwardly from its lower edge 503 of its outer portion 501. The flange 504 may extend substantially or completely about the perimeter of the cover portion 101 and preferably have a width that is less than or equal to the width of the guard lip 404, 605 so that the guard lip 404, 605 renders the flange 504 relatively inaccessible when the container 100 is closed. The
10 flange 504 and guard lip 404, 605 may both be horizontally oriented when closed. In this case, it is preferable that the height of the outer portion 501 of the female member 104 is selected to be greater than or equal to the height of the outer portion 401, 602 of the male member 200, 600 so that the flange 504 abuts the guard lip 404, 605 when the container 100 is closed.

15 [0042] In some embodiments employing an upwardly projecting shield 405 on the guard lip 404, a flange 504 may be formed on the female member 104 such that the width of the flange 504 is approximately equal to the width of the guard lip 404 so that the outer edge 505 of the flange 504 abuts the upwardly projecting shield 405 when the container is closed. This may further render the flange relatively inaccessible when the container 100 is closed. In such
20 embodiments, it is preferable that the height of the outer portion 501 of the female member 104 is selected to be greater than or equal to the height of the outer portion 401 of the male member 200 so that the flange 504 abuts the guard lip 404 when the container 100 is closed.

[0043] The tamper evident containers are thermoformed out of plug assist or cut in place thermoforming machines. In these processes, raw material first is heated to its soft point and
25 is sent to the forming station which will be formed by means of either heat or vacuum. Then, the web of formed parts is directed to a trim station and the formed parts are separated from the web. Raw material can be any type of plastic which is formable on a thermoforming machine, such as PET, OPS, PVC, PP, LDPE, HDPE.

[0044] As will be evident to those skilled in the art, an alternative embodiment could employ a female member on the base portion and a male member on the cover portion of a container. Such an embodiment would include, by analogy to the embodiment described above:

- 5 • a cover portion having an downwardly projecting male member extending substantially about the perimeter of the cover portion, the male member having a bottom and having inner and outer surfaces extending upward from the bottom, each surface having a height, the outer surface of the male member having a guard lip extending outwardly above the bottom of the male member, the guard lip extending substantially about the perimeter of the cover portion;
- 10 • a base portion defining an interior space for holding solid or liquid goods, the interior space having an upwardly facing opening having a perimeter, the base portion having a downwardly projecting female member extending substantially about the perimeter of the opening, the female member having a bottom and having inner and outer portions extending upward from the bottom for frictionally engaging the inner and
- 15 outer surfaces of the male member respectively to form a seal when the container is closed, each portion having a height, the outer portion of the female member having an upper edge, wherein, when the container is closed, the guard lip renders the upper edge of the outer portion of the female member relatively inaccessible; and
- 20 • a hinge connecting the outer portion of the female member to the outer surface of the male member, the hinge having a portion that is removable to facilitate opening the container.

[0045] In this alternative embodiment, removing the removable portion of the hinge may expose a tab attached to the outer portion of the male member, the tab being adapted for facilitating removal of the cover portion from the base portion when the container is closed.

- 25 [0046] In this alternative embodiment, the outer surface of the male member may have an upper edge and the guard lip may extend outwardly from the upper edge of the outer surface of the male member. The base portion may further include a flange extending outwardly from the upper edge of the outer portion of the female member and extending substantially about the perimeter of the opening, the flange having a width, wherein the guard lip has a
- 30 width greater than or equal to the width of the flange, and the height of the outer portion of

the female member is greater than or equal to the height of the outer surface of the male member so that the flange abuts the guard lip when the container is closed. The height of the outer portion of the female member may be greater than or equal to the height of the outer surface of the male member so that the upper edge of the outer portion of the female member
5 abuts the guard lip when the container is closed. The outer surface of the male member and the outer portion of the female member may have equal heights so that the bottom of the male member abuts the bottom of the female member when the container is closed.

[0047] In this alternative embodiment, the guard lip may have an outer edge and a shield projecting downwardly from the outer edge, the downwardly projecting shield extending
10 substantially about the perimeter of the cover

[0048] In this alternative embodiment, the guard lip may have an outer edge and a shield projecting downwardly from the outer edge, the downwardly projecting shield extending substantially about the perimeter of the cover, wherein, when the container is closed, the downwardly projecting shield renders the flange relatively inaccessible. The flange may have
15 an outer edge, and the flange may have sufficient width so that, when the container is closed, the outer edge of the flange abuts the downwardly projecting shield.

[0049] In this alternative embodiment, the outer surface of the male member may have an upper edge and the hinge may connect the upper edge of the outer portion of the female member to the upper edge of the outer surface of the male member so that the hinge is
20 substantially horizontally oriented when the container is closed.

[0050] In this alternative embodiment, the female and male members may extend completely about the perimeter of the opening and the perimeter of the cover portion respectively.

[0051] In this alternative embodiment, the outer surface of the male member and the outer portion of the female member may be substantially vertical and the guard lip may extend
25 substantially horizontally from the outer surface of the male member. The inner surface of the male member and the inner portion of the female member may be substantially vertical.

[0052] The scope of the claims that follow is not limited by the embodiments set forth in the description. The claims should be given the broadest purposive construction consistent with the description as a whole.

CLAIMS

What is claimed is:

1. A container comprising:
 - a. a base portion defining an interior space for holding solid or liquid goods, the interior space having an upwardly facing opening having a perimeter, the base portion having an upwardly projecting male member extending substantially about the perimeter of the opening, the male member having a top and having inner and outer surfaces extending downward from the top, each surface having a height, the outer surface of the male member having a guard lip extending horizontally outwardly below the top of the male member to an outer edge, the guard lip extending substantially about the perimeter of the opening, wherein the guard lip is flat and has no upwardly or downwardly members projecting from or attached to the outer edge of the guard lip;
 - b. a cover portion having a perimeter and a female member extending substantially about the perimeter of the cover portion, the female member having a top and having inner and outer portions extending downward from the top for frictionally engaging the inner and outer surfaces of the male member respectively to form a seal when the container is closed, each portion having a height, the outer portion of the female member having a lower edge, wherein, when the container is closed, the guard lip renders the lower edge of the outer portion of the female member relatively inaccessible; and
 - c. a hinge connecting the outer portion of the female member to the outer surface of the male member, the hinge having a portion that is removable to facilitate opening the container,

wherein the outer surface of the male member and the outer portion of the female member are substantially vertical and the guard lip extends substantially horizontally from the outer surface of the male member,

and wherein no portion of the cover portion extends outward beyond the substantially vertical outer portion of the female member,

and wherein the outer surface of the male member has a lower edge and the guard lip extends outwardly from the lower edge of the outer surface of the male member,

and wherein the height of the outer portion of the female member is approximately equal to the height of the outer surface of the male member so that the lower edge of the outer portion of the female member abuts the guard lip when the container is closed and the top of the male member abuts the top of the female member when the container is closed,

and wherein the outer portion of the female member contains no apertures or holes therethrough.

2. The container of claim 1 wherein removing the removable portion of the hinge exposes a tab attached to the outer portion of the female member, the tab being adapted for facilitating removal of the cover portion from the base portion when the container is closed.
3. The container of claim 1 wherein the hinge connects the lower edge of the outer portion of the female member to the lower edge of the outer surface of the male member so that the hinge is substantially horizontally oriented when the container is closed.
4. The container of claim 1 wherein the male and female members extend completely about the perimeter of the opening and the perimeter of the cover portion respectively.
5. The container of claim 1 wherein the inner surface of the male member and the inner portion of the female member are substantially vertical.
6. A container comprising:
 - a. a cover portion having an downwardly projecting male member extending substantially about the perimeter of the cover portion, the male member having a bottom and having inner and outer surfaces extending upward from the bottom, each surface having a height, the outer surface of the male member having a guard lip extending horizontally outwardly above the

bottom of the male member to an outer edge, the guard lip extending substantially about the perimeter of the cover portion, wherein the guard lip is flat and has no upwardly or downwardly members projecting from or attached to the outer edge of the guard lip;

- b. a base portion defining an interior space for holding solid or liquid goods, the interior space having an upwardly facing opening having a perimeter, the base portion having a downwardly projecting female member extending substantially about the perimeter of the opening, the female member having a bottom and having inner and outer portions extending upward from the bottom for frictionally engaging the inner and outer surfaces of the male member respectively to form a seal when the container is closed, each portion having a height, the outer portion of the female member having an upper edge, wherein, when the container is closed, the guard lip renders the upper edge of the outer portion of the female member relatively inaccessible; and
- c. a hinge connecting the outer portion of the female member to the outer surface of the male member, the hinge having a portion that is removable to facilitate opening the container,

wherein the outer surface of the male member and the outer portion of the female member are substantially vertical and the guard lip extends substantially horizontally from the outer surface of the male member,

and wherein no portion of the base portion extends outward beyond the substantially vertical outer portion of the female member,

and wherein no portion of the base portion extends outward beyond the horizontal guard lip on the male member,

and wherein the outer surface of the male member has an upper edge and the guard lip extends outwardly from the upper edge of the outer surface of the male member,

and wherein the height of the outer portion of the female member is approximately equal to the height of the outer surface of the male member so that

the upper edge of the outer portion of the female member abuts the guard lip when the container is closed and the bottom of the male member abuts the bottom of the female member when the container is closed,

and wherein the outer portion of the female member contains no apertures or holes therethrough.

7. The container of claim 6 wherein removing the removable portion of the hinge exposes a tab attached to the outer portion of the male member, the tab being adapted for facilitating removal of the cover portion from the base portion when the container is closed.
8. The container of claim 6 wherein the hinge connects the upper edge of the outer portion of the female member to the upper edge of the outer surface of the male member so that the hinge is substantially horizontally oriented when the container is closed.
9. The container of claim 6 wherein the female and male members extend completely about the perimeter of the opening and the perimeter of the cover portion respectively.
10. The container of claim 6 wherein the inner surface of the male member and the inner portion of the female member are substantially vertical.

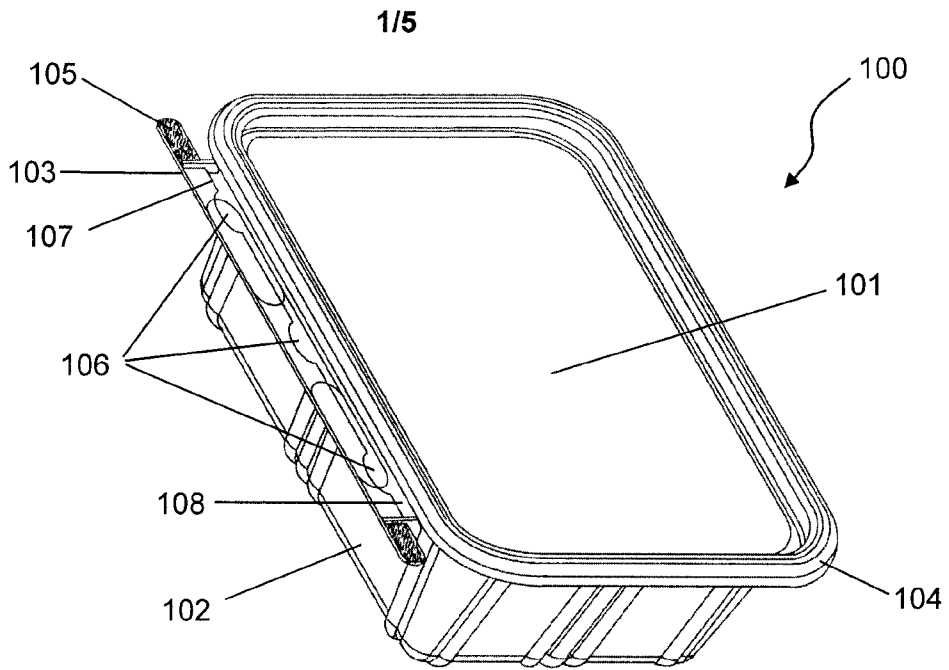

Fig. 1

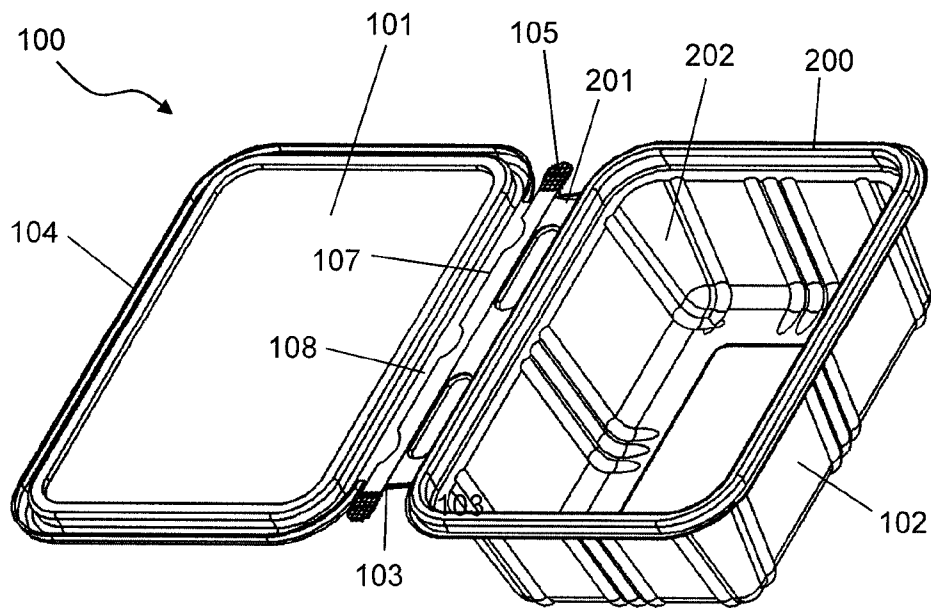

Fig. 2

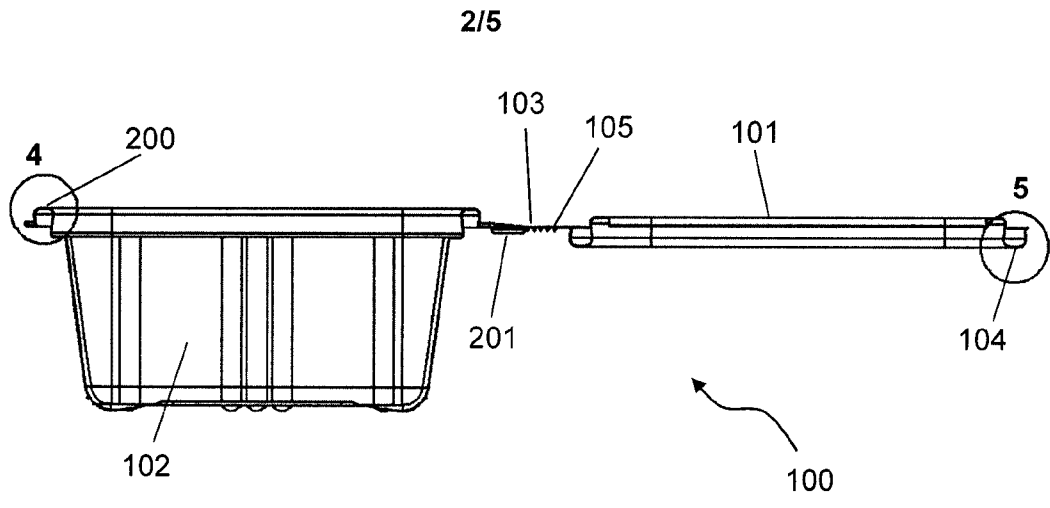

Fig. 3

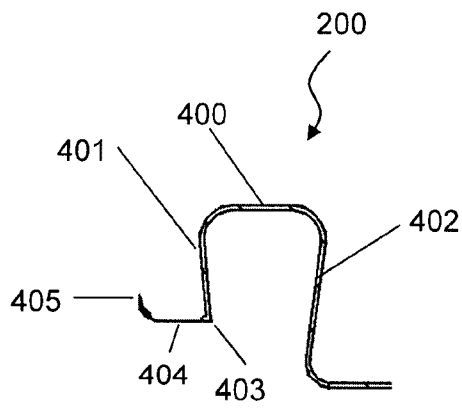

Fig. 4

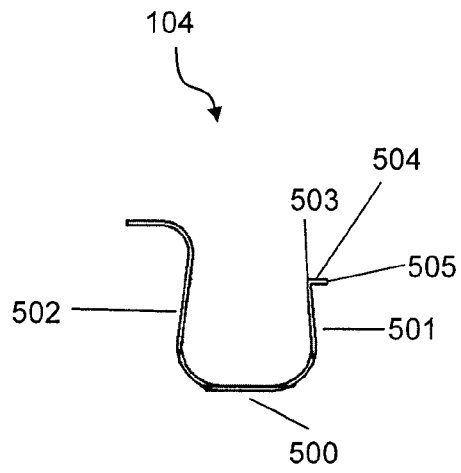

Fig. 5

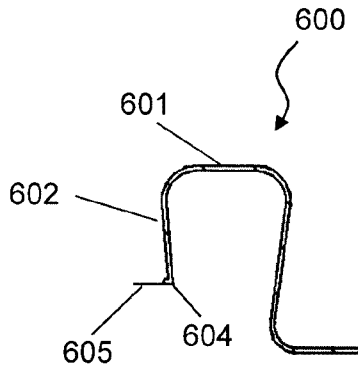

Fig. 6

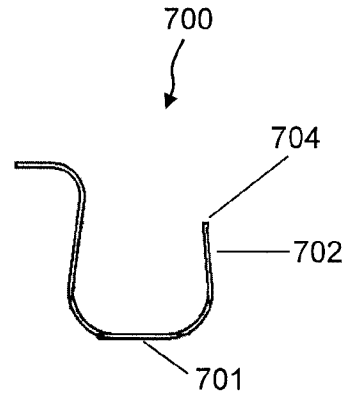

Fig. 7

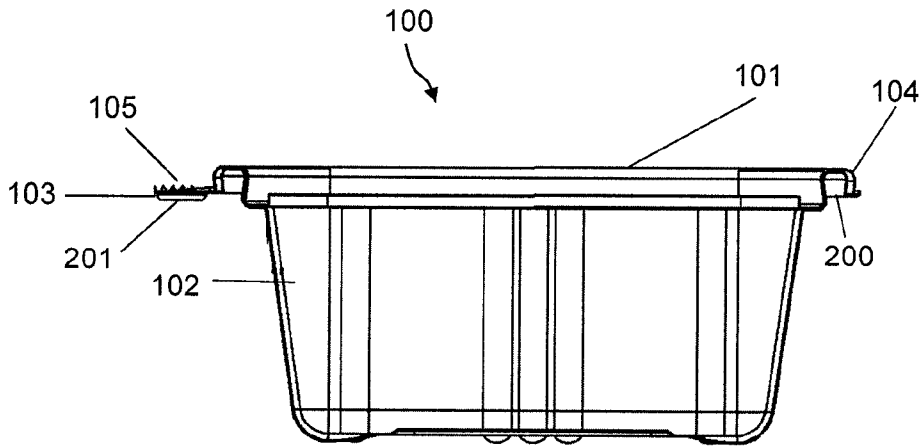

Fig. 8

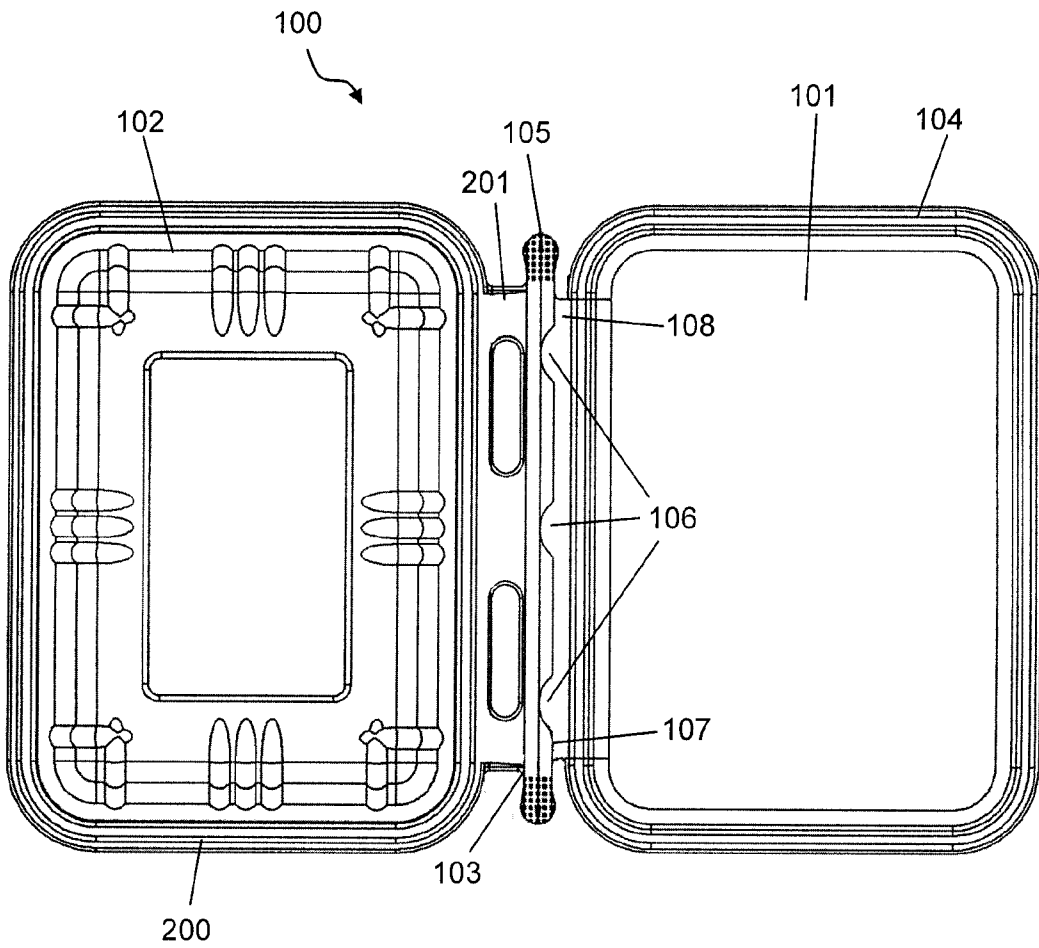

Fig. 9

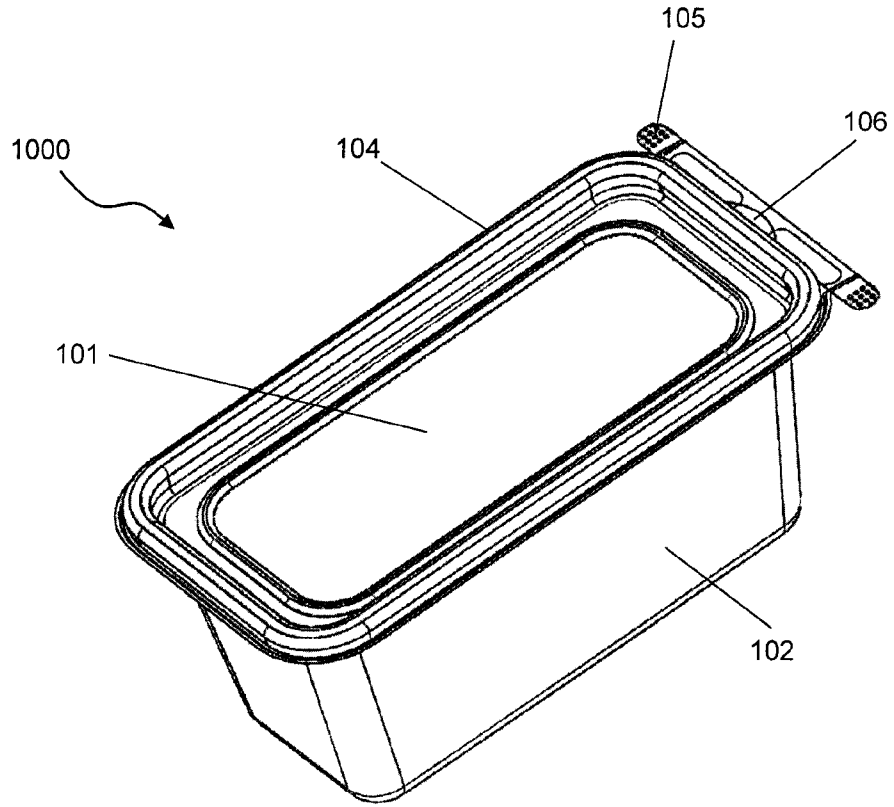

Fig. 10

