

(19) World Intellectual Property
Organization
International Bureau



(43) International Publication Date
18 March 2004 (18.03.2004)

PCT

(10) International Publication Number
WO 2004/023437 A2

- (51) International Patent Classification⁷: G09F
- (21) International Application Number: PCT/US2003/028231
- (22) International Filing Date: 8 September 2003 (08.09.2003)
- (25) Filing Language: English
- (26) Publication Language: English
- (30) Priority Data: 60/408,593 6 September 2002 (06.09.2002) US
- (71) Applicant: **VISIBLE WORLD, INC.** [US/US]; 6th Floor, 527 West 34th Street, New York, NY 10001 (US).
- (72) Inventors: **HABERMAN, Seth**; 1 West 85th Street, Apt. 11C, New York, NY 10024 (US). **NIEMELJER, Gerrit**; 23 Arcularius Terrace, Maplewood, NJ 07040 (US). **VAN DER BURGH, Abel**; 1 West 85th Street, Apt. 1F, New York, NY 10024 (US). **LUBOWSKY, Steven**; 126 Windham Road, Hillsdale, NY 07642 (US).
- (74) Agents: **LOWRY, David, D.** et al.; Brown Rudnick Berlack Israels LLP, One Financial Center, Boston, MA 02111 (US).

- (81) Designated States (*national*): AE, AG, AL, AM, AT, AU, AZ, BA, BB, BG, BR, BY, BZ, CA, CH, CN, CO, CR, CU, CZ, DE, DK, DM, DZ, EC, EE, ES, FI, GB, GD, GE, GH, GM, HR, HU, ID, IL, IN, IS, JP, KE, KG, KP, KR, KZ, LC, LK, LR, LS, LT, LU, LV, MA, MD, MG, MK, MN, MW, MX, MZ, NO, NZ, OM, PH, PL, PT, RO, RU, SC, SD, SE, SG, SK, SL, TJ, TM, TN, TR, TT, TZ, UA, UG, UZ, VC, VN, YU, ZA, ZM, ZW.
- (84) Designated States (*regional*): ARIPO patent (GH, GM, KE, LS, MW, MZ, SD, SL, SZ, TZ, UG, ZM, ZW), Eurasian patent (AM, AZ, BY, KG, KZ, MD, RU, TJ, TM), European patent (AT, BE, BG, CH, CY, CZ, DE, DK, EE, ES, FI, FR, GB, GR, HU, IE, IT, LU, MC, NL, PT, RO, SE, SI, SK, TR), OAPI patent (BF, BJ, CF, CG, CI, CM, GA, GN, GQ, GW, ML, MR, NE, SN, TD, TG).

Published:
— without international search report and to be republished upon receipt of that report

For two-letter codes and other abbreviations, refer to the "Guidance Notes on Codes and Abbreviations" appearing at the beginning of each regular issue of the PCT Gazette.

(54) Title: SYSTEM FOR AUTHORIZING AND EDITING PERSONALIZED MESSAGE CAMPAIGNS

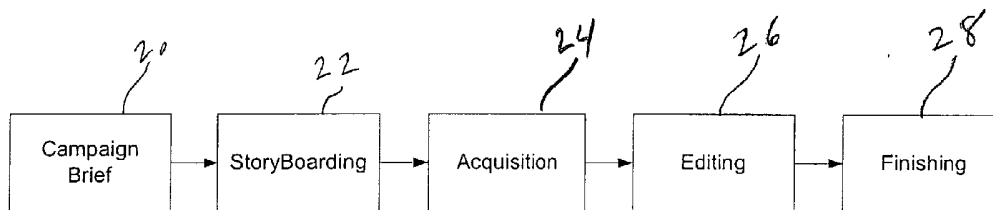

(57) Abstract: A method and system for authoring templates for personalized video message campaigns in general, and personalized TV commercial campaigns in particular. The invention allows for campaign templates to be authored and edited in such a way that commercials can be automatically generated later on in the process, when the target audience and context are known, while at the same time adhering to the existing (post) production workflows and tools. The invention maintains assembly information for messages in a format that allows easy assembly of variations of commercials at any point in the creation, editing, post-production and delivery process.

WO 2004/023437 A2

SYSTEM FOR AUTHORIZING AND EDITING
PERSONALIZED MESSAGE CAMPAIGNS

5

RELATED APPLICATION

The present application claims the benefit of U.S. Provisional Application No. 60/408,593 filed on September 6, 2002, which is incorporated herein by reference.

10

FIELD OF THE INVENTION

This invention is directed towards authoring, editing, and production systems for media and more particularly towards tools for creating personalized TV commercial campaigns.

15

BACKGROUND

The creation of media campaigns such as television commercials has become more complex as technology allows greater control and variation of creation and delivery of such campaigns. In the case of video messages, there are specific challenges with building templates for personalized message campaigns. Today's processes and products for video
20 message production are focused on the creation of single, linear video messages, and do not easily allow for the creation of sets of inter-related personalized video messages. Many things are difficult, including the ability to build templates for personalized message campaigns, in such a way that it is easy to replace certain media elements based on user information, whilst maintaining the narrative of all individual messages. Another difficulty
25 is the ability to build user profile templates, and link the user profile data to the various different media elements in a personalized message campaign template. Another difficulty is the ability to define environmental information, and link that to certain media elements in a personalized message campaign template.

As an example, the present-day process for creating (single) TV commercials is
30 illustrated in Figure 1. A typical TV commercial starts from a campaign brief 20, which is

typically created at the ad agency. The brief is a document that describes goal, target segment, and outline of the commercial. The brief can be hand-written, or created with the help of a productivity tool like a word processor or other.

5 From there, the creative team designs a linear storyboard 22, which after being approved by the advertiser, becomes the shooting board and script. The storyboard can contain sketches of the final media, or electronic representations (thumbnails). The storyboard can be hand-written, or created with the help of a productivity tool like a word processor or visualization program or other.

10 The shooting board is used by the production team during the shoot (Acquisition 24). Changes to the script and/or storyboard are changed on location after approval by the agency. The shooting board can be hand written, or created and maintained through a productivity tool like a word processor or visualization program or other. Sometimes (portable versions of) professional editing programs are used on location, so as to be able to create "rough edits" of the commercial (to ensure that the material is good). An example would be the FinalCutPro (Editing
15 Program by Apple Inc.) running on a portable Mac computer.

The resulting media elements are then finally edited 26 and locked down. Audio elements are then recorded and graphics are created. Several professional audio and video (editing) tools are typically used during this phase. Examples are: MediaComposer (Editing Program by Avid), ProTools (Audio Editing Program by DigiDesign), etc.

20 All media elements are combined into a final linear story during the finishing stage 28. Several professional audio and video (finishing) products are typically used during this phase. An example is Symphony (Finishing Program, Avid). The last two phases (Editing 26 and Finishing) 28 are together referred to as Post-Production. The resulting linear commercial is then either stored on a file server or mastered to videotape.

25 Most present-day TV commercials are created this way, yet there are numerous possible variations on this basic workflow, such as:

- Multiple storyboards (or even complete commercials) are created in parallel, the advertiser will then finally select one of them for final airing.
- Iteration in the process, in other words certain steps are repeated one or more times, until

the result is approved by the advertiser.

- The storyboarding process actually includes the production of a basic low-cost version of the commercial (or at least an animation) so as to make the approval process easier.

Whatever variant on this process is followed, and whatever electronic tools are used to support this, the process is fundamentally designed to produce linear stories where the narrative starts with a particular shot, then moves to the next single shot, and so on until the story is told. Further, although current video editing and finishing applications allow for multiple video, audio and graphics tracks to be active during the creation process, at the time of finishing, all of these tracks are resolved down to a final linear set, as shown in Figure 2. There is usually one video track 30, with graphics superimposed, and two or four audio tracks 32.

When this process is used to create different versions of a commercial, the finishing process actually results in a set of separate linear TV commercials that are not related to each other anymore (although 80% of the content of the commercial may be identical). If it becomes necessary to make changes in the "common" part of the TV commercials, it is necessary to go back to the production process and re-do all different variants of the commercial. More specifically, the process does not allow for elements of the commercial to be automatically changed/customized later on in the process (the commercial is already finished, and cannot be changed anymore without going back to the production and finishing process). This makes it impossible to automatically generate personalized versions of the commercial that are specific for a given audience or context at (or close to) the time of play out.

Simply put, one of the limitations of the present day process is that after post-production, all relations between media (different versions) and data (demographics) are lost. All that is left is a (set of) linear TV commercial(s). This makes it impossible to automatically change the commercial and make it more relevant to a target audience later on in the process.

SUMMARY

The present invention includes a method for authoring personalized video messages more easily. An illustrative embodiment of the present invention is described in terms of a set of tools.

The present invention includes a method for creating a message campaign, the message
5 campaign allowing the creation of a plurality of different messages to targeted audiences. A specific targeted audience receives a selected one of the plurality of different messages based upon criteria of the specific targeted audience. The method includes providing a plurality of media segments, the media segments for assembly into the plurality of different messages to targeted audiences, wherein at least one of the media segments is interchangeable with another
10 one of the media segments. The media segments may be created, preexisting or created at a later time. The method also includes providing assembly information regarding how the plurality of media segments may be assembled to create the different messages. The assembly information is then associated with the plurality of media segments. This assembly information and media segments may then be packaged up to be broadcast or dispersed.

15 Further, a message for a specific targeted audience may be assembled at a later time, the message being assembled based upon the assembly information, the plurality of media segments, and on information regarding the target audience. An example is selecting media segments based on a target audience's age or preferences, and using that media segment along with other related or unrelated media segments to assemble the message. Further, one or more media segments
20 used to assemble the messages may be created at the later time. An example is titling for a message or commercial may be created and assembled with the message right before it is shown to a target audience.

The assembly information may include rules for use at the later time, the rules for use in
25 determining which of the plurality of the media segments to use in assembling a message for the specific targeted audience, based on the information regarding the target audience. The rules can include "default conditions" for determining which of the plurality of the media segments to use when no appropriate information regarding the target audience is available. A subset of the plurality of media segments can form a default generic message.

Media segments can include audio, video, voice overs, and background music. Each type of

segment can be assembled with other segments based on information or conditions imposed by the assembly information. The assembly information can include data representing time segments; the media segments, and conditions. This assembly information forms a network which maintains a matrix-like overview of the media segments, their timing, and how they may be combined with other media segments in order to assemble the messages. In one illustrative embodiment, the message for a specific targeted audience is assembled in a set top box for a television receiver contemporaneously with displaying the message to the specific targeted audience.

The specification includes illustrative embodiments focusing on a television commercial as a specific form of personalized video message, yet it is easy to see that the approach is equally valid for personalized video messages in general (e.g. personalized news casts) and even personalized messages in general (e.g. personalized audio message, personalized multi-media presentation).

An illustrative embodiment defines the concept of a matrix to represent sets of video messages in general, and a personalized commercial campaign template in particular. The matrix defines TV messages in terms of defaults and options for video, audio, narration, titling overlay, and other media elements. The matrix associates segmentation data with the various media options. Once the matrix is created, produced, and finished, it can be played out at different delivery networks, to different target audiences, in different contexts, in which case it will each time generate a specific TV commercial that is customized to audience and context. A possible implementation of a method for authoring personalized messages using the matrix concept specifically focuses on a data model (network) that represents the matrix-based message template. The data model typically is object oriented, and can be stored in relational database or other to form a data repository that is shared among tools. The tools will use the data in the repository, and interface with the workflows and tools that are currently being used during production of TV messages.

One advantage of the illustrative embodiment over existing (post) production tools and products, is that it allows for campaign templates to be authored in such a way that the commercial can be automatically generated later on in the process, when the target audience and

context are known, while at the same time adhering to the existing (post) production workflows and tools.

Another advantage is that it is possible to produce and finish sets of (related) TV commercials more efficiently. For instance, if a set of related TV commercials (in a matrix-based system) share a piece of media (e.g. the opening scene), and that piece of media needs to be re-worked (e.g. re-edited), then the tools and system as described in this document will allow for this to be done by one single edit session, after which the update will effectively "ripple" its way through the matrix of related commercials (whereas in the current process, one would have to individually re-work all individual messages). This brings an efficiency advantage to (post) production of related TV commercials.

Yet another advantage over the current process for producing TV commercials lies in the moment of media assembly. In the current process, TV commercials are singular after production, in other words: the final choice of media is made during the production and finishing process. In fact the post-production can only be finalized if all media choices are made. The concept of a narration matrix according to one embodiment of the present invention allows sets of related commercials to be post-produced, effectively delaying the moment of final media choice and assembly until after the post-production process (to a point where the audience and context are better known).

BRIEF DESCRIPTION OF THE DRAWINGS

The foregoing and other features and advantages of the present invention will be more fully understood from the following detailed description of illustrative embodiments, taken in conjunction with the accompanying drawings in which:

- Fig 1. shows the process of workflow for commercials in the prior art;
- Fig. 2 displays the linear narrative result of the workflow process of Fig. 1;
- Fig. 3 shows a video matrix according to the present invention;
- Fig. 4 shows an example video matrix with multiple shots per option;
- Fig. 5 shows an example nested video-matrix;

Fig. 6 shows an example double narrative nested matrix;

Fig. 7 shows an example matrix with restrictions;

Fig. 8 shows an example of fully disjunct commercials in a matrix;

Fig. 9 shows an overall matrix according to the present invention;

5 Fig. 10 shows a titling matrix according to the present invention;

Fig. 11 show an example titling matrix with parameters;

Fig. 12 provides an overview of a suite of authoring tools according to an illustrative embodiment of the present invention;

10 Fig. 13 provides a mapping of authoring tools on workflow as previously described in Fig. 1;

Fig. 14 shows samples of simple networks according to the present invention;

Fig. 15 shows a screen shot of a storyboard tool according to an illustrative embodiment;

and

Fig. 16 shows a postman tool screen shot according to an illustrative embodiment.

15

DETAILED DESCRIPTION

U.S. Patent application number 09/545,524 entitled TEMPLATE CREATION AND EDITING FOR A MESSAGE CAMPAIGN and assigned to Visible World Inc., describes a novel system for creating personalized messages for audiences and is incorporated herein by
20 reference.

The present invention introduces a new, efficient way of authoring personalized TV commercial campaign templates, based on the concept of Matrix-Based Narrative. Matrix-Based Narrative provides the ability for commercial campaign templates to be authored in two dimensions (time and choice), and the resulting finished commercial campaign template will still
25 include these two dimensions (as opposed to the current approach, where a finished commercial only has the time dimension, since there is no element of choice anymore). More specifically a Matrix-Based Narrative contains a linear (default) commercial, but for one or more elements (called "slots") of this commercial it contains multiple play-out candidates (called "options").

A simple example of such a matrix according to the present invention is shown in Figure

3. For the sake of simplicity, this example only considers the video-part of the commercial (ignoring audio- and other elements for now). The example illustrates a simple commercial, consisting of five shots, where shot 2, 4, and 5 are actually slots with multiple options. It is easy to see that the video-matrix defines a default commercial 32 (composed of Shot 1, Shot 2A, Shot 3, Shot 4A, Shot 5A) as well as twenty-three alternative commercials (generated by sequencing the various permutations of options for each slot). Total number of commercials contained within the video-matrix is twenty-four ($=1 \times 4 \times 1 \times 2 \times 3$).

In order to understand how this video-matrix can be applied to define any set of commercials, it is helpful to look at some more examples. First, consider an example shown in Figure 4, that is similar to the previous example, yet allows for a slot to contain an arbitrary number of shots, as long as the length of the various options for a given slot is identical. In this example there is a default commercial 34 (Shot 1-1, Shot 1-2, Shot 2A, Shot 3, Shot 4A, Shot 5A1, Shot 5A2) as well as 23 alternative commercials.

Another example as shown in Figure 5 is where there is nesting of slots (in other words: a choice within another choice). In this example, the default commercial 34 consists of the sequence (Shot 1, Shot 2A, Shot 3). The alternative commercial has Shot 2A replaced, resulting in the sequence (Shot 1, Shot 2B/1, Shot 2B/2a, Shot 2B/3, Shot 3). However, since the second shot in the 2B-sequence is again a slot with more options, there are two more valid commercials in this video-matrix, namely (Shot 1, Shot 2B/1, Shot 2B/2b, Shot 2B/3, Shot 3) and (Shot 1, Shot 2B/1, Shot 2B/2c, Shot 2B/3, Shot 3). So the total number of commercials in this video-matrix is four ($=1 \times (1 + (1 \times 3 \times 1)) \times 1$).

A slightly more complex example of nested slots is illustrated in Figure 6. In this example the default commercial 34 is (Shot 1, Shot 2A/1, Shot 2A/2a, Shot 2A/3, Shot 3). There are two slots within that message: Shots 2A together represent a slot, yet within that also Shot 2A/2a represents a (nested) slot. The same is true for shots 2B and shot 2B/2a. Therefore, in addition to the default commercial 34, the following sequences represent valid commercials in the video-matrix: (Shot 1, Shot 2A/1, Shot 2A/2b, Shot 2A/3, Shot 3), (Shot 1, Shot 2B/1, Shot 2B/2a, Shot 2B/3, Shot 3), (Shot 1, Shot 2B/1, Shot 2B/2b, Shot 2B/3, Shot 3), (Shot 1, Shot 2B/1, Shot 2B/2c, Shot 2B/3, Shot 3). Total number of commercials in this video-matrix is five

(=1 x ((1 x 2 x 1)+(1 x 3 x 1)) x 1).

A video-matrix may contain many sequences (permutations of shots and options), some of which may be invalid. In the present invention it is possible in a video-matrix, to specify which permutations are invalid. This effectively reduces the number of commercials within a video-matrix, as shown in the example presented in Figure 7. This video-matrix would normally contain six (1 x 2 x 3 x 1) different commercials. But for this example, assume that for some reason the author of the video-matrix does not want the combination of Shot 2A with Shot 3B to occur in any commercial. The author would then put a limitation in the video-matrix that renders invalid any commercial that contains this combination of shots. The result would be that the video-matrix now "only" contains five ($(1 \times 3 \times 2 \times 1) - 1$) valid commercials, namely (Shot 1, Shot 2A, Shot 3A, Shot 4), (Shot 1, Shot 2B, Shot 3A, Shot 4), (Shot 1, Shot 2B, Shot 3B, Shot 4), (Shot 1, Shot 2C, Shot 3A, Shot 4), (Shot 1, Shot 2C, Shot 3B, Shot 4).

By combining all these techniques and examples, and applying them to real sets of commercials, it is clear that any set of commercials that have common elements can be expressed as a video-matrix. Moreover, even in the "worst" case of a set of commercials that have no common elements at all, it is possible to combine the commercials in a video-matrix. One would simply create a "slot" that covers the full length of the commercial, and the various commercials would represent full and complete options within that slot, as is illustrated in Figure 8. This video-matrix contains exactly 2 valid commercials, namely the default (Shot 1, Shot 2, Shot 3, Shot 4, Shot 5) and the alternative one (Shot 6, Shot 7, Shot 8, Shot 9).

The disclosure so far has only described the video part of TV commercials. The present invention is not limited to video, but also extends to audio and other multi-media elements. For this purpose, additional dedicated matrices for titling, voiceovers, and music are introduced. Conceptually these matrices all describe different "planes" or "views" of the template, where the resulting overall commercials are built by combining all these "planes" into discrete commercials. The four matrices can all have slots and options independent of each other. An example of an overall-matrix 36 is shown in Figure 9. The titling-matrix 38 contains the various graphics and/or titles that are going to be part of the commercial. The voiceover-matrix 40 contains the voiceover clips, and the music-matrix 42 contains the background music clips. The

four matrices are combined into an overall-matrix 36 that represents the final personalized commercial campaign template including video, audio, and graphics.

This overall matrix describes a set of TV commercials with twenty-four (= 1 x 4 x 1 x 2 x 3) video messages, two titling messages, four (= 1 x 4 x 1) voiceover messages, and two music messages. Theoretically the total number of different TV commercials contained within the overall-matrix is therefore three hundred and eighty-four (= 24 x 2 x 4 x 2). However in reality there will typically be restrictions built into the matrix, for instance certain voiceover options can only be combined with certain video options, so that the real number of valid TV commercials in the matrix would typically be less than three hundred and eighty-four.

Note that more matrices may be added for specific multi-media elements if required. For example there could be a matrix for interactive application data that is part of a commercial, further there could be multiple video matrices for devices that combine multiple video sources, etc.

An example of a titling matrix is shown in Figure 10. As discussed in the previous section, titles and graphics can be expressed as media elements in a matrix, so that there can be variation in the titling and graphics of a matrix of TV commercials. This simple matrix represents a situation with no titling-overlay 44 in the beginning of the commercial, followed by a default title overlay "Title 1", with an alternative title overlay "Title 2". The end of the commercial, again carries no titling-overlay 44.

In addition to this, the titling matrix 38 enables one to parameterize the title overlay by including references to values that will be computed later on (from database tables, or other sources of information). Consider the example in Figure 11. This matrix represents a situation with no titling overlay 44 in the beginning of the commercial, followed by a default title overlay 46 "Visit your store today at %address%", where %address% is referring to a store address that is computed later on (from a database or otherwise). The alternative title overlay 48 is "Order Today! Call %phone_nr%", where %phone_nr% refers to a phone number that is computed later on. If the computation of store addresses, resp. phone numbers, results in NR_ADDRESSES different store addresses, and NR_PHONE_NUMBERS different phone numbers, then it is clear that this titling matrix represents NR_ADDRESSES + NR_PHONE_NUMBERS different titling

overlay sequences for the associated commercials.

The concept of a matrix, as defined in the previous sections, basically introduces a representation for personalized TV commercial campaign templates. For example, a matrix can represent a campaign, where the actual TV commercial that is shown to an individual (or group) is customized to, and specific for that individual (or group).

In order to facilitate this, the matrix concept is extended with the concept of a target. A target is an individual, or a group of individuals, that may view one of the TV messages in the matrix. The set of all targets represents the set of all potential viewers of TV commercials from the matrix. A target is defined in terms of segmentation parameters. Segmentation parameters may be demographic parameters (e.g. income level), environmental parameters (e.g. current temperature outside), contextual parameters (e.g. which TV channel is currently being watched), or any other parameters. Each segmentation parameter may have a set of values. The matrix allows segmentation-parameter values to be attached to slot-options. These associations can be simple (e.g. "slot option B1" is associated with "income=high") or may be combined in more complex expressions (e.g. "slot option B2" is associated with "income=low AND current_temperature>50"). Since any target can be represented as a set of values for the segmentation-parameters, this mechanism can be used to associate one or more targets with each TV commercial in the matrix.

It is important to note that this mechanism may work with any set of segmentation parameters (with finite, or even infinite values), and with any expression syntax for combining values (Boolean logic, fuzzy logic, rule-based systems, etc.).

Personalized TV commercials may be delivered over various distribution networks. Examples of distribution networks include: analog cable networks, digital cable networks with set top boxes with or without hard disks, digital satellite networks with set top boxes, internet streaming, Video-On-Demand-systems, distribution on hard media such as CD or DVD discs, etc.

Certain networks may impose certain restrictions on personalized TV messages. These restrictions can be fundamental (e.g. a certain network does not support a certain type of audio formats) or practical (e.g. a certain network operator wants to allocate only finite resources to a

personalized TV campaign in terms of storage and/or bandwidth). This can easily be represented in the matrix as a set of delivery-related restrictions. These restrictions can be bandwidth related (e.g. the total number of different options for slots at a specific point in time not to exceed X), storage related (e.g. the total size of all media fragments in a matrix not to exceed Y), or other.

5 It is also important to point out that, since a matrix may be designed for different delivery networks, with different characteristics, a matrix may have different sets of restrictions associated with it, one per delivery network.

Tools used in the present day for media creation and editing will benefit from the present invention. Presently, linear commercials are authored and finished based on the workflow as
10 depicted in Figure 1. This workflow is supported by a variety of tools, such as Non-Linear-Editors (NLEs), Audio Editors, etc. Matrix-based templates according to the present invention provide enhancements to this workflow and the tools that support it. The present day tools, by themselves, are not properly equipped to build and finish matrix-based templates. Descriptions of
15 tools and illustrative embodiments that support matrix-based template building will now be disclosed. The tools are designed in such a way that they augment the present day production processes and tools (instead of replacing them). This makes their initial acceptance much easier. Alternative implementation strategies are discussed further below.

An illustrative embodiment of a high-level design of a tool set is illustrated in Figure 12. The basic premise is to introduce a suite of tools that assist in the workflow in order to facilitate
20 the authoring of matrix-based templates. The tools interface with the processes and products that are currently used in production and post-production. Each tool is specifically designed to assist in one (or two) phases of the workflow (as illustrated in Figure 13). They share information through a common repository 50.

The fundamental goal of the tools is to build and maintain a data model that defines the
25 relation between media, data, and different variants of the TV commercial (which is something the currently existing tools cannot do). This is done in an illustrative embodiment by maintaining a data model (called network or template) that links all media and all data together. This network is defined in early stages in the process, and is refined and finished in the final stages. A network is shared between all tools. A network consists of three basic building blocks (called elements or

objects) that can be combined to represent any matrix-template:

- Media Elements represent one or more pieces of media. This can be a video shot, a series of video shots, audio, titles, pictures, etc. A media element may also contains meta-data on the media elements it represents (for instance what actors appear in it, descriptive text, copyright information, etc.).
- Conditions represent expressions that allow for certain parts of the network to be conditional upon audience data (such as demographics). The expressions can be logical expressions, fuzzy logic, or any other conditional expression language. The data can be demographics data, real-time data, or any other type of data that is either stored in databases, or is made available in another way. Conditions also have the concept of priority. So two conditions may both be true, but they may have different priority.
- Time Nodes represent specific times in the network. Time Nodes can have relative time or absolute time. They typically represent the timing of a choice in the network.

A number of examples of networks are shown in Figure 14 (rounded squares marked M represent media elements, circles marked T represent time nodes, and diamonds marked C represent conditions).

The first example (A) starts with a simple network that starts with a time node (T1), followed by a media element (M1), and ends with time node (T2).

The second example (B) shows a similar network, but now the media element is associated with condition (C1). If C1 is true, the effect of example B is identical to example A. If C1 is false the network is empty (just has a begin time and end time). In the general case media elements (or sequences of media elements) have conditional associated with them, but in case that condition is always true, it may be left out. In other words, example A could be represented as example B with C1=always true).

The third example shows a start time node (T1), followed by media element (M1), followed by time node (T2), followed by media element (M2), ending with time node (T3). This represents a simple timed sequence of two media elements.

The final example (D) starts with time node (T1), followed by media element (M1), followed by time node (T2). After this, there are two possible media elements, M2 and M3, both followed

by end time node (T3). Media element M2 is associated with condition (C1), and media element (M3) is associated with condition (C2). This network represents a timed conditional sequence of media elements as follows:

5

Table 1

Evaluation of Conditions	Resulting Sequence
C1 = false AND C2=false	M1
C1 = true AND C2 = false	M1, followed by M2
C1 = false AND C2 = true	M1, followed by M3
C1 = true AND C2 = true AND priority(C1) > priority (C2)	M1, followed by M2
C1 = true AND C2 = true AND priority(C2) > priority(C1)	M1, followed by M3

These examples illustrate the basic concepts of a network, and suggest how a network may be used to express more complex matrix-based templates.

A more formal definition of a network is as follows.

10 Networks are built from the following 3 basic elements (which can be thought of as objects or object classes):

- Media Elements represent media sequence(s). They basically contain references to the media in some form, as well as meta data on that media. There are different types of media elements, one for video media, titling media, audio media, narration media (more
15 can be added if needed).
- Conditions represent expressions that may refer to data in databases, or any other data. These expressions will render true or false, depending on the values of the underlying data, as well as a priority. The priority is used to select between multiple conditions that render true at the same point. The expressions may be in any expression language.
- 20 • Time Nodes represent discrete points in the timeline of a commercial. There is a start time node, an end time node, and there can be any number of time nodes in between.

Elements in a network may be connected as follows:

- A network always starts with at least one start time node.

- A time node can be followed by another time node. This represents a situation where a certain time interval in the commercial is (still) empty.
- A time node can be followed by a media element. This represents a situation where the media elements start at a specific time in the commercial.
- 5 • A time node can be followed one or more conditions. This represents a situation where there is an element of choice at a certain specific time in the commercial. When executed, the condition that renders true and has the highest priority, prevails.
- A time node can be followed by a media element as well as one or more conditions. This represents a situation where there is an element of choice between the default (media
10 element) and other options (conditions). When executed, the condition that renders true and has the highest priority prevails. In case all conditions render false, the default prevails.
- A condition is always followed by a media element. This represents the fact that the conditional expression is associated with that specific media sequence.
- 15 • A media element is always followed by one time node. This represents the fact that a media sequence always ends a specific time.
- Multiple media elements may be followed by the same time node. This represents an end of a slot.
- A network always ends with at least one end time node.
- 20 A network can be stored in different ways. Since a network basically consists of a collection of elements and relations between these elements, it can be stored in a relational database, in a object-oriented database, in XML files, in proprietary formats, etc. The main thing is that there is a place to store networks, and to share them between the various tools that access and manipulate them. In the remainder of this chapter we will refer to this place as the Shared Repository.
- 25 In the illustrative embodiment, a network is a representation of a personalized commercial campaign template. It is built, manipulated, and finalized through a set of tools. Each tool has specific tasks in building or refining the network. Each tool will also enforce specific constraints and constructs, so that at the end of the process, the resulting network will represent a valid campaign template.

The StoryBoard Tool 52 essentially builds the network (create media elements, time nodes, and conditions, and connect them in a meaningful way). The resulting network will be complete, although the media elements may not yet have media associated with them (or temporary media), the conditions are in place (although the final underlying database functions may not be in place yet), and the time nodes are in place (although they may only indicate rough timing).

The User Interface of the Tool represents the network structure in an intuitive and user-friendly way. An implementation of the User Interface may combine three different windows:

The main network window provides a representation of the network. The network is divided in four different sub-networks (video, audio, titling, narration). The various media elements can be associated with (and shown as) scanned images, stills, or any other representations. The network can be shown completely, or sub-networks may be hidden (e.g. only look at video and narration, hide titling and audio). There is an option to select and browse single paths through the network. Time nodes are not shown explicitly, but are implicitly derived from timing of various media elements. Although this time is not going to be final (final timing is typically determined during post-production), they may be used as rough time indicators. The matrix can be shown in non-timed mode (e.g. each shot has same length) or in absolute time-mode (length of shots shown proportionally).

The data/selection window is essentially a representation of expressions and data within expressions. The window contains a representation of the various segmentation parameters that are available to the campaign designer (for instance "income=high" or "age=young"). These parameters represent condition objects. They can also be combined (for instance "income=high AND age=young") in which case a new condition object is created to represent the combined expression). The various parameters and expressions can be dragged and dropped to media elements in the main network window. This has the effect of creation a new condition and inserting it in the network before the media element.

The media window can be used to browse available media elements. These elements can be scanned images, still images, etc. They basically represent the media elements that are available for building a network. Any element can be dragged and dropped onto the main network window. This will have the effect of creating a new media element, inserting it at a certain place

in the network (also creating one or two time nodes when needed).

A screen shot of a storyboard tool according to an illustrative embodiment is shown in Figure 15. A main network window is shown on the right side, and a set of stacked media windows is on the left side. A data/selection window is not shown in this example. The StoryBoard may be used to create a brand new network, yet can also be used to refine or modify an existing network. In reality it will probably be used in several sessions to go from initial concept to final network. The StoryBoard Tool 52 will ensure that, at all times ensure that the network is structurally correct (e.g. following the formal network specification rules as previously described).

In addition to this, the StoryBoard Tool 52 can also check against delivery constraints.

Delivery constraints are specific limitations related to bandwidth or storage or formats that are imposed by specific delivery networks. Examples are: certain digital cable network may not support certain audio types, or a certain satellite network may have bandwidth limitations that restricts the number of simultaneous slot options, etc. The StoryBoard Tool 52 will check these constraints by inspecting the network data structure, and issuing appropriate warnings where necessary.

In an illustrative embodiment, a StoryBoard Tool 52 may also have the following features:

- Printing features, including the ability to print high-quality, customized reports of the campaign template.
- Animation features, including the ability to select a target (or set of segmentation parameter values) and play out an animated version of the associated commercial.
- The ability to "pre-package" certain parts of the network (in terms of structure, or pre-packaged segmentation parameters, or any combination thereof), and be able to save these as templates (which can be used as starting points for building several other networks).
- The ability to (automatically or manually) check the matrix against delivery constraints (including specific warnings about where delivery constraints are violated and how that could be fixed).
- The ability to import segmentation data from other systems and tools in general, and from data analysis and data segmentation tools specifically.

An illustrative embodiment of a Location Tool 54 assists producer and production crew in acquiring material for a matrix-based commercial. The tool needs a valid network structure as input (typically built by the StoryBoard Tool 52). The tool will analyze the network, and extract all media elements from it, and present an "electronic checklist" of the media that needs to be
5 filmed, recorded, computer generated, or otherwise created. This checklist is interactive, so that the production crew can "electronically check off" the media that are acquired. As far as the network structure, the Location Tool 54 may only (optionally) update the existing media elements to refer to the newly acquired raw media. Typically the tool does NOT change the network in any other way.

10 An illustrative embodiment of a Titling Tool 58 assists creative staff and editors to design the titles that are used in the campaign. While the Storyboard Tool 52 and Postman Tool 56 define when titles appear in the messages, the Titling Tool 58 focuses on the actual screen layout, effects, precise timing, etc. It allows the appearance of the title to be designed, while the content of the title can later on be customized/changed according to the play-out rules and data.

15 The Titling Tool 58 typically needs a valid network structure as input (typically built by the StoryBoard Tool 52). The tool will only access the titling sub-network. It analyzes the titling sub-network, and allow creative designers (on a per titling media element basis) to design the exact screen-layout of the element, precise timing, add effects, etc. As a result, the titling sub-network will be updated as follows:

- 20
- Time nodes within the titling sub-network may be updated (to reflect changes in precise timing of the individual titles).
 - The titling media elements will be updated to refer to the newly designed titling formats, as well as additional meta data on effects etc.

Typically the Titling Tool 58 does not change the network in any other way.

25 An illustrative embodiment of a PostMan Tool 56 is used to do the final updates of the network structure and make it ready for further automatic processing and delivery. The Postman Tool 56 plays a central role during post-production (editing and finishing). It interfaces with all other products that are used in production and post-production. The user interface of the tool represents the network structure in an intuitive and user-friendly way. An implementation of the

User Interface may combine three different windows:

- The main network window as a representation of the network. It looks very similar to the main network window in the StoryBoard Tool. The network is divided in 4 different sub-networks (video, audio, titling, narration). The various media elements can be associated with (and shown as) scanned images, stills, or any other representations. The network can be shown completely, or sub-networks may be hidden (e.g. only look at video and narration, hide titling and audio). There is an option to select and browse single paths through the network. Time nodes are not shown explicitly, but are implicitly derived from timing of various media elements. The matrix can be shown in relative time-mode (e.g. each shot has same length) or in absolute time-mode (length of shots shown proportionally). All media elements in the main network window have a status label. The status label indicates whether or not the specific media sequence is finalized and valid. So for instance if the media sequence for a certain media element is still un-edited it will be marked with a red label, if the media sequence is edited and finished and final it will be marked with a green label. See also the PostMan Tool algorithm description below.
- The selection window is essentially a representation of the various conditions and "paths" through the network. It is used to select certain parts of the network for production and post-production. The list will typically contain a "default" path, and all alternative paths. There is color-coding in the list to indicate paths that are finished, are still to be done, or are in conflict.
- The media window can be used to browse available media elements. These elements can be scanned images, still images, etc. that can be associated with the media elements in the network. These images are for display only, and will not affect the final media.

An example screenshot of the PostMan Tool is shown in Figure 16. It shows the main network window at the top, the selection window at the bottom right, and a media window at the bottom left. The PostMan Tool works from an existing, valid network structure, which it manipulates as follows:

- Time nodes within the titling sub-network may be updated (to reflect changes in precise timing of media elements).

- The media elements will be updated to refer to the final media, as well as additional data on effects etc.

Typically the tool does not change the network in any other way. The tools will produce the final network structure that is ready for further processing and delivery.

5 In an illustrative embodiment, the basic algorithm of the PostMan Tool is:

1. Mark all media elements in the network as invalid
2. Select next (partly) invalid media sequence from the network
3. Interact with post-production tools to produce a finished, post-produced version of that media sequence.
- 10 4. Check the finished media sequence for consistency with the network.
5. If inconsistent: trigger user, and present with options for repairing the inconsistency
6. If consistent: update the network structure to reflect the newly finished media sequence
7. If there is at least one invalid media element in the network: go to step 2.

15 Explanation:

1. The initial step is to render all media elements as invalid (meaning: not finalized). The status of a media element is kept in the network structure. The PostMan Tool will mark all media elements (in its main network window) with a status label reflecting its status, which can be either valid (green label) or invalid (red label).
- 20 2. During this step a next media sequence will be selected from the network. A media sequence is a complete set of media elements, and can either be video, audio, narration, titling, or any combination thereof. A sequence can consist of any combination of valid and invalid elements. The sequence can be hand selected by the operator of the tool, yet the tool will suggest the most optimal next sequence. The initial suggestion will be the default commercial. After that
25 the sequence with the biggest number of invalid media elements will be suggested.
3. During this step a media sequence will be transferred to the appropriate post-production tool, where it will be produced and/or finished. An example is a sequence of video, audio, narration, and titles that will be transferred into a Non Linear Editor (NLE) for editing. The transfer can be through any interface that allows for the Non Linear Editor to be "loaded" with a

media sequence to be edited.. It is important that all elements in the media sequence are labeled with unique identifiers (by the PostMan Tool), and that these identifiers are kept during the editing process, and return with the media sequence when returning from the NLE to the PostMan Tool. One possible implementation of the communication interface between PostMan

5 Tool and post-production tools is AAF (Advanced Authoring Format), which provides a standard protocol for transferring media structures.

4. Once the finished, post-produced media sequence is returned from the post-production tool to the PostMan Tool, the latter will check the consistency between the sequence and the network structure (it originated from). This check is by done by taking the unique identifiers of

10 the media elements, and using them to "find back" the original media sequence in the network, and then comparing the two for consistency.

5. The consistency check may reveal one or more of the following problems:

a. Media elements may have wrong identifiers, or they are out of order. This error will be presented to the user, and unless the user re-arranges and/or modifies the identifiers, this is a non-

15 correctable problem.

b. Media Elements have no identifier. This is a correctable problem, since the PostMan Tool will simply "add" these elements to the closed possible element that does have a known identifier.

c. The timing of the new sequence is different from the network, and is incompatible with

20 timing of already validated media elements (e.g. different options for the same slot now have different lengths). This will be flagged to the user, who will have to choose which timing is valid.

6. In case of a non-conflicting situation, the network structure will be updated to include the newly finished media sequence. This may include: changing time nodes, and updating media elements to refer to the final media, and adding metadata.

7. Repeat these steps until all media elements in the network are valid at the same point in

25 time. In this case the network is ready for further processing and delivery.

The tools as described in the previous paragraphs are just one possible implementation of the present invention for a system for authoring (matrix-based) personalized messages. Alternative implementations are possible. There are at least two different approaches to

alternative implementations:

1. Leaving the current workflow and tools intact, yet augment them with a separate layer of authoring tools (just like the implementation as previously described), yet with a different implementation of the layer of authoring tools. Different tools implementations include: combine
5 multiple tools in one tool, or break-up the tools functionality over more (or different) tools. It could also mean that certain tool functions are more intimately "added" to the existing post-production products (for instance through plug-ins in Non Linear Editing systems).
2. Creating a completely new implementation, where current post-production workflows and tools are replaced with new workflows and tools that combine the original functions with the
10 functions of matrix-based messages. An example of this is to create a new Non Linear Editing system that features editing matrix-based messages. These two approaches can also be mixed.

Although the invention has been shown and described with respect to illustrative embodiments thereof, various other changes, omissions and additions in the form and detail thereof may be made therein without departing from the spirit and scope of the invention.

15

What is claimed is:

CLAIMS

1. A method for creating a message campaign, said message campaign allowing the creation
5 of a plurality of different messages to targeted audiences, wherein a specific targeted audience receives a selected one of said plurality of different messages based upon criteria of said specific targeted audience, said method comprising:
- providing a plurality of media segments, said media segments for assembly into said
plurality of different messages to targeted audiences, wherein at least one of said media segments
10 is interchangeable with another one of said media segments;
- providing assembly information regarding how said plurality of media segments may be
assembled to create said plurality of different messages to targeted audiences; and
- associating said assembly information with said plurality of media segments.
- 15 2. The method of claim 1 wherein a message for a specific targeted audience is assembled at a later time, said message being assembled based upon said assembly information, said plurality of media segments, and on information regarding said target audience.
3. The method of claim 2 wherein at least one media segment used to assemble one of said
20 specific messages is created at said later time.

4. The method of claim 2, wherein said assembly information includes rules for use at said later time, said rules for use in determining which of said plurality of said media segments to use in assembling a message for said specific targeted audience, based on said information regarding said target audience.

5

5. The method of claim 4 wherein said rules include default conditions for determining which of said plurality of said media segments to use when no appropriate information regarding said target audience is available.

10 6. The method of claim 1 wherein said media segments include audio, video, voice overs, and background music.

7. The method of claim 1 wherein a subset of said plurality of media segments form a default generic message.

15

8. The method of claim 1 wherein said assembly information includes data representing time segments; said media segments, and conditions.

9. The method of claim 2 wherein said message for a specific targeted audience is
20 assembled in a set top box for a television receiver contemporaneously with displaying said message to said specific targeted audience.

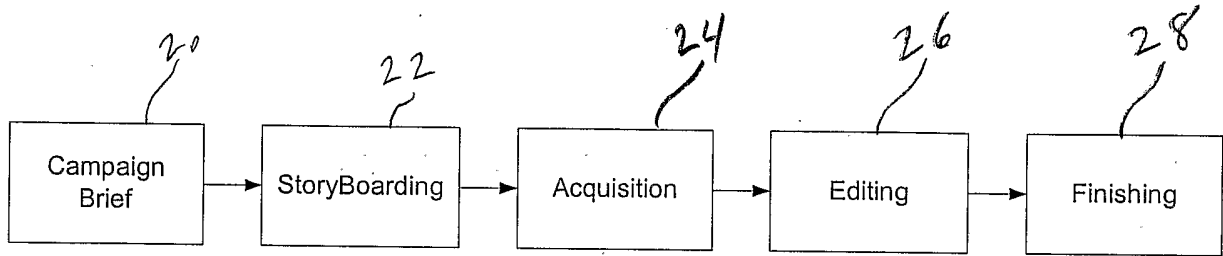

Fig. 1 (prior art)

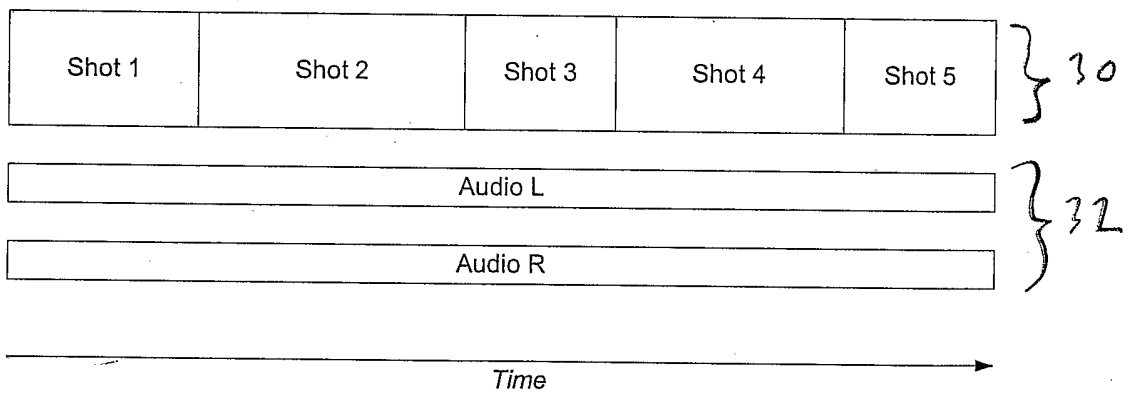

Fig. 2 (prior art)

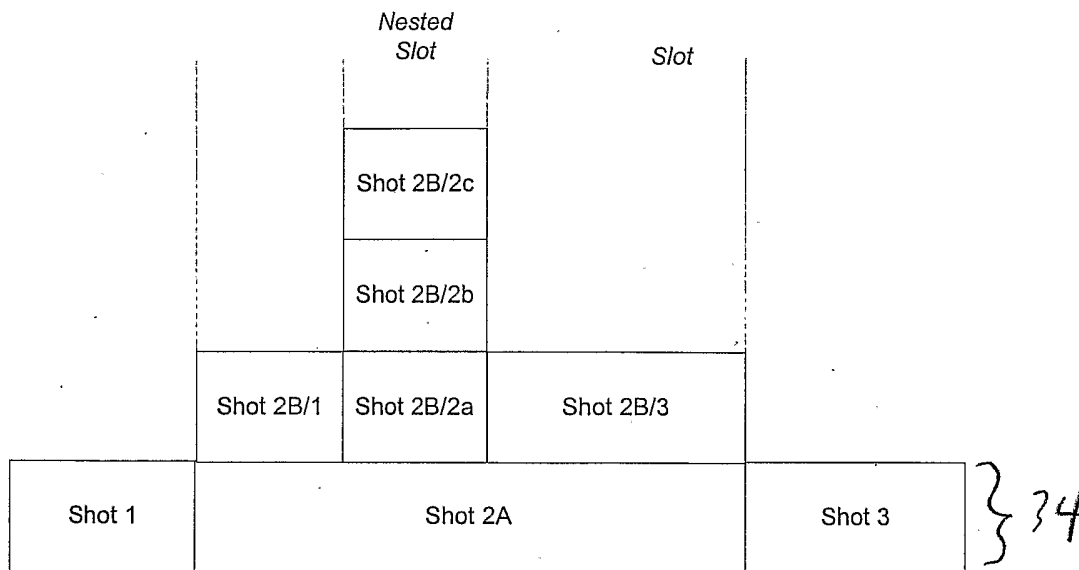

Fig. 5

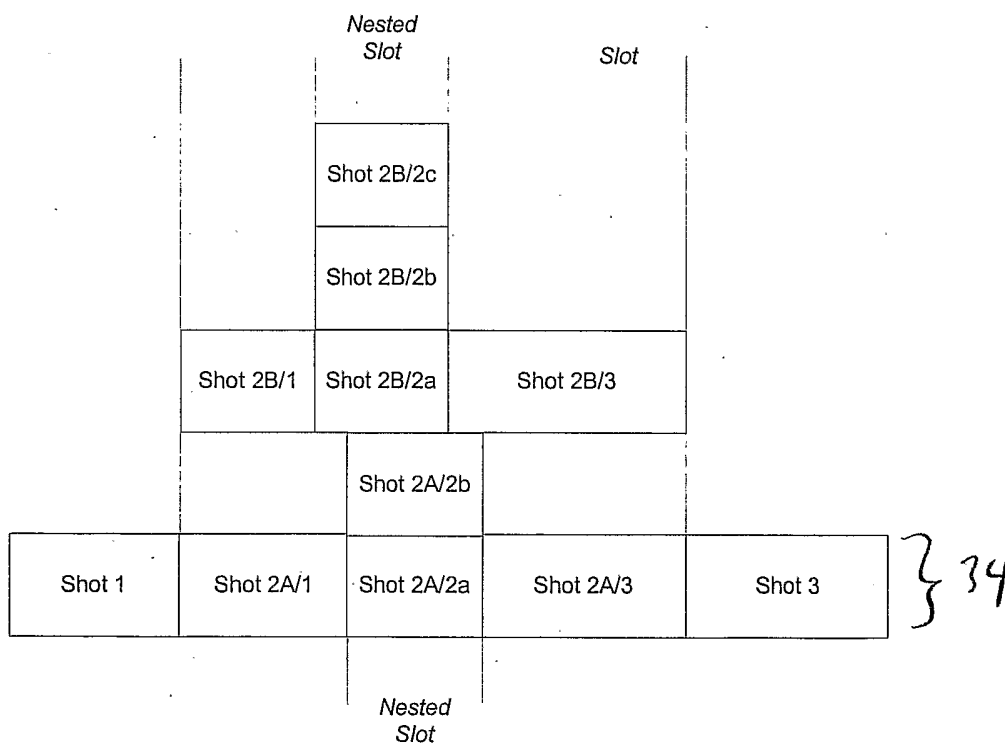

Fig. 6

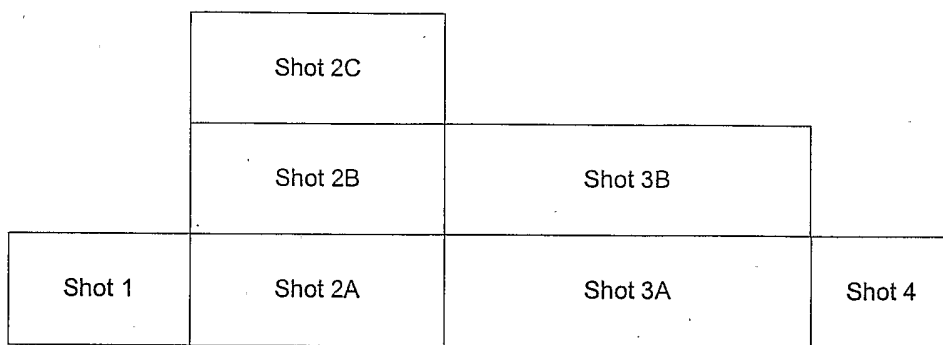

Fig. 7

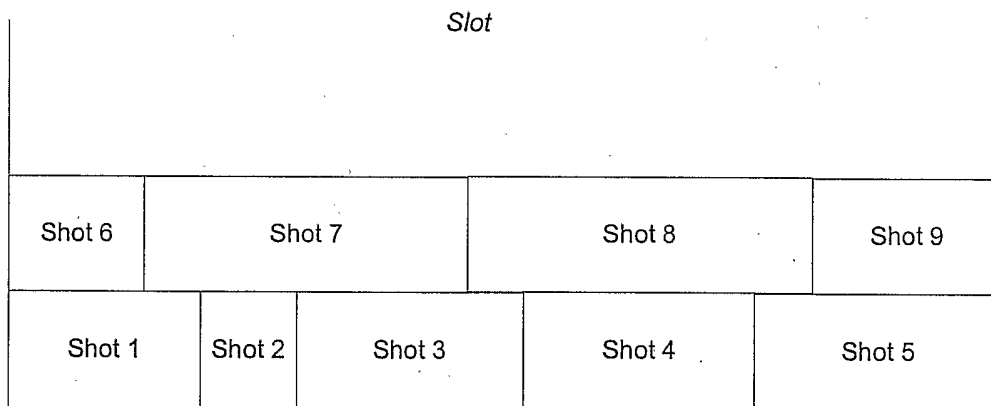

Fig. 8

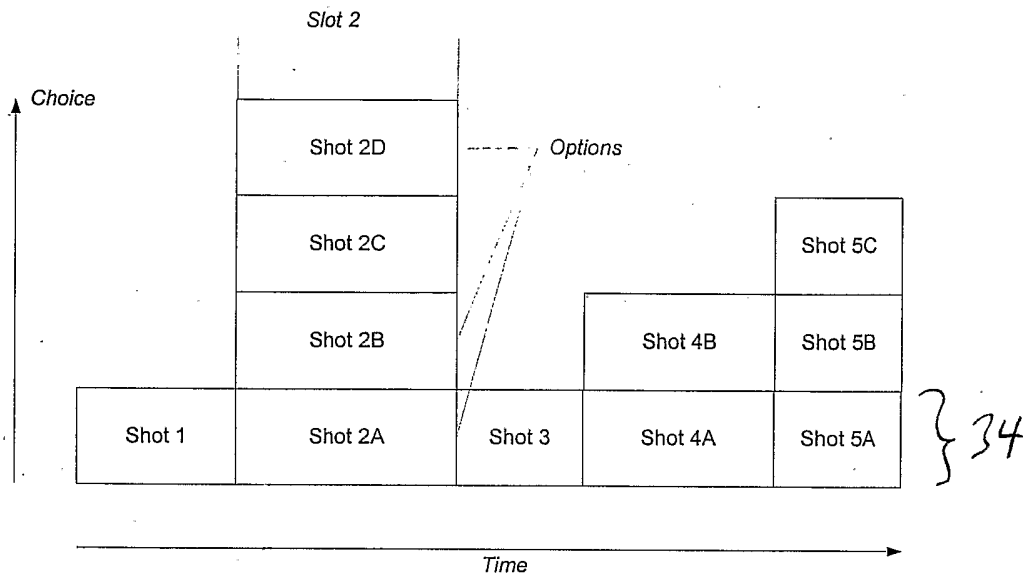

Fig. 3

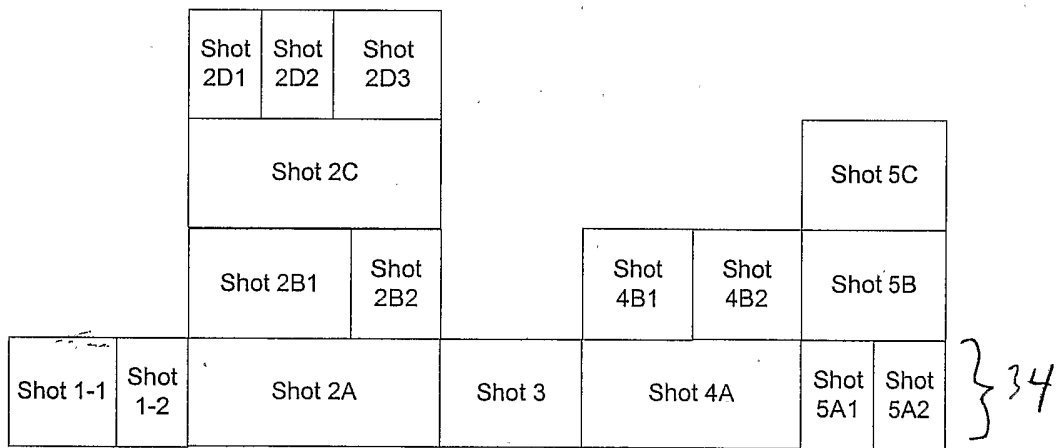

Fig. 4

36

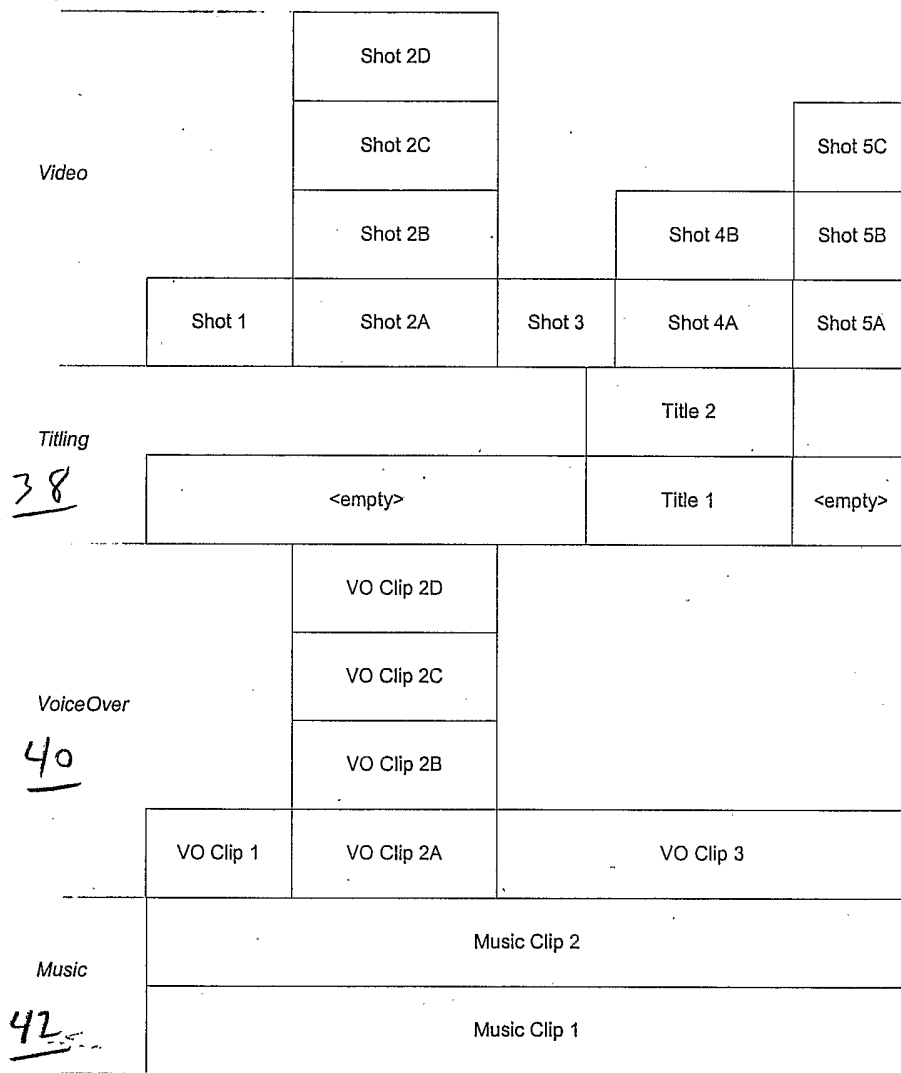

Fig. 9

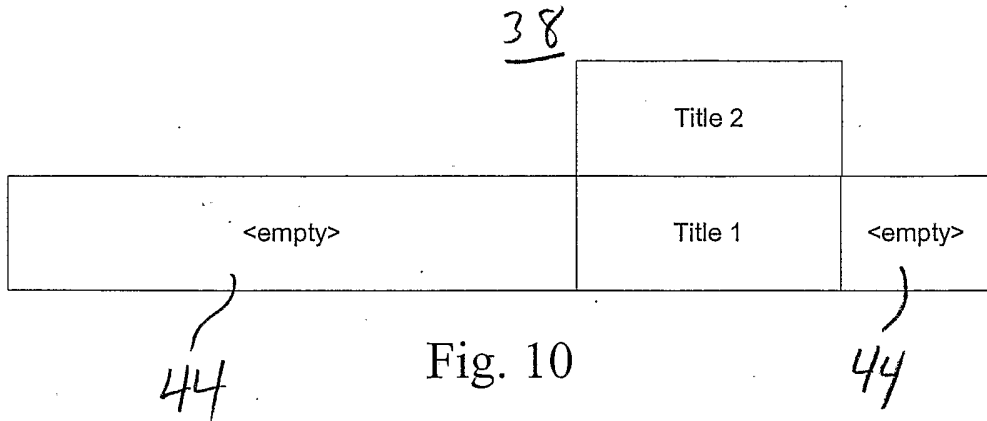

Fig. 10

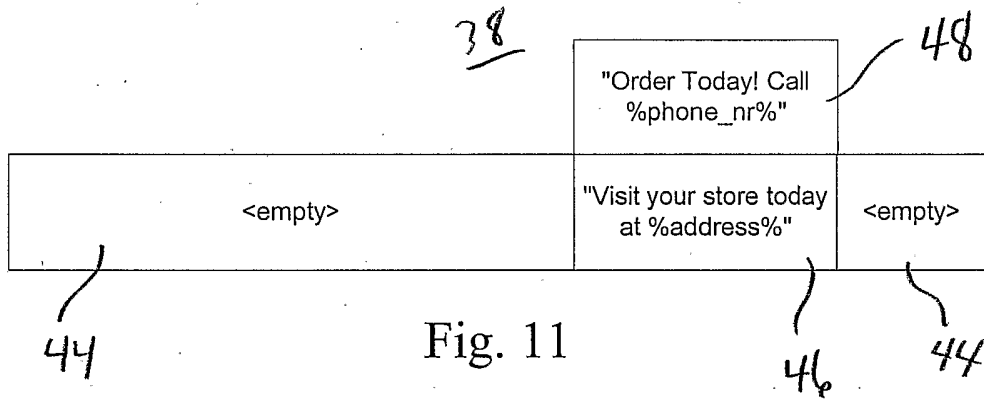

Fig. 11

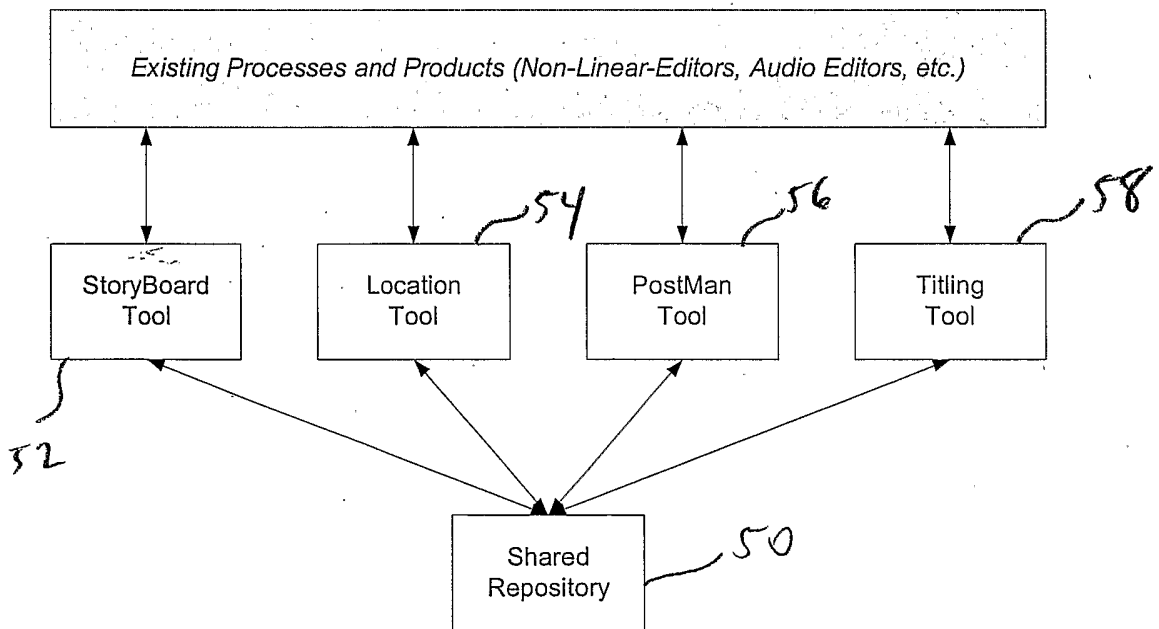

Fig. 12

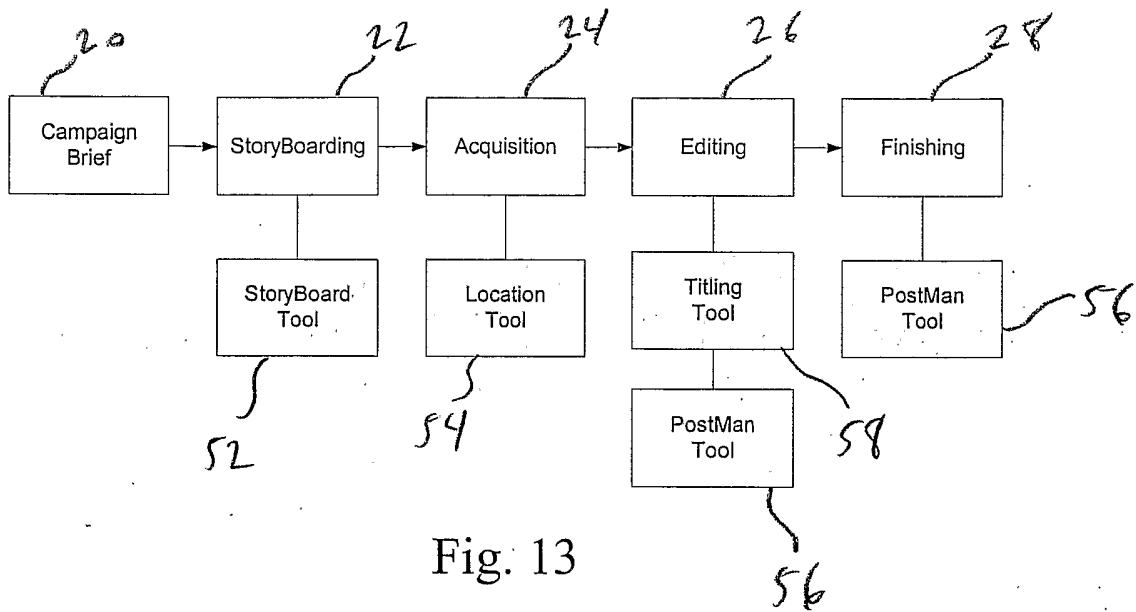

Fig. 13

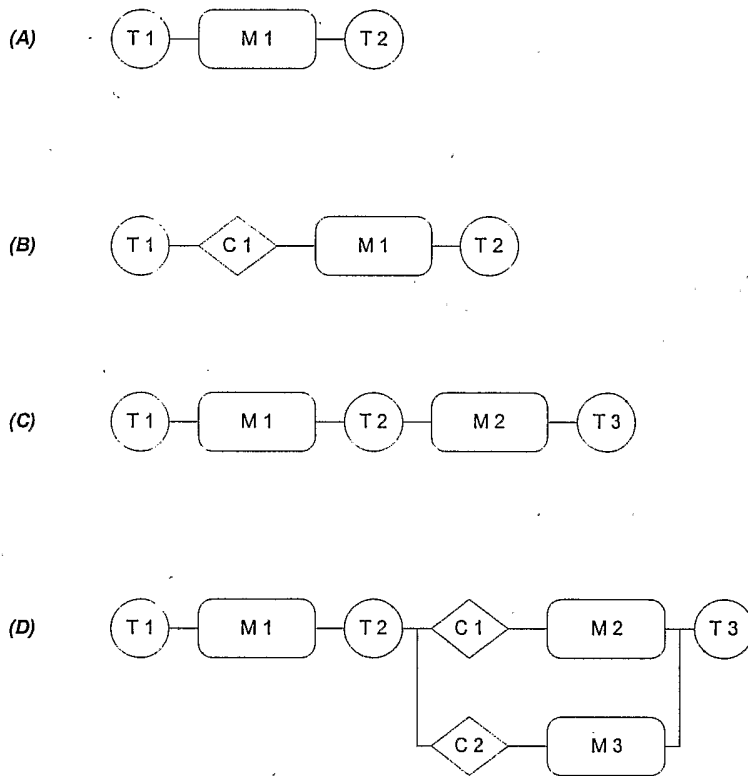

Fig. 14

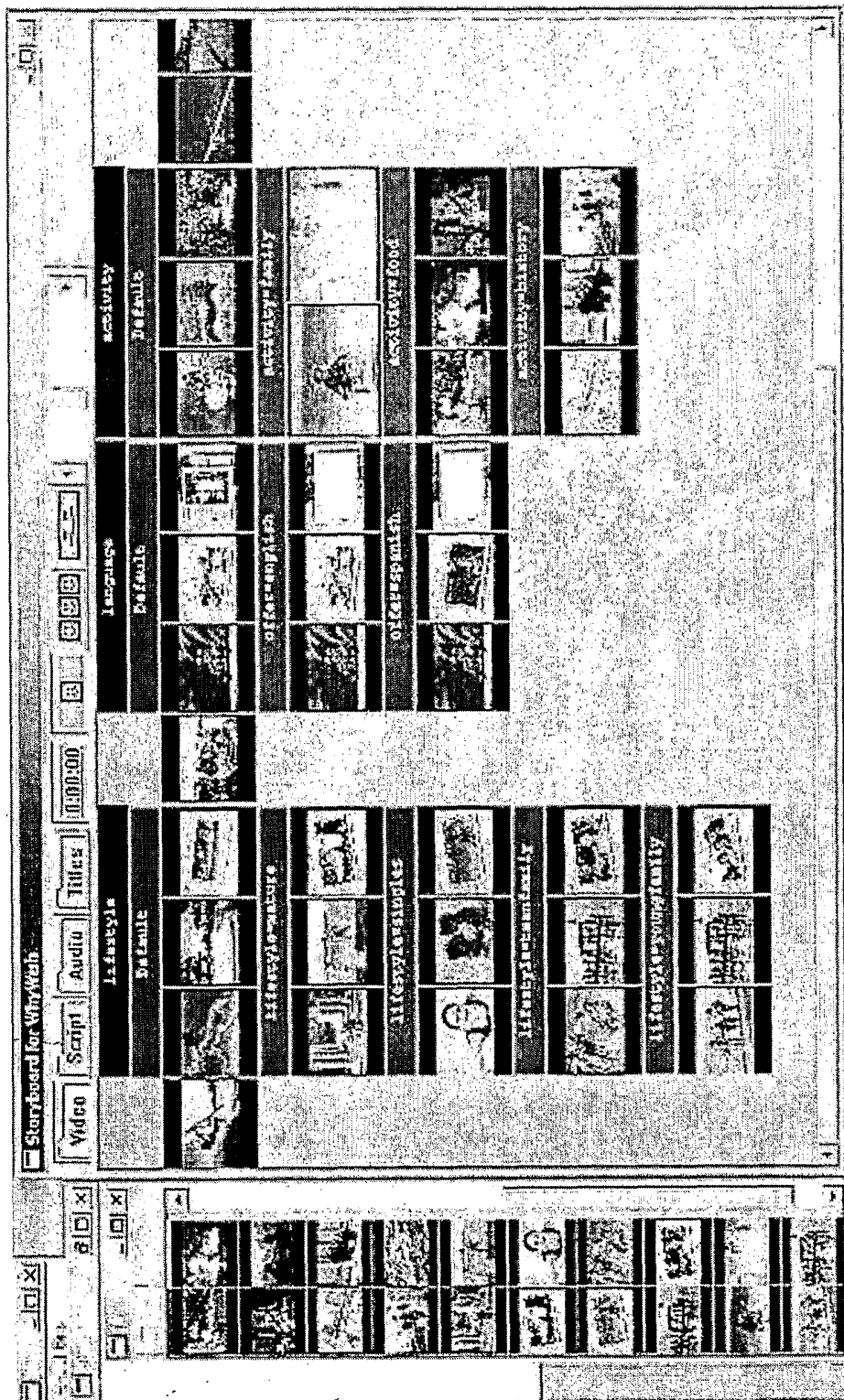

Fig. 15

