

D. A. Dickinson,
Turning Irregular Forms.

N^o 42,991.

Patented May 31, 1864.

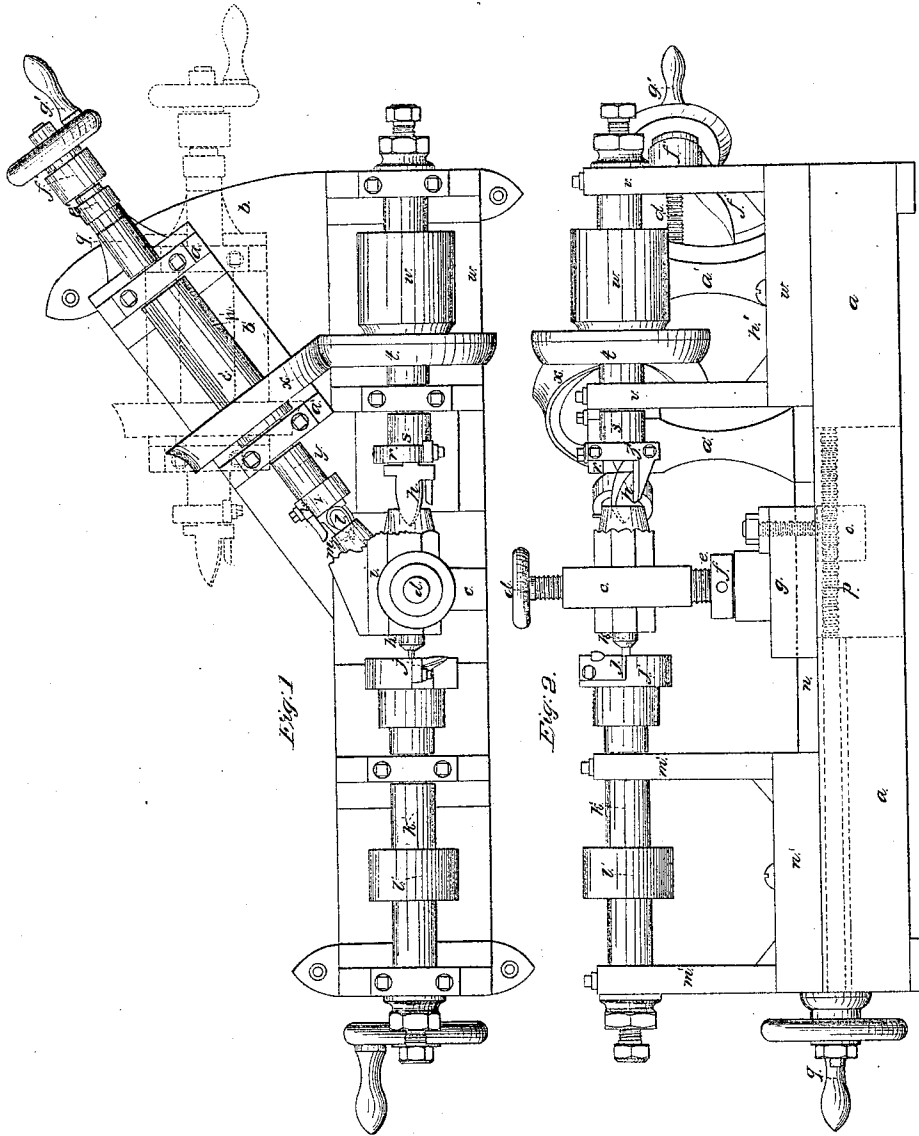

Witnesses:
A. C. Lambright,
J. Smith,

Inventor:
D. A. Dickinson,
by Atty J. T. Everett.

UNITED STATES PATENT OFFICE.

DAVID A. DICKINSON, OF BALTIMORE, MARYLAND, ASSIGNOR TO TOBACCO PIPE COMPANY, OF SAME PLACE.

IMPROVEMENT IN MACHINES FOR MAKING TOBACCO-PIPES.

Specification forming part of Letters Patent No. 42,991, dated May 31, 1864.

To all whom it may concern:

Be it known that I, DAVID A. DICKINSON, of the city of Baltimore and State of Maryland, have invented a certain new and useful Improvement in Machines for making Tobacco-Pipes; and I do hereby declare that the following is a full, clear, and exact description of the construction and operation of the same, reference being had to the accompanying drawings, and to the letters and marks thereon.

The machine that is made the subject of this application for a patent is more especially intended to be used in making the double-tubed tobacco-pipes as set forth in Letters Patent which were granted to A. J. and L. K. Bowen, assignees of the said A. J. Bowen, on the 10th day of June, 1862; but, like all machines of this character, this machine may be used in making other tobacco-pipes, which in general are formed or constructed similar to the Bowen pipe.

The part of the pipe designed to be formed by this machine is the bowl or body, with a prolongation of the bottom for the attachment of a cup or receptacle, and a side projecting tube for the reception of the stem, the whole being made from one block or blank.

The drawings forming part of this specification represent by Figure 1 a top view of this machine, and by Fig. 2 a side view thereof.

In each of these figures, where like parts are shown, like marks and letters are used to indicate the parts.

The several parts of the machine rest upon or are attached to a common base or platform, *a*, which is of rectangular form, widened out at one end, *b*, for the support of one of the tools and its shaft. The clamp or blank holder *c*, having a clamping-screw, *d*, is by a screw-shank, *e*, and clamping-nut *f* affixed to a plate, *g*, the position of the clamp being between the tools *h* for acting upon the end of the blank or block *i*, to form the bowl and the tools *j* to form the projection *k* on the bottom of the body of the pipe for the attachment of a cup or receptacle. The tools *l* for forming the tube *m* for the stem of the pipe are on the widened-out part *b* of the platform. The plate *g* embraces a plate, *n*, on which it can travel, a projecting nut, *o*, of plate *g* being operated upon by a screw-rod, *p*, the handle or crank of which is marked *q*,

the rod passing along and through the end of the base-plate, as is shown by Fig. 2.

The tools *h* for forming the bowl of the pipe consist of a central borer and a cutter or trimmer, and are affixed to a tool-head, *r*, on a shaft, *s*, having a friction-wheel, *t*, and a pulley, *u*, the said shaft *s* having suitable bearings in the standards *v* of the plate *w*. This shaft *s* will derive its rotation from a band from a general power-shaft passed around the pulley *u*. The friction-wheel *t* will give motion, when in contact, to another friction-wheel, *x*, on the shaft *y* of the tool-head *z*, having the tools *l*. Instead of friction-wheels, toothed wheels may be used, if deemed preferable. The tools *l* on the shaft *y* are also a central borer and trimmer, and these tools, as well as the tools on the other shafts, are attached to the tool-heads by plates or extension-pieces *z'* and screws, so that they may readily be detached for repairs, &c., and other tools larger or smaller and fitted nearer to or farther out from the shaft take their places. The shaft *y* has suitable bearings in standards *a'* of the plate *b'*. It will be noticed that the friction-wheel *x* is on a collar, *c'*, having the usual feather for allowing the shaft to slide through the collar but to rotate with it. The shaft *y* can be moved backward and forward by means of the screw *d'*, passing through an arm-nut, *e'*, on the end of the shaft, the screw being supported by the arm *f'* and the standard *a'*, and having a crank or handle, *g'*, and thus the tools of this shaft can be made to work deeper or shallower. The plate *b'* is pivoted at *h'* to the base-piece *b*, so that the shaft and its pieces or parts can be turned out to a greater or less extent, as indicated by red lines in Fig. 1, and thus make the tube *m* at a greater or less angle than is shown by drawings as may be needed. The tools *j* are a small central borer and cutter or trimmer attached to a tool-head, *j'*, on the shaft *k'*, which has a pulley, *l'*, for a band to give the shaft rotation, and suitable standards, *m'*, for bearings affixed to a plate, *n'*.

From this description of the construction of the machine its operation will readily be understood. The clamp or blank-holder being about midway between the two tools *h* and *j*, a blank or block of suitable size is placed therein, and the tool-shafts being in ro-

tation, by turning the screw *p* the blank is first moved up to the tools *k* and *l*, or to the tools *j*, and then moved up to the other tools, and the blank quickly transformed into the body for the pipe, needing only the external working off, which is done by other tools and machinery.

What I claim as an improvement on machines for turning and boring tobacco-pipes is—

The arrangement of the clamp or blank-holder and the tools with their shafts in their relation to each other and operating as herein recited.

This specification signed this 11th day of January, 1864.

D. A. DICKINSON.

Witnesses:

THOS. T. EVERETT,
T. SMITH.