

(19)



Europäisches Patentamt

European Patent Office

Office européen des brevets



(11)

EP 0 580 844 B1

(12)

EUROPEAN PATENT SPECIFICATION

(45) Date of publication and mention of the grant of the patent:

20.05.1998 Bulletin 1998/21

(51) Int. Cl.⁶: **B65D 75/00**, B65D 71/36, B65D 75/56

(21) Application number: **93904964.9**

(86) International application number: **PCT/US93/01097**

(22) Date of filing: **08.02.1993**

(87) International publication number: **WO 93/15971 (19.08.1993 Gazette 1993/20)**

(54) CARRIER FOR STACKED ARTICLES

TRÄGER FÜR GESTAPELTE GEGENSTÄNDE

DISPOSITIF DE TRANSPORT D'ARTICLES EMPILES

(84) Designated Contracting States:
AT BE CH DE DK ES FR GB GR IE IT LI LU MC NL PT SE

(30) Priority: **11.02.1992 US 834892**

(43) Date of publication of application:
02.02.1994 Bulletin 1994/05

(73) Proprietor:
**RIVERWOOD INTERNATIONAL CORPORATION
Atlanta, Georgia 30339 (US)**

(72) Inventors:
• **SCHUSTER, Richard, Lee
Monroe, LA 71292 (US)**

• **BOROCZ, Joseph, Anthony
Marietta, GA 30060 (US)**

(74) Representative:
**Grättinger & Partner (GbR)
Postfach 16 55
82306 Starnberg (DE)**

(56) References cited:
**US-A- 1 469 797 US-A- 1 850 714
US-A- 2 124 808 US-A- 2 874 869
US-A- 3 351 264 US-A- 3 904 036
US-A- 3 994 432 US-A- 4 121 757
US-A- 4 331 289 US-A- 4 478 334
US-A- 4 546 914 US-A- 4 558 084
US-A- 4 785 991 US-A- 4 816 014
US-A- 4 830 267 US-A- 4 846 395**

EP 0 580 844 B1

Note: Within nine months from the publication of the mention of the grant of the European patent, any person may give notice to the European Patent Office of opposition to the European patent granted. Notice of opposition shall be filed in a written reasoned statement. It shall not be deemed to have been filed until the opposition fee has been paid. (Art. 99(1) European Patent Convention).

Description

Field of the Invention

This invention relates to an article carrier containing a plurality of articles as defined in the preamble of claim 1.

Background of the Invention

Sleeve-type carriers are commonly used to package beverage cans and other types of articles, and are typically formed from paperboard blanks which have been folded into collapsed sleeve form. Each collapsed sleeve is opened by a packaging machine, after which cans or other articles are introduced through one or both the open ends of the sleeve and the end panel flaps are folded and secured together. The cans are normally introduced in upright position while the carrier sleeve is supported on one of its side panels, with the open ends of the sleeve facing out to receive the cans. The resulting carrier therefore contains a layer of cans the ends of which are located adjacent the side panels of the carrier. Additionally, a handle is normally incorporated into the top panel of the carrier to facilitate lifting and carrying.

A carrier of this type corresponding to the preamble of claim 1 is disclosed for example in US-A-3994432. Although such carriers have been designed to contain varying numbers of articles, conventional packages for carrying beverage cans normally hold six or twelve cans. This is partly because a conventional sleeve-type carrier would be quite long when made large enough to handle large numbers of cans, such as twenty-four, and would be unwieldy to carry. Further, the heavy load caused by the cans would tend to promote tearing in the handle area.

US-A-3351264 discloses a carrier for a larger number of articles such as 24 cans. The cans are arranged in two layers in end to end relationship. A sheet-like packaging device is interposed between every two adjacent layers of cans for separating and maintaining superposed cans from each other while preventing lateral shifting of such cans. This document, however, does not address the problem of providing a sufficiently strong handle resisting tearing when the carrier is lifted.

US-A-3904036 discloses a fully enclosed bottle carrier. This carrier is designed to carry the bottles standing upright on the bottom panel. The side panels comprise a lower vertical section and an upper tapered section; and the top panel is narrower than the bottom panel. In order to provide for collapsing of a pre-glued sleeve, a so-called false score is formed in the bottom panel. The top panel flaps of this carrier comprise stress relief lines extending from the ends of the respective handle opening to the adjacent side panel.

Taking into consideration the above-mentioned

drawbacks of the generic prior art, it would be highly advantageous to have a sleeve-type carrier capable of holding a large number of articles, and capable of resisting tearing when lifted and carried. It is an object of the invention to provide such a carrier.

Brief Summary of the Invention

This object is achieved by a carrier according to claim 1. The carrier of the invention, which achieves the goal set out above, is designed to receive a plurality of layers of stacked articles. Thus, instead of the usual single layer of articles arranged with their ends adjacent the side panels of the carrier, the invention incorporates a plurality of layers of articles, with the ends of the articles in one layer being adjacent the ends of the articles in the next layer. Moreover, the ends of the articles in the end layers are adjacent the top and bottom panels instead of the side panels. This results in the ability to carry more articles by only slightly increasing the overall dimensions of the carrier and lends itself to the use of a carrier handle which is capable of withstanding the increased load.

The top panel of the carrier is comprised of an inner flap connected to the upper edge of one of the side panels along a fold line and an outer flap connected to the upper edge of the other side panel. Each of the inner and outer flaps has an edge remote from the side panels and each flap contains a handle opening spaced from the remote edge thereof. The outer flap overlaps the inner flap to form an area of double thickness extending between the handle openings. The resulting suitcase style handle facilitates carrying the slightly wider package of the invention. Reinforcing means are provided in the area of double thickness for reinforcing the area against tearing. The reinforcing means comprises a sheet adhered to the underside of the inner top panel flap, the sheet including a folded edge substantially aligned with and underlying the edge of the handle opening in the outer top panel flap nearest the remote edge of the outer top panel flap.

In a preferred embodiment stress relief lines are provided in the top panel extending outwardly from the handle openings to distribute lifting stresses. Preferably, the stress relief lines comprise score lines extending from each handle opening to the nearest side panel, preferably to the corners of the top panel.

Further, the end panels are comprised of end flaps foldably connected to the top, bottom and side panels, of which the end flaps connected to the top panel preferably comprise two overlapped flaps segments, whereby the overlapped flaps comprise an extension of the overlapped top panel flaps.

Due to the stacked arrangement of the articles in the carrier, the carrier is of a shape and size which makes lifting by means of the handle a relatively simple task, even though the contents of the carrier may be quite heavy.

These and other features and aspects of the invention, as well as other benefits, will readily be ascertained from the detailed description of the preferred embodiment described below.

Brief Description of the Drawing

FIG. 1 is a pictorial view of the carrier of the invention;

FIG. 2 is a vertical sectional view taken along line 2-2 of FIG. 1;

FIG. 3 is a plan view of the carrier of FIG. 1;

FIG. 4 is a plan view of a blank for fabricating the carrier of FIG. 1;

FIG. 5 is an enlarged sectional view of the area enclosed by the oval 5 in FIG. 2; and

FIG. 6 is a pictorial view of the carrier of the invention illustrating the distortion of the top panel while being lifted or carried.

Detailed Description of the Preferred Embodiment

Referring to FIG. 1 of the drawing, the carrier 10 is comprised of side panels 12 foldably connected to top panel 14 and to the bottom panel, not visible in this view. The top panel is comprised of two top panel flaps 16 and 18, described more fully below. End panels 20 connect the top, bottom and side panels and are comprised of end panel flaps 22 and 24 adhered to dust flaps 26 and 28, wherein the end panel flaps are foldably connected to the top and bottom panels and the dust flaps are foldably connected to the side panels. Spaced handle openings 30 and 32 are provided in the top panel and extend along the length of the carrier substantially parallel to the side panels. Score lines 34 extend from the ends of handle opening 30 to the nearest corners of the carrier, while score lines 36 extend from the ends of handle opening 32 to the other corners of the carrier.

As shown in FIGS. 2 and 3, the carrier contains a bottom layer of articles, shown for purpose of illustration as beverage cans C1, and an upper layer of articles, shown as cans C2, in stacked relationship. The lower ends of the upper cans C2 thus are supported on the upper ends of the bottom cans C1, with the bottom cans resting on the bottom panel 38. The top panel 14 is closely adjacent, and preferably is in contact with, the tops of the cans C2 to provide for a tight fit between the cans and the carrier. As shown in FIG. 3, the top layer of cans is made up of twelve cans arranged in three rows of four cans. Since the bottom layer is identically arranged, the total number of cans in the carrier is twenty-four. As illustrated in FIG. 2, the top panel is reinforced between the handle openings as indicated by numeral 40, the details of which are explained hereinafter.

Referring now to FIG. 4, the carrier 10 of FIG. 1 is formed from the blank 42, wherein portions corresponding to similar elements of the carrier are identified by the

same reference numerals. The blank 42 is a single sheet of material, preferably paperboard, comprising a centrally located bottom panel section 38 connected to the side panel sections 12 along fold lines 44. The outer top panel flap 16 is connected to one of the side panel sections 12 along fold line 46, while the inner top panel flap 18 is connected to the other side panel section 12 along fold line 48. End panel flaps 24 are connected to the bottom panel section 38 along fold lines 50, and end panel flaps 22 are connected to the outer and inner top panel flaps 16 and 18 along fold lines 52 and 54, respectively. Inner or dust flaps 26 and 28 are connected to the side panel sections 12 along fold lines 55 and 57, respectively. In addition, the reinforcing means 40 of FIG. 2 comprises a sheet adhered to the inner top panel flap 18 so as to terminate at the free edge 56 of the inner top panel flap. It is preferred that the reinforcing sheet entirely cover the area which includes the handle opening 32, requiring the sheet to have a corresponding cutout 58 to enable the fingers of a user to penetrate the top panel when lifting the carrier, but in any event the sheet should at least extend to the outer edge of the cutout 32 in order to provide extra thickness in the handle strap portion. It will be appreciated that the inner surface of the blank is facing the viewer in FIG. 4 and that the reinforcing sheet is on the inner surface of the inner top panel flap.

Fabrication of the carrier is by standard means, with the blank being folded along the fold lines 44, 46 and 48 to bring the top panel flaps 16 and 18 together and then overlapping and gluing the top panel flaps in the stippled area 60 of the blank of FIG. 4. The end panel flaps 22 extending from the outer top panel flap 16 are thus adhered to the end panel flaps 22 extending from the inner top panel flap 18 to form the upper end panel flaps extending from the top panel. The end panels are formed in the usual manner by first folding the dust flaps 26 and 28 and then the end panel flaps down and gluing the end panel flaps to the dust flaps.

As shown in FIG. 5, the reinforcing sheet 40 preferably is comprised of a thinner sheet than the material from which the carrier is formed, and is folded over upon itself to provide a fold 62. The fold 62 is aligned with the edge 56 of the inner top panel flap 18, and both are aligned with the inner edge 64 of the cutout 30. This edge is referred to in the claims as the remote side edge of the cutout 30, referring to the arrangement whereby this edge of the cutout is farthest from the side panel to which the inner top panel flap 18 is connected. This design strengthens the strap portion due to the extra thickness of material in this region and also prevents tearing along the cutout edge 64 as well as in areas of the top panel flap 16 which would normally be at risk to a tear originating at this critical juncture in the handle area. This is thought to be due to the fact that a fold acts as a surface rather than an edge, and just as it is considerably more difficult to initiate a tear at a surface than at an edge, the folded reinforcement strip makes it diffi-

cult to initiate a tear along this lifting edge of the handle opening. This design additionally provides a cushioning effect for the hand of a user. For purpose of illustration the thickness of the carrier material has been exaggerated. It will be understood, therefore, that in actual practice the thickness of the strap portion of the handle between the openings 30 and 32 will not be as great with respect to the height of the cans as shown, and the top panel flaps 16 and 18 will be in contact with more, if not all, of the top surface of adjacent cans.

As will be appreciated, there is little room for the fingers of a user to maneuver when trying to get a grip on the handle strap due to the close proximity of the tops of the cans to the top panel. The design of the invention anticipates upward movement of the top panel as the fingers pull up on the handle while first gripping the strap portion and during lifting and carrying. As shown in FIG. 6, the top panel is adapted to smoothly bow upwardly without tearing at critical areas which normally receive most of the lifting stresses. This is accomplished by the stress relief score lines 34 and 36 which extend from the ends of the handle cutouts to the side panels. Preferably, as illustrated, these lines extend to the corners of the package, thereby transmitting the lifting stresses to the corner folds.

The benefit of the carrier design of the invention can be better understood by comparing a carrier of the invention which is adapted to carry 24 standard 12-fluid ounce beverage cans to a sleeve-type carrier adapted to carry only 12 of the same cans. In the 12-can prior art carrier the cans are arranged with their ends against the side panels in three rows of four cans each. The length of the package is thus approximately equal to four can diameters, the height to three can diameters and the width to one can length. In the 24-can carrier of the invention the cans are arranged with their ends against the top and bottom panels in two stacked layers, each layer being made up of three rows of four cans each. The length of this package is thus approximately equal to four can diameters, the same as the length of the prior art 12-can package. The height of the package is approximately equal to two can lengths and the width of the package is approximately equal to three can diameters. In terms of actual dimensions, this would mean that for a package of the same length as the prior art 12-pack package, a height of only about two inches more and a width of less than three inches more results in twice the carrying capacity. Additional layers of cans or other articles could be packaged simply by making the height of the carrier an additional article length greater.

The handle reinforcement afforded by the suitcase type of handle illustrated in the preferred embodiment resists tearing in this critical area, and the stress relief lines distribute the lifting and carrying stresses from the handle area to the sides, preferably to the corner folds of the carrier. The overlapped portion of the top panel extends beyond the handle area to the ends of the top panel and beyond the top panel through the upper end

panel flaps connected to the top panel. This increases the strength of the end panel flaps which in turn increases the strength of the end panels, allowing them to better resist the lifting stresses which may be distributed to them via the stress relief lines.

Although a specific carrier design has been disclosed which is economical to fabricate and is capable of increasing the carrying capacity over prior art carriers while only slightly increasing the carrier size, it will be understood that changes to certain features and aspects of the design which do not affect the overall basic function and concept of the invention may be made by those skilled in the art without departing from the scope of the invention, as defined by the appended claims.

Claims

1. An article carrier (10) containing a plurality of articles (C1, C2), comprising:

two side panels (12) having upper (46, 48) and lower (44) edges;
 a bottom panel (38) connected to the lower edges of the side panels;
 a top panel (14) connected to the top edges of the side panels (12);
 the top panel (14) being comprised of an inner flap (18) connected to the upper edge of one of the side panels (12) along a fold line (48) and an outer flap (16) connected to the upper edge of the other side panel (12) along a fold line (46);
 end panels (20) connected to the top (14), bottom (38) and side (12) panels;
 each inner (18) and outer (16) top panel flap having an edge remote from the side panels (12) and each said flap containing a handle opening (30, 32) spaced from the remote edge of said flap, the outer top panel flap (16) overlapping the inner top panel flap (18) to form an area of double thickness, said area extending between the handle openings (30, 32);
 characterized by reinforcing means (40) in the area of double thickness for reinforcing said area against tearing, the reinforcing means comprising a sheet adhered to the underside of the inner top panel flap (18), the sheet including a folded edge (62) substantially aligned with and underlying the edge (56) of the handle opening (30) in the outer top panel flap (16) nearest the remote edge of the outer top panel flap, the sheet being of less thickness than the thickness of the top panel flaps;
 the plurality of articles being arranged in a plurality of layers of stacked articles, the plurality of layers of articles having top and bottom ends, the articles of each layer being arranged

in stacked end-to-end relationship with articles in the next adjacent layer, the bottom ends of the articles in the lowermost layer contacting the bottom panel (38) of the carrier and the top ends of the articles in the uppermost layer being adjacent the top panel (19) of the carrier when the carrier is resting on the bottom panel.

2. The carrier of claim 1, wherein each flap of the top panel includes stress relief lines (34, 36) extending from the ends of the handle opening (30, 32) therein to the side panel (12) nearest thereto to distribute lifting stresses outwardly from the handle openings.
3. The carrier of claim 1, wherein each end panel (20) comprises end flaps (22, 24, 26, 28) foldably connected to the top, bottom and side panels, the end flap connected to the top panel (14) comprising two overlapped flaps (22), one of the two overlapped flaps (22) extending from the inner top panel flap (18) and the other of the two overlapped flaps extending from the outer top panel flap (16), the overlapped flaps being adhered together by adhesive.
4. The carrier of claim 1, wherein the articles are beverage cans (C) arranged in two layers, the cans in each layer being arranged in rows parallel to the side panels (12) and rows parallel to the end panels (20), the number of cans in the rows parallel to the side panels being one or more than the number of cans in the rows parallel to the end panels.

Patentansprüche

1. Träger (10) für Gegenstände, der eine Vielzahl von Gegenständen (C1, C2) enthält und folgendes umfaßt:

zwei Seitenwände (12), die obere (46, 48) und untere (44) Kanten aufweisen;
 eine Bodenwand (38), die mit den unteren Kanten der Seitenwände verbunden ist;
 eine Deckelwand (14), die mit den oberen Kanten der Seitenwände (12) verbunden ist;
 wobei die Deckelwand (14) aus einer entlang einer Faltlinie (48) mit der oberen Kante einer der Seitenwände (12) verbundenen inneren Klappe (18) und einer entlang einer Faltlinie (46) mit der oberen Kante der anderen Seitenwand (12) verbundenen äußeren Klappe (16) besteht;
 Endwände (20), die mit der Deckelwand (14), der Bodenwand (38) und den Seitenwänden (12) verbunden sind;
 wobei jede innere (18) und äußere (16) Deckelwandklappe eine Kante hat, die entfernt von

den Seitenwänden (12) liegt, und jede der Deckelwandklappen jeweils eine Grifföffnung (30, 32) enthält, die mit Abstand von der entfernten Kante der Klappe angeordnet ist, wobei die äußere Deckelwandklappe (16) die innere Deckelwandklappe (18) überlappt, um einen Bereich doppelter Dicke zu bilden, der sich zwischen den Grifföffnungen (30, 32) erstreckt; dadurch gekennzeichnet,

daß Verstärkungsmittel (40) in dem Bereich doppelter Dicke vorgesehen sind, um diesen Bereich gegen Zerreißen zu verstärken, wobei die Verstärkungsmittel ein Flachmaterial umfassen, das an der Unterseite der inneren Deckelwandklappe (18) befestigt ist und das eine gefaltete Kante (62) umfaßt, die im wesentlichen mit der Kante (56) der Grifföffnung (30) in der äußeren Deckelwandklappe (16), die der entfernten Kante der äußeren Deckelwandklappe am nächsten liegt, ausgerichtet ist und unter dieser liegt, wobei das Flachmaterial weniger dick ist als die Deckelwandklappen;

wobei die Vielzahl von Gegenständen in einer Vielzahl von Schichten von gestapelten Gegenständen angeordnet ist, wobei die Vielzahl von Schichten von Gegenständen obere und untere Enden haben und die Gegenstände jeder Schicht Ende an Ende mit Gegenständen in der angrenzenden Schicht gestapelt sind, wobei die unteren Enden von Gegenständen in der untersten Schicht die Bodenwand (38) des Trägers berühren und die oberen Enden der Gegenstände in der obersten Schicht an der Deckelwand (19) des Trägers anliegen, wenn der Träger auf der Bodenwand ruht.

2. Träger nach Anspruch 1, dadurch gekennzeichnet, daß jede Deckelwandklappe Entlastungslinien (34, 36) enthält, die sich von den Enden der Grifföffnung (30, 32) zu der nächstgelegenen Seitenwand (12) erstrecken, um Hebelbelastungen von der Grifföffnung nach außen zu verteilen.
3. Träger nach Anspruch 1, dadurch gekennzeichnet, daß jede Endwand (20) Endklappen (22, 24, 26, 28) umfaßt, die faltbar mit den Deckel-, Boden- und Seitenwänden verbunden sind, wobei die mit der Deckelwand (14) verbundene Endklappe zwei sich überlappende Klappen (22) umfaßt, von denen sich eine von der inneren Deckelwandklappe (18) und die andere von der äußeren Deckelwandklappe (16) erstreckt und die mit Klebstoff aneinandergelastet sind.
4. Träger nach Anspruch 1,

dadurch gekennzeichnet,
daß die Gegenstände Getränkedosen (C) sind, die
in zwei Schichten angeordnet sind, wobei die
Dosen in jeder Schicht in Reihen parallel zu den
Seitenwänden (12) und in Reihen parallel zu den
Endwänden (20) verlaufen und die Anzahl der
Dosen in den Reihen parallel zu den Seitenwänden
gleich oder größer ist als die Anzahl der Dosen in
den Reihen parallel zu den Endwänden.

5

10

Revendications

1. Support d'objets (10) contenant plusieurs objets
(C1, C2), comprenant :

deux panneaux latéraux (12) ayant des bords
supérieurs (46, 48) et des bords inférieurs (44)

;

un panneau de fond (38) relié aux bords infé-
rieurs des panneaux latéraux ;

un panneau supérieur (14) relié aux bords
supérieurs des panneaux latéraux (12) ;

le panneau supérieur (14) étant constitué d'un
rabat intérieur (18) relié au bord supérieur de
l'un des panneaux latéraux (12) le long d'une
ligne de pliage (48) et un rabat extérieur (16)
relié au bord supérieur de l'autre panneau laté-
ral (12) le long d'une ligne de pliage (46) ;

des panneaux d'extrémité (20) reliés aux pan-
neaux supérieur (14), de fond (38) et latéraux
(12) ;

chaque rabat intérieur (18) et extérieur (16) de
panneau supérieur ayant un bord distant des
panneaux latéraux (12) et chacun desdits
rabats comportant un trou de poignée (30, 32)
placé à distance du bord distant dudit rabat, le
rabat extérieur de panneau supérieur (16) che-
vauchant le rabat intérieur de panneau supé-
rieur (18) de manière à former une zone
d'épaisseur double, ladite zone étant située
entre les trous de poignée (30, 32) ;

caractérisé par un moyen de renfort (40)
situé dans la zone d'épaisseur double pour ren-
forcer ladite zone contre le déchirement, le
moyen de renfort comportant une feuille collée
au côté inférieur du rabat intérieur de panneau
supérieur (18), la feuille comprenant un bord
plié (62) sensiblement aligné sur et sous-jacent
au bord (56) du trou de poignée (30) du rabat
extérieur de panneau supérieur (16) qui est le
plus proche du bord distant du rabat extérieur
de panneau supérieur, la feuille ayant une
épaisseur inférieure à l'épaisseur des rabats
de panneau supérieur ;

les plusieurs objets étant disposés en plusieurs
couches d'objets empilés, les plusieurs cou-
ches d'objets ayant des extrémités supérieure
et inférieure, les objets de chaque couche étant

15

20

25

30

35

40

45

50

55

disposés en relation d'empilement bout à bout
avec les objets de la couche voisine suivante,
les extrémités inférieures des objets de la cou-
che inférieure étant en contact avec le pan-
neau de fond (38) du support et les extrémités
supérieures des objets de la couche supé-
rieure étant voisines du panneau supérieur
(19) du support lorsque le support repose sur
le panneau de fond.

2. Support selon la revendication 1, dans lequel cha-
que rabat du panneau supérieur comprend des
lignes de soulagement des efforts (34, 36) allant
des extrémités du trou de poignée (30, 32) qu'il
comporte au panneau latéral (12) qui lui est le plus
proche pour distribuer les efforts de soulèvement
vers l'extérieur des trous de poignée.

3. Support selon la revendication 1, dans lequel cha-
que panneau d'extrémité (20) comprend des rabats
d'extrémité (22, 24, 26, 28) reliés par pliure aux
panneaux supérieur, de fond et latéraux, le rabat
d'extrémité relié au panneau supérieur (14) com-
prenant deux rabats en chevauchement (22), l'un
des deux rabats en chevauchement (22) partant du
rabat intérieur de panneau supérieur (18) et l'autre
des deux rabats en chevauchement partant du
rabat extérieur de panneau supérieur (16), les
rabats en chevauchement étant collés l'un à l'autre
par un adhésif.

4. Support selon la revendication 1, dans lequel les
objets sont des boîtes de boisson (C) disposées en
deux couches, les boîtes de chaque couche étant
disposées en rangées parallèles aux panneaux
latéraux (12) et en rangées parallèles aux pan-
neaux d'extrémité (20), le nombre de boîtes des
rangées parallèles aux panneaux latéraux étant
supérieur de un ou plus au nombre de boîtes des
rangées parallèles aux panneaux d'extrémité.

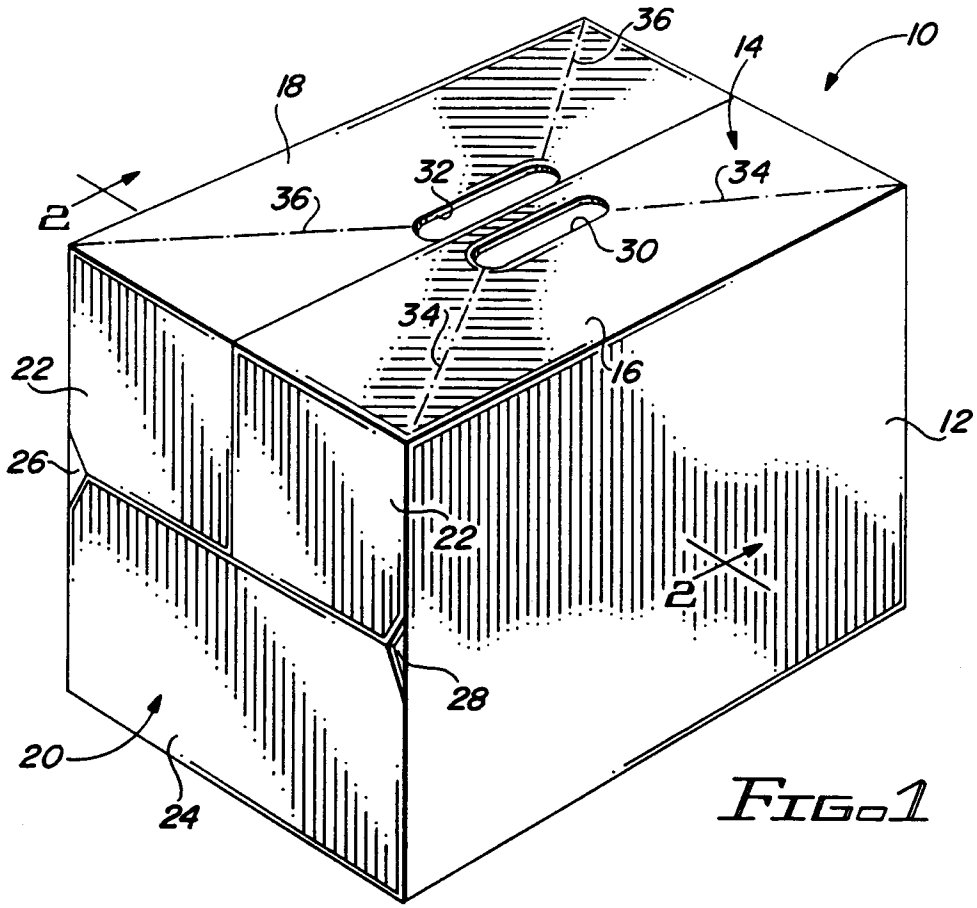

FIG. 1

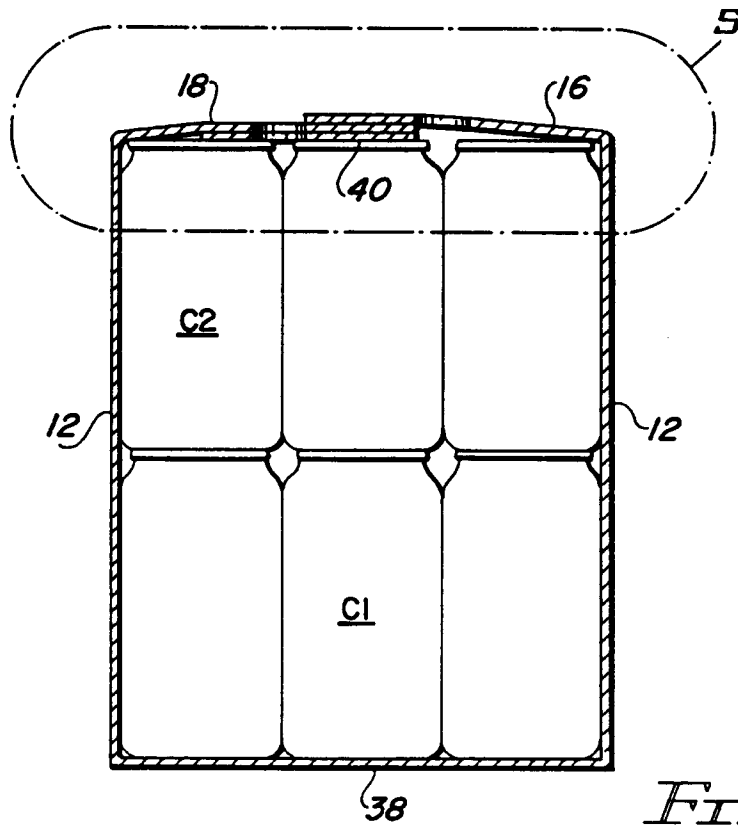

FIG. 2

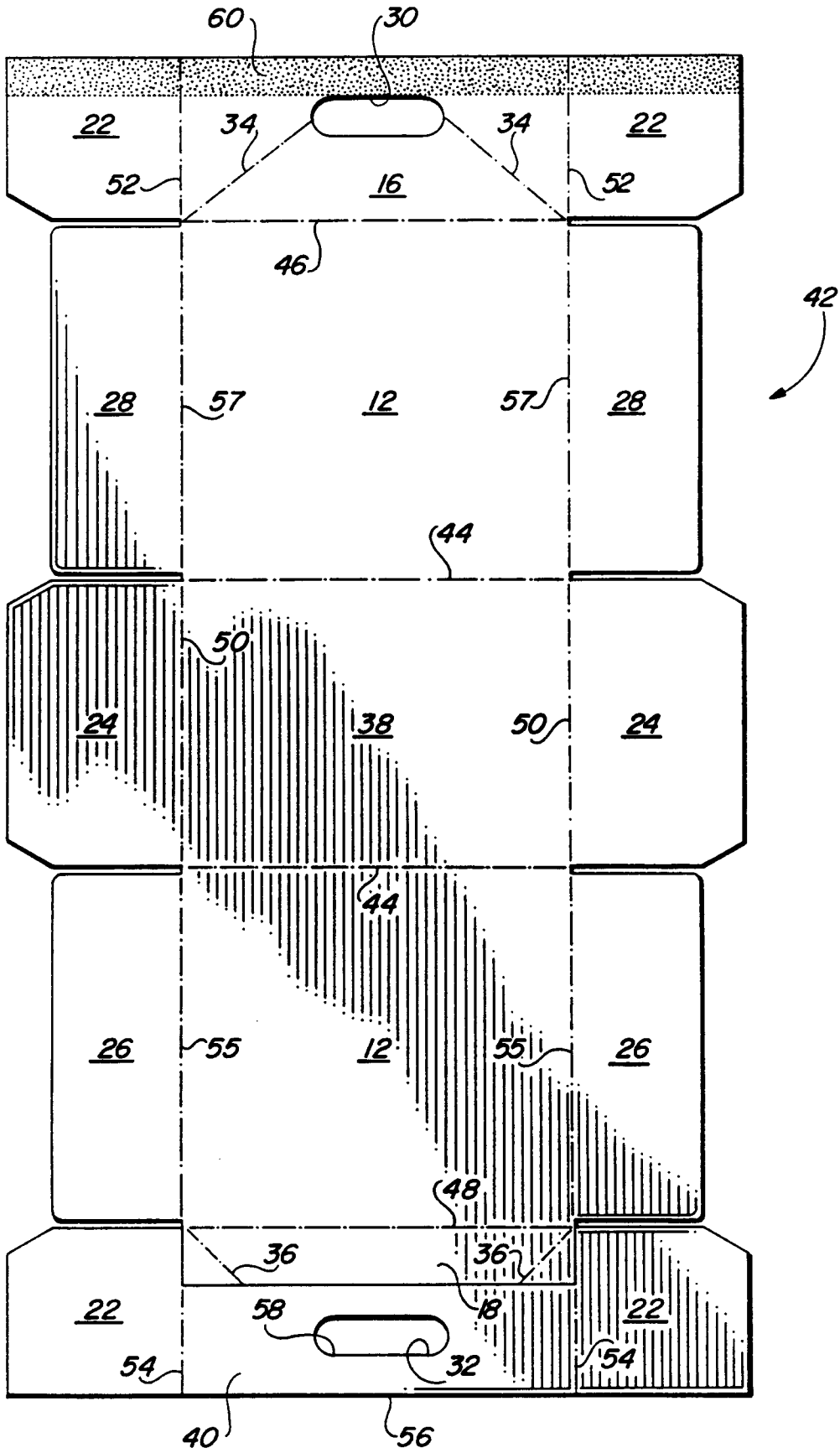

FIG. 4

