

[54] **ARRANGEMENT IN IMPACT PISTON MACHINES FOR DRILLING AND LIKE OPERATIONS, DRIVEN BY A TWO-STROKE INTERNAL COMBUSTION ENGINE**

1,191,948	7/1916	Coates.....	173/76
2,273,202	2/1942	Jackson.....	123/73 AD
1,951,858	3/1934	Bracke.....	123/56
2,480,879	9/1949	Rice, Jr.....	173/76

FOREIGN PATENTS OR APPLICATIONS

- [72] Inventor: **Bo Sven Bayard**, Taby, Sweden
- [73] Assignee: **Gustav Albert Bergman**, Taby, Sweden
- [22] Filed: **June 26, 1970**
- [21] Appl. No.: **50,161**

135,811	12/1929	Switzerland	173/76
943,755	3/1949	France.....	173/76

Primary Examiner—James A. Leppink
Attorney—Young & Thompson

- [30] **Foreign Application Priority Data**
 May 29, 1970 Sweden.....7457/70
- [52] **U.S. Cl.**.....173/116, 173/76, 173/122,
 123/73 A
- [51] **Int. Cl.**.....**B25d 9/10**
- [58] **Field of Search**173/76, 116, 139, 122; 123/56,
 123/73 A, 73 AD, 73 AE

[57] **ABSTRACT**

In impact piston machines for drilling and similar work driven by a two-stroke internal combustion engine it is conventional to combine the machine and the engine to a unit having a lubricating system common to all elements thereof. In order to avoid lubrication of the impact piston with oil burnt in the combustion engine cylinder, as in known machines, the crank housing of said engine is now located between the engine cylinder and impact piston cylinder, whereby lubricant which enters into the crank housing together with the combustion air can be distributed directly to the impact cylinder without having first to pass the internal combustion engine cylinder.

- [56] **References Cited**
- UNITED STATES PATENTS**
- 1,350,135 8/1920 Berg123/73 AE

3 Claims, 4 Drawing Figures

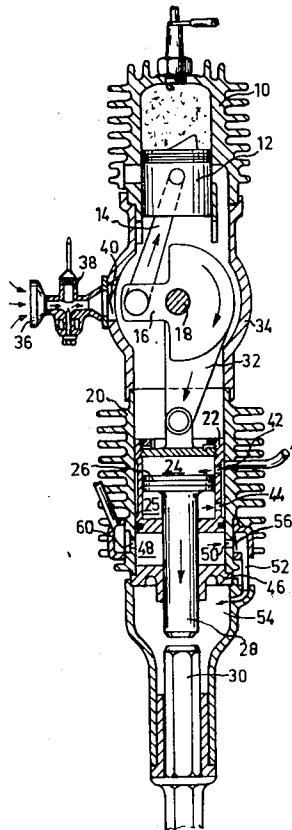

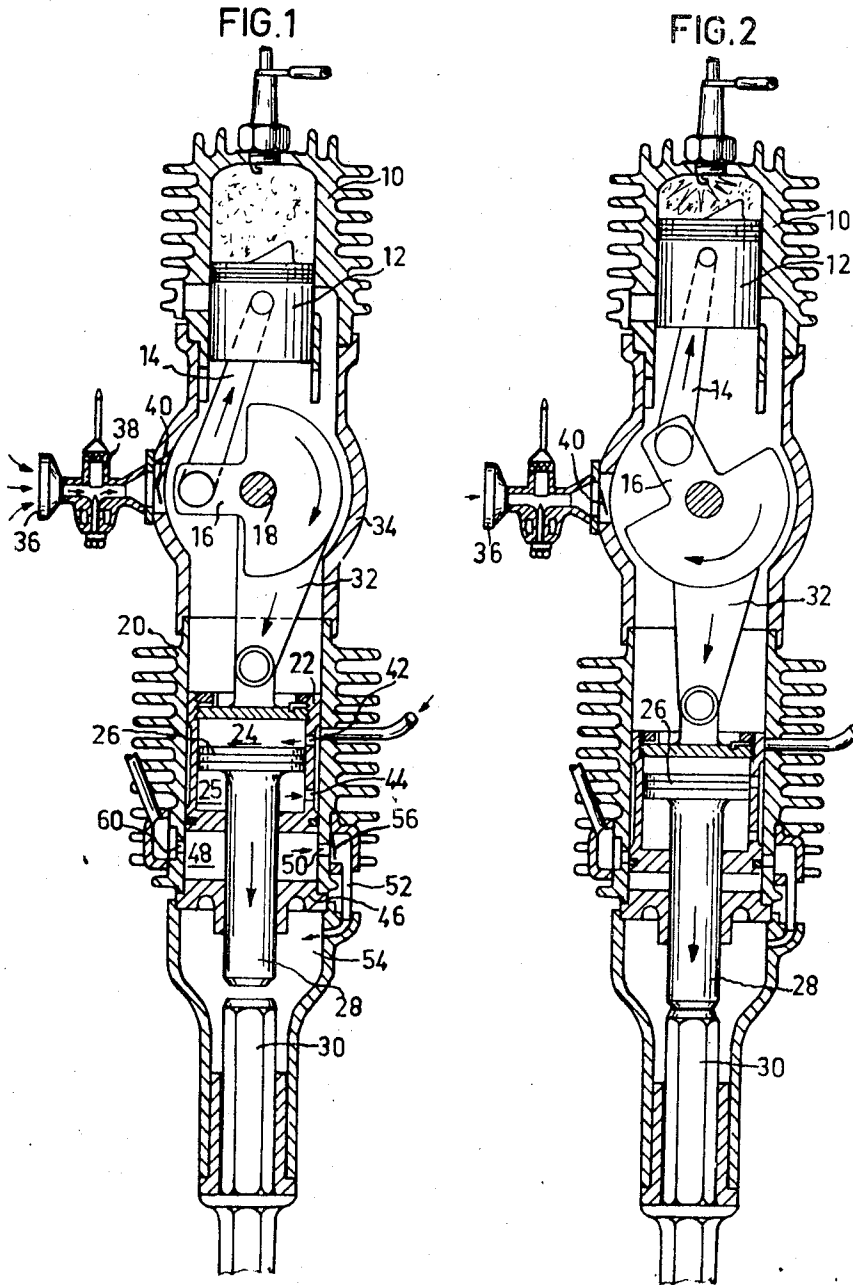

INVENTOR.
BO SVEN BAYARD
BY *Young + Thompson*
ATTYS.

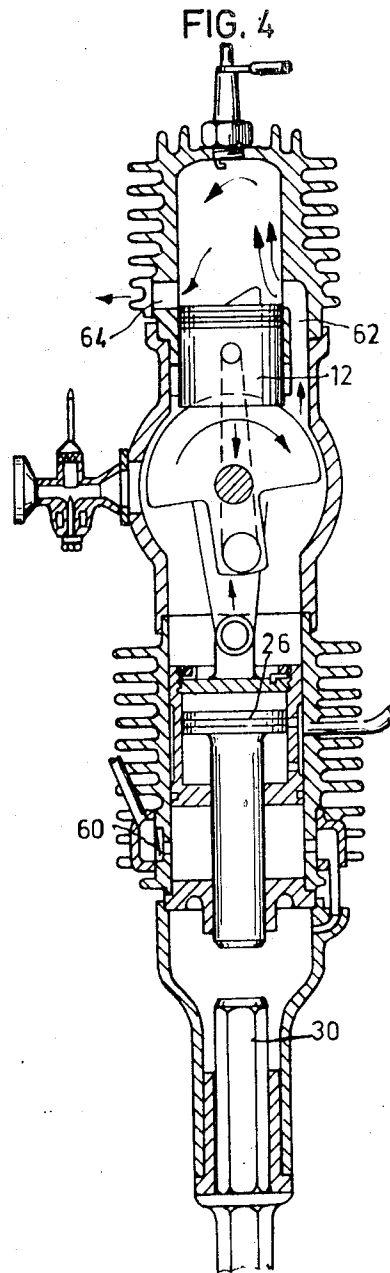
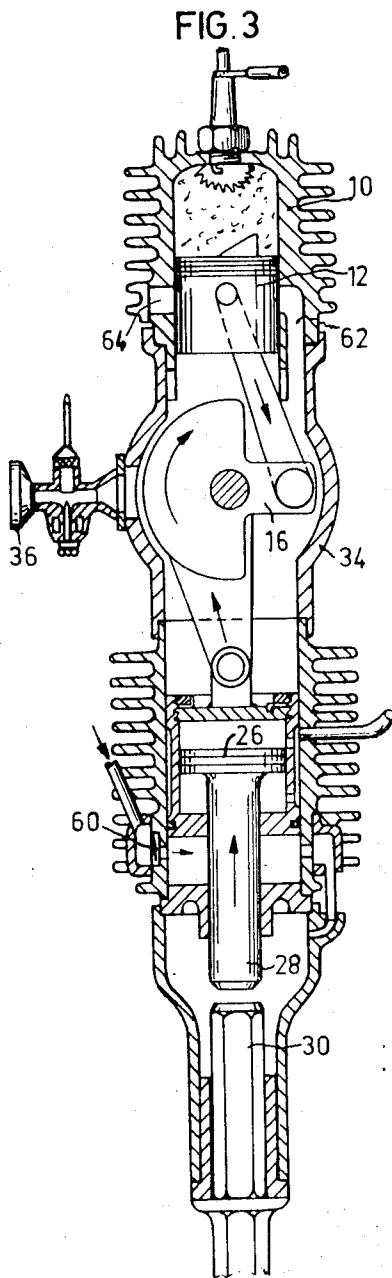

INVENTOR.
BO SVEN BAYARD
BY
Young + Thompson
ATTYS.

ARRANGEMENT IN IMPACT PISTON MACHINES FOR DRILLING AND LIKE OPERATIONS, DRIVEN BY A TWO-STROKE INTERNAL COMBUSTION ENGINE

It is normal practice in impact piston machines driven by internal combustion engines to arrange the impact piston cylinder as an extension of the engine cylinder, whereby the impact piston and the engine piston work towards each other in a manner whereby the impact piston is driven directly by the pressure of the combustion gases. The crank housing of the internal combustion engine is, in this case, situated above the engine cylinder and when using oil-fuel mixture, which is introduced into the crank housing for lubricating the engine and driving the same, the impact piston and impact piston cylinder are liable to be insufficiently lubricated, owing to the fact that a portion of the lubricant is burned in the engine cylinder and is thus not active in lubricating the impact piston.

The prime object of the present invention is to circumvent this disadvantage, said object being mainly achieved by means of an arrangement which is characterized in that the engine crank housing, which is provided with an inlet for oil-mixed fuel, is placed between the engine cylinder and the impact piston cylinder so that the impact piston cylinder, during normal use of the machine, is located beneath the crank housing and the engine cylinder over the same. By means of this arrangement the lubricant can be dispersed down from the crank housing directly into the impact piston cylinder without first having to pass the engine cylinder.

Further characteristics of the invention and advantages afforded thereby are evident from the following description of an embodiment illustrated in the accompanying drawing, in which FIGS. 1-4 illustrate a two-stroke internal combustion engine having a mechanical pneumatic impact means for forming a rock drilling machine or the like, showing the different stages of the combustion phase of the engine.

The drawing illustrates an engine cylinder 10, a piston 12 movable in said cylinder, a connecting rod 14, a crank 16 coaxing with said connecting rod and a crankshaft 18 on which the crank is formed. The mechanical pneumatic impact arrangement comprises an outer cylinder 20, an impact piston cylinder 22 movable therein and an impact piston 26 movable in said cylinder between gas cushions 24, 25, said impact piston 26 having a piston rod 28 for actuating the upper end of a tool 30. The impact piston cylinder 22 is actuated by the crank shaft 18 via a connecting rod 32. A crank housing 34 is mounted between the engine cylinder 10 and the outer cylinder 20.

A two-stroke internal combustion engine is normally lubricated in a manner whereby oil is mixed directly with the fuel during the suction-compression stroke. This is illustrated in FIG. 1, from which can be seen that air is sucked in through an air intake 36 and mixed with a gasoline-oil mixture entering through a nozzle 38 in the air suction passage. The air flows further through a crank housing valve 40 into the crank housing 34. Oil is deposited on all elements in the crank housing, such as bearings, cylinder walls etc. The density of the oil mist is determined by the quantity of oil in the gasoline. The oil mist lubricates the impact piston 26 through the reciprocating movement caused by the rotation of the crank shaft by means of the connecting rod 32 and the impact piston cylinder 22, air mixed with the oil mist alternately pulsating through openings 42, 44 in the walls of the impact piston cylinder on either sides of the impact piston in the center position thereof. Air flows

from one air cushion 25 to the other 24, as shown by arrows beneath and above the impact piston of FIG. 1. Arranged beneath the impact piston cylinder, between said cylinder and a lower end wall 46, is a compressor chamber 48 which communicates through an opening 50 and a channel 52 with a chamber 54 containing the lower end of the impact piston rod 28 and the upper end of the tool 30. The opening 50 is provided with a nonreturn valve 56, which opens to permit flow through the opening and to the passage 52 but closes to prevent flow in the opposite direction. When the impact piston cylinder 22, which acts as a compressor piston in the chamber 48, moves downwards, the compressed air laden with oil is conveyed through the valve 56 to the chamber 55 for lubricating possible rotating mechanisms and the tool.

The fuel air mixture is compressed on the upper side of the engine piston 12 in the engine cylinder at the stage illustrated in FIG. 1. FIG. 2 illustrates the ignition of the compressed gaseous mixture and the final stage of the suction stroke. FIG. 2 also illustrates the dispersion of the fuel oil mist in the crank housing and cylinder portions. FIG. 3 illustrates how the combustion of the fuel air mixture and the gases generated thereby drives the engine piston and how the fuel air mixture is precompressed in the crank housing. The compressor portion sucks in injection air through a suction valve 60. FIG. 4 illustrates the passage of the fuel oil air mixture through the upper flow passage 62 of the engine, from the crank housing to the engine cylinder, and how the gaseous mixture flushes the cylinder from combusted gases, which depart through the outlet passage 64 of the engine.

The impact means need not necessarily be designed as illustrated in the drawing, the essential thing being that the impact means and the engine portion have a common crank housing and that the oil which lubricates the engine portion also lubricates the impact compressor and drill rotating means and the tool shank and that the lubricating oil is fresh and not as in the case with other known internal combustion engine driven drilling machines using automatic lubrication by mixing oil in the fuel and in which the impact and rotating portion are lubricated with the surplus oil remaining subsequent to the combustion sequence in the engine portion.

What I claim is:

1. In an impact piston machine for drilling, chiseling and the like, comprising a two-stroke internal combustion engine having a cylinder and a piston reciprocable in the cylinder and an impact piston cylinder and an impact piston reciprocable in the impact piston cylinder in line with said engine piston; the improvement comprising a crankshaft common to and disposed between both said pistons, connecting rods interconnecting said crankshaft with said pistons, a crankcase surrounding said crankshaft and connected at one end to said engine cylinder and the other end to said impact piston cylinder, and means extending through a sidewall of said crankcase for introducing an oil-fuel mixture directly into said crankcase whereby said oil-fuel mixture lubricates said crankshaft and both said pistons without having first to pass the internal combustion engine cylinder.

2. An impact piston machine as claimed in claim 1, and a pneumatic device interposed between said impact piston and the associated said connecting rod.

3. An impact piston machine as claimed in claim 2, said pneumatic device comprising a cylinder closed at both ends and containing a portion of said impact piston and being slidable in said impact piston cylinder.

* * * * *