



(19) **United States**

(12) **Patent Application Publication**

**Newman, JR. et al.**

(10) **Pub. No.: US 2021/0211063 A1**

(43) **Pub. Date: Jul. 8, 2021**

(54) **LOAD CONTROL DEVICE FOR HIGH-EFFICIENCY LOADS**

(71) Applicant: **Lutron Technology Company LLC**, Coopersburg, PA (US)

(72) Inventors: **Robert C Newman, JR.**, Emmaus, PA (US); **Daniel F. Carmen**, Schnecksville, PA (US); **Christopher J. Salvestrini**, Allentown, PA (US); **Matthew V. Harte**, Emmaus, PA (US)

(73) Assignee: **Lutron Technology Company LLC**, Coopersburg, PA (US)

(21) Appl. No.: **17/208,753**

(22) Filed: **Mar. 22, 2021**

**Related U.S. Application Data**

(63) Continuation of application No. 16/713,377, filed on Dec. 13, 2019, now Pat. No. 10,958,187, which is a continuation of application No. 16/186,804, filed on Nov. 12, 2018, now Pat. No. 10,530,268, which is a continuation of application No. 15/947,216, filed on Apr. 6, 2018, now Pat. No. 10,128,772, which is a continuation of application No. 15/131,444, filed on Apr. 18, 2016, now Pat. No. 9,941,811, which is a continuation of application No. 14/844,252, filed on Sep. 3, 2015, now Pat. No. 9,356,531, which is a continuation-in-part of application No. 14/153,558, filed on Jan. 13, 2014, now Pat. No. 9,160,224, which is a continuation-in-part of application No. 13/775,702, filed on Feb. 25, 2013, now Pat. No. 8,988,050, which is a continuation-in-part of application No. 13/458,324, filed on Apr. 27, 2012, now Pat. No. 8,957,662, which is a continuation-in-part of application No. 13/232,344, filed on Sep. 14, 2011, now Pat. No. 8,698,408, which is a continuation of application No. 12/952,920, filed on Nov. 23, 2010, now Pat. No. 8,664,881.

(60) Provisional application No. 61/333,050, filed on May 10, 2010, provisional application No. 61/264,528, filed on Nov. 25, 2009.

**Publication Classification**

- (51) **Int. Cl.**
- H02M 7/06* (2006.01)
  - H05B 39/04* (2006.01)
  - H02M 1/32* (2006.01)
  - H05B 45/10* (2006.01)
  - H05B 45/37* (2006.01)
  - H02M 1/08* (2006.01)
  - H02M 5/257* (2006.01)
  - H02M 5/293* (2006.01)
  - H02M 1/088* (2006.01)
- (52) **U.S. Cl.**
- CPC ..... *H02M 7/06* (2013.01); *H05B 39/044* (2013.01); *H05B 39/048* (2013.01); *H02M 1/32* (2013.01); *H05B 45/10* (2020.01); *H02M 2001/0006* (2013.01); *H05B 39/04* (2013.01); *H02M 1/081* (2013.01); *H02M 5/2573* (2013.01); *H02M 5/293* (2013.01); *H02M 1/088* (2013.01); *H05B 45/37* (2020.01)

(57) **ABSTRACT**

A load control device for controlling the power delivered from an AC power source to an electrical load includes a thyristor, a gate coupling circuit for conducting a gate current through a gate of the thyristor, and a control circuit for controlling the gate coupling circuit to conduct the gate current through a first current path to render the thyristor conductive at a firing time during a half cycle. The gate coupling circuit is able to conduct the gate current through the first current path again after the firing time, but the gate current is not able to be conducted through the gate from a transition time before the end of the half-cycle until approximately the end of the half-cycle. The load current is able to be conducted through a second current path to the electrical load after the transition time until approximately the end of the half-cycle.

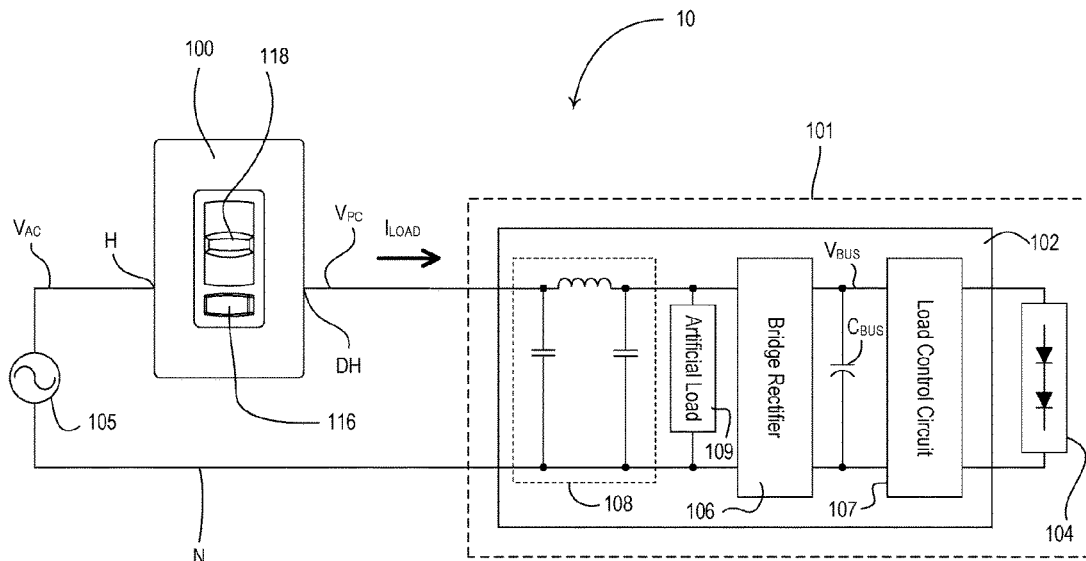

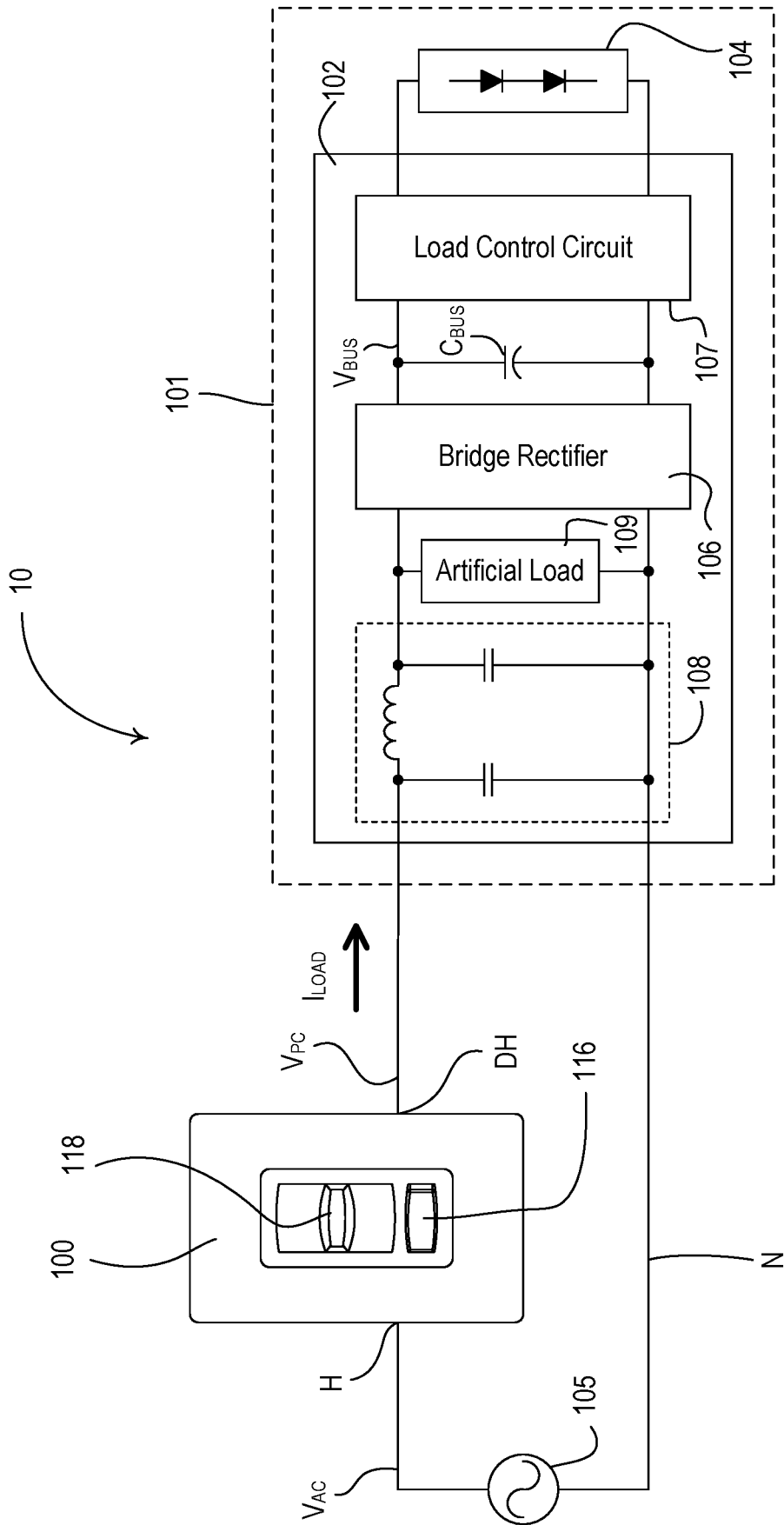

Fig. 1

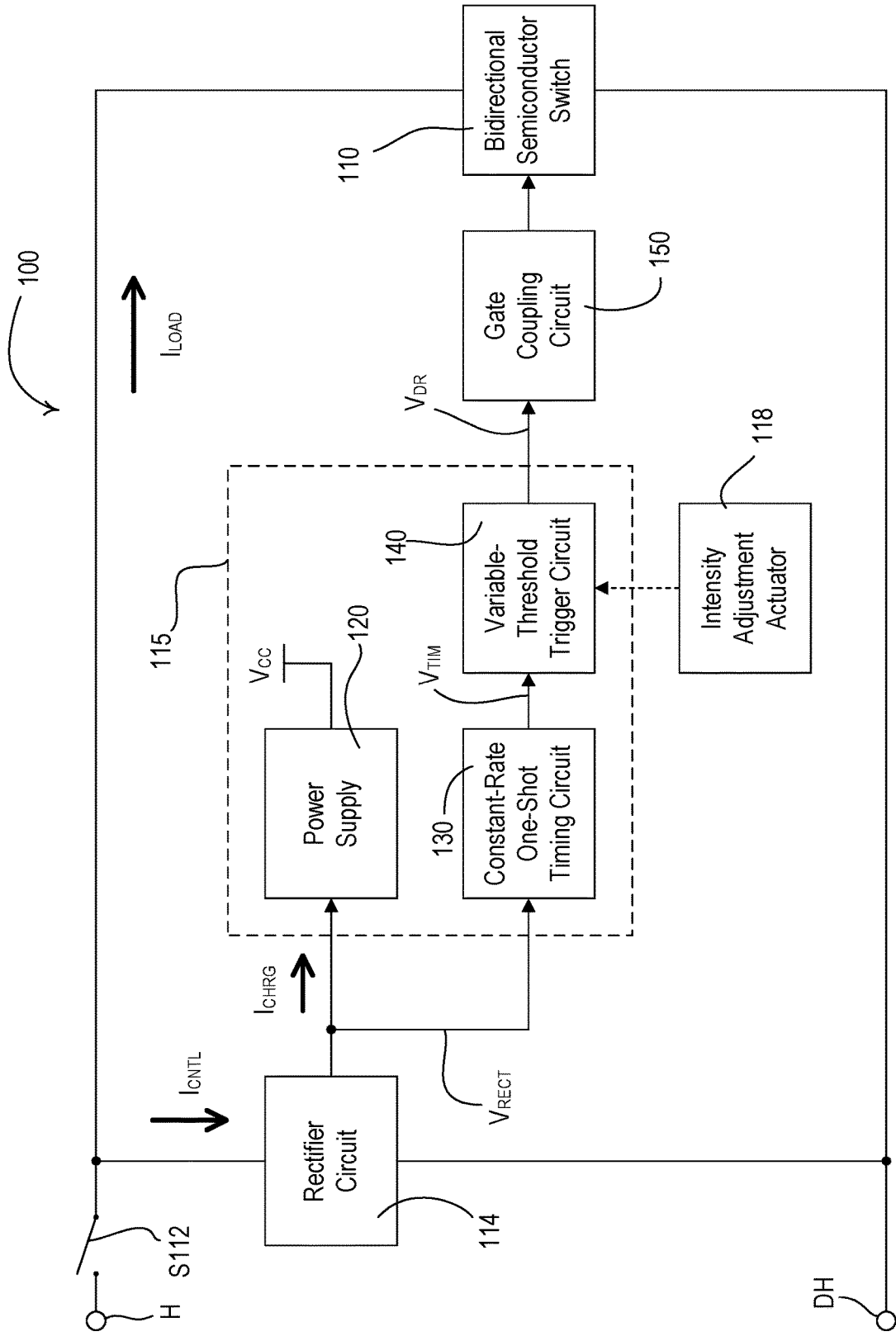

Fig. 2

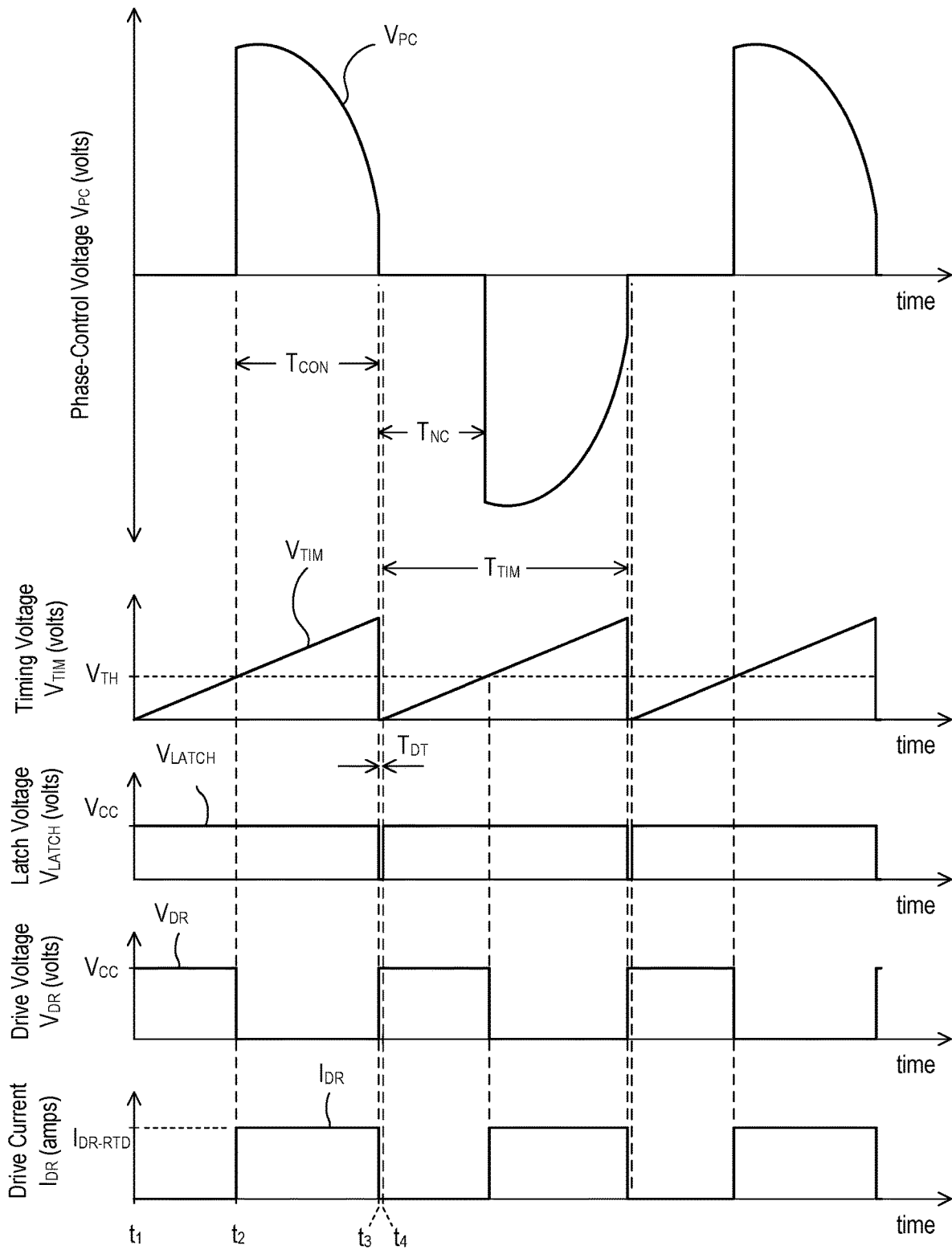

Fig. 3A

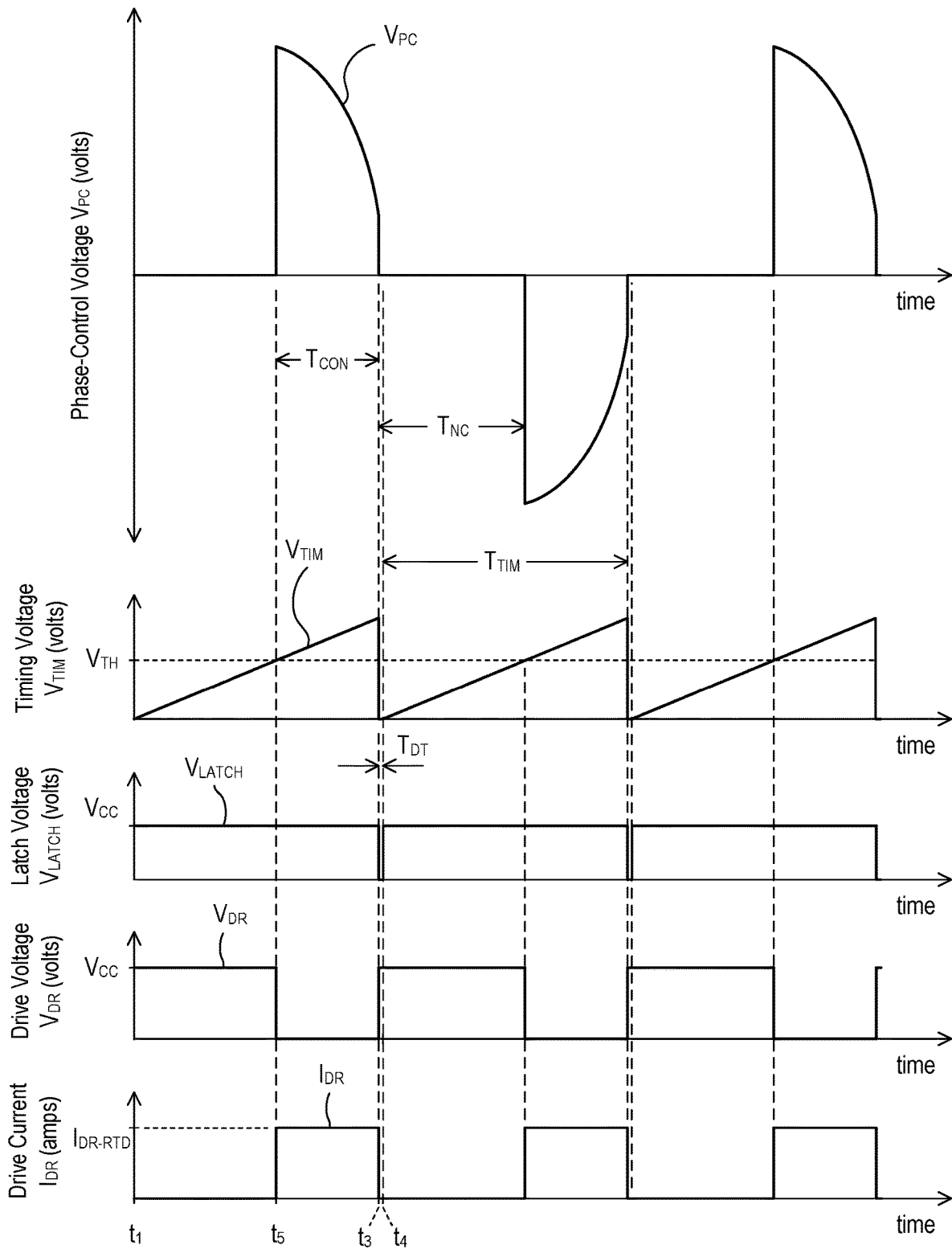

Fig. 3B

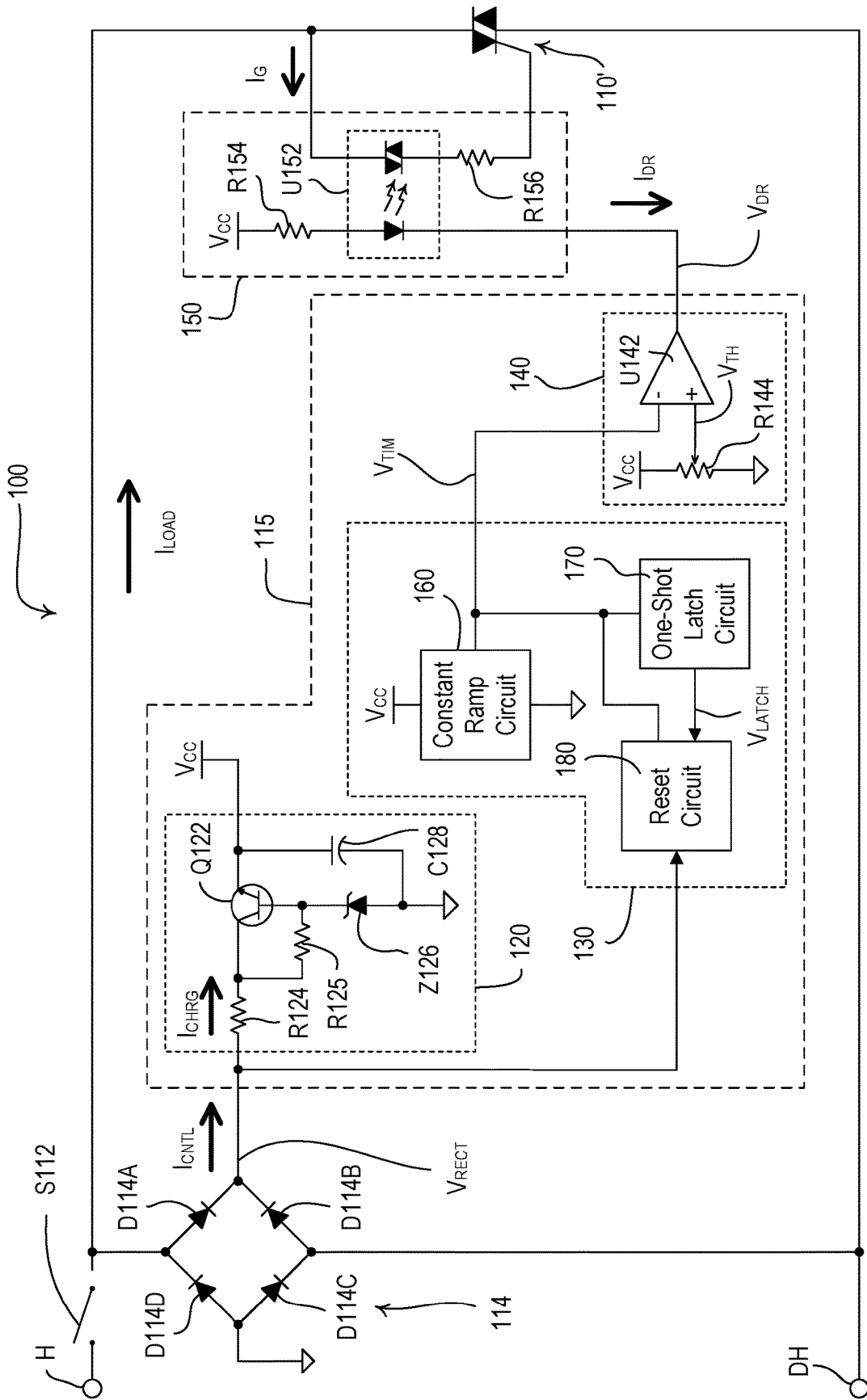

Fig. 4

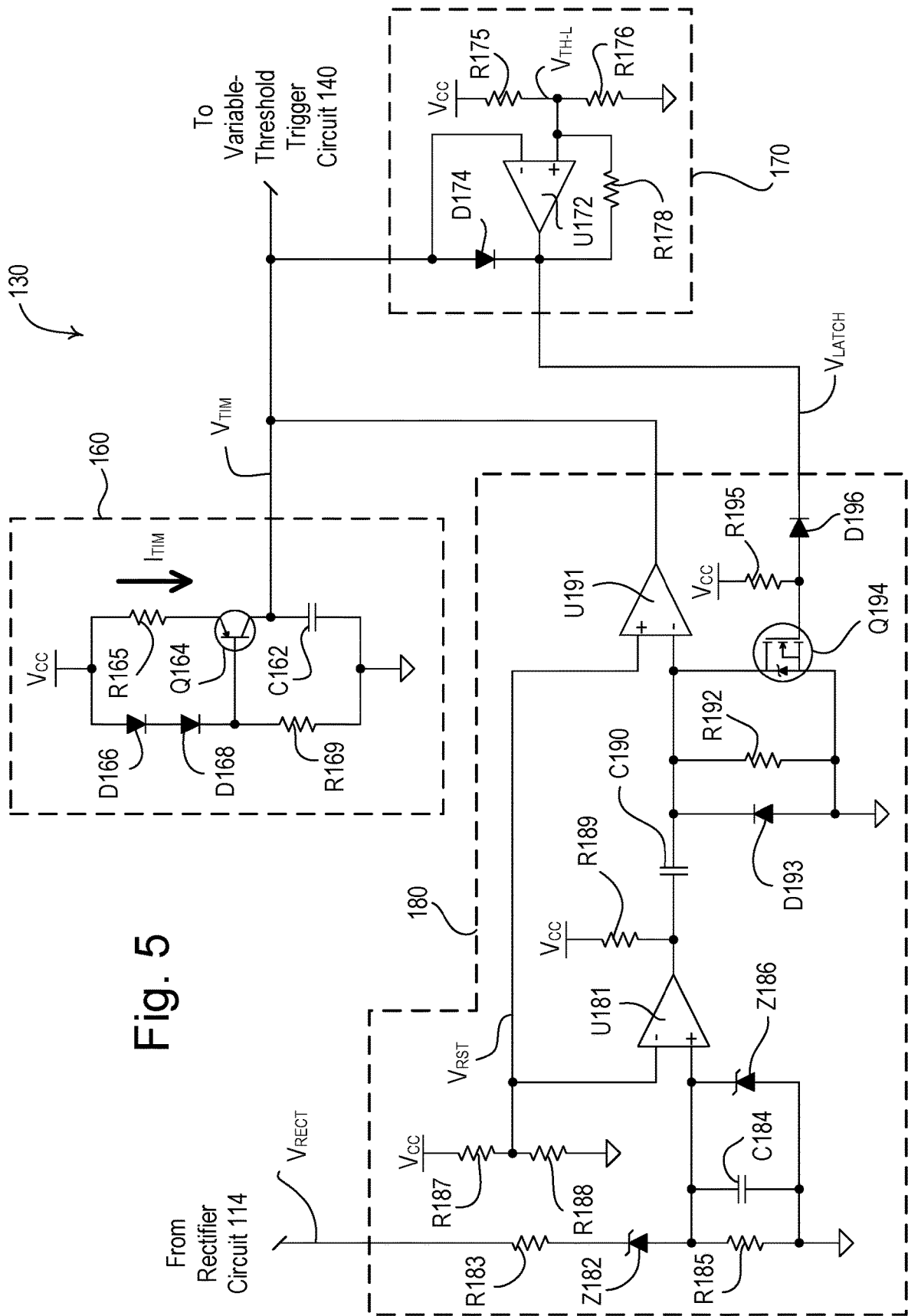

Fig. 5

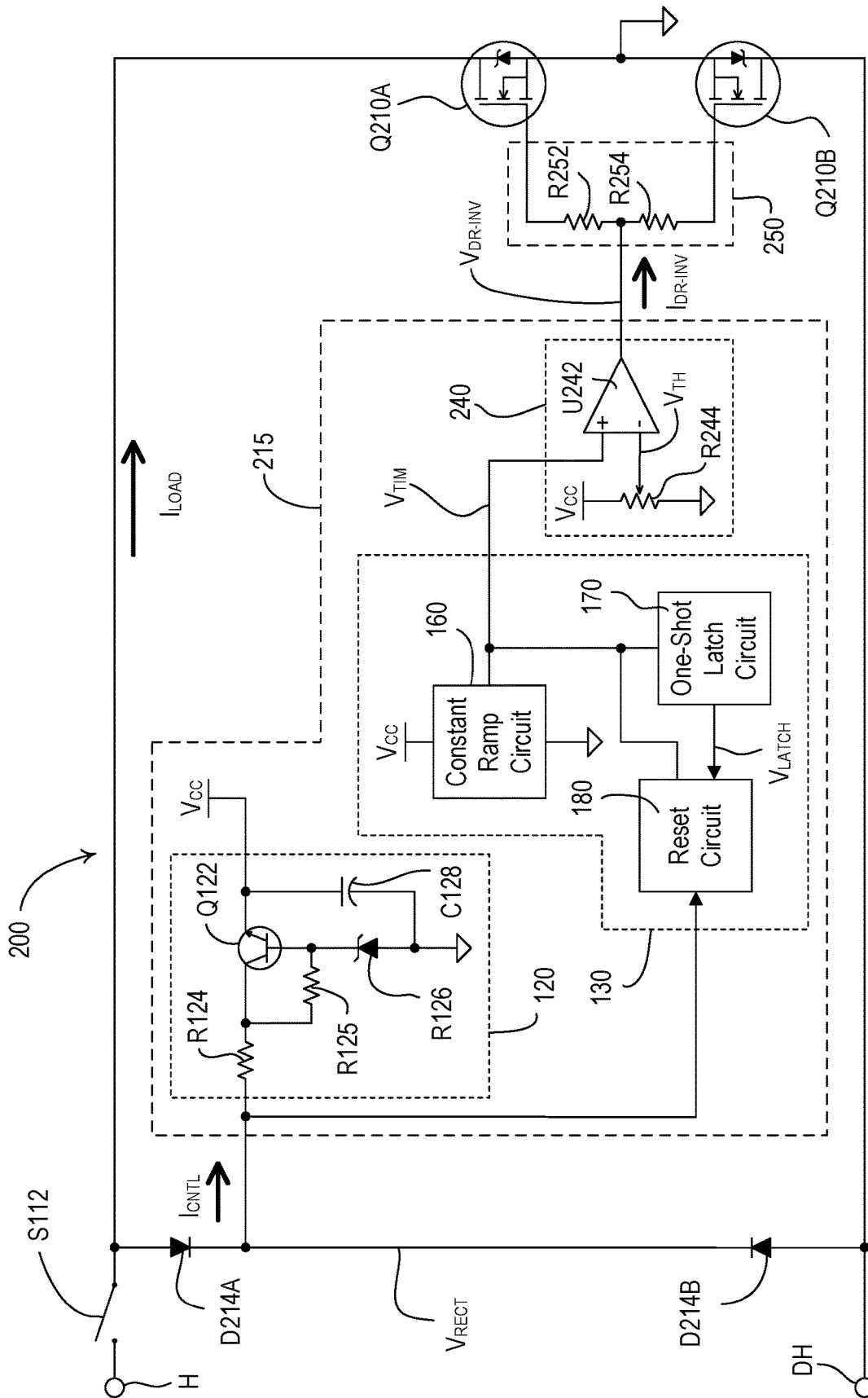

Fig. 6



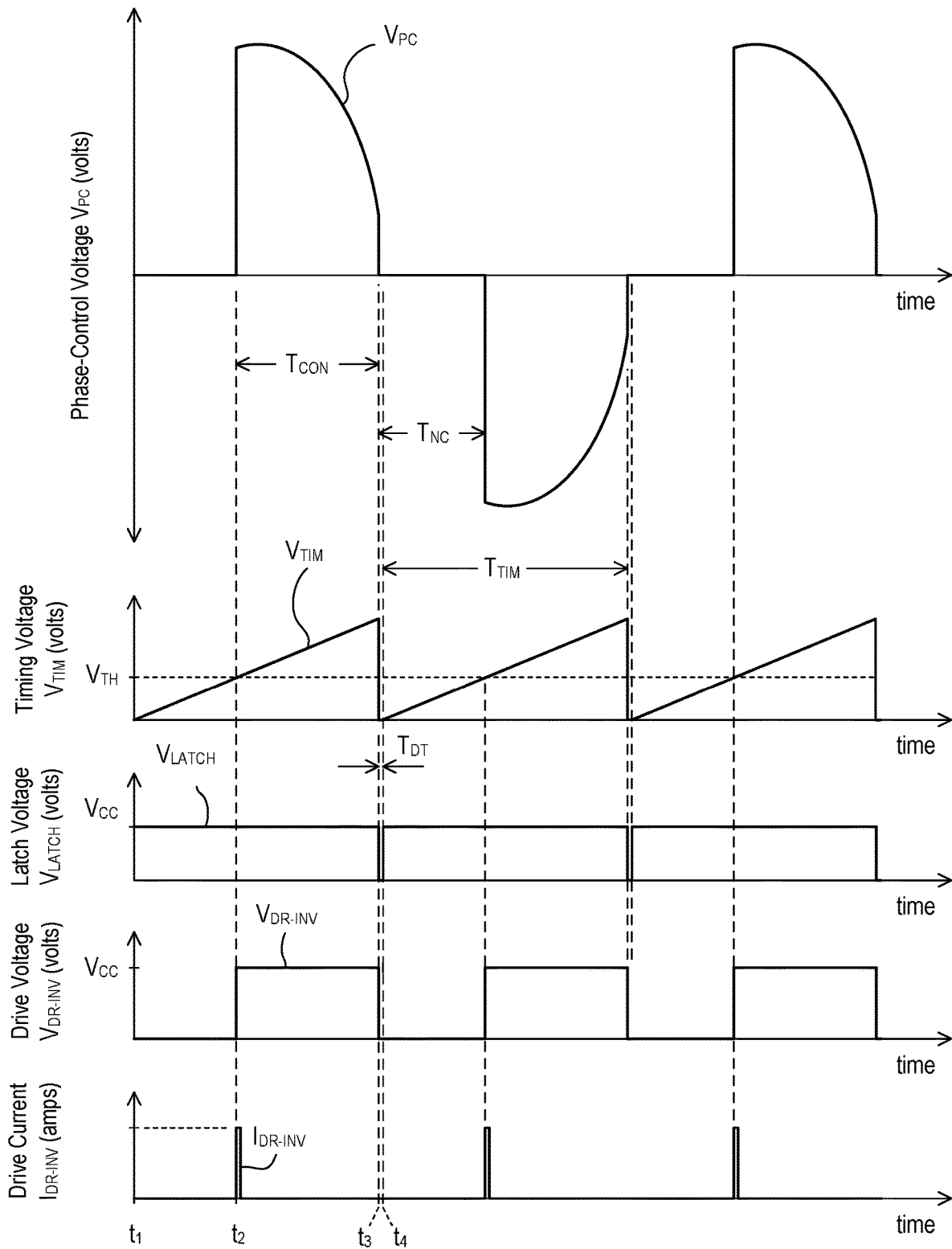

Fig. 7

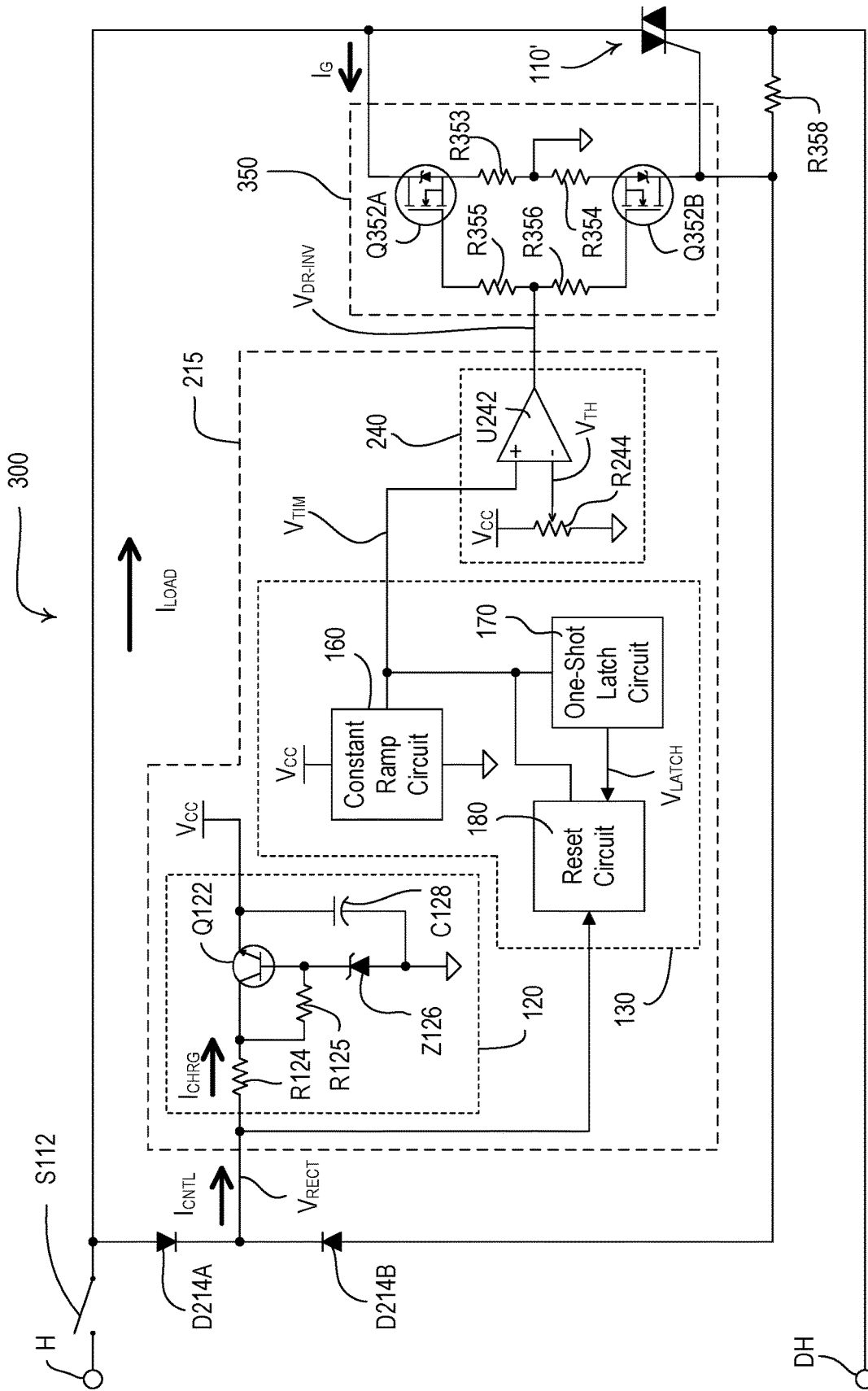

Fig. 8

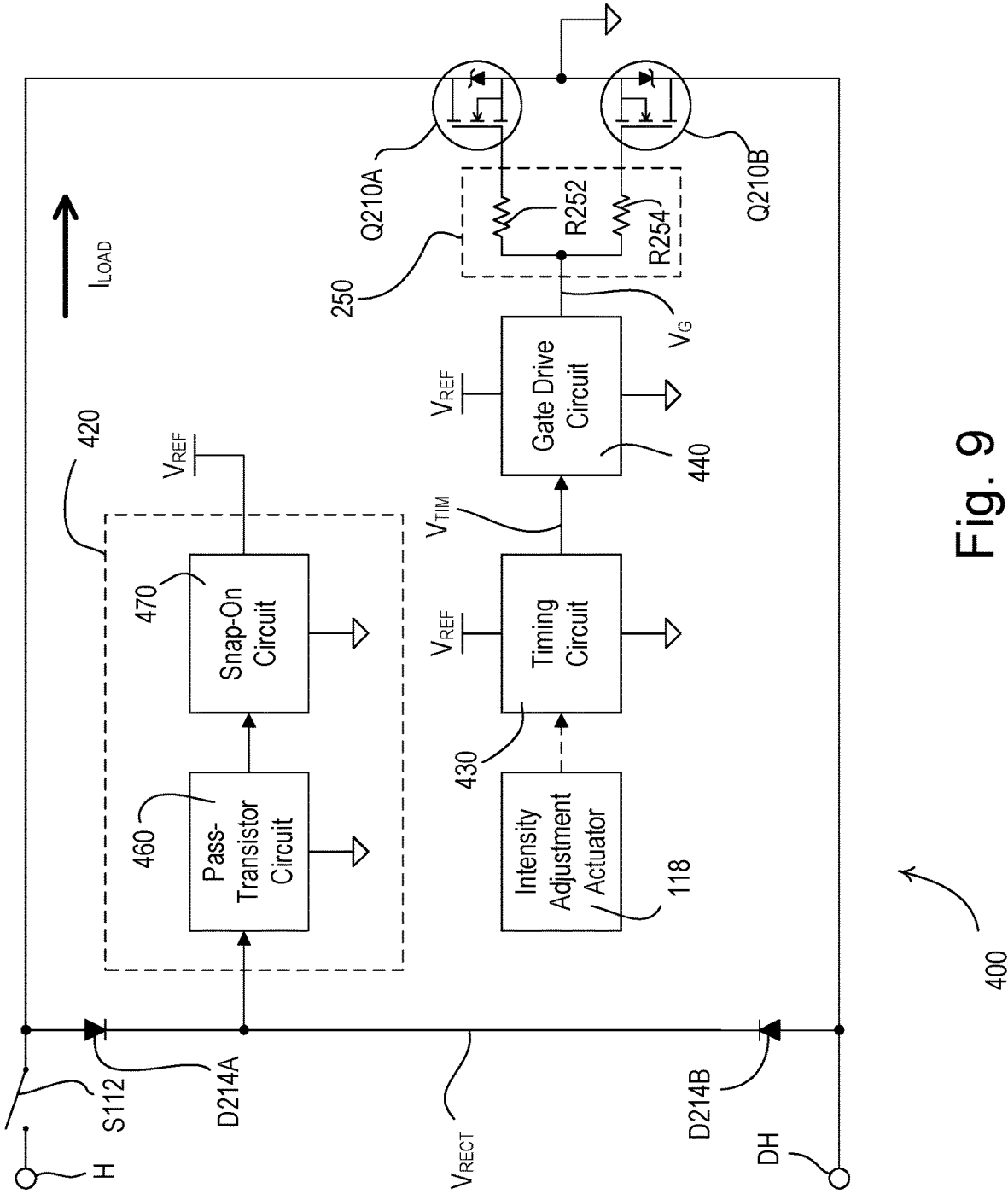

Fig. 9

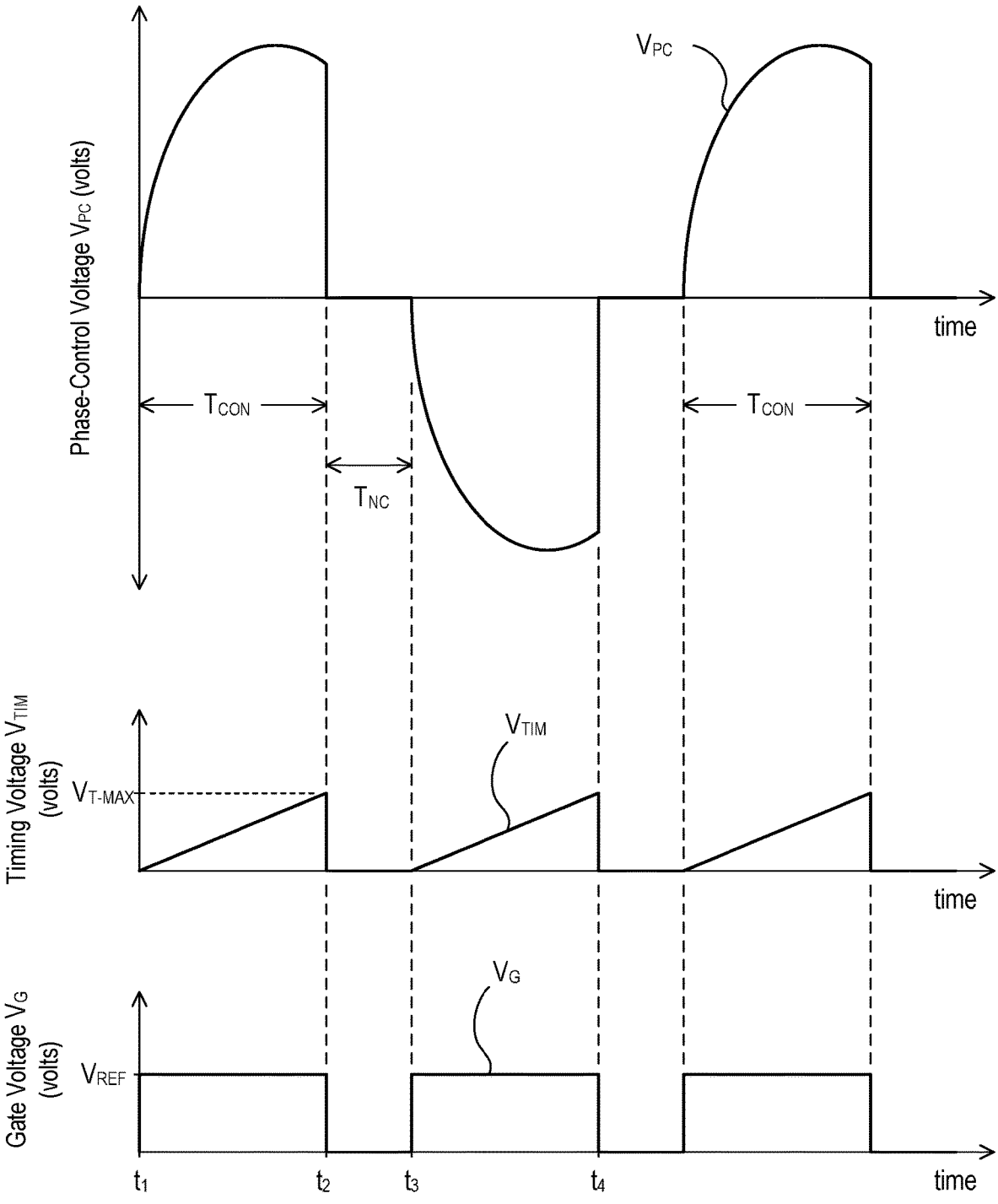

Fig. 10

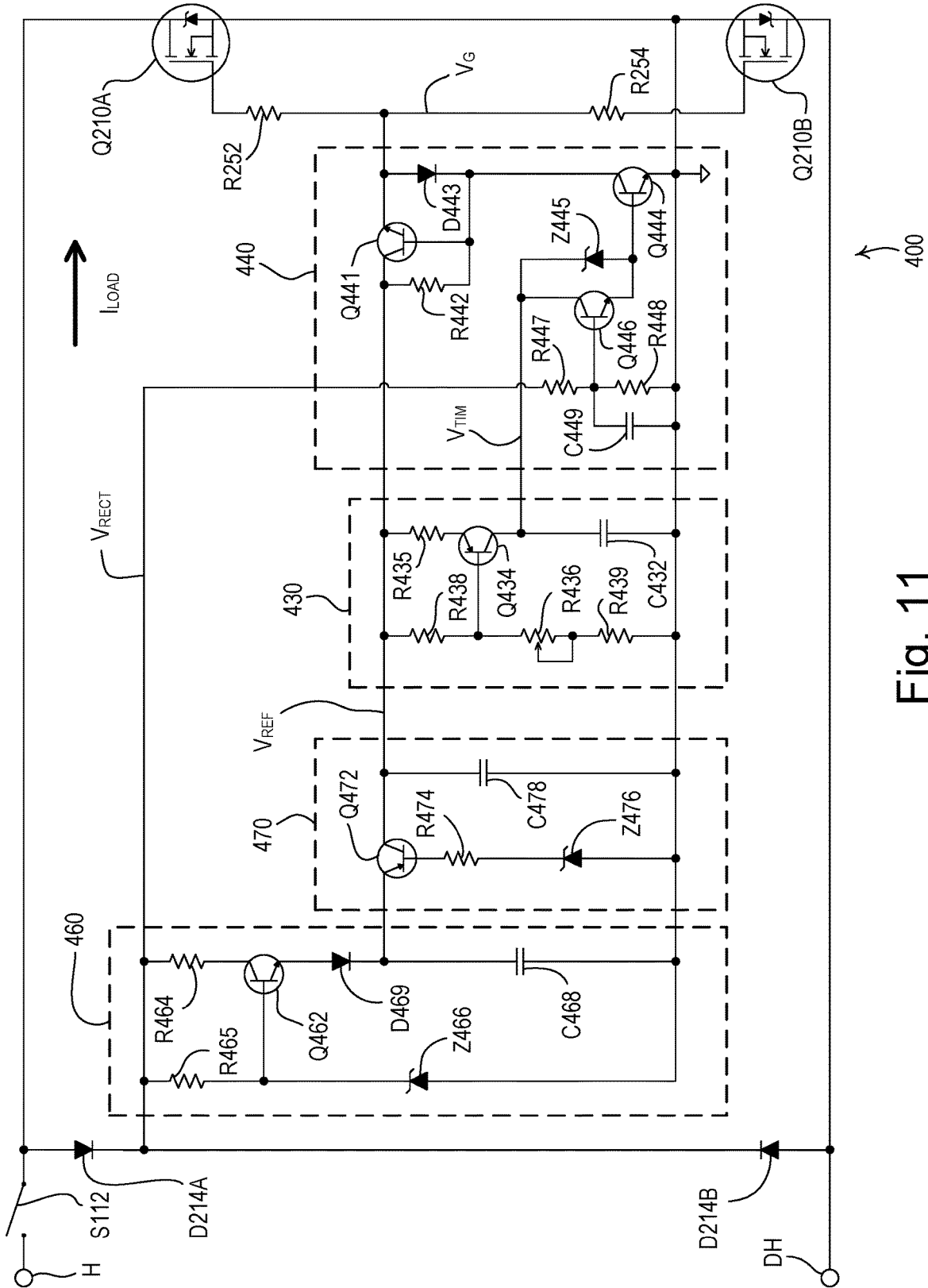

Fig. 11

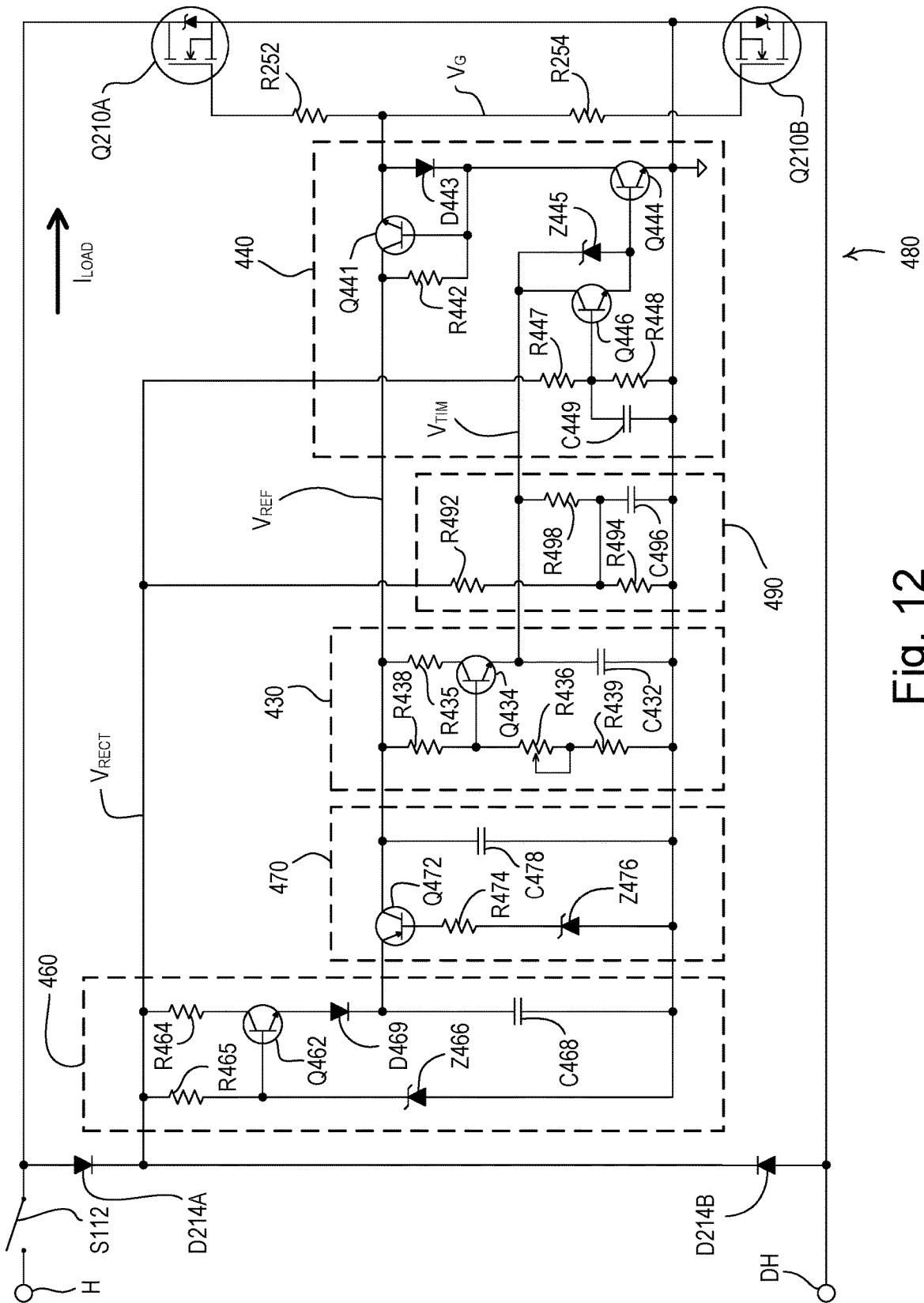

Fig. 12

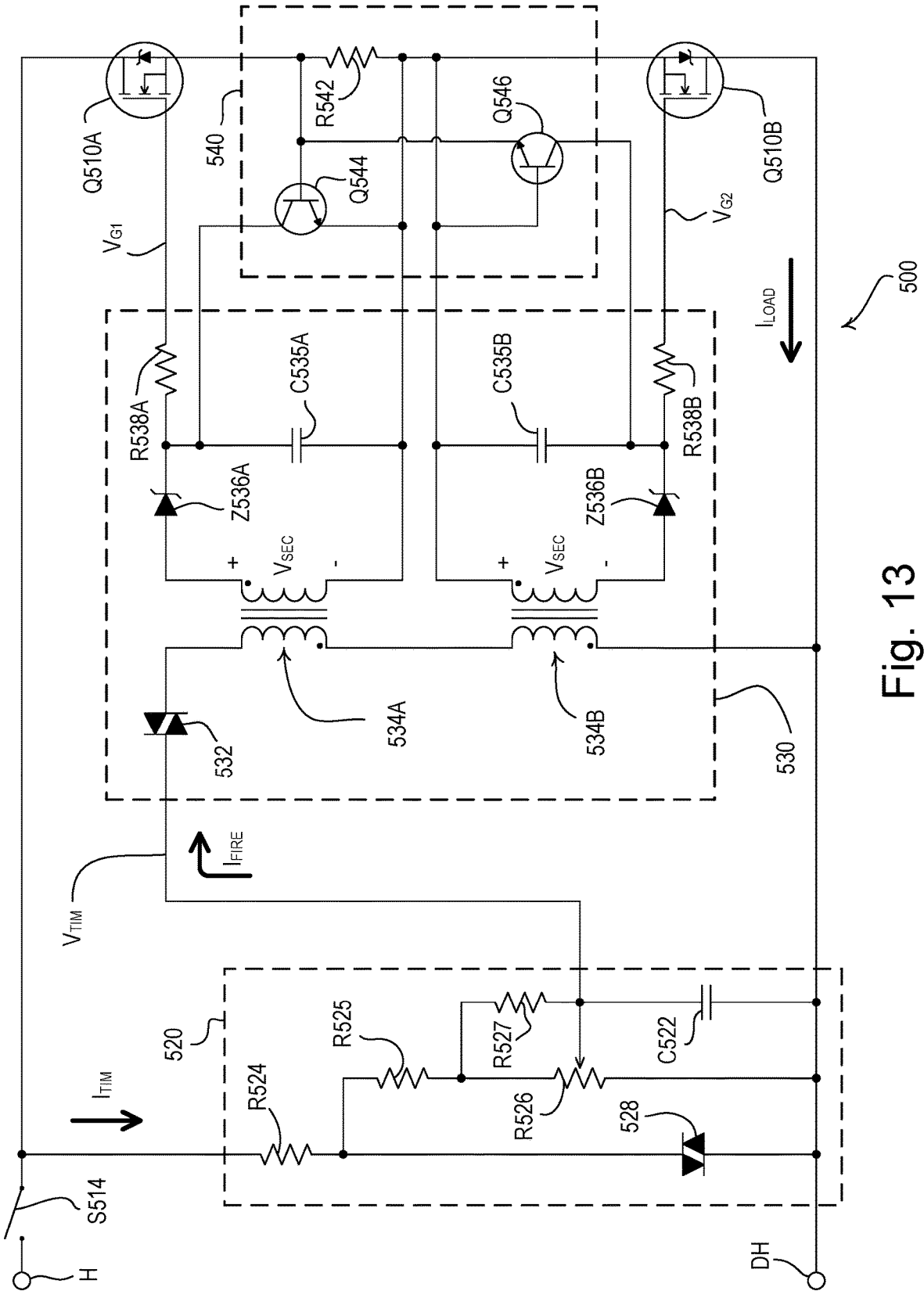

Fig. 13

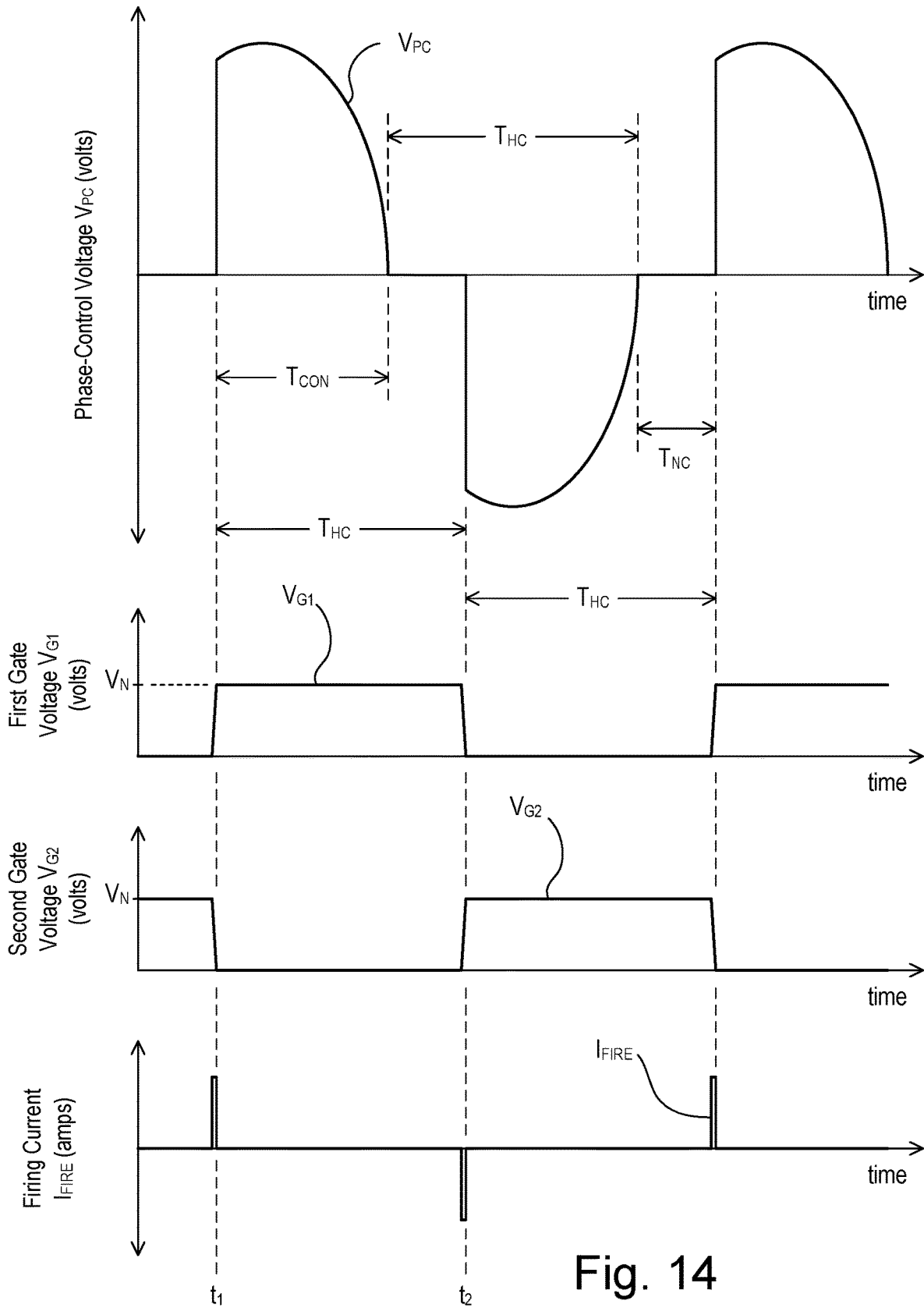

Fig. 14



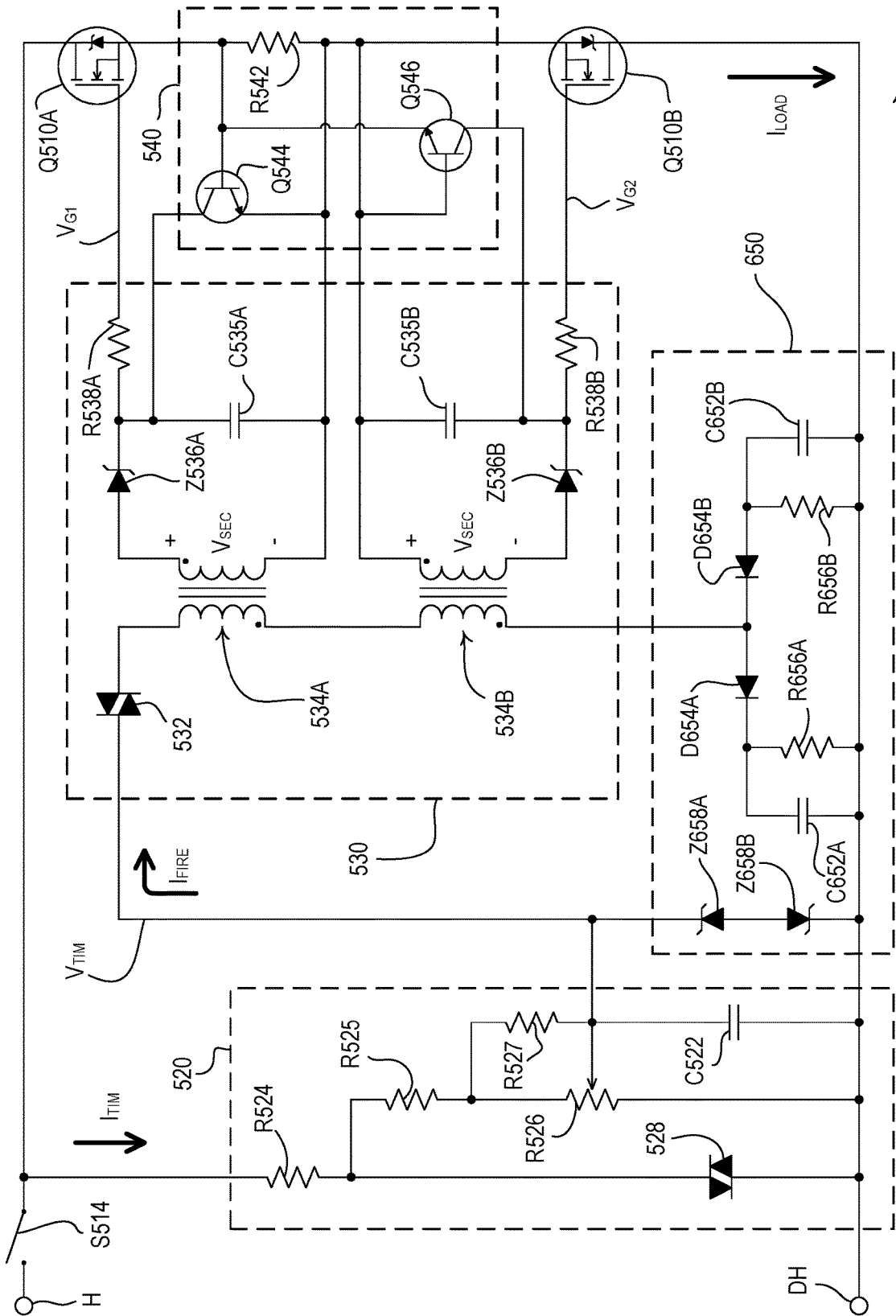

Fig. 15 600

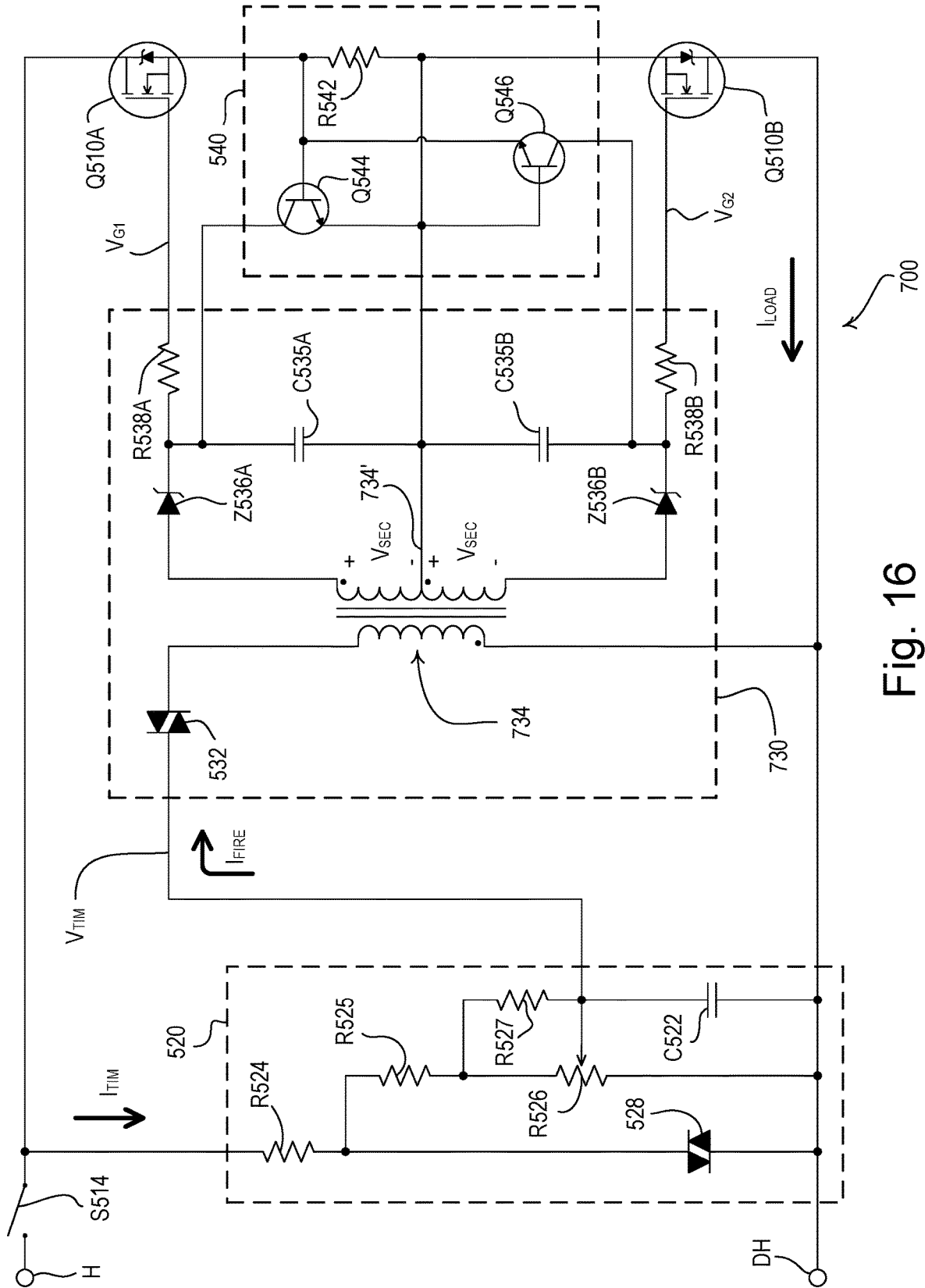

Fig. 16

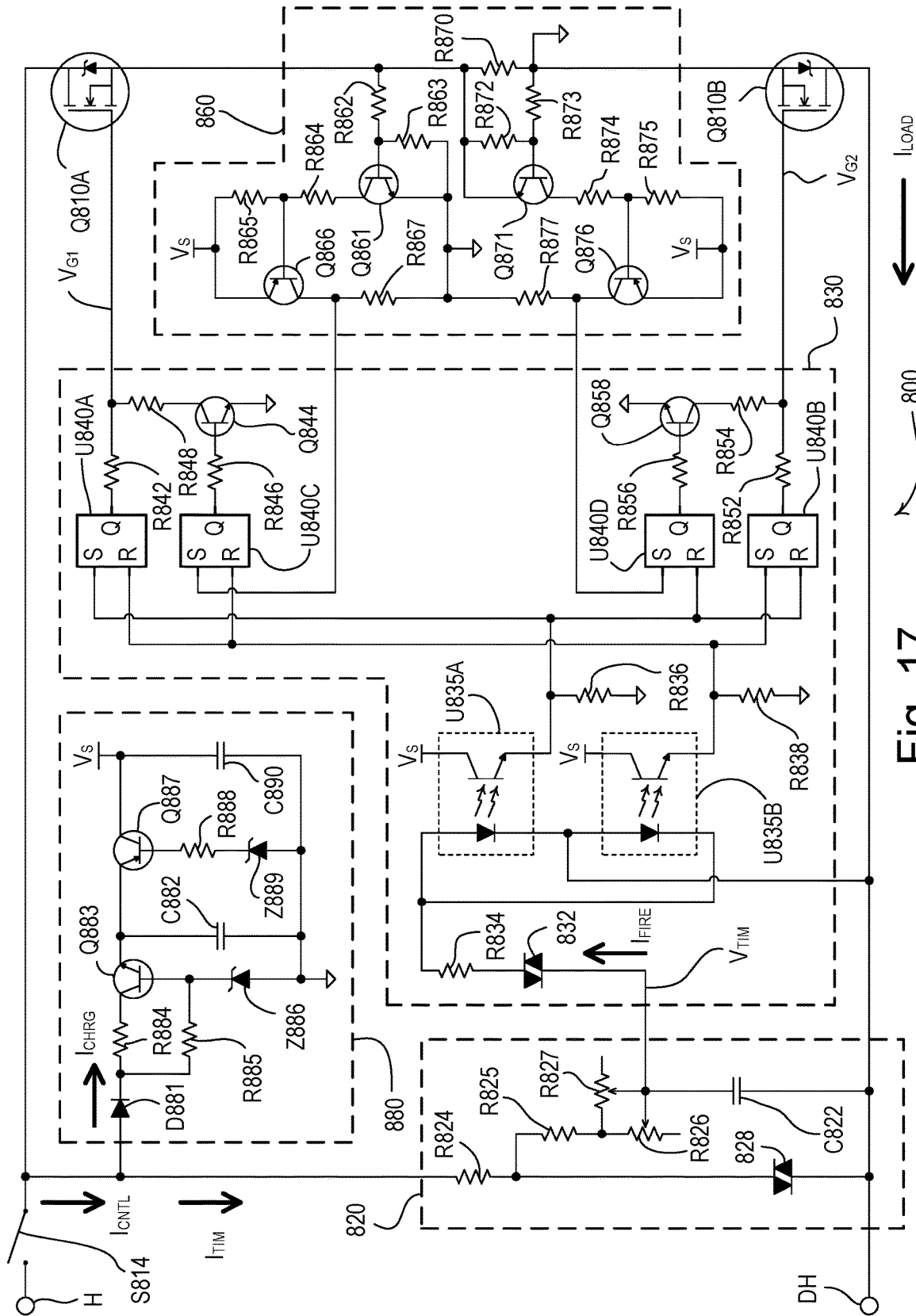

Fig. 17

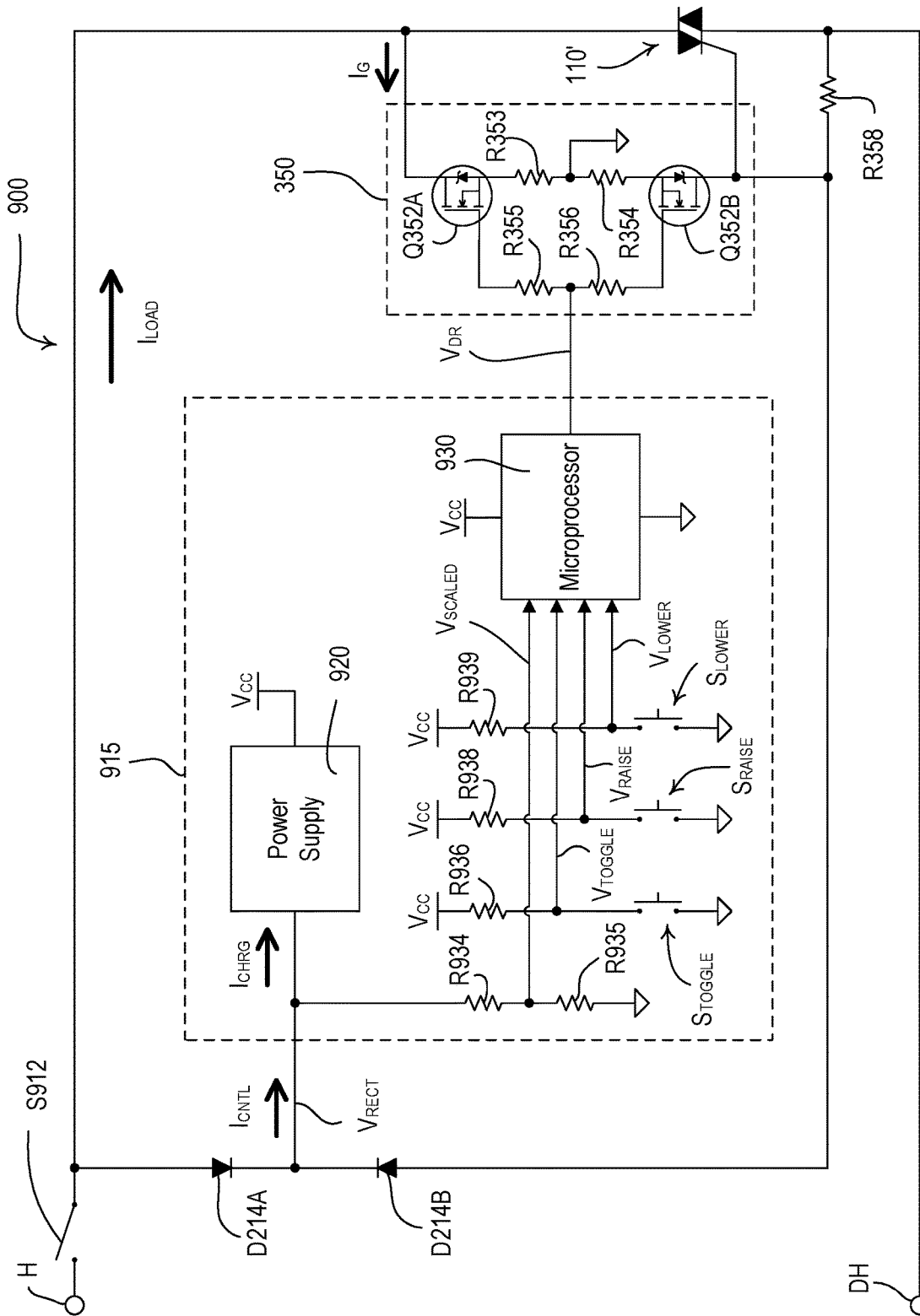

Fig. 18

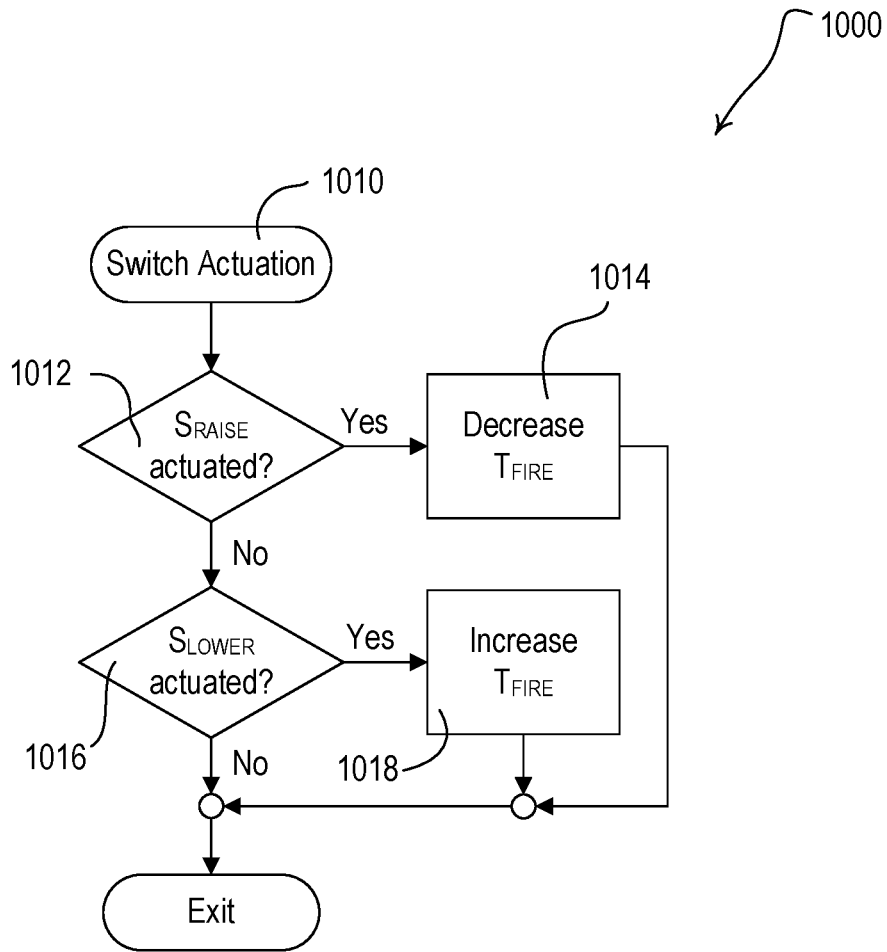

Fig. 19

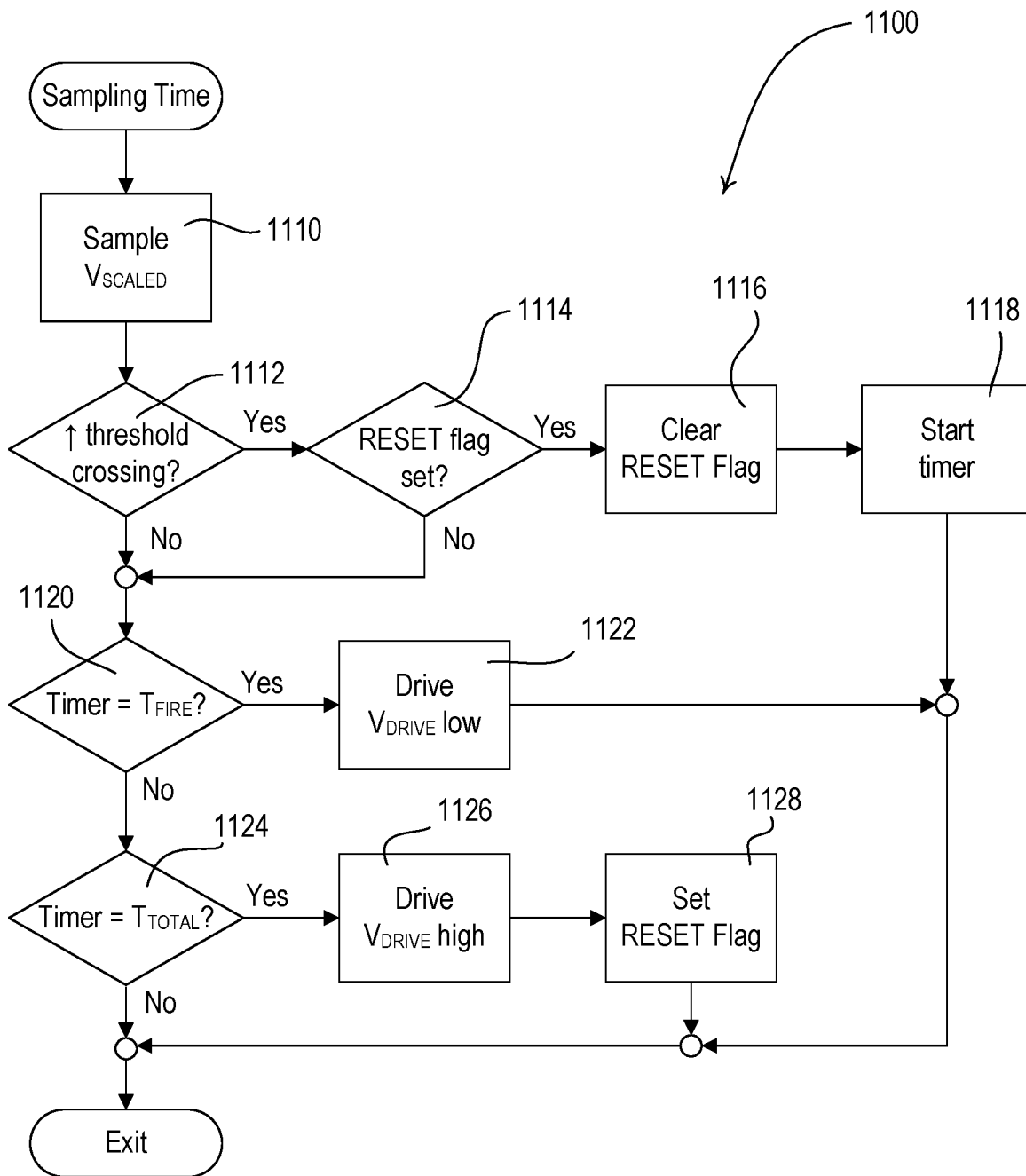

Fig. 20

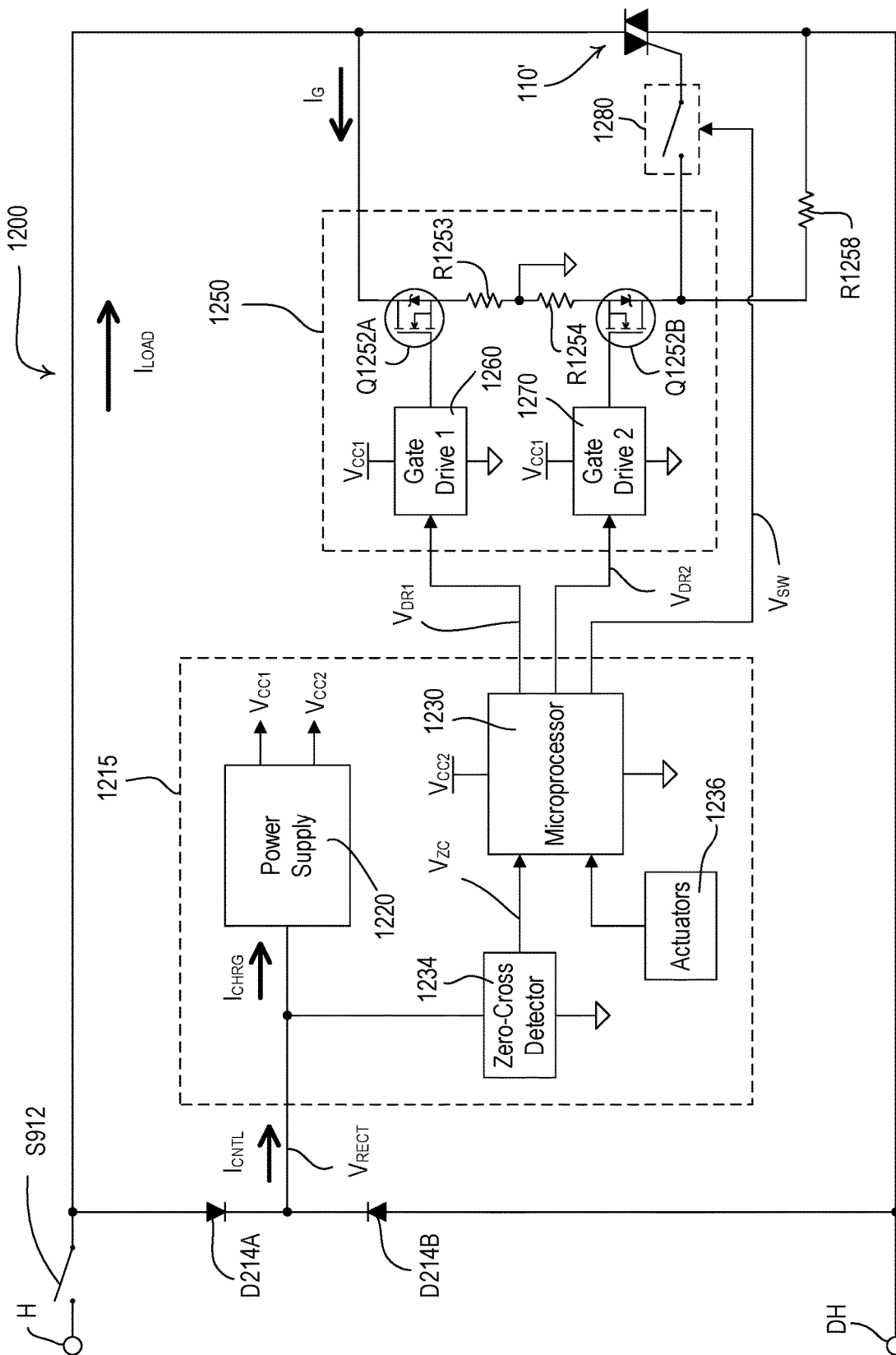
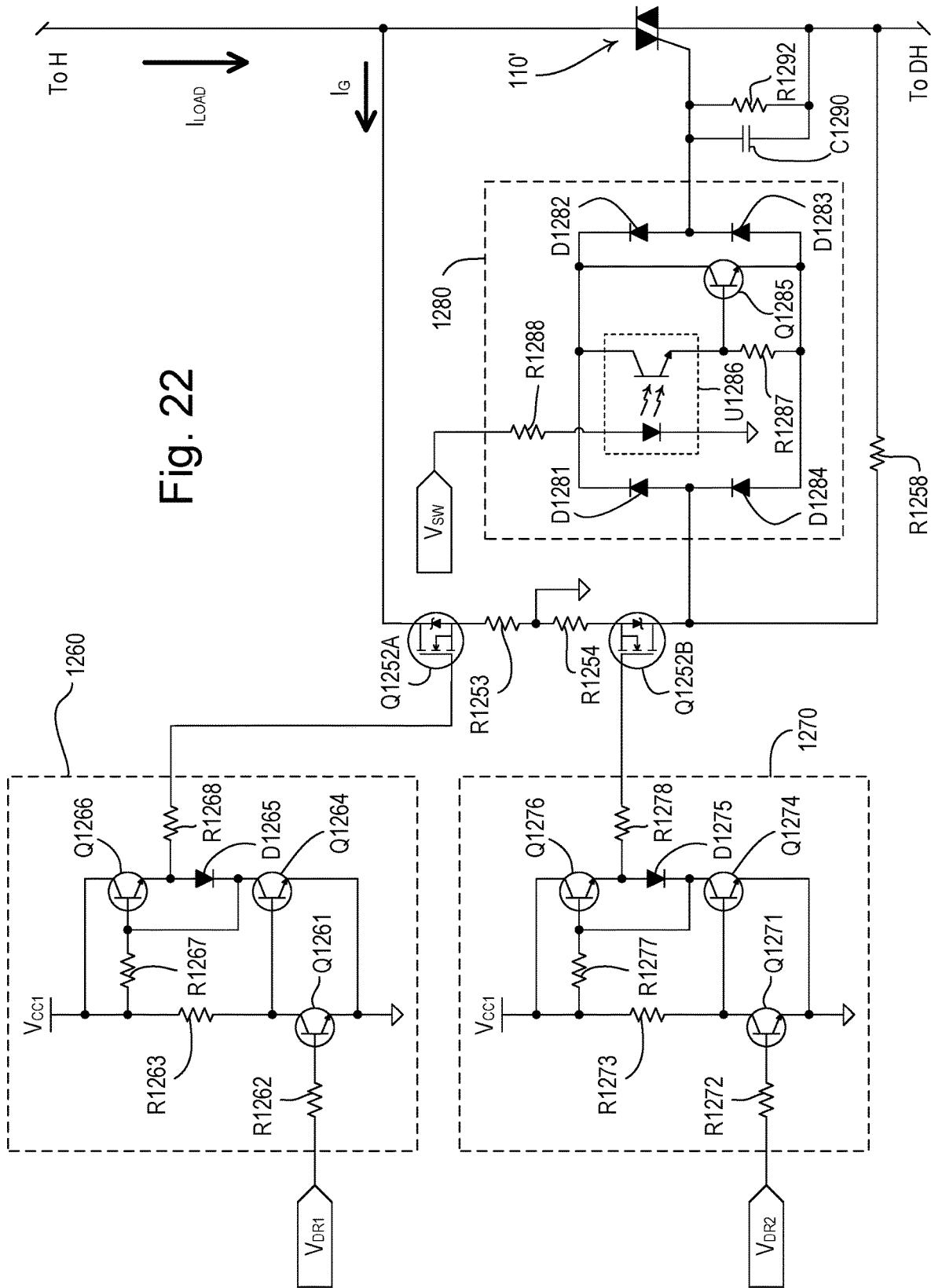

Fig. 21

Fig. 22





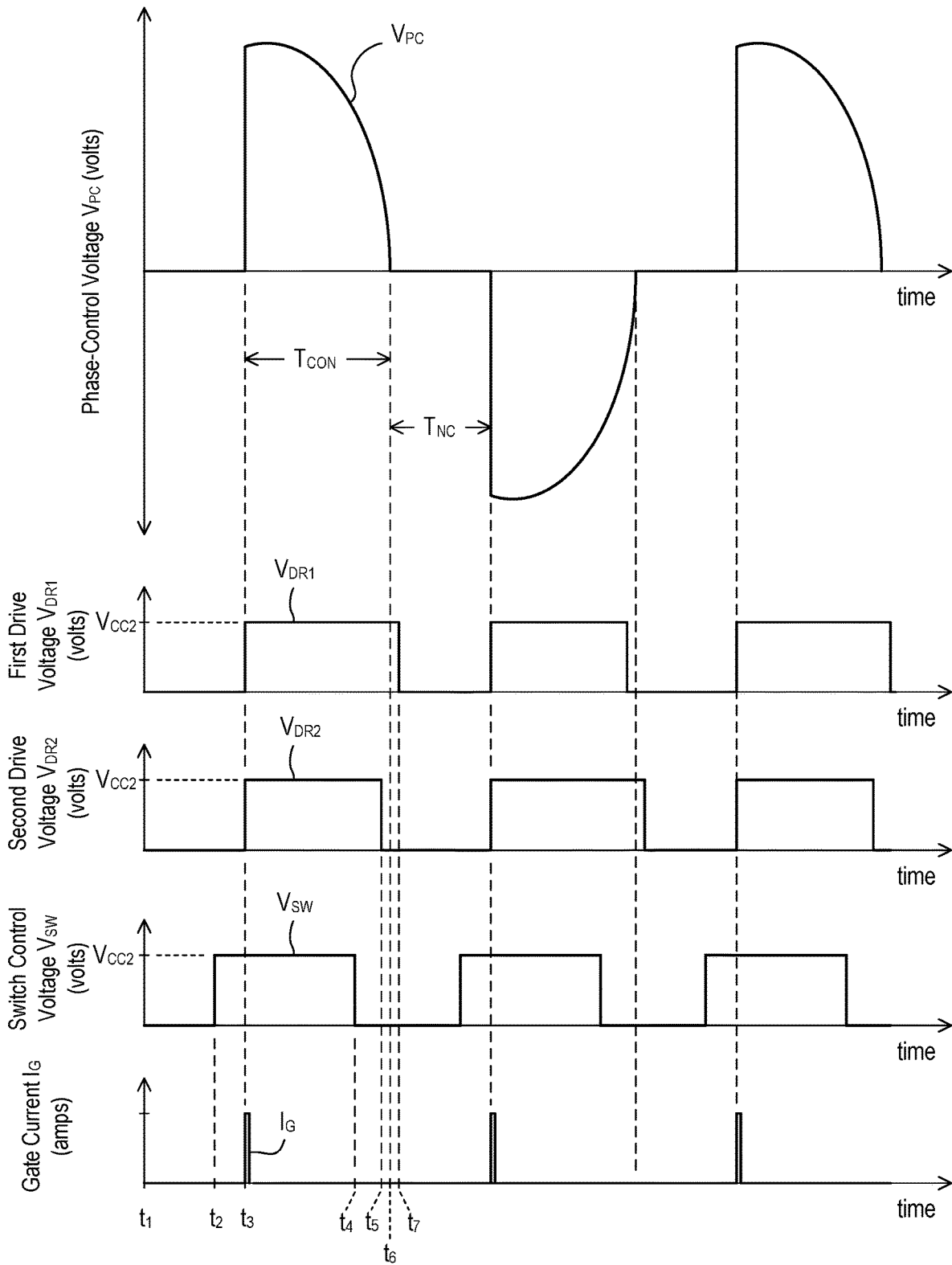

Fig. 23

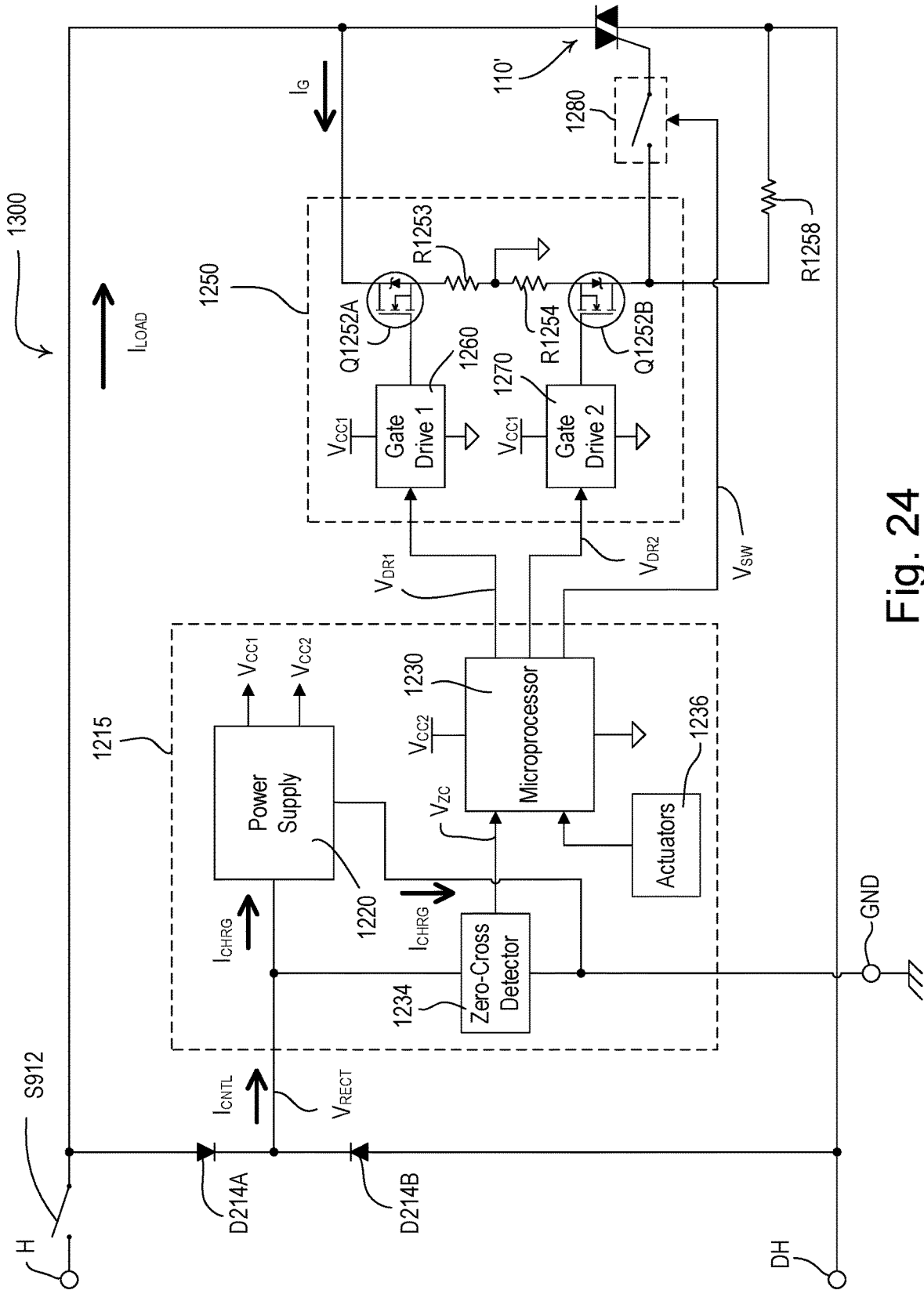

Fig. 24

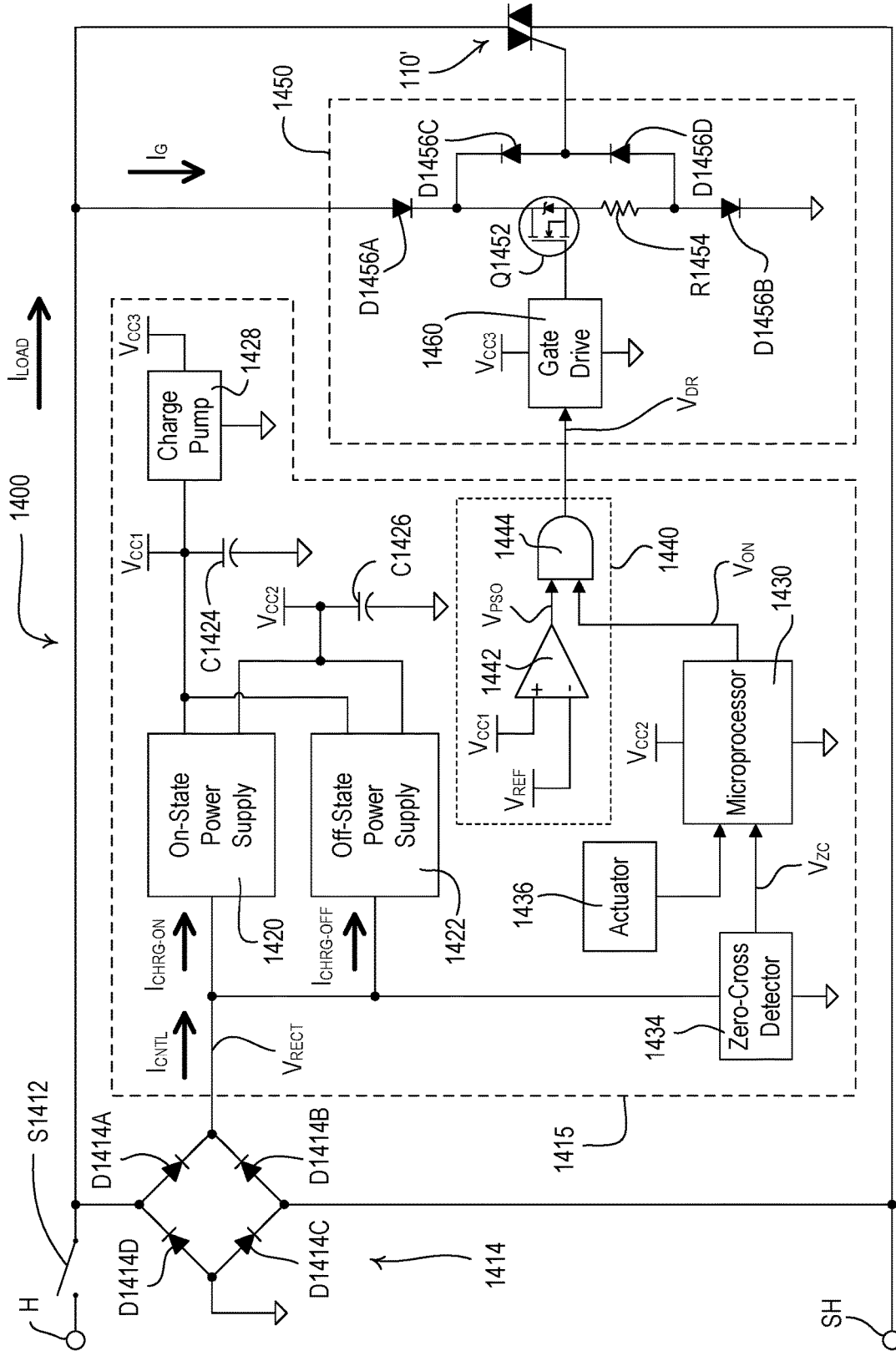

Fig. 25

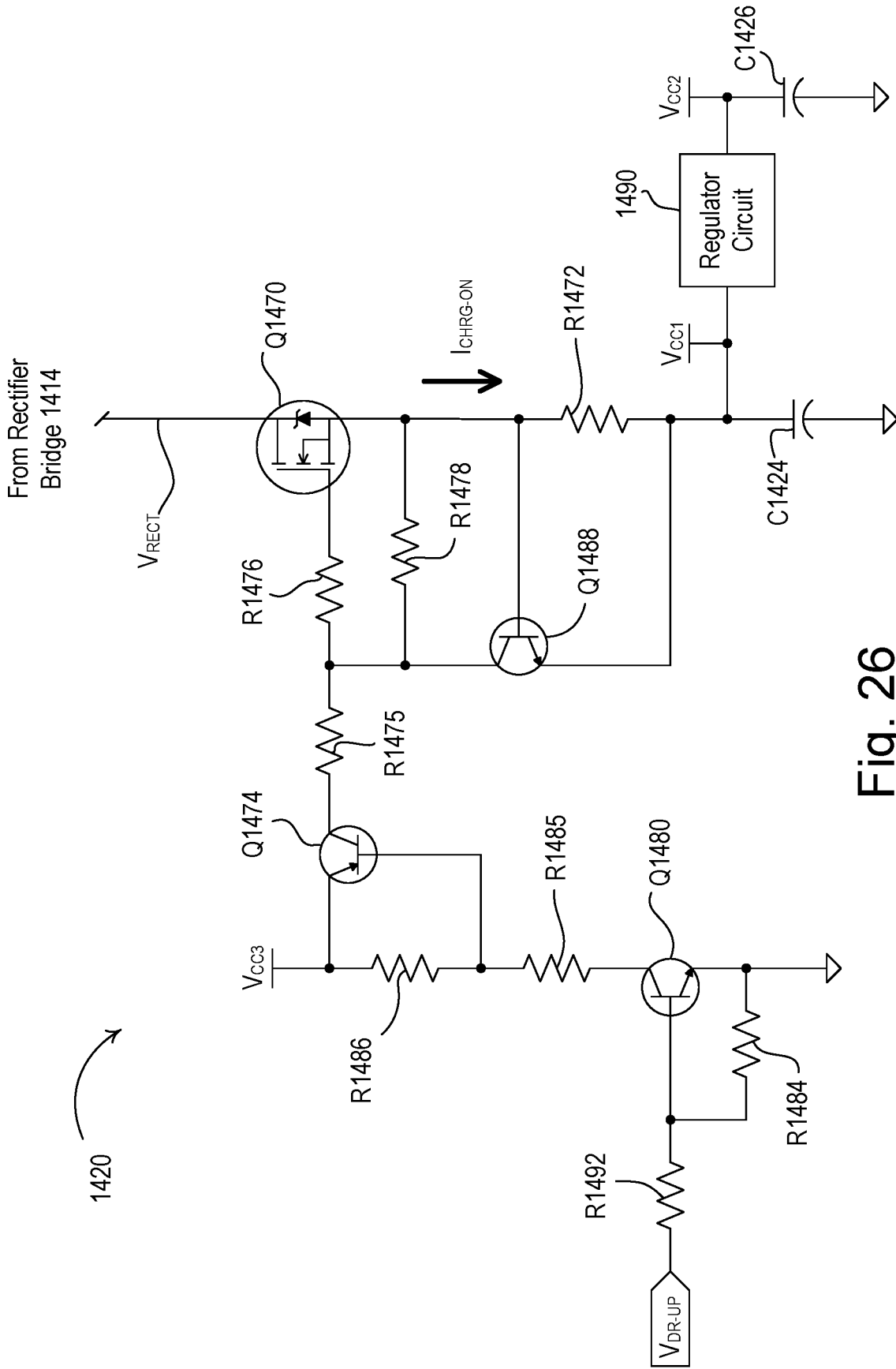

Fig. 26

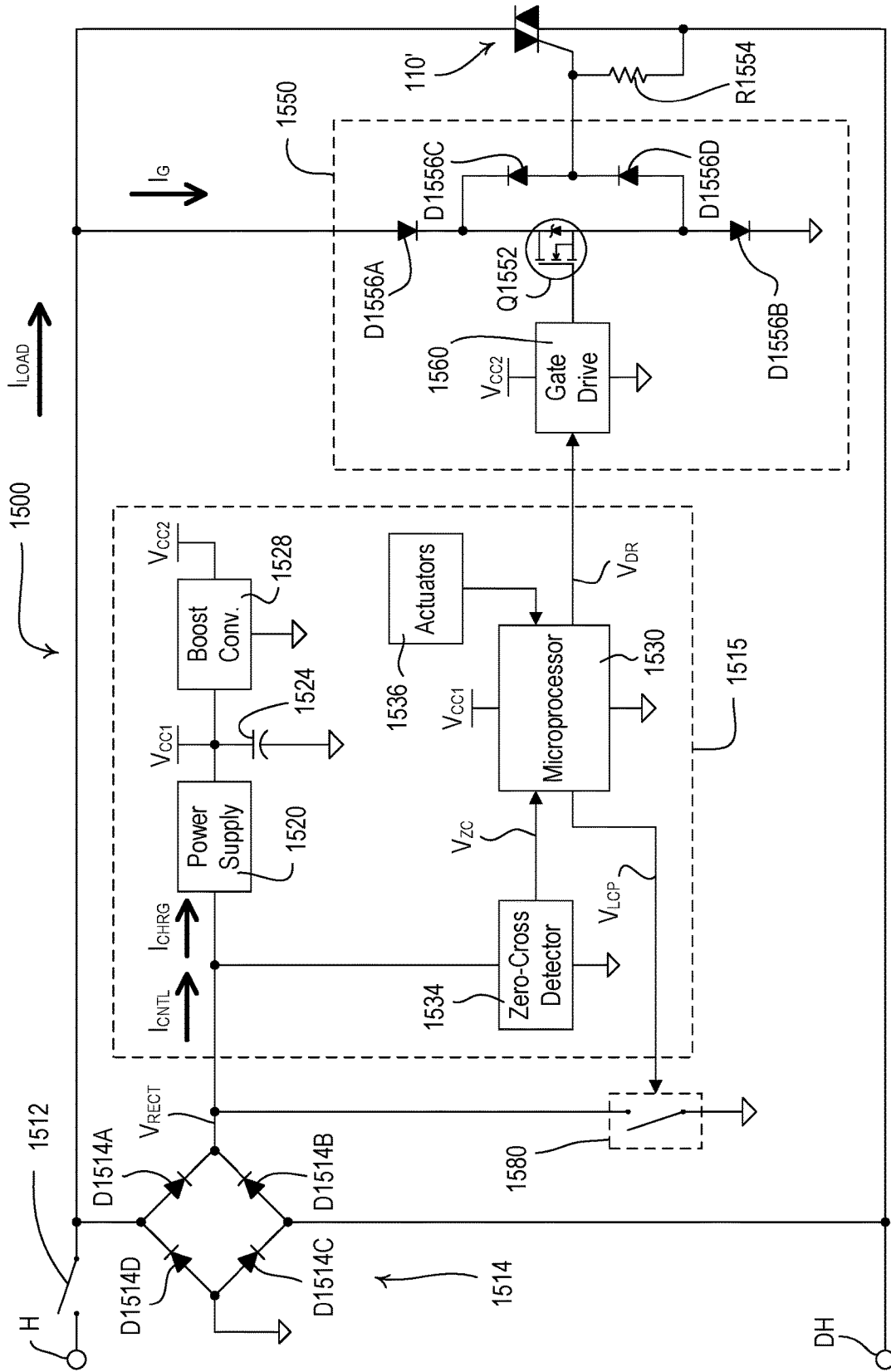

Fig. 27

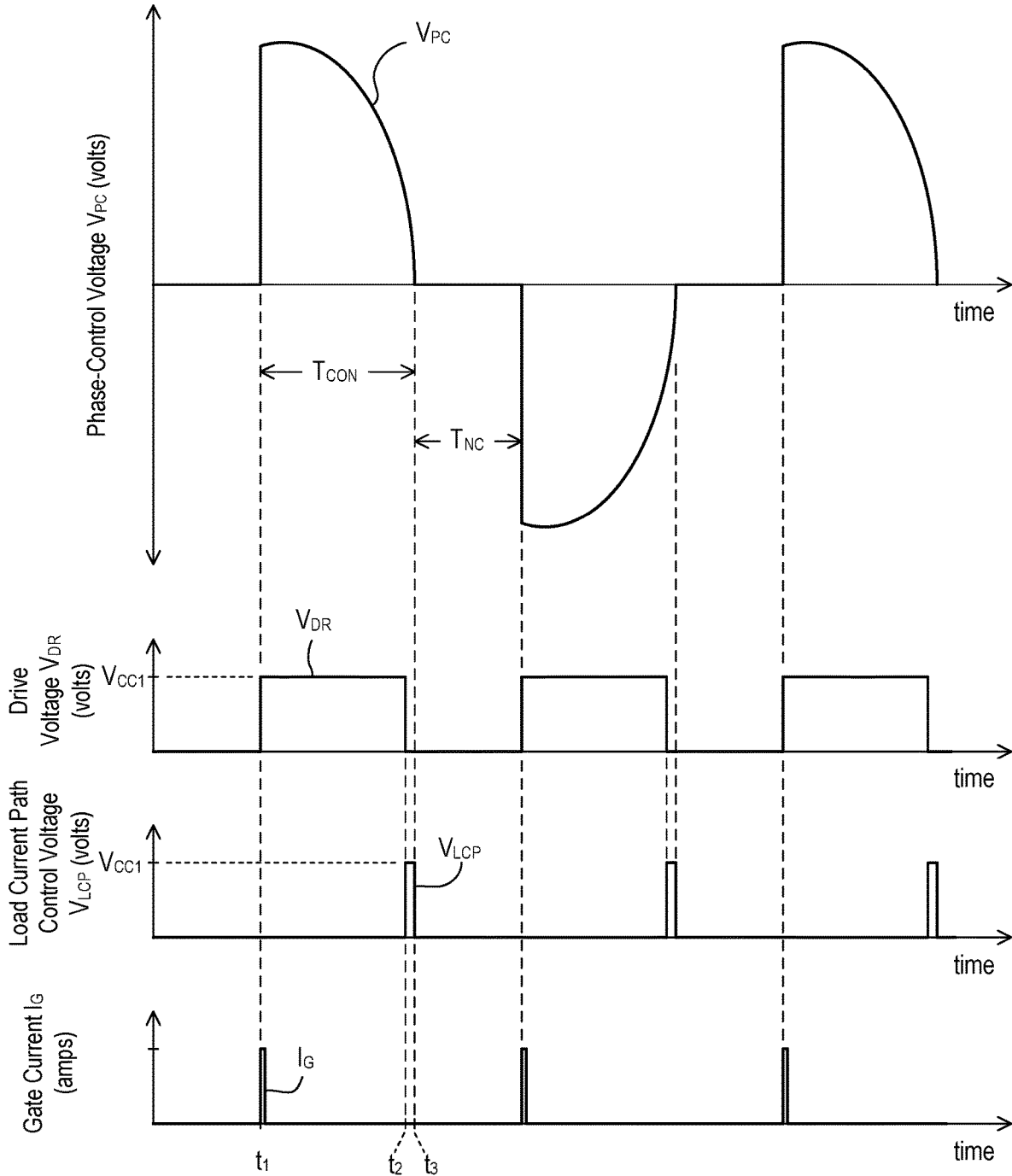

Fig. 28

## LOAD CONTROL DEVICE FOR HIGH-EFFICIENCY LOADS

### CROSS REFERENCE TO RELATED APPLICATIONS

[0001] The present application is a continuation of U.S. Ser. No. 16/713,377, filed on Dec. 13, 2019, which is a continuation of U.S. Ser. No. 16/186,804, filed Nov. 12, 2018, now U.S. Pat. No. 10,530,268, issued Jan. 7, 2020, which is a continuation of U.S. Ser. No. 15/947,216, filed Apr. 6, 2018, which is a continuation of U.S. Ser. No. 15/131,444, filed Apr. 18, 2016, now U.S. Pat. No. 9,941,811, issued Aug. 11, 2016, which is a continuation of U.S. Ser. No. 14/844,252, filed Sep. 3, 2015, now U.S. Pat. No. 9,356,531, issued May 31, 2016, which is a continuation of U.S. Ser. No. 14/153,558, filed Jan. 13, 2014, now U.S. Pat. No. 9,160,224, issued Oct. 13, 2015, which is a continuation-in-part of U.S. Ser. No. 13/775,702, filed Feb. 25, 2013, now U.S. Pat. No. 8,988,050, issued Mar. 24, 2015, which is a continuation-in-part of U.S. Ser. No. 13/458,324, filed Apr. 27, 2012, now U.S. Pat. No. 8,957,662, issued Feb. 17, 2015, which is a continuation-in-part of U.S. Ser. No. 13/232,344, filed Sep. 14, 2011, now U.S. Pat. No. 8,698,408, issued Apr. 15, 2014, which is a continuation-in-part of U.S. Ser. No. 12/952,920, filed Nov. 23, 2010, now U.S. Pat. No. 8,664,881, issued Mar. 4, 2014, which claims priority from U.S. Provisional Patent Application No. 61/264,528, filed Nov. 25, 2009, and U.S. Provisional Patent Application No. 61/333,050, filed May 10, 2010, the entire disclosures of which are hereby incorporated by reference.

### BACKGROUND OF THE INVENTION

#### Field of the Invention

[0002] The present invention relates to load control devices for controlling the amount of power delivered to an electrical load, and more particularly, to an electronic switch for controlling the power delivered to a lighting load.

#### Description of the Related Art

[0003] Prior art two-wire dimmer switches are coupled in series electrical connection between an alternating-current (AC) power source and a lighting load for controlling the amount of power delivered from the AC power source to the lighting load. A two-wire wall-mounted dimmer switch is adapted to be mounted to a standard electrical wallbox and comprises two load terminals: a hot terminal adapted to be coupled to the hot side of the AC power source and a dimmed hot terminal adapted to be coupled to the lighting load. In other words, the two-wire dimmer switch does not require a connection to the neutral side of the AC power source (i.e., the load control device is a “two-wire” device). Prior art “three-way” dimmer switches may be used in three-way lighting systems and comprise at least three load terminals, but do not require a connection to the neutral side of the AC power source.

[0004] The dimmer switch typically comprises a bidirectional semiconductor switch, e.g., a thyristor (such as a triac) or two field-effect transistors (FETs) in anti-series connection. The bidirectional semiconductor switch is coupled in series between the AC power source and the load and is controlled to be conductive and non-conductive for portions of a half cycle of the AC power source to thus

control the amount of power delivered to the electrical load. Generally, dimmer switches use either a forward phase-control dimming technique or a reverse phase-control dimming technique in order to control when the bidirectional semiconductor switch is rendered conductive and non-conductive to thus control the power delivered to the load. The dimmer switch may comprise a toggle actuator for turning the lighting load on and off and an intensity adjustment actuator for adjusting the intensity of the lighting load. Examples of prior art dimmer switches are described in greater detail in commonly-assigned U.S. Pat. No. 5,248,919, issued Sep. 29, 1993, entitled LIGHTING CONTROL DEVICE; U.S. Pat. No. 6,969,959, issued Nov. 29, 2005, entitled ELECTRONIC CONTROL SYSTEMS AND METHODS; and U.S. Pat. No. 7,687,940, issued Mar. 30, 2010, entitled DIMMER SWITCH FOR USE WITH LIGHTING CIRCUITS HAVING THREE-WAY SWITCHES, the entire disclosures of which are hereby incorporated by reference.

[0005] With forward phase-control dimming, the bidirectional semiconductor switch is rendered conductive at some point within each AC line voltage half cycle and remains conductive until approximately the next voltage zero-crossing, such that the bidirectional semiconductor switch is conductive for a conduction time each half cycle. A zero-crossing is defined as the time at which the AC line voltage transitions from positive to negative polarity, or from negative to positive polarity, at the beginning of each half cycle. Forward phase-control dimming is often used to control energy delivered to a resistive or inductive load, which may include, for example, an incandescent lamp or a magnetic low-voltage transformer. The bidirectional semiconductor switch of a forward phase-control dimmer switch is typically implemented as a thyristor, such as a triac or two silicon-controlled rectifiers (SCRs) coupled in anti-parallel connection, since a thyristor becomes non-conductive when the magnitude of the current conducted through the thyristor decreases to approximately zero amps.

[0006] Many forward phase-control dimmers include analog control circuits (such as timing circuits) for controlling when the thyristor is rendered conductive each half cycle of the AC power source. The analog control circuit typically comprises a potentiometer, which may be adjusted in response to a user input provided from, for example, a linear slider control or a rotary knob in order to control the amount of power delivered to the lighting load. The analog control circuit is typically coupled in parallel with the thyristor and conducts a small timing current through the lighting load when the thyristor is non-conductive. The magnitude of the timing current is small enough such that the controlled lighting load is not illuminated to a level that is perceptible to the human eye when the lighting load is off.

[0007] Thyristors are typically characterized by a rated latching current and a rated holding current, and comprise two main load terminals and a control terminal (i.e., a gate). The current conducted through the main terminals of the thyristor must exceed the latching current for the thyristor to become fully conductive. In addition, the current conducted through the main terminals of the thyristor must remain above the holding current for the thyristor to remain in full conduction. Since an incandescent lamp is a resistive lighting load, a typical forward phase-control dimmer switch is operable to conduct enough current through the incandescent lamp to exceed the rated latching and holding currents

of the thyristor if the impedance of the incandescent lamp is low enough. Therefore, prior art forward phase-control dimmer switches are typically rated to operate appropriately with lighting loads having a power rating above a minimum power rating (e.g., approximately 40 W) to guarantee that the thyristor will be able to latch and remained latched when dimming the lighting load.

**[0008]** Some prior art dimmer switches have included two triacs coupled together to overcome some of the problems related to the rated latching and holding currents of triacs as described in greater detail in commonly-assigned U.S. Pat. No. 4,954,768, issued Sep. 4, 1990, entitled TWO WIRE LOW VOLTAGE DIMMER. Such a prior art dimmer switch may comprise a first triac characterized by a low power rating and low latching and holding currents, and a second triac characterized by a high power rating and high latching and holding currents. The main load terminals of the first triac are coupled between one of the main load terminals and the gate of the second triac. In addition, a resistor is coupled between the other main load terminal and the gate of the second triac. If the magnitude of the load current is small, the first triac is rendered conductive when a pulse of current is conducted through the gate and remains latched until the magnitude of the load current drops below the holding current of the first triac (e.g., at the end of a half cycle). If the magnitude of the load current is large, the first triac conducts a pulse of the gate current through the gate of the second triac to render the second triac conductive and the second triac conducts the load current. Since the voltage across the first triac drops to approximately zero volts when the second triac is conductive, the first triac becomes non-conductive after the second triac is rendered conductive. The second triac remains conductive until the magnitude of the load current drops below the holding current of the second triac (e.g., at the end of a half cycle).

**[0009]** When using reverse phase-control dimming, the bidirectional semiconductor switch is rendered conductive at the zero-crossing of the AC line voltage and rendered non-conductive at some point within each half cycle of the AC line voltage, such that the bidirectional semiconductor switch is conductive for a conduction time each half cycle. Reverse phase-control dimming is often used to control energy to a capacitive load, which may include, for example, an electronic low-voltage transformer. Since the bidirectional semiconductor switch must be rendered conductive at the beginning of the half cycle, and must be able to be rendered non-conductive within the half cycle, reverse phase-control dimming requires that the dimmer switch have two FETs in anti-serial connection, or the like. A FET is operable to be rendered conductive and to remain conductive independent of the magnitude of the current conducted through the FET. In other words, a FET is not limited by a rated latching or holding current as is a thyristor. However, prior art reverse phase-control dimmer switches have either required neutral connections and/or advanced control circuits (such as microprocessors) for controlling the operation of the FETs. In order to power a microprocessor, the dimmer switch must also comprise a power supply, which is typically coupled in parallel with the FETs. These advanced control circuits and power supplies add to the cost of prior art FET-based reverse phase-control dimmer switches (as compared to analog forward phase-control dimmer switches).

**[0010]** Further, in order to properly charge, the power supply of such a two-wire dimmer switch must develop an amount of voltage across the power supply and must conduct a charging current from the AC power source through the electrical load, in many instances even when the lighting load is off. If the power rating of the lighting load is too low, the charging current conducted by the power supply through the lighting load may be great enough to cause the lighting load to illuminate to a level that is perceptible to the human eye when the lighting load is off. Therefore, prior art FET-based reverse phase-control dimmer switches are typically rated to operate appropriately with lighting loads having a power rating above a minimum power rating to guarantee that the lighting load does not illuminate to a level that is perceptible to the human eye due to the power supply current when the lighting load is off. Some prior art load control devices, have included power supplies that only develop small voltages and draw small currents when charging, such that the minimum power rating of a controlling lighting load may be as low as 10 W. An example of such a power supply is described in greater detail in commonly-assigned U.S. patent application Ser. No. 12/751,324, filed Mar. 31, 2010, entitled SMART ELECTRONIC SWITCH FOR LOW-POWER LOADS, the entire disclosure of which is hereby incorporated by reference.

**[0011]** Nevertheless, it is desirable to be able to control the amount of power to electrical loads having power rating lower than those able to be controlled by the prior art forward and reverse phase-control dimmer switches. In order to save energy, high-efficiency lighting loads, such as, for example, compact fluorescent lamps (CFLs) and light-emitting diode (LED) light sources, are being used in place of or as replacements for conventional incandescent or halogen lamps. High-efficiency light sources typically consume less power and provide longer operational lives as compared to incandescent and halogen lamps. In order to illuminate properly, a load regulation device (e.g., such as an electronic dimming ballast or an LED driver) must be coupled between the AC power source and the respective high-efficiency light source (i.e., the compact fluorescent lamp or the LED light source) for regulating the power supplied to the high-efficiency light source.

**[0012]** A dimmer switch controlling a high-efficiency light source may be coupled in series between the AC power source and the load control device for the high-efficiency light source. Some high-efficiency lighting loads are integrally housed with the load regulation devices in a single enclosure. Such an enclosure may have a screw-in base that allows for mechanical attachment to standard Edison sockets and provide electrical connections to the neutral side of the AC power source and either the hot side of the AC power source or the dimmed-hot terminal of the dimmer switch (e.g., for receipt of the phase-control voltage). The load regulation circuit is operable to control the intensity of the high-efficiency light source to the desired intensity in response to the conduction time of the bidirectional semiconductor switch of the dimmer switch.

**[0013]** However, the load regulation devices for the high-efficiency light sources may have high input impedances or input impedances that vary in magnitude throughout a half cycle. Therefore, when a prior-art forward phase-control dimmer switch is coupled between the AC power source and the load regulation device for the high-efficiency light source, the load control device may not be able to conduct



enough current to exceed the rated latching and/or holding currents of the thyristor. In addition, when a prior-art reverse phase-control dimmer switch is coupled between the AC power source and the load regulation device, the magnitude of the charging current of the power supply may be great enough to cause the load regulation device to illuminate the controlled high-efficiency light source to a level that is perceptible by the human eye when the light source should be off.

**[0014]** The impedance characteristics of the load regulation device may negatively affect the magnitude of the phase-control voltage received by the load regulation device, such that the conduction time of the received phase-control voltage is different from the actual conduction time of the bidirectional semiconductor switch of the dimmer switch (e.g., if the load regulation device has a capacitive impedance). Therefore, the load regulation device may control the intensity of the high-efficiency light source to an intensity that is different than the desired intensity as directed by the dimmer switch. In addition, the charging current of the power supply of the dimmer switch may build up charge at the input of a load regulation device having a capacitive input impedance, thus negatively affecting the low-end intensity that may be achieved.

**[0015]** Therefore, there exists a need for a two-wire load control device that may be coupled between an AC power source and a load regulation device for a high-efficiency light source and is able to properly control the intensity of the high-efficiency light source.

#### SUMMARY OF THE INVENTION

**[0016]** According to an embodiment of the present invention, a load control device for controlling the amount of power delivered from an AC power source to an electrical load comprises: (1) a thyristor adapted to be coupled in series electrical connection between the AC power source and the electrical load for conducting a load current from the AC power source to the electrical load, the thyristor having a gate for conducting a gate current to render the thyristor conductive; (2) a gate coupling circuit coupled to conduct the gate current through the gate of the thyristor; and (3) a control circuit operable to control the gate coupling circuit to conduct the gate current through a first current path to render the thyristor conductive at a firing time during a half cycle of the AC power source. The control circuit continues to control the gate coupling circuit, such that the gate coupling circuit is able to conduct the gate current through the first current path again after the firing time. The gate current is not able to be conducted through the gate of the thyristor from a transition time before the end of the half-cycle until approximately the end of the half-cycle. The load current is able to be conducted from the AC power source to the electrical load through a second current path after the transition time until approximately the end of the half-cycle.

**[0017]** According to another embodiment of the present invention, a load control device for controlling the amount of power delivered from an AC power source to an electrical load comprises: (1) a thyristor having first and second main load terminals adapted to be coupled in series electrical connection between the AC power source and the electrical load for conducting a load current from the AC power source to the electrical load, the thyristor having a gate for conducting a gate current to render the thyristor conductive; (2) a gate coupling circuit coupled between the first main load

terminal and the gate of the thyristor to conduct the gate current through the gate of the thyristor; (3) a controllable switching circuit coupled in parallel electrical connection with the thyristor; and (4) a control circuit operatively coupled to the gate coupling circuit and the controllable switching circuit. The control circuit is operable to render the gate coupling circuit conductive to conduct the gate current to render the thyristor conductive at a firing time during a half cycle of the AC power source. The control circuit continues to render the gate coupling circuit conductive, such that the gate coupling circuit is able to conduct the gate current again after the firing time. The control circuit renders the gate current coupling circuit non-conductive at a transition time after the firing time and before the end of the half-cycle. The control circuit renders the controllable switching circuit conductive at approximately the transition time, such that the controllable switching circuit is able to conduct the load current after the transition time until approximately the end of the half-cycle.

**[0018]** Other features and advantages of the present invention will become apparent from the following description of the invention that refers to the accompanying drawings.

#### BRIEF DESCRIPTION OF THE DRAWINGS

**[0019]** The invention will now be described in greater detail in the following detailed description with reference to the drawings in which:

**[0020]** FIG. 1 is a simplified block diagram of a lighting control system including a two-wire analog dimmer switch for controlling the intensity of an LED light source according to a first embodiment of the present invention;

**[0021]** FIG. 2 is a simplified block diagram of the dimmer switch of FIG. 1 according to the first embodiment of the present invention;

**[0022]** FIGS. 3A and 3B show example waveforms illustrating the operation of the dimmer switch of FIG. 1 according to the first embodiment of the present invention;

**[0023]** FIG. 4 is a simplified schematic diagram of the dimmer switch of FIG. 2 according to the first embodiment of the present invention;

**[0024]** FIG. 5 is a simplified schematic diagram of a timing circuit of the dimmer switch of FIG. 2;

**[0025]** FIG. 6 is a simplified schematic diagram of a dimmer switch according to a second embodiment of the present invention;

**[0026]** FIG. 7 shows example waveforms illustrating the operation of the dimmer switch of FIG. 6 according to the second embodiment of the present invention;

**[0027]** FIG. 8 is a simplified schematic diagram of a dimmer switch according to a third embodiment of the present invention;

**[0028]** FIG. 9 is a simplified block diagram of a reverse-phase control dimmer switch according to a fourth embodiment of the present invention;

**[0029]** FIG. 10 is a simplified timing diagram showing examples of waveforms illustrating the operation of the dimmer switch of FIG. 9 according to the fourth embodiment of the present invention;

**[0030]** FIG. 11 is a simplified schematic diagram of the dimmer switch of FIG. 9 according to the fourth embodiment of the present invention;

**[0031]** FIG. 12 is a simplified schematic diagram of a dimmer switch according to an alternate embodiment of the present invention;

[0032] FIG. 13 is a simplified schematic diagram of a dimmer switch according to a fifth embodiment of the present invention;

[0033] FIG. 14 is a simplified timing diagram showing examples of waveforms illustrating the operation of the dimmer switch of FIG. 13 according to the fifth embodiment of the present invention;

[0034] FIG. 15 is a simplified schematic diagram of a dimmer switch according to a sixth embodiment of the present invention;

[0035] FIG. 16 is a simplified schematic diagram of a dimmer switch according to a seventh embodiment of the present invention;

[0036] FIG. 17 is a simplified schematic diagram of a dimmer switch according to an eighth embodiment of the present invention;

[0037] FIG. 18 is a simplified schematic diagram of a dimmer switch having a digital control circuit according to a ninth embodiment of the present invention;

[0038] FIG. 19 is a simplified flowchart of a switch procedure executed by a microprocessor of the dimmer switch of FIG. 18 according to the ninth embodiment of the present invention;

[0039] FIG. 20 is a simplified flowchart of a control procedure periodically executed by the microprocessor of the dimmer switch of FIG. 18 according to the ninth embodiment of the present invention;

[0040] FIG. 21 is a simplified schematic diagram of a dimmer switch according to a tenth embodiment of the present invention;

[0041] FIG. 22 is a simplified schematic diagram of a portion of the dimmer switch of FIG. 21 showing first and second gate drive circuits and a controllable switching circuit in greater detail;

[0042] FIG. 23 shows example waveforms illustrating the operation of the dimmer switch of FIG. 21 according to the tenth embodiment of the present invention;

[0043] FIG. 24 is a simplified block diagram of a dimmer switch according to an eleventh embodiment of the present invention;

[0044] FIG. 25 is a simplified block diagram of an electronic switch according to a twelfth embodiment of the present invention;

[0045] FIG. 26 is a simplified schematic diagram of an on-state power supply of the electronic switch of the twelfth embodiment;

[0046] FIG. 27 is a simplified block diagram of a dimmer switch according to a thirteenth embodiment of the present invention; and

[0047] FIG. 28 shows example waveforms illustrating the operation of the dimmer switch of FIG. 24 according to the thirteenth embodiment of the present invention.

#### DETAILED DESCRIPTION OF THE INVENTION

[0048] The foregoing summary, as well as the following detailed description of the preferred embodiments, is better understood when read in conjunction with the appended drawings. For the purposes of illustrating the invention, there is shown in the drawings an embodiment that is presently preferred, in which like numerals represent similar parts throughout the several views of the drawings, it being understood, however, that the invention is not limited to the specific methods and instrumentalities disclosed.

[0049] FIG. 1 is a simplified block diagram of a lighting control system 10 including a “two-wire” dimmer switch 100 for controlling the amount of power delivered to a high-efficiency lighting load 101 including a load regulation device, e.g., a light-emitting diode (LED) driver 102, and a high-efficiency light source, e.g., an LED light source 104 (or “light engine”). The dimmer switch 100 has a hot terminal H coupled to an alternating-current (AC) power source 105 for receiving an AC mains line voltage  $V_{AC}$ , and a dimmed-hot terminal DH coupled to the LED driver 102. The dimmer switch 100 does not require a direct connection to the neutral side N of the AC power source 105. The dimmer switch 100 generates a phase-control voltage  $V_{PC}$  (e.g., a dimmed-hot voltage) at the dimmed-hot terminal DH and conducts a load current  $I_{LOAD}$  through the LED driver 102. The dimmer switch 100 may either use forward phase-control dimming or reverse phase-control dimming techniques to generate the phase-control voltage  $V_{PC}$ .

[0050] As defined herein, a “two-wire” dimmer switch or load control device does not require a direct connection to the neutral side N of the AC power source 105. In other words, all currents conducted by the two-wire dimmer switch must also be conducted through the load. A two-wire dimmer switch may have only two terminals (i.e., the hot terminal H and the dimmed hot terminal DH as shown in FIG. 1). Alternatively, a two-wire dimmer switch (as defined herein) could comprise a three-way dimmer switch that may be used in a three-way lighting system and has at least three load terminals, but does not require a neutral connection. In addition, a two-wire dimmer switch may comprise an additional connection that provides for communication with a remote control device (for remotely controlling the dimmer switch), but does not require the dimmer switch to be directly connected to neutral.

[0051] The LED driver 102 and the LED light source 104 may be both included together in a single enclosure, for example, having a screw-in base adapted to be coupled to a standard Edison socket. When the LED driver 102 is included with the LED light source 104 in the single enclosure, the LED driver only has two electrical connections: to the dimmer switch 100 for receiving the phase-control voltage  $V_{PC}$  and to the neutral side N of the AC power source 105. The LED driver 102 comprises a rectifier bridge circuit 106 that receives the phase-control voltage  $V_{PC}$  and generates a bus voltage  $V_{BUS}$  across a bus capacitor  $C_{BUS}$ . The LED driver 102 further comprises a load control circuit 107 that receives the bus voltage  $V_{BUS}$  and controls the intensity of the LED light source 104 in response to the phase-control signal  $V_{PC}$ . Specifically, the load control circuit 107 of the LED driver 102 is operable to turn the LED light source 104 on and off and to adjust the intensity of the LED light source to a target intensity  $L_{TRGT}$  (i.e., a desired intensity) in response to the phase-control signal  $V_{PC}$ . The target intensity  $L_{TRGT}$  may range between a low-end intensity  $L_{LE}$  (e.g., approximately 1%) and a high-end intensity  $L_{HE}$  (e.g., approximately 100%). The LED driver 102 may also comprise a filter network 108 for preventing noise generated by the load control circuit 107 from being conducted on the AC mains wiring. Since the LED driver 102 comprises the bus capacitor  $C_{BUS}$  and the filter network 108, the LED driver may have a capacitive input impedance. An example of the LED driver 102 is described in greater detail in U.S. patent application Ser. No. 12/813,908, filed Jun. 11, 2009, entitled LOAD CONTROL DEVICE FOR A LIGHT-

EMITTING DIODE LIGHT SOURCE, the entire disclosure of which is hereby incorporated by reference.

**[0052]** In addition, the LED driver **102** may comprise an artificial load circuit **109** for conducting current (in addition to the load current  $I_{LOAD}$ ) through the dimmer switch **100**. Accordingly, if the dimmer switch **100** includes a triac for generating the phase-control voltage  $V_{PC}$ , the artificial load circuit **109** may conduct enough current to ensure that the magnitude of the total current conducted through the triac of the dimmer switch **100** exceeds the rated latching and holding currents of the triac. In addition, the artificial load circuit **109** may conduct a timing current if the dimmer switch **100** comprises a timing circuit and may conduct a charging current if the dimmer switch comprises a power supply, such that these currents need not be conducted through the load control circuit **107** and do not affect the intensity of the LED light source **104**.

**[0053]** The artificial load circuit **109** may simply comprise a constant impedance circuit (e.g., a resistor) or may comprise a current source circuit. Alternatively, the artificial load circuit **109** may be controllable, such that the artificial load circuit may be enabled and disabled to thus selectively conduct current through the dimmer switch **100**. In addition, the artificial load circuit **109** may be controlled to conduct different amounts of current depending upon the magnitude of the AC mains line voltage  $V_{AC}$ , the present time during a half cycle of the AC mains line voltage, or the present operating mode of the LED driver **102**. Examples of artificial load circuits are described in greater detail in commonly-assigned U.S. patent application Ser. No. 12/438,587, filed Aug. 5, 2009, entitled VARIABLE LOAD CIRCUITS FOR USE WITH LIGHTING CONTROL DEVICES, and U.S. patent application Ser. No. 12/950,079, filed Nov. 19, 2010, entitled CONTROLLABLE-LOAD CIRCUIT FOR USE WITH A LOAD CONTROL DEVICE, the entire disclosures of which are hereby incorporated by reference.

**[0054]** Alternatively, the high-efficiency light source could comprise a compact fluorescent lamp (CFL) and the load regulation device could comprise an electronic dimming ballast. In addition, the dimmer switch **100** could alternatively control the amount of power delivered to other types of electrical loads, for example, by directly controlling a lighting load or a motor load. An example of a screw-in light source having a fluorescent lamp and an electronic dimming ballast is described in greater detail in U.S. patent application Ser. No. 12/704,781, filed Feb. 12, 2010, entitled HYBRID LIGHT SOURCE, the entire disclosure of which is hereby incorporated by reference.

**[0055]** The dimmer switch **100** comprises a user interface having a rocker switch **116** and an intensity adjustment actuator **118** (e.g., a slider knob as shown in FIG. 1). The rocker switch **116** allows for turning on and off the LED light source **104**, while the intensity adjustment actuator **118** allows for adjustment of the target intensity  $L_{TRGT}$  of the LED light source **104** from the low-end intensity  $L_{EE}$  to the high-end intensity  $L_{HE}$ . Examples of user interfaces of dimmer switches are described in greater detail in commonly-assigned U.S. patent application Ser. No. 12/363,258, filed Jan. 30, 2009, entitled LOAD CONTROL DEVICE HAVING A VISUAL INDICATION OF ENERGY SAVINGS AND USAGE INFORMATION, the entire disclosure of which is hereby incorporated by reference.

**[0056]** FIG. 2 is a simplified block diagram of the dimmer switch **100** according to a first embodiment of the present

invention. FIGS. 3A and 3B show example waveforms illustrating the operation of the dimmer switch **100** according to the first embodiment of the present invention. The dimmer switch **100** comprises a bidirectional semiconductor switch **110** coupled between the hot terminal H and the dimmed hot terminal DH for generating the phase-control voltage  $V_{PC}$  (as shown in FIGS. 3A and 3B) and controlling of the amount of power delivered to the LED driver **102**. The bidirectional semiconductor switch **110** comprises a control input (e.g., a gate), which may receive control signals for rendering the bidirectional semiconductor switch conductive and non-conductive. The bidirectional semiconductor switch **110** may comprise a single device, such as a triac, or a combination of devices, such as, two field-effect transistors (FETs) coupled in anti-series connection. According to the first embodiment of the present invention, the phase-control voltage  $V_{PC}$  comprises a forward phase-control voltage. In other words, the phase-control voltage  $V_{PC}$  has a magnitude of approximately zero volts at the beginning of each half cycle during a non-conduction time  $T_{NC}$ , and has a magnitude equal to approximately the magnitude of the AC line voltage  $V_{AC}$  of the AC power source **105** during the rest of the half cycle, i.e., during a conduction time  $T_{CON}$ . For example, the conduction time  $T_{CON}$  may be approximately two milliseconds when the target intensity  $L_{TRGT}$  of the LED light source **104** is at the low-end intensity  $L_{EE}$  and approximately seven milliseconds when the target intensity  $L_{TRGT}$  is at the high-end intensity  $L_{HE}$ .

**[0057]** The dimmer switch **100** comprises a mechanical air-gap switch **S112** electrically coupled to the hot terminal H and in series with the bidirectional semiconductor switch **110**, such that the LED light source **104** is turned off when the switch is open. When the air-gap switch **S112** is closed, the dimmer switch **100** is operable to control the bidirectional semiconductor switch **110** to control the amount of power delivered to the LED driver **102**. The air-gap switch **S112** is mechanically coupled to the rocker switch **116** of the user interface of the dimmer switch **100**, such that the switch may be opened and closed in response to actuations of the rocker switch. The dimmer switch **100** further comprises a rectifier circuit **114** coupled across the bidirectional semiconductor switch **110** and operable to generate a rectified voltage  $V_{RECT}$  (i.e., a signal representative of the voltage developed across the bidirectional semiconductor switch).

**[0058]** According to the first embodiment, the dimmer switch **100** comprises an analog control circuit **115** including a power supply **120**, a constant-rate one-shot timing circuit **130**, and a variable-threshold trigger circuit **140** (i.e., a gate drive circuit). The control circuit **115** receives the rectified voltage  $V_{RECT}$  from the rectifier circuit **114** and conducts a control current  $I_{CNTL}$  through the load (i.e., the LED driver **102**) in order to generate a drive voltage  $V_{DR}$  (i.e., a drive signal) for controlling the bidirectional semiconductor switch **110** to thus adjust the intensity of the LED light source **104** in response to the intensity adjustment actuator **118**. The power supply **120** of the control circuit **115** conducts a charging current  $I_{CHRG}$  through the LED driver **102** in order to generate a supply voltage  $V_{CC}$  (e.g., approximately 11.4 volts). The charging current  $I_{CHRG}$  of the power supply makes up a portion of the control current  $I_{CNTL}$  of the control circuit **115**.

**[0059]** The timing circuit **130** receives the supply voltage  $V_{CC}$  and generates a timing voltage  $V_{TIM}$  (i.e., a timing signal), which comprises a ramp signal having a constant

rate of increasing magnitude (i.e., a constant positive slope) as shown in FIGS. 3A and 3B. When the bidirectional semiconductor switch **110** is non-conductive at the beginning of each half cycle, the timing circuit **130** also receives the rectified voltage  $V_{RECT}$  and is able to derive zero-crossing timing information from the voltage developed across the LED driver **102** (i.e., from the control current  $I_{CNTL}$  conducted through the LED driver **102**). The timing voltage  $V_{TIM}$  begins increasing from approximately zero volts shortly after the zero-crossings of the AC line voltage  $V_{AC}$  (i.e., shortly after the beginning of each half cycle as shown at times  $t_1$ ,  $t_4$  in FIGS. 3A and 3B) and continues increasing at the constant rate. After a fixed amount of time  $T_{TIM}$  has elapsed since the timing voltage  $V_{TIM}$  started increasing from zero volts during the present half cycle, the timing voltage  $V_{TIM}$  is driven to approximately zero volts near the next zero-crossing (i.e., near the end of the present half cycle as shown at time  $t_3$  in FIGS. 3A and 3B). Since the timing voltage  $V_{TIM}$  increases in magnitude at the constant rate for the fixed amount of time  $T_{TIM}$  each half cycle, the timing voltage  $V_{TIM}$  is essentially identical during each half cycle as shown in FIGS. 3A and 3B.

[0060] Referring back to FIG. 2, the variable-threshold trigger circuit **140** receives the timing voltage  $V_{TIM}$  from the timing circuit **130**, and generates a drive voltage  $V_{DR}$  (i.e., a gate drive voltage) for controlling the bidirectional semiconductor switch **110** to thus adjust the intensity of the LED light source **104** in response to actuations of the intensity adjustment actuator **118**. The trigger circuit **140** is characterized by a variable threshold (i.e., a variable threshold voltage  $V_{TH}$  shown in FIGS. 3A and 3B) that may be adjusted in response to the intensity adjustment actuator **118** of the user interface of the dimmer switch **100**.

[0061] A gate coupling circuit **150** couples the drive voltage  $V_{DR}$  to the gate of the bidirectional semiconductor switch **110** for thus rendering the bidirectional semiconductor switch **110** conductive and non-conductive in response to the magnitude of the variable threshold voltage  $V_{TH}$ . When the magnitude of the timing voltage  $V_{TIM}$  exceeds the magnitude of a variable threshold voltage  $V_{TH}$  each half cycle (as shown at firing times  $t_2$ ,  $t_5$  in FIGS. 3A and 3B), the trigger circuit **140** is operable to drive the drive voltage  $V_{DR}$  to a first magnitude (e.g., approximately zero volts as shown in FIGS. 3A and 3B) to thus render the bidirectional semiconductor switch **110** conductive each half cycle (as will be described in greater detail below with reference to FIG. 4). The drive voltage  $V_{DR}$  is then driven to a second magnitude (e.g., approximately the supply voltage  $V_{CC}$  as shown in FIGS. 3A and 3B) to render the bidirectional semiconductor switch **110** non-conductive when the timing voltage  $V_{TIM}$  is controlled to approximately zero volts shortly before the next zero-crossing. The variable threshold voltage  $V_{TH}$  is shown at two different magnitudes in FIGS. 3A and 3B, which results in the drive voltage  $V_{DR}$  being driven low to zero volts (and thus rendering the bidirectional semiconductor switch **110** conductive) for different amounts of time.

[0062] As shown in FIGS. 3A and 3B, the control circuit **115** of the dimmer switch **100** is operable to provide a constant gate drive to the bidirectional semiconductor switch **110** by maintaining the drive voltage  $V_{DR}$  low for the remainder of the half cycle after the bidirectional semiconductor switch **110** is rendered conductive (as shown at firing times  $t_2$ ,  $t_5$ ). Accordingly, the bidirectional semiconductor switch **110** will remain conductive independent of the mag-

nitude of the load current  $I_{LOAD}$  conducted through the bidirectional semiconductor switch and the LED driver **102**. When the bidirectional semiconductor switch **110** is conductive and the magnitude of the phase control voltage  $V_{PC}$  is greater than approximately the magnitude of the bus voltage  $V_{BUS}$  of the LED driver **102**, the LED driver **102** will begin to conduct the load current  $I_{LOAD}$  through the bidirectional semiconductor switch. Since the bus capacitor  $C_{BUS}$  of the LED driver **102** may charge quickly, the magnitude of the load current  $I_{LOAD}$  may quickly peak before subsiding down to a substantially small magnitude (e.g., approximately zero amps). As previously mentioned, the bidirectional semiconductor switch **110** will remain conductive independent of the magnitude of the load current  $I_{LOAD}$  because the control circuit **115** is providing constant gate drive to the bidirectional semiconductor switch. In addition to quickly increasing and decreasing in magnitude, the load current  $I_{LOAD}$  may also change direction after the bidirectional semiconductor switch **110** is rendered conductive. Therefore, the bidirectional semiconductor switch **110** is also operable to conduct current in both directions (i.e., to and from the LED driver **102**) after the bidirectional semiconductor switch is rendered conductive during a single half cycle, thereby allowing any capacitors in the filter network **108** of the LED driver **102** to follow the magnitude of the AC line voltage  $V_{AC}$  of the AC power source **105**.

[0063] FIG. 4 is a simplified schematic diagram of the dimmer switch **100**. As shown in FIG. 4, the bidirectional semiconductor switch **110** of the dimmer switch **100** of the first embodiment is implemented as a triac **110'**, but may alternatively be implemented as one or more silicon-controlled rectifiers (SCRs), or any suitable thyristor. The triac **110'** comprises two main terminals that are coupled in series electrical connection between the hot terminal H and the dimmed hot terminal DH, such that the triac is adapted to be coupled in series electrical connection between the AC power source **105** and the LED driver **102** for conducting the load current  $I_{LOAD}$  to the LED driver. The triac **110'** comprises a gate (i.e., a control input) for rendering the triac conductive each half cycle of the AC power source **105** as will be described in greater detail below. While not shown in FIG. 4, a choke inductor may be coupled in series with the triac **110'**, and a filter circuit (such as a filter capacitor) may be coupled between the hot terminal H and the dimmed hot terminal DH (i.e., in parallel with the triac) to prevent noise generated by the switching of the triac from being conducted on the AC mains wiring.

[0064] The rectifier circuit **114** comprises a full-wave rectifier bridge having four diodes D114A, D114B, D114C, D114D. The rectifier bridge of the rectifier circuit **114** has AC terminals coupled in series between the hot terminal H and the dimmed hot terminal DH, and DC terminals for providing the rectified voltage  $V_{RECT}$  to the timing circuit **130** when the triac **110'** is non-conductive and a voltage is developed across the dimmer switch **100**. The control circuit **115** conducts the control current  $I_{CNTL}$  through the rectifier circuit **114** and the LED driver **102**. Accordingly, the total current conducted through the LED driver **102** each half cycle is the sum of the load current  $I_{LOAD}$  conducted through the bidirectional semiconductor switch **110**, the control current  $I_{CNTL}$  conducted through the control circuit **115** of the dimmer switch **100**, and any leakage current conducted through the filter circuit (that may be coupled between the hot terminal H and the dimmed hot terminal DH).

**[0065]** As shown in FIG. 4, the power supply 120 comprises, for example, a pass-transistor circuit that generates the supply voltage  $V_{CC}$ . The pass-transistor circuit comprises an NPN bipolar junction transistor Q122 having a collector coupled to receive the rectifier voltage  $V_{RECT}$  through a resistor R124 (e.g., having a resistance of approximately 100 k $\Omega$ ). The base of the transistor Q122 is coupled to the rectifier voltage  $V_{RECT}$  through a resistor R125 (e.g., having a resistance of approximately 150 k $\Omega$ ), and to circuit common through a zener diode Z126 (e.g., having a break-over voltage of approximately 12 volts). The power supply 120 further comprises a storage capacitor C128, which is able to charge through the transistor Q122 to a voltage equal to approximately the break-over voltage of the zener diode Z126 minus the base-emitter drop of the transistor Q122. The storage capacitor C128 has, for example, a capacitance of approximately 10  $\mu$ F, and operates to maintain the supply voltage  $V_{CC}$  at an appropriate magnitude (i.e., approximately 11.4 volts) to allow the timing circuit 120 to generate the timing voltage  $V_{TIM}$  and the gate coupling circuit 150 to continue rendering the triac 110' conductive after the firing times each half cycle.

**[0066]** The timing circuit 130 comprises a constant ramp circuit 160, a one-shot latch circuit 170, and a reset circuit 180. The constant ramp circuit 160 receives the supply voltage  $V_{CC}$  and causes the timing voltage  $V_{TIM}$  to increase in magnitude at the constant rate. The reset circuit 180 receives the rectified voltage  $V_{RECT}$  and is coupled to the timing voltage  $V_{TIM}$ , such that the reset circuit is operable to start the timing voltage  $V_{TIM}$  increasing in magnitude from approximately zero volts shortly after the beginning of each half cycle at a half cycle start time (e.g., times  $t_1$ ,  $t_4$  in FIGS. 3A and 3B). Specifically, the reset circuit 180 is operable to enable the timing voltage  $V_{TIM}$  (i.e., to start the increase of the magnitude of the timing voltage  $V_{TIM}$ ) in response to a positive-going transition of the rectified voltage  $V_{RECT}$  across a reset threshold  $V_{RST}$  that remains above the reset threshold  $V_{RST}$  for at least a predetermined amount of time. The one-shot latch circuit 170 provides a latch voltage  $V_{LATCH}$  to the reset circuit 180 to prevent the reset circuit 180 from resetting the timing voltage  $V_{TIM}$  until the end of the half cycle, thus ensuring that the reset circuit only restarts the generation of the timing voltage once each half cycle.

**[0067]** The one-shot latch circuit 170 stops the generation of the timing voltage  $V_{TIM}$  by controlling the magnitude of the timing voltage  $V_{TIM}$  to approximately 0.6 volts at the end of the fixed amount of time from when the reset circuit 180 enabled the timing voltage  $V_{TIM}$  (e.g., near the end of the half cycle at time  $t_3$  in FIGS. 3A and 3B). After the one-shot latch circuit 170 controls the magnitude of the timing voltage  $V_{TIM}$  to approximately 0.6 volts, the reset circuit 180 is once again able to enable the generation of the timing voltage  $V_{TIM}$  after the beginning of the next half cycle (i.e., at time  $t_4$  in FIGS. 3A and 3B). As a result, a dead time  $T_{DT}$  exists between the time when the one-shot latch circuit 170 drives the timing voltage  $V_{TIM}$  to approximately 0.6 volts and the reset circuit 180 enables the generation of the timing voltage  $V_{TIM}$  by controlling the magnitude of the timing voltage  $V_{TIM}$  down to approximately zero volts.

**[0068]** The variable-threshold trigger circuit 140 comprises a comparator U142 having an inverting input that receives the timing voltage  $V_{TIM}$  from the timing circuit 130. The variable-threshold trigger circuit 140 also comprises a

potentiometer R144 that is mechanically coupled to the slider knob of the intensity adjustment actuator 118. The potentiometer R144 has a resistive element coupled between the supply voltage  $V_{CC}$  and circuit common and a wiper terminal that generates the variable threshold voltage  $V_{TH}$ . The variable threshold voltage  $V_{TH}$  comprises a DC voltage that varies in magnitude in response to the position of the slider knob of the intensity adjustment actuator 118 and is provided to a non-inverting input of the comparator U142. The drive voltage  $V_{DR}$  is generated at an output of the comparator U142 and is provided to the gate coupling circuit 150 for rendering the triac 110' conductive and non-conductive. The gate coupling circuit 150 comprises an opto-coupler U152 having an input photodiode, which is coupled between the supply voltage  $V_{CC}$  and the output of the comparator U142 and in series with a resistor R154 (e.g., having a resistance of approximately 8.2 k $\Omega$ ). The opto-coupler U152 has an output phototriac that is coupled in series with a resistor R156 (e.g., having a resistance of approximately 100 $\Omega$ ). The series combination of the output phototriac of the opto-coupler U152 and the resistor R156 is coupled between the gate and one of the main terminals of the triac 110' (e.g., to the hot terminal H).

**[0069]** As shown in FIGS. 3A and 3B, when the magnitude of the timing voltage  $V_{TIM}$  is below the magnitude of the variable threshold voltage  $V_{TH}$ , the magnitude of the drive voltage  $V_{DR}$  at the output of the comparator U142 of the variable-threshold trigger circuit 140 remains high at approximately the supply voltage  $V_{CC}$ , such that the triac 110' remains non-conductive. When the magnitude of the timing voltage  $V_{TIM}$  increases above the variable threshold voltage  $V_{TH}$ , the comparator U142 drives the drive voltage  $V_{DR}$  low to approximately circuit common, such that the input photodiode of the opto-coupler U152 conducts a drive current  $I_{DR}$ , which may have an rated magnitude  $I_{DR-RTD}$  of approximately 2 mA. As a result, the output phototriac of the opto-coupler U152 is rendered conductive and conducts a gate current  $I_G$  through the gate of the triac 110', thus rendering the triac conductive. Accordingly, the drive voltage  $V_{DR}$  is driven low to render the triac 110' conductive after a variable amount of time has elapsed since the half cycle start time (i.e., the non-conduction time  $T_{NC}$  as shown in FIGS. 3A and 3B), where the variable amount of time is adjusted in response to intensity adjustment actuator 118 and the variable threshold voltage  $V_{TH}$ . Since the magnitude of the drive voltage  $V_{DR}$  remains low after the triac 110' is rendered conductive, the input photodiode of the opto-coupler U152 continues to conduct the drive current  $I_{DR}$  for the remainder of the half cycle. For example, the input photodiode of the opto-coupler U152 may conduct an average current from the storage capacitor C128 of the power supply 120 where the average current may range from approximately 0.5 milliamps when the target intensity  $L_{TRGT}$  of the LED light source 104 is at the low-end intensity  $L_{LE}$  to approximately 1.7 milliamps when the target intensity  $L_{TRGT}$  is at the high-end intensity  $L_{HE}$ .

**[0070]** As previously mentioned, the load current  $I_{LOAD}$  may change direction after the triac 110' is rendered conductive (i.e., the magnitude of the load current  $I_{LOAD}$  transitions from positive to negative or vice versa). When the magnitude of the load current  $I_{LOAD}$  falls below the holding current of the triac 110', the triac commutates off and becomes non-conductive. In addition, the gate of the triac 110' stops conducting the gate current  $I_G$  and the output

phototriac of the opto-coupler U152 becomes non-conductive. However, because the magnitude of the drive voltage  $V_{DR}$  remains low and accordingly, the input photodiode of the opto-coupler U152 continues to conduct the drive current  $I_{DR}$  (i.e., providing a constant gate drive) even when the triac 110' becomes non-conductive, the output phototriac of the opto-coupler is able to conduct the gate current  $I_G$  and the triac 110' is able to be rendered conductive and conduct the load current  $I_{LOAD}$  in the opposite direction shortly thereafter. Accordingly, the triac 110' is able to conduct the load current  $I_{LOAD}$  in both directions in a single half cycle.

**[0071]** After the triac 110' is rendered conductive each half cycle, the timing circuit 130 continues to generate the timing voltage  $V_{TIM}$ . Thus, the magnitude of the timing voltage  $V_{TIM}$  remains above the variable threshold voltage  $V_{TH}$  and the triac 110' remains conductive until approximately the end of the half cycle when the one-shot latch circuit 170 drives the timing voltage to approximately zero volts. The input photodiode of the opto-coupler U152 continues to conduct the drive current  $I_{DR}$  and the output phototriac continues to conduct the gate current  $I_G$  to render the triac 110' conductive while the drive voltage  $V_{DR}$  is driven low each half cycle (as shown in FIGS. 3A and 3B).

**[0072]** According to the first embodiment of the present invention, the latch circuit 170 is operable to control the timing voltage  $V_{TIM}$  to approximately zero volts (thus controlling the magnitude of the drive voltage  $V_{DR}$  high to approximately the supply voltage  $V_{CC}$ ) shortly before the end of the present half cycle (as shown at time  $t_3$  in FIGS. 3A and 3B). Accordingly, the length of the timing voltage  $V_{TIM}$  (i.e., the fixed amount of time  $T_{TIM}$ ) is slightly smaller than the length  $T_{HC}$  of each half cycle. The dead time  $T_{DT}$  (or "blanking pulse") in the timing voltage  $V_{TIM}$  at the end of the half cycle allows the triac 110' to commutate off (i.e., become non-conductive) when the magnitude of the load current  $I_{LOAD}$  through the triac reduces to approximately zero amps at the end of the half cycle.

**[0073]** Because the LED driver 102 may have a capacitive input impedance, the magnitude of the phase-control voltage  $V_{PC}$  may not quickly decrease to zero volts near the zero-crossing of the AC mains lines voltage  $V_{AC}$  after the triac 110' becomes non-conductive at the end of each half cycle. Therefore, according to the first embodiment of the present invention, the reset circuit 180 only starts the timing voltage  $V_{TIM}$  after a zero-crossing of the AC mains lines voltage  $V_{AC}$ , i.e., in response to the magnitude of the rectified voltage  $V_{RECT}$  exceeding the reset threshold  $V_{RST}$  when the rectified voltage is increasing in magnitude. The reset circuit 180 is prevented from resetting the timing voltage  $V_{TIM}$  in response to the magnitude of the rectified voltage  $V_{RECT}$  dropping below the reset threshold  $V_{RST}$ , which may or may not happen each half cycle due to the capacitive input impedance of the LED driver 102.

**[0074]** FIG. 5 is a simplified schematic diagram of the timing circuit 130. The constant ramp circuit 160 receives the supply voltage  $V_{CC}$  and generates the timing voltage  $V_{TIM}$  across a timing capacitor C162 (e.g., having a capacitance of approximately 50 nF). The constant ramp circuit 160 comprises a constant current source for conducting a constant timing current  $I_{TIM}$  through the timing capacitor C162, such that the timing voltage  $V_{TIM}$  has a constant slope. The constant current source circuit comprises a PNP bipolar junction transistor Q164 having an emitter coupled to the supply voltage  $V_{CC}$  via a resistor R165 (e.g. having a

resistance of approximately 10 kW. Two diodes D166, D168 are coupled in series between the supply voltage  $V_{CC}$  and the base of the transistor Q164. A resistor R169 is coupled between the base of the transistor Q164 and circuit common and has, for example, a resistance of approximately 51 k $\Omega$ . A voltage having a magnitude of approximately the forward voltage drop of the diode D166 (e.g., approximately 0.6 V) is produced across the resistor R165, such that the resistor conducts the constant timing current  $I_{TIM}$  (e.g., approximately 70  $\mu$ A) into the capacitor C162. The rate at which the magnitude of the timing voltage  $V_{TIM}$  increases with respect to time (i.e.,  $dV_{TIM}/dt$ ) is a function of the magnitude of the timing current  $I_{TIM}$  and the capacitance  $C_{C162}$  of the capacitor C162 (i.e.,  $dV_{TIM}/dt=I_{TIM}/C_{C162}$ ), and may be equal to, for example, approximately 1.4 V/msec.

**[0075]** The one-shot latch circuit 170 comprises a comparator U172 having an inverting input coupled to the timing voltage  $V_{TIM}$ . The timing voltage  $V_{TIM}$  is further coupled to an output of the comparator U172 via a diode D174. The one-shot latch circuit 170 includes a resistive divider, which is coupled in series electrical connection between the supply voltage  $V_{CC}$  and circuit common, and comprises two resistors R175, R176 having, for example, resistances of approximately 100 k $\Omega$  and 1 M $\Omega$ , respectively. The junction of the two resistors R175, R176 produces a latch threshold voltage  $V_{TH-L}$ , which is provided to a non-inverting input of the comparator U172. The non-inverting input of the comparator U172 is also coupled to the output via a resistor R178 (e.g., having a resistance of approximately 1 k $\Omega$ ). The latch voltage  $V_{LATCH}$  is generated at the output of the comparator U172 and is provided to the reset circuit 180 as will be described in greater detail below.

**[0076]** The reset circuit 180 comprises a first comparator U181 having a non-inverting input that receives the rectified voltage  $V_{RECT}$  via the series combination of a zener diode Z182 and a resistor R183 (e.g., having a resistance of approximately 100 k $\Omega$ ). The parallel combination of a capacitor C184 (e.g., having a capacitance of approximately 1000 pF) and a resistor R185 (e.g., having a resistance of approximately 20 k $\Omega$ ) is coupled between the non-inverting input of the comparator U181 and circuit common. A zener diode Z186 (e.g., having a break-over voltage of approximately 12 volts) clamps the magnitude of the voltage produced between the non-inverting input of the comparator U181 and circuit common. The reset circuit 180 further comprises a resistive divider that has two resistors R187, R188 (e.g., having resistances of approximately 150 k $\Omega$  and 100 k $\Omega$ , respectively), and is coupled in series electrical connection between the supply voltage  $V_{CC}$  and circuit common. The junction of the two resistors R187, R188 produces a reset threshold voltage  $V_{RST}$  (e.g., approximately 4.8 V), which is provided to an inverting input of the comparator U181. An output of the comparator U181 is coupled to the supply voltage  $V_{CC}$  via a resistor R189 (e.g., having a resistance of approximately 10 k $\Omega$ ).

**[0077]** The reset circuit 180 also comprises a second comparator U191 having a non-inverting input coupled to the threshold voltage  $V_{RST}$  and an output coupled to the timing voltage  $V_{TIM}$ . The output of the comparator U181 is coupled to an inverting input of the second comparator U191 via a capacitor C190 (e.g., having a capacitance of approximately 1000  $\mu$ F). A resistor R192 (e.g., having a resistance of approximately 68 k $\Omega$ ) and a diode D193 are coupled between the inverting input of the comparator U191 and

circuit common. A FET Q194 is also coupled between the inverting input and circuit common. The gate of the FET Q194 is pulled up towards the supply voltage  $V_{CC}$  through a resistor R195 (e.g., having a resistance of approximately 100 k $\Omega$ ), and is coupled to the latch voltage  $V_{LATCH}$ , such that the FET may be rendered conductive and non-conductive in response to the one-shot latch circuit 170.

**[0078]** When the timing voltage  $V_{TIM}$  starts out at approximately zero volts, the inverting input of the comparator U172 of the latch circuit 170 is less than the latch threshold voltage  $V_{TH-L}$  (e.g., approximately 10.5 V) at the non-inverting input and the output is pulled up towards the supply voltage  $V_{CC}$  via the resistor R195 and the diode D196 of the reset circuit 180. The magnitude of the timing voltage  $V_{TIM}$  continues to increase at the constant rate until the magnitude of timing voltage exceeds the latch threshold voltage  $V_{TH-L}$ , at which time, the comparator U172 of the latch circuit 170 drives the output low to approximately zero volts. At this time, the magnitude of the timing voltage  $V_{TIM}$  is reduced to approximately the forward voltage drop of the diode D174 (e.g., approximately 0.6 V). Accordingly, the fixed amount of time  $T_{TIM}$  that the timing voltage  $V_{TIM}$  is generated each half cycle is a function of the constant rate at which the magnitude of the timing voltage  $V_{TIM}$  increases with respect to time  $dV_{TIM}/dt$  (i.e., approximately 1.4 V/msec) and the magnitude of the latch threshold voltage  $V_{TH-L}$  (i.e., approximately 10.5 V), such that the fixed amount of time  $T_{TIM}$  is approximately 7.5 msec each half cycle. After the magnitude of the timing voltage  $V_{TIM}$  has exceeded the latch threshold voltage  $V_{TH-L}$ , the latch threshold voltage  $V_{TH-L}$  is reduced to approximately 0.1 V, such that the comparator U172 continues to drive the output low and the magnitude of the timing voltage  $V_{TIM}$  is maintained at approximately 0.6 V.

**[0079]** At the beginning of a half cycle, the magnitude of the rectified voltage  $V_{RECT}$  is below a break-over voltage of the zener diode Z182 of the reset circuit 180 (e.g., approximately 30 V) and the voltage at the non-inverting input of the first comparator U181 is approximately zero volts, such that the output of the first comparator is driven low towards circuit common. When the magnitude of the rectified voltage  $V_{RECT}$  exceeds approximately the break-over voltage of the zener diode Z182, the capacitor C184 begins to charge until the magnitude of the voltage at the non-inverting input of the first comparator U181 exceeds the reset threshold voltage  $V_{RST}$ . The output of the first comparator U181 is then driven high towards the supply voltage  $V_{CC}$  and the capacitor C190 conducts a pulse of current into the resistor R192, such that the magnitude of the voltage at the inverting input of the second comparator U191 exceeds the reset threshold voltage  $V_{RST}$ , and the second comparator pulls the timing voltage  $V_{TIM}$  down towards circuit common (i.e., the magnitude of the timing voltage is controlled from approximately 0.6 volts to zero volts). The magnitude of the voltage at the inverting input of the comparator U172 of the latch circuit 170 is now less than the latch threshold voltage  $V_{TH-L}$  (i.e., approximately 0.1 V), and the comparator stops pulling the timing voltage  $V_{TIM}$  down towards circuit common. In addition, the reset circuit 180 only drives the timing voltage  $V_{TIM}$  low for a brief period of time (e.g., approximately 68  $\mu$ sec) before the capacitor C190 fully charges and then stops conducting the pulse of current into the resistor R192. Accordingly, the second comparator U191 then stops pulling the timing voltage  $V_{TIM}$  down towards circuit common, thus

allowing the timing voltage to once again begin increasing in magnitude with respect to time at the constant rate.

**[0080]** After the reset circuit 180 resets the generation of the timing voltage  $V_{TIM}$  after the beginning of each half cycle, the comparator U172 of the latch circuit 170 stops pulling the timing voltage  $V_{TIM}$  down towards circuit common and the magnitude of the latch voltage  $V_{LATCH}$  is pulled high towards the supply voltage  $V_{CC}$  via the resistor R195 and the diode D196. At this time, the FET Q194 is rendered conductive, thus maintaining the inverting input of the second comparator U191 less than the reset threshold voltage  $V_{RST}$ . The FET Q194 is rendered non-conductive when the comparator U172 of the one-shot latch circuit 170 pulls the timing voltage  $V_{TIM}$  low near the end of the half cycle. Thus, the FET Q194 is rendered conductive for most of each half cycle and prevents the reset circuit 180 from resetting the generation of the timing voltage  $V_{TIM}$  until after the latch circuit 170 ceases the generation of the timing voltage, thereby greatly improving the noise immunity of the dimmer switch 100 with respect to impulse noise on the AC line voltage  $V_{AC}$ .

**[0081]** When the magnitude of the voltage at the non-inverting input of the first comparator U181 of the reset circuit 170 exceeds the reset threshold voltage  $V_{RST}$ , the output is then driven high towards the supply voltage  $V_{CC}$  and the capacitor C190 charges. The FET Q194 is then rendered conductive, and the capacitor C190 remains charged. When the magnitude of the rectified voltage  $V_{RECT}$  drops below the break-over voltage of the zener diode Z182 at the end of each half cycle and the magnitude of the voltage at the non-inverting input of the first comparator U181 drops below the reset threshold voltage  $V_{RST}$ , the capacitor C190 discharges through the diode D193 and the output of the first comparator U181. However, the magnitude of the voltage at the inverting input of the second comparator U191 remains less than the reset threshold voltage  $V_{RST}$ , and thus the reset circuit 180 does not reset the generation of the timing voltage  $V_{TIM}$  until the magnitude of the voltage at the non-inverting input of the first comparator U181 of the reset circuit 170 rises above the reset threshold voltage  $V_{RST}$  at the beginning of the next half cycle.

**[0082]** Accordingly, the control circuit 115 of the dimmer switch 100 of the first embodiment of the present invention conducts a control current through the LED driver 102 and provides constant gate drive to the bidirectional semiconductor switch 110 after the bidirectional semiconductor switch is rendered conductive. The control circuit 115 is operable to derive zero-crossing timing information from the voltage developed across the LED driver 102, and thus from the control current  $I_{CNTL}$  conducted through the LED driver 102. The average magnitude of the control current  $I_{CNTL}$  conducted through the LED driver 102 is approximately equal to the sum of the average magnitude of the timing current  $I_{TIM}$  and the drive current  $I_{DR}$ , as well as the other currents drawn by the timing circuit 130 and the trigger circuit 140. The control circuit 115 is operable to render the bidirectional semiconductor switch 110 conductive each half cycle in response to the variable threshold that is representative of the desired intensity of the LED light source 104 and to maintain the bidirectional semiconductor switch conductive until approximately the end of the present half cycle. As a result, the conduction time  $T_{CON}$  of the drive voltage  $V_{DR}$  generated by the trigger circuit 140 has a length

that is not dependent upon the length of the fixed amount of time  $T_{TIM}$  that the timing circuit 130 generates the timing signal  $V_{TIM}$ .

**[0083]** FIG. 6 is a simplified schematic diagram of a dimmer switch 200 according to a second embodiment of the present invention. FIG. 7 shows example waveforms illustrating the operation of the dimmer switch 200 according to the second embodiment of the present invention. The bidirectional semiconductor switch of the dimmer switch 200 of the second embodiment is implemented as two individual MOS-gated transistors, e.g., FETs Q210A, Q210B, coupled in anti-series connection between the hot terminal H and the dimmed hot terminal DH for control of the amount of power delivered to the LED driver 102. The sources of the FETs Q210A, Q210B are coupled together at circuit common. The FETs Q210A, Q210B may comprise metal-oxide semiconductor FETs (MOSFETs) or may alternatively be replaced by any suitable voltage-controlled semiconductor switches, such as, for example, insulated gate bipolar junction transistors (IGBTs). The FETs Q210A, Q210B have control inputs (i.e., gates) that are coupled to a gate coupling circuit 250, which comprises respective gate resistors R252, R254 (e.g., each having a resistance of approximately  $47\Omega$ ) for coupling to the gates of the FETs a drive voltage  $V_{DR-INV}$ . The drive voltage  $V_{DR-INV}$  as shown in FIG. 7 is the inverse of the drive voltage  $V_{DR}$  of the first embodiment. Each FET Q210A, Q210B is rendered conductive when the voltage at the gates of the FET is driven to a rated gate threshold voltage (e.g., approximately 10 volts). The FETs Q210A, Q210B are simultaneously controlled to be conductive and non-conductive using the forward phase-control technique, and are operable to be rendered conductive and to remain conductive independent of the magnitude of the load current  $I_{LOAD}$  conducted through the FETs.

**[0084]** The dimmer switch 200 comprises a full-wave rectifier bridge that includes the body diodes of the two FETs Q210A, Q210B in addition to two diodes D214A, D214B. The timing circuit 130 of the dimmer switch 200 of the second embodiment operates in the same manner as in the first embodiment. The dimmer switch 200 comprises an analog control circuit 215 having a variable-threshold trigger circuit 240 that is similar to the variable-threshold trigger circuit 140 of the first embodiment. However, the trigger circuit 240 of the second embodiment comprises a comparator U242 having a non-inverting input that receives the timing voltage  $V_{TIM}$  and an inverting input that receives a variable threshold voltage  $V_{TH}$  from a potentiometer R244. The trigger circuit 240 operates to drive the drive voltage  $V_{DR-INV}$  high towards the supply voltage  $V_{CC}$  to render the FETs Q210A, Q210B conductive, and low towards circuit common to render the FETs non-conductive (as shown in FIG. 7).

**[0085]** As shown in FIG. 7, the gates of the FETs Q210A, Q210B only conduct a small pulse of drive current  $I_{DR-INV}$  from the power supply 120 when the FETs Q210A, Q210B are rendered conductive, i.e., due to the charging of the input capacitances of the gates of the FETs (which each may have, for example, an input capacitance of approximately  $100\mu F$ ). Since the drive current  $I_{DR-INV}$  is conducted from the storage capacitor C128 of the power supply 120, the average magnitude of the control current  $I_{CNTL}$  conducted through the LED driver 102 by the analog control circuit 215 of the dimmer switch 200 of the second embodiment is less than the average magnitude of the control current  $I_{CNTL}$  con-

ducted by the analog control circuit 115 of the dimmer switch 100 of the first embodiment (which conducts the drive current  $I_{DR}$  through the input photodiode of the opto-coupler U152 for the entire time that the triac 110' is rendered conductive).

**[0086]** In addition, the dimmer switch 200 of the second embodiment does not require the opto-coupler U152 of the first embodiment, which is typically expensive and is also characterized by a rated turn-on time (e.g., approximately 35 microseconds). In the event that the load current LOAD changes direction after the triac 110' is rendered conductive, the rated turn-on time of the opto-coupler U152 limits how quickly the triac 110' can be rendered conductive after becoming non-conductive. Specifically, during the time from when the triac 110' becomes momentarily non-conductive and is once again rendered conductive, the magnitude of the phase-control voltage  $V_{PC}$  across the LED driver 102 decreases while the magnitude of the voltage across the dimmer switch 100 increases. This change in the voltage across the input of the LED driver 102 (or electronic ballast) may result in fluctuations in the intensity of the LED light source 104 (or fluorescent lamp) for some high-efficiency lighting loads. Because the bidirectional semiconductor switch of the dimmer switch 200 is implemented as FETs Q210A, Q210B and because the FETs Q210A, Q210B are operable to remain conductive independent of the magnitude of the load current, potential fluctuations in the intensity of some high-efficiency lighting loads are avoided.

**[0087]** FIG. 8 is a simplified schematic diagram of a dimmer switch 300 according to a third embodiment of the present invention. The dimmer switch 300 of the third embodiment comprises the triac 110' (as in the first embodiment). However, the dimmer switch 300 includes a gate coupling circuit 350 that comprises a voltage-controlled controllably conductive device, such as two MOS-gated transistors (e.g., FETs Q352A, Q352B) coupled in anti-series connection between the gate and a first one of the main load terminals of the triac 110' (e.g., the hot terminal H of the dimmer switch). The FETs Q352A, Q352B may comprise MOSFETs or may alternatively be replaced by any suitable voltage-controlled semiconductor switches, such as, for example, IGBTs. The sources of the FETs Q352A, Q352B are coupled together through two source resistors R353, R354 (e.g., each having a resistance of approximately  $10\Omega$ ), where the junction of the two resistors R353, R354 is coupled to circuit common. The source resistors R353, R354 operate to limit the magnitude of the gate current  $I_G$  conducted through the gate of the triac 110' to a maximum gate current (e.g., approximately 0.6 amp). The gates of the FETs Q352A, Q352B are coupled to respective gate resistors R355, R356 (e.g., each having a resistance of approximately  $47\Omega$ ). The drive voltage  $V_{DR-INV}$  generated by the analog control circuit 215 is received at a control input of the gate coupling circuit 350 (i.e., the junction of the gate resistors R355, R356).

**[0088]** The dimmer switch 300 comprises a resistor R358, which has a resistance of, for example, approximately  $30.9\Omega$  and is coupled between the gate and a second one of the main load terminals of the triac 110' (e.g., to the dimmed hot terminal DH of the dimmer switch). The dimmer switch 300 further comprises a full-wave rectifier bridge that includes the body diodes of the FETs Q352A, Q352B and the diodes D214A, D214B, and generates the rectified voltage  $V_{RECT}$  that is received by the power supply 120 and the timing



circuit **130** of the control circuit **215**. Accordingly, the control circuit **215** is coupled to the first main load terminal of the triac **110'** through the body diode of the FET **Q352A** and the diode **D214A**, and to the second main load terminal of the triac through the body diode of the FET **Q352B**, the diode **D214B**, and the resistor **R358**. Alternatively, the control circuit **215** could be directly coupled to at least one of the main load terminals of the triac **110'**, or electrically coupled to at least one of the main load terminals of the triac through one or more resistors.

**[0089]** The timing circuit **130** of the control circuit **215** generates the timing voltage  $V_{TIM}$  and the variable-threshold trigger circuit **240** generates the drive voltage  $V_{DR-INV}$  as in the second embodiment (as shown in FIG. 7). When the drive voltage  $V_{DR-INV}$  is driven low towards circuit common, the FETs **Q352A**, **Q352B** are non-conductive, such that the triac **110'** is also non-conductive. When the trigger circuit **240** drives the drive voltage  $V_{DR-INV}$  high towards the supply voltage  $V_{CC}$  at the firing time each half cycle, the FETs **Q352A**, **Q352B** are able to conduct the gate current  $I_G$  through the gate of the triac **110'** to render the triac conductive. The drive voltage  $V_{DR-INV}$  is driven low slightly before the end of the half cycle, such that the blanking pulse exists at the end of the half cycle to allow the triac **110'** to commutate off. Since the drive voltage  $V_{DR-INV}$  remains high until approximately the end of the half-cycle, the FETs **Q352A**, **Q352B** remain conductive such that the FETs **Q352A**, **Q352B** are able to conduct the gate current  $I_G$  at any time from the firing time through approximately the remainder of the half cycle. Accordingly, the triac **110'** is rendered conductive from the firing time to approximately the end of the half cycle, thereby allowing the load current  $I_{LOAD}$  to be either polarity (i.e., positive or negative) in any given half cycle, which is particularly important when the LED driver **102** has a capacitive impedance and causes the load current to change polarity before one of the zero-crossings.

**[0090]** The control input of the gate coupling circuit **350** only conducts the small pulses of drive current  $I_{DR-INV}$  from the power supply **120** when the FETs **Q352A**, **Q352B** are rendered conductive due to the charging of the input capacitances of the gates of the FETs (i.e., as shown in FIG. 7). Thus, the gate coupling circuit **350** allows the analog control circuit **215** to render the triac **110'** conductive and maintain the triac conductive without the need to conduct the drive current  $I_{DR-INV}$  through the control input of the gate coupling circuit during approximately the remainder of the half cycle (e.g., in contrast to the input photodiode of the optocoupler **U152** of the first embodiment conducting the drive current  $I_{DR}$  as shown in FIGS. 3A and 3B). Accordingly, the average magnitude of the control current  $I_{CNTL}$  conducted by the analog control circuit **215** of the dimmer switch **300** of the third embodiment to render the triac **110'** conductive is less than the average magnitude of the control current  $I_{CNTL}$  conducted by the analog control circuit **115** of the dimmer switch **100** of the first embodiment to render the triac **110'** conductive. For example, if the FETs **Q352A**, **Q352B** are each characterized by a turn-on time of approximately two microseconds, an input impedance of approximately 100  $\mu$ F, and a gate threshold voltage of approximately 10 volts, the gate coupling circuit **350** may conduct an average current of approximately 240 nanoamps from the storage capacitor **C128** of the power supply **120** (independent of the target intensity  $L_{TRGT}$  of the LED light source **104**).

**[0091]** In addition, the dimmer switch **300** of the third embodiment does not require the opto-coupler **U152** to render the triac **110'** conductive. As previously mentioned, the opto-coupler **U152** is typically expensive and is characterized by the rated turn-on time, which limits how quickly the triac **110'** can be rendered conductive after becoming non-conductive in response to the load current  $I_{LOAD}$  changing directions.

**[0092]** Since the magnitude of the gate current  $I_G$  conducted by the FETs **Q352A**, **Q352B** of the gate coupling circuit **350** is much less than the magnitude of the load current  $I_{LOAD}$  conducted by the triac **110'**, the FETs **Q352A**, **Q352B** of the third embodiment may be sized smaller in power rating (and accordingly, in physical size) than the FETs **Q210A**, **Q210B** of the dimmer switch **200** of the second embodiment (which conduct the load current  $I_{LOAD}$ ). In other words, because the FETs **Q352A**, **Q352B** of the third embodiment do not conduct the load current  $I_{LOAD}$ , the FETs need not be power devices, but can rather be signal-level devices. Therefore, the dimmer switch **300** of the third embodiment only requires one power device (i.e., the triac **110'**) rather than two power devices (i.e., the FETs **Q210A**, **Q210B**), which leads to lower total cost of the dimmer switch **300**, as well as fewer constraints to physically fit and heat sink two power devices in a single wall-mounted load control device. In addition, the triac **110'** typically has better peak current capabilities in a single package as compared to the two FETs **Q210A**, **Q210B** having similar sized packages.

**[0093]** Accordingly, the triac **110'** and the gate coupling circuit **350** of the dimmer switch **300** of the third embodiment provide a thyristor-based load control circuit that requires substantially no net average current to be conducted through the control input after the triac is rendered conductive through the remainder of the half-cycle using a constant gate drive signal. As used herein, “substantially no net average current” is defined as an amount of current appropriate to charge the input capacitances of the gates of the FETs **Q352A**, **Q352B** (or other suitable switching devices) of the gate coupling circuit **350**, for example, less than approximately one microamp.

**[0094]** FIG. 9 is a simplified block diagram of a reverse-phase control dimmer switch **400** according to a fourth embodiment of the present invention. As shown in FIG. 9, the bidirectional semiconductor switch **110** is implemented as two FETs **Q210A**, **Q210B** coupled in anti-series connection (as in the second embodiment). The dimmer switch **100** comprises an analog control circuit including a voltage reference circuit **420**, a timing circuit **430**, and a gate drive circuit **440**. The voltage reference circuit **420** includes a pass-transistor circuit **460** and a snap-on circuit **470**, and operates to generate a reference voltage  $V_{REF}$  (e.g., approximately 14.4 volts) from the rectified voltage  $V_{RECT}$ . The timing circuit **430** receives the reference voltage  $V_{REF}$  and generates a timing voltage  $V_{TIM}$ , which is representative of the target intensity  $L_{TRGT}$  of the LED light source **104**. The gate drive circuit **440** generates a gate voltage  $V_G$ , which is coupled to the gates of the FETs **Q210A**, **Q210B** via the gate coupling circuit **250** for simultaneously rendering the FETs conductive and non-conductive. According to the fourth embodiment of the present invention, the phase-control voltage  $V_{PC}$  generated by the dimmer switch **400** comprises a reverse phase-control voltage. Accordingly, the gate drive circuit **440** operates to render the FETs **Q210A**, **Q210B**

conductive at the beginning of each half cycle, and non-conductive at some time during each half cycle in response to the timing voltage  $V_{TIM}$ .

[0095] FIG. 10 is a simplified timing diagram showing examples of the phase-control voltage  $V_{PC}$  generated by the dimmer switch 400, the timing voltage  $V_{TIM}$ , and the gate voltage  $V_G$  for driving the FETs Q210A, Q210B according to the fourth embodiment of the present invention. The phase-control voltage  $V_{PC}$  has a magnitude equal to approximately the magnitude of the AC line voltage  $V_{AC}$  of the AC power source 105 at the beginning of each half cycle during a conduction time  $T_{CON}$ , and has a magnitude of approximately zero volts during the rest of the half cycle, i.e., during a non-conduction time  $T_{NC}$ . To generate the phase-control voltage  $V_{PC}$ , the gate drive circuit 440 drives the gate voltage  $V_G$  high towards the reference voltage  $V_{REF}$  at the beginning of each half cycle, such that the FETs Q210A, Q210B are rendered conductive (as shown at time  $t_1$  in FIG. 10). At this time, the timing circuit 430 begins generating the timing voltage  $V_{TIM}$  which comprises a ramp voltage that increases in magnitude with respect to time at a rate representative of the target intensity  $L_{TRGT}$  of the LED light source 104 (i.e., in response to the intensity adjustment actuator 118). When the magnitude of the timing voltage  $V_{TIM}$  reaches a maximum timing voltage threshold  $V_{T-MAX}$  (e.g., approximately 7.5 volts), the gate drive circuit 440 renders the FETs Q210A, Q210B non-conductive (as shown at time  $t_2$  in FIG. 10). The rate of the timing voltage  $V_{TIM}$  is inversely proportional to the target intensity  $L_{TRGT}$ , i.e., the rate of the timing voltage  $V_{TIM}$  increases as the target intensity  $L_{TRGT}$  decreases, and decreases as the target intensity  $L_{TRGT}$  increases. After the FETs Q210A, Q210B are rendered non-conductive, the gate drive circuit 440 will render the FETs conductive once again at the beginning of the next half cycle (as shown at time  $t_3$  in FIG. 10).

[0096] FIG. 11 is a simplified schematic diagram of the dimmer switch 400 according to the fourth embodiment of the present invention. As shown in FIG. 11, the pass-transistor circuit 460 comprises an NPN bipolar junction transistor Q462 having a collector coupled to receive the rectifier voltage  $V_{RECT}$  through a resistor R464 (e.g., having a resistance of approximately 180 $\Omega$ ). The base of the transistor Q462 is coupled to the rectifier voltage  $V_{RECT}$  through a resistor R465 (e.g., having a resistance of approximately 470 k $\Omega$ ), and to circuit common through a zener diode Z466 (e.g., having a break-over voltage of approximately 15 volts). The pass-transistor circuit 460 further comprises a storage capacitor C468, which is able to charge through the transistor Q462 and a diode D469 to a voltage equal to approximately the break-over voltage of the zener diode Z466 minus the base-emitter drop of the transistor Q462 and the forward drop of the diode D469. The storage capacitor C468 has, for example, a capacitance of approximately 22  $\mu$ F, and operates to maintain the reference voltage  $V_{REF}$  at an appropriate magnitude (e.g., at least approximately 12 volts) to control the FETs Q210A, Q210B to be conductive (i.e., when there is approximately zero volts generated across the dimmer switch 100) as will be described in greater detail below.

[0097] The snap-on circuit 470 is coupled to the storage capacitor Q468 and comprises a PNP bipolar junction transistor Q472. The base of the transistor Q472 is coupled to circuit common through the series combination of a resistor R474 (e.g., having a resistance of approximately 22 k $\Omega$ ) and

a zener diode Z476 (e.g., having a break-over voltage of approximately 12 volts). The reference voltage  $V_{REF}$  is generated across a capacitor C478, which is coupled between the collector of the transistor Q472 and circuit common and has, for example, a capacitance of approximately 0.1  $\mu$ F. The snap-on circuit 470 operates such that the reference voltage  $V_{REF}$  is only provided across the capacitor C478 when the magnitude of the voltage across the storage capacitor C468 of the pass-transistor circuit 460 exceeds the break-over voltage of the zener diode Z476 plus the emitter-base drop of the transistor Q472.

[0098] The timing circuit 430 receives the reference voltage  $V_{REF}$  and generates the timing voltage  $V_{TIM}$  across a timing capacitor C432 (e.g., having a capacitance of approximately 10 nF). The timing circuit 430 includes a constant current source circuit for charging the capacitor C432 at a constant rate to generate the timing voltage  $V_{TIM}$ . The constant current source circuit comprises a PNP bipolar junction transistor Q434 having an emitter coupled to the reference voltage  $V_{REF}$  via a resistor R435 (e.g. having a resistance of approximately 180 k $\Omega$ ). A voltage divider circuit comprising a potentiometer R436 and two resistors R438, R439 is coupled between the reference voltage  $V_{REF}$  and circuit common. For example, the potentiometer R436 may have a resistance ranging from approximately 0 to 500 k $\Omega$ , while the resistors R438, R439 may have resistances of approximately 100 k $\Omega$  and 82 k $\Omega$ , respectively. The junction of the potentiometer R436 and the resistor R438 is coupled to the base of the transistor Q434. The resistance of the potentiometer R436 varies in response to the intensity adjustment actuator 118 of the dimmer switch 100, such that the magnitude of the voltage at the base of the transistor Q434 is representative of the target intensity  $L_{TRGT}$ . When the potentiometer R436 is not presently being adjusted (i.e., is in a steady state condition), a constant voltage is generated across the resistor R435 and the emitter-base junction of the transistor Q434, such that the transistor Q434 conducts a constant current (having a magnitude dependent upon the magnitude of the voltage at the base of the transistor Q434). Accordingly, the capacitor C432 charges at a rate dependent upon the target intensity  $L_{TRGT}$  thus generating the timing voltage  $V_{TIM}$  (as shown in FIG. 10).

[0099] The gate drive circuit 440 renders the FETs Q210A, Q210B conductive at the beginning of each half cycle, and non-conductive at some time during each half cycle in response to the timing voltage  $V_{TIM}$  from the timing circuit 430. The gate drive circuit 440 comprises an NPN bipolar junction transistor Q441 and a resistor R442, which is coupled between the collector and base of the transistor Q441 and has a resistance of, for example, approximately 270 k $\Omega$ . A diode D443 is coupled between the emitter and the base of the transistor Q441. At the beginning of each half cycle, the resistor R442 conducts current into the base of the transistor Q441. The transistor Q441 is thus rendered conductive and the reference voltage  $V_{REF}$  is coupled to the gates of the FETs Q210A, Q210B via the respective gate resistors R252, R254 to thus render the FETs conductive. As previously mentioned, the storage capacitor C468 of the voltage reference circuit 420 maintains the reference voltage  $V_{REF}$  at an appropriate magnitude (i.e., at least approximately 14.4 volts) to maintain the FETs Q210A, Q210B conductive and the voltage developed across the dimmer switch 400 is approximately zero volts.

[0100] The timing voltage  $V_{TIM}$  is coupled to the base of an NPN bipolar junction transistor Q444 through a zener diode Z445 (e.g., having a break-over voltage of approximately 6.8 volts). When the magnitude of the timing voltage  $V_{TIM}$  exceeds approximately the break-over voltage of the zener diode Z445 plus the base-emitter drop of the transistor Q444 (i.e., the maximum timing voltage threshold  $V_{T-MAX}$ ), the transistor Q444 is rendered conductive. Accordingly, the gate voltage  $V_G$  is pulled down towards circuit common through the diode D443 thus rendering the FETs Q210A, Q210B non-conductive.

[0101] The gate drive circuit 440 also comprises an NPN bipolar junction transistor Q446 coupled across the zener diode Z445. The base of the transistor Q446 is coupled to the junction of two series-connected resistors R447, R448 (e.g., having resistances of approximately 200 k $\Omega$  and 10 k $\Omega$  respectively). The resistors R447, R448 form a voltage divider coupled between the rectified voltage  $V_{RECT}$  and circuit common. The base of the transistor Q446 is also coupled to circuit common via a capacitor C449 (e.g., having a capacitance of approximately 10 nF). When the FETs Q210A, Q210B are rendered non-conductive (in response to the timing voltage  $V_{TIM}$  exceeding the maximum timing voltage threshold  $V_{T-MAX}$ ), the voltage developed across the dimmer switch 400 increases to approximately the magnitude of the AC line voltage  $V_{AC}$  of the AC power source 105. As a result, the voltage at the base of the transistor Q446 increases such that the transistor is rendered conductive. Accordingly, the magnitude of the timing voltage  $V_{TIM}$  is controlled to approximately zero volts and the transistor Q444 is maintained conductive (thus keeping the FETs Q210A, Q210B non-conductive) until the end of the present half cycle.

[0102] Near the end of the half cycle, the magnitude of the AC line voltage  $V_{AC}$  of the AC power source 105 as well as the magnitude of voltage at the base of the transistor Q446 decrease such that the transistor Q446 is rendered non-conductive. Accordingly, the transistor Q444 is rendered non-conductive and the reference voltage  $V_{REF}$  is coupled to the gates of the FETs Q210A, Q210B through the transistor Q441 and the respective gate resistors R252, R254, thus rendering the FETs conductive. In addition, when the transistor Q446 is non-conductive, the timing voltage  $V_{TIM}$  of the timing circuit 430 may once again begin increasing in magnitude with respect to time at the rate dependent upon the target intensity  $L_{TRGT}$  (as shown in FIG. 10).

[0103] FIG. 12 is a simplified schematic diagram of a dimmer switch 480 according to an alternate embodiment of the present invention. The dimmer switch 480 of FIG. 12 is very similar to the dimmer switch 400 of the fourth embodiment. However, the dimmer switch 480 of FIG. 12 comprises a voltage compensation circuit 490, which receives the rectified voltage  $V_{RECT}$  and adjusts the timing voltage  $V_{TIM}$  to account for changes and fluctuations in the AC line voltage  $V_{AC}$  of the AC power source 105 to avoid flickering of the intensity of the LED light source 104. The voltage compensation circuit 490 comprises two resistors R492, R494, which are coupled in series between the rectified voltage  $V_{RECT}$  and circuit common, and have, for example, resistances of approximately 1 M $\Omega$  and 98 k $\Omega$ , respectively. A capacitor C496 is coupled between the junction of the resistors R492, R494 and circuit common, and has, for example, a capacitance of approximately 0.22  $\mu$ F. The

capacitor C496 is coupled to the timing voltage  $V_{TIM}$  through a resistor R498 (e.g., having a resistance of approximately 560 k $\Omega$ ).

[0104] The voltage produced across the capacitor C496 is proportional to the magnitude of the AC line voltage  $V_{AC}$  of the AC power source 105 when the FETs Q210A, Q210B are non-conductive and the timing voltage  $V_{TIM}$  is increasing in magnitude with respect to time. When there are no changes or fluctuations in the magnitude of the AC line voltage  $V_{AC}$  of the AC power source 105, the capacitor C496 charges to a steady-state voltage. However, if the magnitude of the AC line voltage  $V_{AC}$  changes while the FETs Q210A, Q210B are non-conductive during a half cycle (e.g., between times  $t_2$  and  $t_3$  in FIG. 10), the magnitude of the voltage across the capacitor C496 will also change, thus resulting in a change in the timing voltage  $V_{TIM}$  when the FETs are conductive during the next half cycle (e.g., between times  $t_3$  and  $t_4$ ). For example, if the magnitude of the AC line voltage  $V_{AC}$  (and thus the magnitude of the voltage across the capacitor C496) increases while the FETs Q210A, Q210B are non-conductive during a half cycle, the magnitude of the timing voltage  $V_{TIM}$  will be greater while the FETs are conductive during the next half cycle, thus causing the FETs to be rendered non-conductive earlier in the next half cycle.

[0105] FIG. 13 is a simplified schematic diagram of a dimmer switch 500 according to a fifth embodiment of the present invention. The dimmer switch 500 comprises a mechanical air-gap switch S514 and two FETs Q510A, Q510B coupled in anti-series connection between the hot terminal H and the dimmed hot terminal DH for generating the phase-control voltage  $V_{PC}$ . The dimmer switch 500 comprises an analog control circuit (e.g., a timing circuit 520) for generating a timing voltage  $V_{TIM}$  representative of the target intensity  $L_{TRGT}$  of the LED light source 104, and a gate drive circuit 530 for rendering the FETs Q510A, Q510B conductive and non-conductive in response to the timing voltage  $V_{TIM}$  to thus generate the phase-control voltage  $V_{PC}$ . According to the fifth embodiment of the present invention, the gate drive circuit 530 is operable to generate two gate voltages  $V_{G1}$ ,  $V_{G2}$  for independently controlling the respective FETs Q510A, Q510B on a complementary basis. The FETs Q510A, Q510B are rendered conductive when the magnitudes of the respective gate voltages  $V_{G1}$ ,  $V_{G2}$  are controlled to a nominal gate voltage  $V_N$  (e.g., approximately 9 V) and are rendered non-conductive when the magnitudes of the respective gate voltages  $V_{G1}$ ,  $V_{G2}$  are controlled to approximately zero volts. The dimmer switch 500 further comprises an overcurrent protection circuit 540 for rendering the FETs Q510A, Q510B non-conductive in the event of an overcurrent condition in the FETs.

[0106] FIG. 14 is a simplified timing diagram showing examples of the phase-control voltage  $V_{PC}$  generated by the dimmer switch 500 and the gate voltages  $V_{G1}$ ,  $V_{G2}$  for driving the FETs Q510A, Q510B, respectively. According to the fifth embodiment of the present invention, the phase-control voltage  $V_{PC}$  comprises a forward phase-control voltage. During the positive half cycles, the first FET Q510A is rendered conductive and the second FET Q510B is rendered non-conductive when the first gate voltage  $V_{G1}$  increases from approximately zero volts to the nominal gate voltage  $V_N$  (as shown at time  $t_1$ ), and the second gate voltage  $V_{G2}$  decreases from the nominal gate voltage  $V_N$  to approximately zero volts. At this time, the dimmer switch 500

conducts the load current  $I_{LOAD}$  to the LED driver **102** through the first FET **Q510A** and the body diode of the second FET **Q510B**. At the beginning of the negative half cycles, the first FET **Q510** remains conductive. However, since the second FET **Q510B** is non-conductive and the body diode of the second FET **Q510B** is reversed-biased, the dimmer switch **500** does not conduct the load current  $I_{LOAD}$  at this time.

**[0107]** During the negative half cycles, the first FET **Q510A** is rendered non-conductive and the second FET **Q510B** is rendered conductive when the first gate voltage  $V_{G1}$  decreases from the nominal gate voltage  $V_N$  to approximately zero volts and the second gate voltage  $V_{G2}$  increases from approximately zero volts to the nominal gate voltage  $V_N$  (as shown at time  $t_2$ ). At this time, the dimmer switch **500** conducts the load current  $I_{LOAD}$  to the LED driver **102** through the second FET **Q510B** and the body diode of the first FET **Q510A**. At the beginning of the positive half cycles, the second FET **Q510B** remains conductive, the first FET **Q510A** remains non-conductive, and the body diode of the first FET **Q510A** is reversed-biased at this time, such that the dimmer switch **500** does not conduct the load current  $I_{LOAD}$  until the first FET **Q510A** is rendered conductive.

**[0108]** The timing circuit **520** is coupled in series between the hot terminal H and the dimmed hot terminal DH and conducts a timing current  $I_{TIM}$  (i.e., a control current) through the LED driver **102** in order to generate the timing voltage  $V_{TIM}$  across a capacitor **C522** (e.g., having a capacitance of approximately 0.1  $\mu$ F). The capacitor **C522** is operable to charge from the AC power source **105** through resistors **R524**, **R525** (e.g., having resistances of approximately 27 k $\Omega$  and 10 k $\Omega$ , respectively) and a potentiometer **R526**. The resistance of the potentiometer **R526** may range from, for example, approximately 0 k $\Omega$  to 300 k $\Omega$ , and may be controlled by a user of the dimmer switch **500** (e.g., by actuating the slider control) to adjust the target intensity  $L_{TRGT}$  of the LED light source **104**. A calibration resistor **R527** is coupled to potentiometer **R526** for calibrating the range of the potentiometer, and has a resistance of, for example, approximately 300 k $\Omega$ . Since the capacitor **C522** charges through the potentiometer **R526**, the rate at which the capacitor **C522** charges and thus the magnitude of the timing voltage  $V_{TIM}$  are representative of the target intensity  $L_{TRGT}$  of the LED light source **104**.

**[0109]** The drive circuit **530** comprises a diac **532** (e.g., having a break-over voltage  $V_{BR}$  of approximately 32 volts) and two pulse transformers **534A**, **534B**. The diac **532** is coupled in series with the primary windings of the two pulse transformers **534A**, **534B**. The secondary windings of the pulse transformers **534A**, **534B** are coupled to respective capacitors **C535A**, **C535B** via respective zener diodes **Z536A**, **Z536B** (which each have a break-over voltage approximately equal to the nominal gate voltage  $V_N$ , i.e., approximately 9 V). The capacitors **C535A**, **C535B** are coupled to the gates of the FETs **Q510A**, **Q510B** via gate resistors **R538A**, **R538B**, respectively (e.g., having resistances of approximately 47 k $\Omega$ ). The gate resistors **R538A**, **R538B** may alternatively have different resistances in order to change the duration of the switching times of the FETs **Q510A**, **Q510B** as is well known in the art.

**[0110]** When the magnitude of the timing voltage  $V_{TIM}$  exceeds approximately the break-over voltage  $V_{BR}$  of the diac **532**, the diac conducts a pulse of current (i.e., a firing current  $I_{FIRE}$  as shown in FIG. 13) through the primary

windings of the pulse transformers **534A**, **534B** causing secondary voltages  $V_{SEC}$  (e.g., approximately 9V) to be generated across the secondary windings of the pulse transformers. During the positive half cycles, the capacitor **C535A** charges from the secondary winding of the first pulse transformer **534A** through the zener diode **Z536A** to approximately the nominal gate voltage  $V_N$  (i.e., approximately 9 volts). Accordingly, the first gate voltage  $V_{G1}$  is driven high from approximately zero volts to the nominal gate voltage  $V_N$  rendering the first FET **Q510A** conductive (as shown at time  $t_1$  in FIG. 14). At the beginning of the negative half cycles, the first FET **Q510A** is conductive, while the second FET **Q510B** is non-conductive. Since the body diode of the second FET **Q510B** is reversed biased at this time, the dimmer switch **500** does not conduct the load current  $I_{LOAD}$ .

**[0111]** During the negative half cycles, the firing current  $I_{FIRE}$  has a negative magnitude, thus causing the secondary voltages  $V_{SEC}$  across the secondary windings of the pulse transformers **534A**, **534B** to also have negative magnitudes. Accordingly, the zener diode **Z536A** is reverse-biased during the negative half cycles, causing the capacitor **C535A** to discharge through the zener diode **Z536A**, such that the voltage across the capacitor **C535A** is driven to approximately zero volts. As a result, the first gate voltage  $V_{G1}$  is driven low from the nominal gate voltage  $V_N$  to approximately zero volts rendering the first FET **Q510A** non-conductive (as shown at time  $t_2$  in FIG. 14). In addition, the zener diode **Z536B** coupled to the secondary winding of the second pulse transformer **534B** is forward-biased in the negative half cycles, such that the capacitor **C535B** charges to approximately the nominal gate voltage  $V_N$  and the second FET **Q510B** is rendered conductive during the negative half cycles (as shown at time  $t_2$  in FIG. 14). Accordingly, the FETs **Q510A**, **Q510B** are driven in a complementary manner, such that—at all times—at least one FET is conductive, while the other FET is non-conductive. As a result, the FETs **Q510A**, **Q510B** are driven to be conductive for approximately the period  $T_{HC}$  of a half cycle and non-conductive for the period  $T_{HC}$  of a half cycle.

**[0112]** The timing circuit **520** also comprises a diac **528** (e.g., having a break-over voltage of approximately 64V) coupled to the potentiometer **R526**. The diac **528** provides voltage compensation by adjusting the voltage provided to the potentiometer **R526** to compensate for variations in the AC line voltage  $V_{AC}$  provided by the AC power source **105**. The diac **528** has a negative impedance transfer function, such that the voltage across the diac increases as the current through the diac decreases. Thus, as the voltage across the dimmer switch **500** (i.e., between the hot terminal H and the dimmed hot terminal DH) decreases, the current through the resistor **R524** and the diac **528** decreases. As a result, the voltage across the diac **528** increases, thus causing the current flowing through the potentiometer **R526** to increase and the firing capacitor **C522** to charge at a faster rate. This results in an increased conduction time  $T_{CON}$  of the FETs **Q510A**, **Q510B** during the present half cycle to compensate for the decreased voltage across the dimmer switch **500**, thereby maintaining the intensity of the LED light source **104** constant.

**[0113]** The drive circuit **530** is characterized as having inherent shorted-FET protection. In the event that one of the FETs **Q510A**, **Q510B** fails shorted, the drive circuit **530** is operable to drive the other, non-shortened FET into full

conduction, such that the load current  $I_{LOAD}$  is not asymmetric. Asymmetric current can cause some types of lighting loads to overheat. For example, if the second FET Q510B fails shorted, the full AC waveform will be provided to the LED driver 102 during the negative half cycles. Since there will be approximately zero volts produced across the dimmer switch 500 during the negative half cycles when second FET Q510B is shorted, the capacitor C522 of the timing circuit 520 will not charge, the diac 532 of the drive circuit 330 will not conduct the pulse of the firing current  $I_{FIRE}$ , and the voltage across the capacitor C535A will not be driven to zero volts to render the first FET Q510A non-conductive during the negative half cycles. Accordingly, the first FET Q510A will remain conductive during both half cycles and the load current  $I_{LOAD}$  will be substantially symmetric. The second FET Q510B is controlled to be conductive in a similar manner if the first FET Q510A has failed shorted.

[0114] The overcurrent protection circuit 540 comprises a sense resistor R542 (e.g., having a resistance of approximately 0.015 $\Omega$ ). The sense resistor R542 is coupled between the sources of the FETs Q510A, Q510B, such that a voltage representative of the magnitude of the load current LOAD is generated across the sense resistor. The voltage generated across the sense resistor R542 is provided to the base of a first NPN bipolar junction transistor (BJT) Q544. The first transistor Q544 is coupled across the capacitor C535A and operates to protect the first FET Q510A in the event of an overcurrent condition during the positive half cycles. When the magnitude of the load current LOAD exceeds a predetermined current limit (e.g., approximately 46.6 amps) such that the voltage generated across the sense resistor R542 exceeds the rated base-emitter voltage (e.g., approximately 0.7 volts) of the first transistor Q544, the first transistor is rendered conductive. Accordingly, the first transistor Q544 pulls the first gate voltage  $V_{G1}$  at the gate of the first FET Q510A down towards zero volts, thus rendering the first FET non-conductive. The overcurrent protection circuit 540 further comprises a second NPN bipolar junction transistor Q546, which is coupled across the capacitor C535B and operates to protect the second FET Q510B during the negative half cycles. When the magnitude of the load current  $I_{LOAD}$  exceeds the predetermined current limit, the second transistor Q546 is rendered conductive, thus pulling the second gate voltage  $V_{G2}$  at the gate of the second FET Q510B down towards zero volts and rendering the second FET non-conductive.

[0115] FIG. 15 is a simplified schematic diagram of a dimmer switch 600 according to a sixth embodiment of the present invention. The dimmer switch 600 comprises a drive limit circuit 650, which is coupled in series with the diac 532 and the primary windings of the two pulse transformers 534A, 534B of the drive circuit 530. The drive limit circuit 650 operates to limit the number of times that the drive circuit 530 attempts to render the FETs Q510A, Q510B conductive during a specific half cycle. For example, if the overcurrent protection circuit 540 renders one of the FETs Q510A, Q510B non-conductive, the drive limit circuit 650 prevents the drive circuit 530 from attempting to render the respective FET conductive again during the present half cycle.

[0116] When the diac 532 fires each half cycle, the drive limit circuit 650 conducts the firing current  $I_{FIRE}$  and generates an offset voltage  $V_{OFFSET}$  across a capacitor C652A during the positive half cycles and a capacitor C652B during

the negative half cycles. The capacitor C452A charges through a diode D654A during the positive half cycles, and the capacitor C452B charges through a diode D654B during the negative half cycles. For example, the capacitors C652A, C652B may have capacitances of approximately 0.1  $\mu$ F. Discharge resistors R656A, R656B are coupled in parallel with the capacitors C652A, C652B, respectively, and each have a resistance of, for example, approximately 33 k $\Omega$ . The drive limit circuit 450 further comprises two zener diodes Z658A, Z658B coupled in anti-series connection and each having the same break-over voltage  $V_Z$  (e.g., approximately 40V). The zener diodes Z658A, Z658B are coupled to the timing circuit 520 to limit the magnitude of the timing voltage  $V_{TIM}$  to a clamp voltage  $V_{CLAMP}$ , i.e., approximately the break-over voltage  $V_Z$  in both half cycles.

[0117] At the beginning of a positive half cycle, the capacitor C652A of the drive limit circuit 540 has no charge, and thus, no voltage is developed across the capacitor. The timing voltage signal  $V_{TIM}$  increases until the magnitude of the timing voltage  $V_{TIM}$  exceeds approximately the break-over voltage  $V_{BR}$  of the diac 532. When the diac 532 fires, the diode D654A and the capacitor C652A conduct pulse of the firing current  $I_{FIRE}$  and the offset voltage  $V_{OFFSET}$  (e.g., approximately 12 volts) is developed across the capacitor C652A. After the diac 532 has finished conducting the firing current  $I_{FIRE}$ , the voltage across the capacitor C522 decreases by approximately a break-back voltage (e.g., approximately 10 volts) of the diac 532 to a predetermined voltage VP (e.g., approximately 22 volts). If the overcurrent protection circuit 540 renders one of the FETs Q510A, Q510B non-conductive, the timing voltage signal  $V_{TIM}$  will begin to increase again. The magnitude of the timing voltage  $V_{TIM}$  must exceed approximately the break-over voltage  $V_{BR}$  of the diac 532 plus the offset voltage  $V_{OFFSET}$  across the capacitor C652A (i.e., approximately 44 volts) in order for the diac 532 to conduct the pulse of the firing current  $I_{FIRE}$  once again. However, because the zener diode Z658A limits the timing voltage  $V_{TIM}$  to the break-over voltage  $V_Z$  (i.e., approximately 40 volts), the timing voltage  $V_{TIM}$  is prevented from exceeding the voltage threshold  $V_{TH}$ . Accordingly, the drive circuit 530 is prevented from repeatedly attempting to render the FETs Q510A, Q510B conductive during each half cycle in the event of an overcurrent condition.

[0118] The timing voltage  $V_{TIM}$  is prevented from exceeding the voltage threshold  $V_{TH}$  until the voltage  $\Delta V$  across the capacitor C652A decays to approximately the break-over voltage  $V_Z$  of the zener diode Z658A minus the break-over voltage  $V_{BR}$  of the diac 532. The capacitor C652A discharges slowly through the discharge resistor R656A, such that the time required for the voltage  $\Delta V$  across the capacitor C652A to decay to approximately the break-over voltage  $V_Z$  of the zener diode Z658A minus the break-over voltage  $V_{BR}$  of the diac 532 is long enough such that the drive circuit 530 only attempts to render the FETs Q510A, Q510B conductive once during each half cycle. The voltage across the capacitor C652A decays to substantially zero volts during the negative half cycle such that the voltage across the capacitor C652A is substantially zero volts at the beginning of the next positive half cycle. The capacitor C652B, the diode D654B, the discharge resistor R656B, and the zener diode Z658B of the drive limit circuit 650 operate in a similar fashion during the negative half cycles. An example of the drive limit circuit 650 is described in greater detail in commonly-

assigned U.S. Pat. No. 7,570,031, issued Aug. 4, 2009, entitled METHOD AND APPARATUS FOR PREVENTING MULTIPLE ATTEMPTED FIRINGS OF A SEMI-CONDUCTOR SWITCH IN A LOAD CONTROL DEVICE, the entire disclosure of which is hereby incorporated by reference.

[0119] FIG. 16 is a simplified schematic diagram of a dimmer switch 700 according to a seventh embodiment of the present invention. The dimmer switch 700 comprises a drive circuit 730 that includes a single pulse transformer 734. The pulse transformer 734 has a single primary winding and secondary winding having a tap connection 734'. The diac 532 is coupled in series with the single primary winding of the pulse transformer 734. The series combination of the zener diode Z536A and the capacitor C535A is coupled between one end of the secondary winding and the tap connection 734' of the pulse transformer 734. The series combination of the diode Z536B and the capacitor C535B is coupled between the other end of the secondary winding and the tap connection 734' of the pulse transformer 734. The drive circuit 730 of the seventh embodiment operates to render the FETs Q510A, Q510B conductive and non-conductive in the same manner as the drive circuit 530 of the fifth embodiment.

[0120] FIG. 17 is a simplified schematic diagram of a dimmer switch 800 according to an eighth embodiment of the present invention. The dimmer switch 800 comprises a mechanical air-gap switch S814 and two FETs Q810A, Q810B coupled in anti-series connection between the hot terminal H and the dimmed hot terminal DH for control of the amount of power delivered to the connected LED driver 102. As in the fifth, sixth, and seventh embodiments, the FETs Q810A, Q810B have control inputs (i.e., gates) that receive respective gate voltages  $V_{G1}$ ,  $V_{G2}$  for rendering the FETs conductive and non-conductive. The LED light source 104 is off when the switch S814 is open, and is on when the switch is closed. The dimmer switch 800 comprises a control circuit that includes a timing circuit 820 and a power supply 880 and is operable to conduct a control current  $I_{CNTL}$  through the LED driver 102. The timing circuit 820 conducts a timing current  $I_{TIM}$  in order to generate a timing voltage  $V_{TIM}$  (as in the fifth embodiment). The dimmer switch 800 further comprises a drive circuit 830 for rendering the FETs 810A, Q810B conductive and non-conductive in response to the timing voltage  $V_{TIM}$  and an overcurrent protection circuit 860 for rendering the FETs 810A, Q810B non-conductive in response to an overcurrent condition through the FETs.

[0121] The power supply 880 generates a DC supply voltage  $V_S$  (e.g., approximately 14.4 volts) for powering the drive circuit 830 and the overcurrent protection circuit 860. The power supply 880 conducts a charging current  $I_{CHRG}$  through the LED driver 102 when the dimmer switch 800 is not conducting the load current  $I_{LOAD}$  to the LED driver and the magnitude of the voltage developed across the dimmer switch is approximately equal to the magnitude of the AC line voltage  $V_{AC}$ . The control current  $I_{CNTL}$  conducted through the LED driver 102 is approximately equal to the sum of the timing current  $I_{TIM}$  of the timing circuit 820 and the charging current  $I_{CHRG}$  of the power supply 880.

[0122] The power supply 880 comprises a diode D881 coupled to the hot terminal H (via the switch S814), such that the power supply 880 only charges during the positive half cycles of the AC power source 105. The power supply 880 includes a pass-transistor circuit that operates to gen-

erate the supply voltage  $V_S$  across a capacitor C882 (e.g., having a capacitance of approximately 10  $\mu$ F). The pass-transistor circuit comprises an NPN bipolar junction transistor Q883, a resistor R884 (e.g., having a resistance of approximately 220 $\Omega$ ), a resistor R885 (e.g., having a resistance of approximately 470 k $\Omega$ ), and a zener diode Z886. The capacitor C882 is coupled to the emitter of the transistor Q883, such that the capacitor is able to charge through the transistor. The zener diode Z886 is coupled to the base of the transistor Q883 and has a break-over voltage of, for example, approximately 15V, such that the capacitor C882 is able to charge to a voltage equal to approximately the break-over voltage minus the base-emitter drop of the transistor.

[0123] The power supply 880 further comprises snap-on circuit including a PNP bipolar junction transistor Q887, a resistor R888 (e.g., having a resistance of approximately 22 k $\Omega$ ), and a zener diode Z889. The resistor R888 and the zener diode Z889 are coupled in series with the base of the transistor Q887, and the collector of the transistor Q887 is coupled to a capacitor C890. The zener diode Z889 has a break-over voltage of, for example, approximately 12 V, such that the voltage across the capacitor C882 is coupled across the capacitor C890 when the magnitude of the voltage across the capacitor C882 exceeds approximately the break-over voltage of the zener diode Z889 plus the emitter-base drop of the transistor Q887. When the magnitude of the voltage across the capacitor C882 drops below approximately the break-over voltage of the zener diode Z889 plus the emitter-base drop of the transistor Q887, the voltage across the capacitor C882 is disconnected from the capacitor C890, such that the supply voltage  $V_S$  will drop to approximately circuit common (i.e., approximately zero volts).

[0124] The timing circuit 820 conducts the timing current  $I_{TIM}$  and generates the timing voltage  $V_{TIM}$  across a capacitor C822 (e.g., having a capacitance of approximately 0.047  $\mu$ F). The capacitor C822 charges from the AC power source 105 through resistors R824, R825 (e.g., having resistances of approximately 27 k $\Omega$  and 10 k $\Omega$ , respectively) and a potentiometer R826 (e.g., having a resistance ranging from approximately 0 k $\Omega$  to 300 k $\Omega$ ). A calibration potentiometer R827 is coupled across the potentiometer R826 and has, for example, a resistance ranging from approximately 0 to 500 k $\Omega$ . The timing circuit 820 further comprises a diac 828, which has a break-over voltage of, for example, approximately 64V, and operates to provide voltage compensation for the timing circuit (in a similar manner as the diac 528 of the timing circuit 520 of the fifth embodiment).

[0125] The drive circuit 830 generates the gate voltages  $V_{G1}$ ,  $V_{G2}$  for rendering the FETs Q810A, Q810B conductive and non-conductive on a complementary basis in response to the timing voltage  $V_{TIM}$  of the timing circuit 820. The drive circuit 830 comprises a diac 832 (e.g., having a break-over voltage of approximately 32 volts), a resistor R834 (e.g., having a resistance of approximately 680 $\Omega$ ), and two optocouplers U835A, U835B. When the magnitude of the timing voltage  $V_{TIM}$  exceeds approximately the break-over voltage of the diac 832, the diac conducts a firing current  $I_{FIRE}$  through the input photodiode of the first optocoupler U835A during the positive half cycles, and through the input photodiode of the second optocoupler U835B during the negative half cycles. Accordingly, the output phototransistor of the first optocoupler U835A is rendered conductive during the positive half cycles, and the output phototransistor of the

second optocoupler U835B is rendered conductive during the negative half cycles. The output phototransistors of the optocouplers U835A, U835B are between the supply voltage  $V_S$  and circuit common through respective resistors R836, R838, which each have resistances of, for example, approximately 4.7 k $\Omega$ .

[0126] The output phototransistors of the optocouplers U835A, U835B are also coupled to set-reset (SR) latches U840A, U840B, U840C, U840D, which operate to generate the gate voltages  $V_{G1}$ ,  $V_{G2}$  and to thus render the FETs Q810A, Q810B conductive and non-conductive on the complementary basis. For example, the SR latches U840A, U840B, U840C, U840D may be implemented as part of a single integrated circuit (IC), which may be powered by the supply voltage  $V_S$ . As shown in FIG. 17, the output phototransistor of the first optocoupler U835A is coupled to the set input of the first SR latch U840A and to the reset input of the second SR latch U840B. The output phototransistor of the second optocoupler U835B is coupled to the set input of the second SR latch U840B and to the reset input of the first SR latch U840A. The output of the first SR latch U840A is coupled to the gate of the first FET Q810A and the output of the second SR latch U840B is coupled to the gate of the second FET Q810B through respective resistors R842, R852, which each have a resistance of, for example, approximately 47 k $\Omega$ .

[0127] When the output phototransistor of the first optocoupler U835A is rendered conductive during the positive half cycles, the output of the first SR latch U840A is driven high towards the supply voltage  $V_S$  (thus rendering the first FET Q810A conductive), while the output of the second SR latch U840B is driven low towards circuit common (thus rendering the second FET Q810B non-conductive). Similarly, when the output phototransistor of the second optocoupler U835B is rendered conductive during the negative half cycles, the output of the second SR latch U840B is driven high towards the supply voltage  $V_S$  (thus rendering the second FET Q810B conductive), while the output of the first SR latch U840A is driven low towards circuit common (thus rendering the first FET Q810A non-conductive). Since the set input of the first SR latch U840A is coupled to the reset input of the second SR latch U840B, and the set input of the second SR latch is coupled to the reset input of the first SR latch, the FETs Q810A, Q810B are driven in a complementary manner (as in the fifth embodiment), such that one of the FETs is conductive, while the other FET is non-conductive.

[0128] The overcurrent protection circuit 860 is coupled to the set inputs of the third and fourth SR latches U840C, U840D for rendering the FETs Q810A, Q810B non-conductive in the event of an overcurrent condition through the FETs. The output of the third SR latch U840C is coupled to the base of an NPN bipolar junction transistor Q844 via a resistor R846 (e.g., having a resistance of approximately 18 k $\Omega$ ). The collector of the transistor Q844 is coupled to the gate of the first FET Q810A via a resistor R848 (e.g., having a resistance of approximately 330 $\Omega$ ). The drive circuit 830 comprises a similar circuit for coupling the output of the fourth SR latch U840D to the gate of the second FET Q810B.

[0129] The overcurrent protection circuit 860 comprises a sense resistor R870 (e.g., having a resistance of approximately 0.015 $\Omega$ ). The sense resistor R870 is coupled in series between the FETs Q810A, Q810B, and circuit common is

referenced to one side of the sense resistor (as shown in FIG. 12), such that the magnitude of the voltage generated across the sense resistor is proportional to the magnitude of the load current  $I_{LOAD}$ . The sense resistor R870 is coupled to the base of an NPN bipolar junction transistor Q861 via a resistor R862 (e.g., having a resistance of approximately 2.2 k $\Omega$ ). A resistor R863 is coupled between the base and the emitter of the transistor Q861 and has a resistance of, for example, approximately 4.7 k $\Omega$ . The emitter of the transistor Q861 is coupled to circuit common and the collector is coupled to the supply voltage  $V_S$  via two resistors R864, R865 (e.g., having resistances of approximately 18 k $\Omega$  and 4.7 k $\Omega$ , respectively). The junction of the resistors R864, R865 is coupled to the base of a PNP bipolar junction transistor Q866. The emitter of the transistor Q866 is coupled to the supply voltage  $V_S$  and the collector is coupled to circuit common through a resistor R867 (e.g., having a resistance of approximately 510 $\Omega$ ). The collector of the transistor Q866 is coupled to the set input of the third SR latch U840C for rendering the first FET Q810A non-conductive in the event of overcurrent conditions during the positive half cycles. The overcurrent protection circuit 860 comprises a similar circuit (including transistors Q871, Q876, and resistors R872, R873, R874, R875, R877) for rendering the second FET Q810B non-conductive in the event of overcurrent conditions during the negative half cycles.

[0130] In the event of an overcurrent condition during a positive half cycle, the overcurrent protection circuit 860 drives the set input of the third SR latch U840C high towards the supply voltage  $V_S$ . Thus, the transistor Q844 is rendered conductive pulling the gate voltage  $V_{G1}$  down towards circuit common and rendering the first FET Q810A non-conductive. The output phototransistor of the second optocoupler U835B is coupled to the reset input of the third SR latch U840C, such that the overcurrent protection is reset during the next half cycle (i.e., the negative half cycle). Specifically, when the output phototransistor of the second optocoupler U835B is rendered conductive during the negative half cycles, the reset input of the third SR latch U840C is driven high towards the supply voltage  $V_S$ , thus rendering the transistor Q844 non-conductive and allowing the first SR latch U840A to control the first FET Q810A. Similarly, the overcurrent protection circuit 860 drives the set input of the fourth SR latch U840D high towards the supply voltage  $V_S$ , thus rendering the second FET Q810B non-conductive in the event of an overcurrent condition during a negative half cycle. The reset input of the fourth SR latch U840D is driven high when the output phototransistor of the first optocoupler U835A is rendered conductive during the positive half cycles, thus allowing the second SR latch U840B to once again control the second FET Q810B.

[0131] FIG. 18 is a simplified schematic diagram of a "smart" dimmer switch 900 that offers advanced features and functionality to a user according to a ninth embodiment of the present invention. As shown in FIG. 18, the bidirectional semiconductor switch 110 of the dimmer switch 900 of the ninth embodiment is implemented as the triac 110' that is driven by the gate coupling circuit 350 having two anti-series-connected FETs Q352a, Q352b (as in the dimmer switch 300 of the third embodiment). The dimmer switch 900 comprises an air-gap switch S912 that may be actuated by an air-gap actuator (not shown) to allow for an air-gap disconnect between the AC power source 105 and the high-efficiency lighting load 101 when servicing the

high-efficiency lighting load. The air-gap switch **S912** is not the primary means for toggling the LED light source **104** on and off as will be described in greater detail below. An example of a smart dimmer switch is described in greater detail in previously-referenced U.S. Pat. No. 5,248,919.

**[0132]** The dimmer switch **900** comprises a digital control circuit **915** having a microprocessor **930** for generating a drive voltage  $V_{DR}$  (which is the same as the drive voltage  $V_{DR-INV}$  of the third embodiment shown in FIG. 7). Alternatively, the microprocessor **930** may be implemented as a microcontroller, a programmable logic device (PLD), an application specific integrated circuit (ASIC), a field-programmable gate array (FPGA), or any suitable controller or processing device. In addition, the triac **110'** of the dimmer switch **900** could alternatively be driven by the opto-coupler **U152** of the dimmer switch **100** of the first embodiment. Further, the bidirectional semiconductor switch **110** of the dimmer switch **900** of the ninth embodiment could alternatively be implemented as two FETs in anti-series connection that are simultaneously controlled to be conductive and non-conductive (i.e., in a similar manner as the FETs **Q210A**, **Q210B** of the dimmer switch **200** of the second embodiment).

**[0133]** The digital control circuit **915** also comprises a power supply **920** operable to conduct a charging current  $I_{CHRG}$  through the LED driver **102** in order to generate a DC supply voltage  $V_{CC}$ . For example, the power supply **920** may comprise a pass-transistor circuit (as in the dimmer switch **100** of the first embodiment shown in FIG. 4) or any suitable power supply that does not draw a large charging current through the LED driver **102**. The digital control circuit **915** comprises a voltage divider having two resistors **R934**, **R935** for generating a scaled voltage  $V_{SCALED}$  having a magnitude suitable to be provided to the microprocessor **930**. The scaled voltage  $V_{SCALED}$  is representative of the voltage developed across the bidirectional semiconductor switch **110**. The microprocessor **930** may have an analog-to-digital converter (ADC) for sampling the scaled voltage  $V_{SCALED}$ , such that the microprocessor **930** is operable to determine the zero-crossings of the phase control voltage  $V_{PC}$  in response to the voltage developed across the bidirectional semiconductor switch **110**.

**[0134]** The digital control circuit **915** further comprises a toggle tactile switch  $S_{TOGGLE}$ , a raise tactile switch  $S_{RAISE}$ , and a lower tactile switch  $S_{LOWER}$  for receiving user inputs. The toggle tactile switch  $S_{TOGGLE}$  may be mechanically coupled to a toggle actuator or push button. The raise and lower switches  $S_{RAISE}$ ,  $S_{LOWER}$  may be mechanically coupled to, for example, separate raise and lower buttons, respectively, or to a rocker switch having an upper portion and a lower portion. The toggle switch  $S_{TOGGLE}$  is coupled in series with a resistor **R936** between the supply voltage  $V_{CC}$  and circuit common, and generates a toggle control signal  $V_{TOGGLE}$ . The raise switch  $S_{RAISE}$  is coupled in series with a resistor **R938** between the supply voltage  $V_{CC}$  and circuit common, and generates a raise control signal  $V_{RAISE}$ . The lower switch  $S_{LOWER}$  is coupled in series with a resistor **R938** between the supply voltage  $V_{CC}$  and circuit common, and generates a lower control signal  $V_{LOWER}$ . The toggle control signal  $V_{TOGGLE}$ , the raise control signal  $V_{RAISE}$ , and the lower control signal  $V_{LOWER}$  are received by the microprocessor **930**. The microprocessor **930** is operable to toggle the LED light source **104** on and off in response to subsequent actuations of the toggle switch  $S_{TOGGLE}$ . The micro-

processor **930** is operable to increase the target intensity  $L_{TRGT}$  of the LED light source **104** in response to actuations of the raise switch  $S_{RAISE}$  and to decrease the target intensity  $L_{TRGT}$  in response to actuations of the lower switch  $S_{LOWER}$ . Alternatively, the digital control circuit **915** could comprise a potentiometer for generating a DC voltage that is representative of the desired intensity of the LED light source **104** and varies, for example, in magnitude in response to the position of an intensity adjustment actuator of the dimmer switch **900** (i.e., similar to the potentiometer **R144** and the intensity adjustment actuator **118** of the dimmer switch **100** of the first embodiment).

**[0135]** In addition, the dimmer switch **900** may comprise a visual display (not shown), such as, a linear array of light-emitting diodes (LEDs), for displaying feedback to a user of the dimmer switch **900**. For example, the microprocessor **930** may illuminate one of the LEDs to display a visual representation of the target intensity  $L_{TRGT}$  of the LED light source **104**. When the LED light source **104** is off, the microprocessor **930** may illuminate the LEDs dimly to provide a nightlight feature. One of the LEDs may be illuminated to a greater intensity to display the target intensity  $L_{TRGT}$  to which the microprocessor **930** will control the LED light source **104** when the LED light source is turned back on. The nightlight feature is described in greater detail in commonly-assigned U.S. Pat. No. 5,399,940, issued Mar. 21, 1995, entitled LIGHTING INDICATING DEVICE HAVING PLURAL ILLUMINATING ELEMENTS WITH ALL SUCH ELEMENTS BEING ILLUMINATED WITH ONE BEING GREATER THAN THE OTHERS, the entire disclosure of which is hereby incorporated by reference.

**[0136]** Further, the microprocessor **930** of the dimmer switch **900** may alternatively be operable to receive a digital message from a wired or wireless signal receiver. For example, the digital control circuit **915** of the dimmer switch **900** may comprise a radio-frequency (RF) communication circuit (not shown), e.g., an RF transceiver, and an antenna (not shown), for transmitting and receiving RF signals. The microprocessor **930** may be operable to control the bidirectional semiconductor switch **110** in response to the digital messages received via the RF signals. The microprocessor **930** and the RF transceiver are both able to be put in a sleep mode (i.e., low-power mode) to conserve battery power. During the sleep mode, the RF transceiver is operable to wake up periodically to sample (e.g., listen) for RF energy at a sampling period  $T_{SAMPLE}$ . In the event that the RF transceiver does detect the presence of any RF signals **106**, the RF transceiver is operable to wake up the microprocessor **930**, such that the microprocessor can begin processing the received RF signal. Each time that the microprocessor **930** wakes up, additional power is consumed by the microprocessor (since the microprocessor is fully powered when awake). Alternatively, the RF communication circuit of the dimmer switch **900** may simply comprise an RF receiver or an RF transmitter for only receiving or transmitting RF signals, respectively. Examples of RF load control devices and antennas for wall-mounted load control devices are described in greater detail in commonly-assigned U.S. Pat. No. 5,982,103, issued Nov. 9, 1999, and U.S. Pat. No. 7,362,285, issued Apr. 22, 2008, both entitled COMPACT RADIO FREQUENCY TRANSMITTING AND RECEIVING ANTENNA AND CONTROL DEVICE EMPLOYING SAME, and U.S. patent application Ser. No. 13/415,537, filed Mar. 8, 2012, entitled LOW-POWER RADIO-FRE-



QUENCY RECEIVER, the entire disclosures of which are hereby incorporated by reference.

[0137] FIG. 19 is a simplified flowchart of a switch procedure 1000 executed by the microprocessor 930 in response to an actuation of one of the raise switch  $S_{RAISE}$  or the lower switch  $S_{LOWER}$  at step 1010 (i.e., if either of the raise control signal  $V_{RAISE}$  and the lower control signal  $V_{LOWER}$  are pulled down to circuit common). If the raise switch  $S_{RAISE}$  is actuated at step 1012, the microprocessor 930 increases the target intensity  $L_{TRGT}$  of the LED light source 104 at step 1014 by decreasing a firing time  $T_{FIRE}$  (which is approximately equal to the non-conduction time  $T_{NC}$  shown in FIGS. 3A and 3B). If the lower switch  $S_{LOWER}$  is actuated at step 1016, the microprocessor 930 decreases the target intensity  $L_{TRGT}$  of the LED light source 104 by increasing the firing time  $T_{FIRE}$  at step 1018, before the button procedure 1000 exits.

[0138] FIG. 20 is a simplified flowchart of a control procedure 1100 periodically executed by the microprocessor 930 (e.g., every 100  $\mu$ sec) to sample the scaled voltage  $V_{SCALED}$  and generate the drive voltage  $V_{DR}$ . First, the microprocessor 930 samples the scaled voltage  $V_{SCALED}$  using the ADC at step 1110. At step 1112, the microprocessor 930 determines if the scaled voltage  $V_{SCALED}$  is increasing in magnitude and if the present sample is greater than the previous sample in order to detect a positive-going transition of the scaled voltage  $V_{SCALED}$  across a zero-crossing threshold. If the microprocessor 930 detects a positive-going transition across the zero-crossing threshold at step 1112 and a RESET flag is set at step 1114, the microprocessor 930 clears the RESET flag at step 1116. The microprocessor 930 then initializes a timer to zero and starts the timer increasing in value with respect to time at step 1118, before the control procedure 1100 exits. If the RESET flag is not set at step 1114, the microprocessor 930 does not restart the timer at step 1118.

[0139] If the timer is equal to the firing time  $T_{FIRE}$  at step 1120, the microprocessor 930 drives the drive voltage  $V_{DR}$  low to approximately circuit common to render the bidirectional semiconductor switch 110 conductive at step 1122, and the control procedure 1100 exits. If the time is equal to a total time  $T_{TOTAL}$  at step 1124, the microprocessor 930 drives the drive voltage  $V_{DR}$  high to approximately the supply voltage  $V_{CC}$  to render the bidirectional semiconductor switch 110 non-conductive at step 1126. The total time  $T_{TOTAL}$  may be equal to the fixed amount of time  $T_{TIM}$  that the timing circuit 130 generates the timing voltage  $V_{TIM}$  in the dimmer switch 100 of the first embodiment (i.e., approximately 7.5 msec). At step 1128, the microprocessor 930 sets the RESET flag at step 1128, and the control procedure 1100 exits. The RESET flag allows the microprocessor 930 to ensure that the timer is not restarted until after the total time  $T_{TOTAL}$ .

[0140] FIG. 21 is a simplified schematic diagram of a dimmer switch 1200 according to a tenth embodiment of the present invention. The dimmer switch 1200 includes a gate coupling circuit 1250 having two FETs Q1252A, Q1252B coupled in anti-series connection between the gate and a first one of the main load terminals of the triac 110' (e.g., the hot terminal H of the dimmer switch). The sources of the FETs Q1252A, Q1252B are coupled together through two resistors R1253, R1254 (e.g., each having a resistance of approximately 5.6 $\Omega$ ), where the junction of the two resistors R1253, R1254 is coupled to circuit common.

[0141] The dimmer switch 1200 comprises a digital control circuit 1215 having a microprocessor 1230 that is responsive to actuators 1236 (e.g., such as the toggle tactile switch  $S_{TOGGLE}$ , the raise tactile switch  $S_{RAISE}$ , and the lower tactile switch  $S_{LOWER}$  of the ninth embodiment). The digital control circuit 1215 comprises a zero-cross detect circuit 1234 that generates a zero-cross voltage  $V_{ZC}$  that is representative of the zero-crossings of the AC line voltage. The digital control circuit 1215 also comprises a power supply 1220 operable to conduct a charging current  $I_{CHRG}$  through the LED driver 102 for generating a first DC supply voltage  $V_{CC1}$  (e.g., approximately 8 volts) for driving the FETs Q1252A, Q1252B and a second DC supply voltage  $V_{CC2}$  (e.g., approximately 4 volts) for powering the microprocessor 1230. Both of the first and second DC supply voltages  $V_{CC1}$ ,  $V_{CC2}$  are referenced to circuit common and the power supply 1220 conducts the charging current  $I_{CHRG}$  through circuit common. For example, the power supply 1220 may comprise a resistor-zener power supply for generating the first DC supply voltage  $V_{CC1}$  and a high-efficiency switching power supply for generating the second DC supply voltage  $V_{CC2}$ . Alternatively, the power supply 1220 may comprise one or more linear regulators, or other suitable power supply, in addition to any combination of linear regulators, switching power supplies, and resistor-zener power supplies.

[0142] The gate coupling circuit 1250 of the tenth embodiment is very similar to the gate coupling circuit 350 of the third embodiment. However, the gate coupling circuit 1250 of the tenth embodiment comprises first and second gate drive circuits 1260, 1270 that allow for independent control the FETs Q1252A, Q1252B. The microprocessor 1230 generates two drive voltages  $V_{DR1}$ ,  $V_{DR2}$  that are received by the respective gate drive circuits 1260, 1270 for rendering the respective FETs Q1252A, Q1252B conductive and non-conductive, such that the triac 110' may be rendered conductive to conduct the load current  $I_{LOAD}$  to the LED driver 102. The dimmer switch 1200 comprises a resistor R1258, which has a resistance of, for example, approximately 90.9 $\Omega$  and is coupled between the gate and one of the main load terminals of the triac 110' (e.g., to the dimmed hot terminal DH of the dimmer switch).

[0143] In addition, the dimmer switch 1200 comprises a controllable switching circuit 1280 coupled in series with the anti-series-connected FETs Q1252A, Q1252B and the gate of the triac 110'. The microprocessor 1230 generates a switch control voltage  $V_{SW}$  for rendering the controllable switching circuit 1280 conductive and non-conductive. When the controllable switching circuit 1280 is conductive, the FETs Q1252A, Q1252B are able to conduct a gate current  $I_G$  through the gate of the triac 110' to render the triac conductive. The microprocessor 1230 is operable to disconnect the gate of the triac 110' from the FETs Q1252A, Q1252B before the end of each half-cycle of the AC line voltage, such that the triac is able to commutate off before the end of the half-cycle. However, the FETs Q1252A, Q1252B may conduct the load current  $I_{LOAD}$  to the LED driver 102 after the triac 110' and before the end of the present half-cycle, as will be described in greater detail below.

[0144] FIG. 22 is a simplified schematic diagram of a portion of the dimmer switch 1200 showing the first and second gate drive circuits 1260, 1270 and the controllable switching circuit 1280 in greater detail. The first gate drive

circuit **1260** comprises an NPN bipolar junction transistor **Q1261** having a base that receives the first drive voltage  $V_{DR1}$  via a resistor **R1262** (e.g., having a resistance of approximately 200 k $\Omega$ ). The collector of the transistor **Q1261** is coupled to the first DC supply voltage  $V_{CC1}$  through a resistor **R1263** (e.g., having a resistance of approximately 200 k $\Omega$ ), and to the base of another NPN bipolar junction transistor **Q1264**. The collector-emitter junction of the transistor **Q1264** is coupled in series with a diode **D1265** and the collector-emitter junction of another NPN bipolar junction transistor **Q1266**. The base of the transistor **Q1266** is coupled to the first DC supply voltage  $V_{CC1}$  through a resistor **R1267** (e.g., having a resistance of approximately 200 k $\Omega$ ) and to the collector of the transistor **Q1266**. The junction of the transistor **Q1266** and the diode **D1265** is coupled to the gate of the first FET **Q1252A** through a gate resistor **R1268** (e.g., having a resistance of approximately 47 $\Omega$ ).

[0145] When the first drive voltage  $V_{DR1}$  is low (i.e., at approximately circuit common), the transistor **Q1261** is non-conductive, such that the base of the transistor **Q1265** is pulled up towards the first DC supply voltage  $V_{CC1}$ . Accordingly, the transistor **Q1265** is rendered conductive, pulling the base of the transistor **Q1266** and the gate of the first FET **Q1252A** down towards circuit common, such that the FET is non-conductive. However, when the first drive voltage  $V_{DR1}$  is high (i.e., at approximately the first DC supply voltage  $V_{CC1}$ ), the transistor **Q1261** becomes conductive, such that the transistor **Q1265** is rendered non-conductive. Thus, the transistor **Q1266** becomes conductive and the gate of the first FET **Q1252A** is driven up towards the first DC supply voltage  $V_{CC1}$ , such that the FET is rendered conductive. The second gate drive circuit **1270** has an identical structure and operation for rendering the second FET **Q1252B** conductive and non-conductive in response to the second drive voltage  $V_{DR2}$ .

[0146] The controllable switching circuit **1280** is coupled between the anti-series-connected FETs **Q1252A**, **Q1252B** and the gate of the triac **110'** and is responsive to the switch control voltage  $V_{SW}$  from the microprocessor **1230**. The gate of the triac **110'** is coupled to one of the main terminals through the parallel combination of a capacitor **C1290** (e.g., having a capacitance of approximately 0.1  $\mu$ F) and a resistor **R1292** (e.g., having a resistance of approximately 47 $\Omega$ ). The controllable switching circuit **1280** includes a full-wave rectifier bridge comprises four diodes **D1281**-**D1284**. The AC terminals of the rectifier bridge are coupled in series with the gate of the triac **110'**, while an NPN bipolar junction transistor **Q1285** is coupled across the DC terminals of the rectifier bridge. The controllable switching circuit **1280** also comprises an optocoupler **U1286** having an output phototransistor that is coupled in series with a resistor **R1287** across the DC terminals of the bridge. For example, the resistor **R1287** may have a resistance of approximately 150 k $\Omega$ . The switch control voltage  $V_{SW}$  is coupled to the input photodiode of the optocoupler **U1286** via a resistor **R1288** (e.g., having a resistance of approximately 10 k $\Omega$ ). When the switch control voltage  $V_{SW}$  is low, the output phototransistor of the optocoupler **U1286** is non-conductive, such that the transistor **Q1285** is non-conductive (i.e., the controllable switching circuit **1280** is non-conductive). However, when the switch control-voltage  $V_{SW}$  is high, the output phototransistor of the optocoupler **U1286** is rendered conductive, such that the transistor **Q1285** is conductive (i.e., the controllable

switching circuit **1280** is conductive and the gate of the triac **110'** is coupled to the anti-series-connected FETs **Q1252A**, **Q1252B**).

[0147] FIG. **23** shows example waveforms illustrating the operation of the dimmer switch **1200** according to the tenth embodiment of the present invention. The microprocessor **1230** is operable to determine the zero-crossing of the AC line voltage at time  $t_1$  in response to the zero-cross voltage  $V_{ZC}$  generated by the zero-cross detect circuit **1234**. At the beginning of each half-cycle, the FETs **Q1252A**, **Q1252B** are rendered non-conductive, such that the first FET **Q1252A** blocks current during the positive half-cycles and the second FET **Q1252B** blocks current during the negative half-cycles. The microprocessor **1230** drives both of the drive voltages  $V_{DR1}$ ,  $V_{DR2}$  high at the same time, such that the FETs **Q1252A**, **Q1252B** are operable to conduct the gate current  $I_G$  through the gate of the triac **110'** to render the triac conductive at the desired phase angle (e.g., at time  $t_3$  as shown in FIG. **23**).

[0148] During the positive half-cycles, the microprocessor **1230** drives the second drive voltage  $V_{DR2}$  low at time  $t_5$  before the end of the half-cycle (i.e., at time  $t_6$  in FIG. **23**), such that the second FET **Q1252B** will be non-conductive and ready to block current at the beginning of the negative half-cycle. After the second drive voltage  $V_{DR2}$  is driven low at time  $t_5$ , the second FET **Q1252B** is operable to conduct current through its body diode until the end of the half-cycle. The microprocessor **1230** drives the first drive voltage  $V_{DR1}$  low after the end of the half-cycle at time  $t_7$ , such that the first FET **Q1252A** remains conductive until the end of the present positive half-cycle. Similarly, during the negatives half-cycles, the microprocessor **1230** drives the first drive voltage  $V_{DR1}$  low before the end of the half-cycle and drives the second drive voltage  $V_{DR2}$  low after the end of the half-cycle.

[0149] The microprocessor **1230** drives the switch control voltage  $V_{SW}$  high (e.g., at time  $t_2$  as shown in FIG. **23**) to cause the controllable switching circuit **1280** to become conductive) prior to rendering the FETs **Q1252A**, **Q1252B** conductive, for example, approximately 40  $\mu$ sec before the time  $t_3$  when the FETs are rendered conductive. If the FETs **Q1252A**, **Q1252B** allow the gate of the triac **110'** to conduct the gate current  $I_G$  too close to the end of the half-cycle, the triac **110'** may mistakenly be rendered conductive at the beginning of the next half-cycle, which could cause the triac to be conductive for the entire next half-cycle and thus cause flicker in the LED light source **104**. Therefore, the microprocessor **1230** drives the switch control voltage  $V_{SW}$  low (e.g., at time  $t_4$  in FIG. **23**) to cause the controllable switching circuit **1280** to become non-conductive before the end of the present half-cycle, e.g., approximately 600-1000  $\mu$ sec before the end of the half-cycle (i.e., at time  $t_6$  in FIG. **23**). Since the controllable switching circuit **1280** becomes non-conductive before the end of the half-cycle, the triac **110'** is able to commutate off when the magnitude of the load current  $I_{LOAD}$  drops below the rated holding current of the triac. The triac **110'** cannot be rendered conductive again during the present half-cycle and will remain non-conductive at the beginning of the next half-cycle. If the LED driver **102** needs to conduct current after the triac **110'** commutates off, the FETs **Q1252A**, **Q1252B** are able to conduct the load current **LOAD**. Accordingly, the dimmer switch **1200** is able to conduct current through the LED driver **102** independent

of the rated holding current of the triac **110'** and without driving the triac **110'** too close to the next half-cycle.

[0150] Thus, as described above, the gate current  $I_G$  is able to be conducted through a first current path comprising the controllable switching circuit **1280** and the FETs **Q1252A**, **Q1252B** of the gate coupling circuit **1250** between the firing time  $t_3$  and a transition time before the end of the half-cycle, e.g., at time  $t_4$  when the controllable switching circuit **1280** is rendered non-conductive. In addition, the load current  $I_{LOAD}$  is able to be conducted through a second current path comprising the resistor **R1258** and the FETs **Q1252A**, **Q1252B** of the gate coupling circuit **1250** when the triac **110'** commutates off near the end of the half-cycle (e.g., after the transition time  $t_4$  when the controllable switching circuit **1280** is rendered non-conductive) until the end of the half-cycle.

[0151] The dimmer switch **1200** comprises two independently-controllable paths for the load current  $I_{LOAD}$  to flow. Specifically, the dimmer switch **1200** comprises a first load-current path having a latching behavior (e.g., the triac **110'**) that is able to conduct the load current  $I_{LOAD}$  between the firing time  $t_3$  until the triac commutates off near the end of the half-cycle (e.g., after the transition time  $t_4$ ). The dimmer switch **1200** comprises a second load-current path (e.g., the series combination of the resistor **R1258** and the FETs **Q1252A**, **Q1252B** of the gate coupling circuit **1250**) that is able to conduct the load current  $I_{LOAD}$  when the triac **110'** commutates off near and prior to the end of the half-cycle (e.g., after the transition time  $t_4$  when the controllable switching circuit **1280** is rendered non-conductive) until the end of the half-cycle, thereby ensuring a smooth and uninterrupted path for the load current  $I_{LOAD}$  to flow through the duration of the desired conduction time in each half-cycle of the AC power source. The second load-current path may be characterized in having a non-latching behavior, such that conduction of current through the second load-current path may be started and stopped in response to one or more control signals (e.g., the drive voltages  $V_{DR1}$ ,  $V_{DR2}$ ).

[0152] Since the dimmer switch **1200** comprises the microprocessor **1230**, the dimmer switch may offer advanced features and functionality to a user of the dimmer switch. The user may be able adjust the features and functionality of the dimmer switch **1200** using, for example, an advanced programming mode. The microprocessor **1230** may be operable to enter the advanced programming mode in response to one or more actuations of the actuators **1236**. For example, the user may adjust the low-end intensity  $L_{IE}$  and the high-end intensity  $L_{RE}$  between which the microprocessor **1230** may control the target intensity  $L_{TRGT}$  of the LED light source **104**. A dimmer switch having an advanced programming mode is described in greater detail in commonly-assigned U.S. Pat. No. 7,190,125, issued Mar. 13, 2007, entitled PROGRAMMABLE WALLBOX DIMMER, the entire disclosure of which is hereby incorporated by reference.

[0153] In addition, the user may cause the dimmer switch **1200** to enter a low-power mode using the advanced programming mode, i.e., in response to one or more actuations of the actuators **1236**. In the low-power mode, the microprocessor **1230** may disable one or more of the electrical circuits of the dimmer switch **1200** (i.e., loads of the power supply **1220**) to decrease the amount of current conducted through the LED driver **102** when the LED light source **104**

is off. For example, the microprocessor **1230** may be operable to turn off the LEDs, such that the dimmer switch **1200** does not provide the nightlight feature when the LED light source **104** is off. Further, the microprocessor **1230** may be operable to disable the RF communication circuit when the LED light source **104** is off. Alternatively, the microprocessor **1230** could increase the sampling period  $T_{SAMPLE}$ , such that the RF communication circuit wakes up less often to sample for RF energy and thus consumes less power.

[0154] FIG. 24 is a simplified block diagram of a smart dimmer switch **1300** according to an eleventh embodiment of the present invention. The dimmer switch **1300** is very similar to the dimmer switch **1200** of the tenth embodiment. However, the dimmer switch **1300** has an earth ground terminal GND that is adapted to be coupled to earth ground. The zero-crossing detector **1234** and the power supply **1220** of the dimmer switch **1300** are coupled between the hot terminal H and the earth ground terminal GND (rather than the dimmed hot terminal DH). Accordingly, the power supply **1220** conducts the charging current  $I_{CHRG}$  through the earth ground terminal GND (rather than the LED driver **102**).

[0155] The smart dimmer switches **900**, **1200**, **1300** of the ninth, tenth, and eleventh embodiments could alternatively comprise analog dimmer switches, e.g., dimmer switches having the mechanical air-gap switch **S112** coupled to the rocker switch **116** for turning the LED light source **104** on and off and an intensity adjustment actuator **118** for adjusting the intensity of the LED light source **104** as in the first through eighth embodiments. The microprocessors **930**, **1230** of the dimmer switches **900**, **1200**, **1300** of the ninth, tenth, and eleventh embodiments would simply be unpowered when the mechanical air-gap switch **S112** is open.

[0156] FIG. 25 is a simplified block diagram of a load control device, e.g., an electronic switch **1400**, according to a twelfth embodiment of the present invention. The electronic switch **1400** comprises a single actuator **1436** (e.g., a toggle actuator) for simply turning the LED light source **104** on and off (i.e., the electronic switch does not comprise an intensity adjustment actuator). Alternatively, the electronic switch **1400** may comprise a first actuator for turning the LED light source **104** on and a second actuator for turning the LED light source off. The electronic switch **1400** comprises a full-wave rectifier bridge **1414** having four diodes **D1414A**, **D1414B**, **D1414C**, **D1414D**. The rectifier bridge **1414** has AC terminals coupled in series between a hot terminal H and a switched hot terminal SH, and DC terminals for providing the rectified voltage  $V_{RECT}$  to a digital control circuit **1415**. The digital control circuit **1415** comprises a microprocessor **1430** that is responsive to the actuator **1436**, as well as a zero-cross voltage  $V_{ZC}$  generated by a zero-cross detect circuit **1434**. The microprocessor **1430** generates an on-state control signal  $V_{ON}$  that is representative of the state of the LED light source **104** for controlling the triac **110'** as will be described in greater detail below. Specifically, the microprocessor **1430** drives the on-state control signal  $V_{ON}$  low to control the LED light source **104** off and high to control the LED light source **104** on.

[0157] The digital control circuit **1415** is coupled to the gate of the triac **110'** via a gate coupling circuit **1450**. The gate coupling circuit **1450** comprises a single MOS-gated transistor, e.g., a FET **Q1452**, inside of a full-wave rectifier bridge that includes diodes **D1456A**-**D1456D** (as well as the

diode D1414D). Specifically, the full-wave rectifier bridge has AC terminals coupled in series between the hot terminal H and the gate of the triac 110' and DC terminals coupled across the series-combination of the FET Q1452 and a resistor R1454 (e.g., having a resistance of approximately 3.92Ω). The gate coupling circuit 1450 receives a drive voltage  $V_{DR}$  from the digital control circuit 1415, and the drive voltage  $V_{DR}$  is coupled to the gate of the FET Q1452 via a gate drive circuit 1460. When the FET Q1452 is rendered conductive, a gate current  $I_G$  may be conducted through the FET Q1452, the resistor R1454, the diodes D1456A, D1456D, and the gate of the triac 110' during the positive half-cycles to render the triac conductive. During the negative half-cycles, the gate current  $I_G$  may be conducted through the gate of the triac 110', the FET Q1452, the resistor R1454, and the diodes D1456B, D1456C and the diode D1414D. While not shown as such in FIG. 25, the diode D1456B may comprise four diodes coupled in series to ensure that the diode D1456D is forward biased during the positive half-cycles.

[0158] The resistor R1454 forms a constant current source with the FET Q1452, such that the gate current  $I_G$  conducted through the gate of the triac 110' has a constant magnitude. If the resistor R1454 was not included in the gate coupling circuit 1450, the magnitude of the gate current  $I_G$  would be dependent upon the on-resistance  $R_{DS-ON}$  of the FET Q1452 and would be greater in magnitude than when the resistor R1454 was included in the gate coupling circuit 1450, thus requiring FET Q1452 to be capable of conducting larger magnitudes of current. Therefore, the resistor R1454 ensures that the gate current  $I_G$  has a constant and relatively low magnitude that does not put unnecessary stress on the triac 110', the FET Q1452 and the other components of gate coupling circuit 1450.

[0159] The digital control circuit 1415 also comprises an on-state power supply 1420 and an off-state power supply 1422 that are both operable to generate a first DC supply voltage  $V_{CC1}$  (e.g., approximately 8 volts) across a first capacitor C1424 (e.g., having a capacitance of approximately 1000 μF) and a second DC supply voltage  $V_{CC2}$  (e.g., approximately 3.3 volts) across a second capacitor C1426 (e.g., having a capacitance of approximately 47 μF). The digital control circuit 1415 further comprises a boosting power supply, e.g., a charge pump circuit 1428, which receives the first DC supply voltage  $V_{CC1}$  and generates a third boosted DC supply voltage  $V_{CC3}$  (e.g., approximately 15 volts) for driving the FET Q1452 of the gate coupling circuit 1450. The off-state power supply 1422 conducts an off-state charging current  $I_{CHRG-OFF}$  to generate the first and second DC supply voltages  $V_{CC1}$ ,  $V_{CC2}$  when the electronic switch 1400 is non-conductive and the LED light source 104 is off. The off-state power supply 1422 may comprise, for example, a high-efficiency switching converter, such as a buck switching power supply. The on-state power supply 1420 conducts an on-state charging current  $I_{CHRG-ON}$  to generate the first and second DC supply voltages  $V_{CC1}$ ,  $V_{CC2}$  when the electronic switch 1400 is conductive and the LED light source 104 is on. The on-state power supply 1420 will be described in greater detail below with reference to FIG. 26.

[0160] The digital control circuit 1415 further comprises an analog drive voltage control circuit 1440 for generating the drive voltage  $V_{DR}$  in response to the microprocessor 1430 and the magnitude of the first DC supply voltage  $V_{CC1}$ .

The drive voltage control circuit 1440 comprises a comparator 1442, which compares the magnitude of the first DC supply voltage  $V_{CC1}$  to a reference voltage  $V_{REF}$  (e.g., approximately 8 volts) and generates a power-supply override control signal  $V_{PSO}$ . The drive voltage control circuit 1440 further comprises an AND logic gate 1444 that receives the on-state control signal  $V_{ON}$  from the microprocessor 1430 and the power-supply override control signal  $V_{PSO}$  from the comparator 1442, and generates the drive voltage  $V_{DR}$ . The comparator 1442 and the AND gate 1444 may each be implemented as an integrated circuit or a circuit having discrete parts.

[0161] When the LED light source 104 is off and the on-state control signal  $V_{ON}$ , the AND gate 1444 controls the drive voltage  $V_{DR}$  low, such that the triac 110' is non-conductive and the off-state power supply 1422 generates the first and second DC supply voltages  $V_{CC1}$ ,  $V_{CC2}$ . When the LED light source 104 is on, the on-state power supply 1420 generates the first and second DC supply voltages  $V_{CC1}$ ,  $V_{CC2}$  and is operable to override the on-state control signal  $V_{ON}$  generated by the microprocessor 1430, to thus maintain the triac 110' non-conductive to allow the first DC supply voltage  $V_{CC1}$  to increase to the reference voltage  $V_{REF}$ . Specifically, if the magnitude of the first DC supply voltage  $V_{CC1}$  is less than the reference voltage  $V_{REF}$  when the triac 110' is non-conductive at the beginning of a half-cycle, the comparator 1442 drives the power-supply override control signal  $V_{PSO}$  low, such that the AND gate 1444 also drives the drive voltage  $V_{DR}$  low, thus maintaining the triac 110' non-conductive. Since the triac 110' is non-conductive and there is voltage developed across the on-state power supply 1422, the on-state power supply 1420 is able to charge the first capacitor C1424 while the drive voltage  $V_{DR}$  is low. When the magnitude of the first DC supply voltage  $V_{CC1}$  rises above the reference voltage  $V_{REF}$ , the comparator 1442 drives the power-supply override control signal  $V_{PSO}$  high and the AND gate 1444 drives the drive voltage  $V_{DR}$  high, thus rendering the triac 110' conductive.

[0162] FIG. 26 is a simplified schematic diagram of the on-state power supply 1420. The on-state power supply 1420 comprises a FET Q1470 that is coupled to the rectified bridge 1414 for receiving the rectified voltage  $V_{RECT}$ . The FET Q1470 is operable to conduct the on-state charging current  $I_{CHRG-ON}$  through a resistor R1472 (e.g., having a resistance of approximately 150 mil) and the first capacitor C1424, such that the first DC supply voltage  $V_{CC1}$  is generated across the first capacitor C1424. The on-state power supply 1420 further comprises a regulator circuit 1490, e.g., a linear regulator, for receiving the first DC supply voltage  $V_{CC1}$  and generating the second DC supply voltage  $V_{CC2}$  across the second capacitor C1426.

[0163] The on-state power supply 1420 receives the third DC supply voltage  $V_{CC3}$  (for driving the FET Q1470) as well as the on-state control signal  $V_{ON}$  from the microprocessor 1430. The third DC supply voltage  $V_{CC3}$  is coupled to the gate of the FET Q1470 via a PNP bipolar junction transistor (BJT) Q1474 and two resistors R1475, R1476 (e.g., having resistances of approximately 33 kΩ and 47 kΩ). The gate of the FET Q1470 is coupled to the source of the FET through a resistor R1486 (e.g., having a resistance of approximately 220 kΩ). The second drive voltage  $V_{DR-UP}$  from the microprocessor 1430 is coupled to the base of an NPN bipolar junction transistor Q1480 through a resistor R1482 (e.g., having a resistance of approximately 56.2 kΩ).

The base of the transistor Q1480 is coupled to the emitter through a resistor R1484 (e.g., having a resistance of approximately 56.2 k $\Omega$ ). The collector of the transistor Q1490 is coupled to the base of the transistor Q1474 through a resistor R1485 (e.g., having a resistance of approximately 470 k $\Omega$ ). The base of the transistor Q1474 is further coupled to the emitter through a resistor R1486 (e.g., having a resistance of approximately 100 k $\Omega$ ). The on-state power supply 1420 further comprises an NPN bipolar junction transistor Q1488 having a base-emitter junction coupled across the resistor R1472 and a collector coupled to the junction of the resistors R1475, R1476 to provide overcurrent protection for the FET Q1470.

[0164] When the microprocessor 1430 is controlling the LED light source 104 to be on and the on-state control signal  $V_{ON}$  is high, the base of the transistor Q1474 is pulled down toward circuit common, such that the transistor Q1474 is rendered conductive. Thus, the gate of the FET Q1470 is pulled up towards the third DC supply voltage  $V_{CC3}$ , such that the FET is rendered conductive. When the magnitude of the first DC supply voltage  $V_{CC1}$  is less than the reference voltage  $V_{REF}$ , the triac 110' is maintained non-conductive and the first capacitor C1424 is able to charge through the FET Q1470. When the magnitude of the first DC supply voltage  $V_{CC1}$  rises above the reference voltage  $V_{REF}$ , the triac 110' is rendered conductive, such that the voltage across the on-state power supply drops to approximately zero volts and the first capacitor C1424 stops charging. The first capacitor C1424 will be able to charge again when the triac 110' becomes non-conductive at the end of the half-cycle.

[0165] As shown in FIG. 26, the third DC supply voltage  $V_{CC3}$  is used to drive the FET Q1474 of the on-state power supply 1420. Thus, when the electronic switch 1400 is first powered up, the microprocessor 1430 must wait until the third DC supply voltage  $V_{CC3}$  has increased to an appropriate magnitude (e.g., enough to drive the FET Q1474 on) before allowing the on-state power supply 1420 to generate the first and second DC supply voltages  $V_{CC1}$ ,  $V_{CC2}$ . Specifically, when the electronic switch 1400 is powered up and the LED light source 104 should be on, the microprocessor 1430 is operable to maintain the LED light source 104 off for a predetermined amount of time to allow the off-state power supply to increase the magnitude of third DC supply voltage  $V_{CC3}$  to the appropriate magnitude before rendering the triac 110' conductive.

[0166] While the twelfth embodiment has been described with reference to the electronic switch 1400, the on-state power supply 1420 and the analog drive voltage control circuit 1440 could be used in other types of load control devices, such as, for example, dimmer switches.

[0167] FIG. 27 is a simplified block diagram of a load control device, e.g., a dimmer switch 1500, according to a thirteenth embodiment of the present invention. The dimmer switch 1500 comprises a full-wave rectifier bridge 1514 (including four diodes D1514A, D1514B, D1514C, D1514D) that has AC terminals coupled in series between a hot terminal H and a dimmed hot terminal DH, and DC terminals for providing a rectified voltage  $V_{RECT}$  to a digital control circuit 1515. The digital control circuit 1515 comprises a microprocessor 1530 that is coupled to the gate of the triac 110' via a gate coupling circuit 1550. The dimmer switch 1500 may comprise one or more actuators 1536 for receiving user inputs and a zero-cross detect circuit 1534 for generating a zero-cross voltage  $V_{ZC}$  representative of the

zero-crossing of the AC line voltage  $V_{AC}$ . The microprocessor 1530 is operable to render the triac 110' conductive in response to the zero-cross detect circuit 1534 and the actuators 1536. The dimmer switch 1500 further comprises a resistor 1554 (e.g., having a resistance of approximately 30-47 $\Omega$ ) coupled between the gate of the triac 110' and the dimmed hot terminal DH (i.e., the second main load terminal of the triac 110).

[0168] The gate coupling circuit 1550 comprises a single MOS-gated transistor, e.g., a FET Q1552, inside of a full-wave rectifier bridge that includes diodes D1556A-D1556D (as well as the diode D1514D). Specifically, the FET Q1552 is coupled across the DC terminals of the full-wave rectifier bridge, while the AC terminals are coupled between the hot terminal H and the gate of the triac 110'. The gate coupling circuit 1550 receives a drive voltage  $V_{DR}$  from the digital control circuit 1515, and the drive voltage  $V_{DR}$  is coupled to the gate of the FET Q1552 via a gate drive circuit 1560. When the FET Q1552 is rendered conductive, a gate current  $I_G$  may be conducted through the FET Q1552, the diodes D1556A, D1556D, and the gate of the triac 110' during the positive half-cycles to render the triac conductive. During the negative half-cycles, the gate current  $I_G$  may be conducted through the gate of the triac 110', the FET Q1552, and the diodes D1556B, D1556C and the diode D1514D. While not shown as such in FIG. 27, the diode D1556B may comprise four diodes coupled in series to ensure that the diode D1556D is forward biased during the positive half-cycles.

[0169] The digital control circuit 1515 also comprises a power supply 1520 for generating a first DC supply voltage  $V_{CC1}$  (e.g., approximately 2.8 volts) for powering the microprocessor 1530 and a boosting power supply, e.g., a boost converter 1528, which receives the first DC supply voltage  $V_{CC1}$  and generates a second boosted DC supply voltage  $V_{CC2}$  (e.g., approximately 15 volts) for driving the FET Q1552 of the gate coupling circuit 1550.

[0170] The dimmer switch 1500 further comprises a controllable switching circuit 1580 coupled to the DC terminals of the full-wave rectifier bridge 1514, such that the controllable switching circuit 1580 is coupled in parallel electrical connection with the triac 110' and provides an alternate current path for the load current  $I_{LOAD}$  to flow when the triac is non-conductive. The microprocessor 1530 generates a load-current-path control voltage  $V_{LCP}$  for rendering the controllable switching circuit 1580 conductive and non-conductive. For example, the controllable switching circuit 1580 may comprise a field-effect transistor (FET) or other suitable semiconductor switch or switching circuit coupled across the DC terminals of the full-wave rectifier bridge 1514. The controllable switching circuit 1580 may also comprise a drive circuit (not shown) for providing the second DC supply voltage  $V_{CC2}$  to the gate of the FET for rendering the FET conductive in response to the load-current-path control voltage  $V_{LCP}$ . Alternatively, the controllable circuit 1580 could comprise a bidirectional semiconductor switch (such as a triac or two FETs in anti-series connection) or other suitable switching circuit coupled across the AC terminals of the full-wave rectifier bridge 1514.

[0171] FIG. 28 shows example waveforms illustrating the operation of the dimmer switch 1500 according to the thirteenth embodiment of the present invention. The microprocessor 1530 drives the drive voltage  $V_{DR}$  high towards

the first DC supply voltage  $V_{CC1}$  to render the gate coupling circuit **1580** conductive at the firing time (e.g., at time  $t_1$  in FIG. **28**) each half-cycle to conduct the gate current  $I_G$  through the gate of the triac to thus render the triac **110'** conductive. The microprocessor **1530** maintains drive voltage  $V_{DR}$  high to keep the gate coupling circuit **1580** conductive after the firing time  $t_1$  until a transition time (e.g., at time  $t_2$ ) before the next zero-crossing (e.g., 600 microseconds before the next zero-crossing). Since the gate coupling circuit **1580** is rendered non-conductive before the end of the half-cycle, the triac **110'** is able to commutate off when the magnitude of the load current  $I_{LOAD}$  drops below the rated holding current of the triac. The triac **110'** cannot be rendered conductive again during the present half-cycle and will remain non-conductive at the beginning of the next half-cycle.

[0172] The microprocessor **1530** also drives the load current path control voltage  $V_{LCP}$  high to render the controllable switching circuit **1280** conductive at approximately the transition time  $t_2$ , such that the controllable switching circuit is able to conduct the load current  $I_{LOAD}$  if the triac **110'** commutates off before the end of the half-cycle. For example, the microprocessor **1530** may drive the load current path control voltage  $V_{LCP}$  high before controlling the drive voltage  $V_{DR}$  low to render the gate coupling circuit **1580** non-conductive (e.g., approximately 10 microseconds before driving the drive voltage  $V_{DR}$  low) to ensure that the controllable switching circuit **1280** is conductive before the triac **110'** commutates off. The microprocessor **1530** then drives the load current path control voltage  $V_{LCP}$  low to render the controllable switching circuit **1280** non-conductive at the end of the half-cycle (e.g., at time  $t_3$  in FIG. **28**).

[0173] Accordingly, in the dimmer switch **1500**, the gate current  $I_G$  is able to be conducted through a first current path (e.g., the FETs **Q1552A**, **Q1552B** of the gate coupling circuit **1550**) between the firing time  $t_1$  and the transition time  $t_2$  before the end of the half-cycle when the FETs **Q1552A**, **Q1552B** are rendered non-conductive. In addition, the load current  $I_{LOAD}$  is able to be conducted through a second current path (e.g., the controllable switching circuit **1580** and the full-wave rectifier bridge **1514**) when the triac **110'** commutates off near the end of the half-cycle (e.g., after the transition time  $t_2$  when the FETs **Q1552A**, **Q1552B** are rendered non-conductive) until the end of the half-cycle (e.g., at time  $t_3$  when the controllable switching circuit **1580** is rendered non-conductive).

[0174] The dimmer switch **1500** comprises two independently-controllable paths for the load current  $I_{LOAD}$  to flow. Specifically, the dimmer switch **1500** comprises a first load-current path having a latching behavior (e.g., the triac **110'**) that is able to conduct the load current  $I_{LOAD}$  between the firing time  $t_1$  until the triac commutates off near the end of the half-cycle (e.g., after the transition time  $t_2$ ). The dimmer switch **1500** comprises a second load-current path (e.g., the controllable switching circuit **1580** and the full-wave rectifier bridge **1514**) that is able to conduct the load current  $I_{LOAD}$  when the triac **110'** commutates off near the end of the half-cycle (e.g., after the transition time  $t_2$  when the FETs **Q1552A**, **Q1552B** of the gate coupling circuit **1550** are rendered non-conductive) until the end of the half-cycle. The second load-current path may be characterized in having a non-latching behavior, such that conduction of current through the second load-current path may be started and

stopped in response to one or more control signals (e.g., the load current path control voltage  $V_{LCP}$ ).

[0175] While the present invention has been described with reference to the high-efficiency lighting load **101** having the LED driver **102** for controlling the intensity of the LED light source **104**, the dimmer switches **100**, **200**, **300**, **400**, **500**, **600**, **700**, **800**, **900**, **1200**, **1300**, **1500** and the electronic switch **1400** could be used to control the amount of power delivered to other types of lighting loads (such as incandescent lamps, halogen lamps, magnetic low-voltage lamps, electronic low-voltage lamps), other types of electrical loads (such as motor and fan loads), and other types of load regulation devices (such as electronic dimming ballasts for fluorescent lamps).

[0176] This application is related to commonly-assigned U.S. patent application Ser. No. 12/953,057, filed Nov. 23, 2010, entitled TWO-WIRE ANALOG FET-BASED DIMMER SWITCH, the entire disclosure of which is hereby incorporated by reference.

[0177] Although the present invention has been described in relation to particular embodiments thereof, many other variations and modifications and other uses will become apparent to those skilled in the art. It is preferred, therefore, that the present invention be limited not by the specific disclosure herein, but only by the appended claims.

What is claimed is:

1. A dimmer switch for controlling an amount of power delivered from an AC power source to a lighting load for controlling an intensity of the lighting load, the dimmer switch comprising:

- a triac adapted to be electrically coupled between the AC power source and the lighting load, the triac having first and second main terminals through which current can be conducted to energize the lighting load and a gate terminal through which current can be conducted to render the triac conductive between the first and second main terminals;
- a first circuit electrically coupled between the first main terminal of the triac and the gate terminal of the triac to conduct current through the gate terminal of the triac;
- a second circuit electrically coupled between the first and second main terminals of the triac to conduct current through the lighting load when the triac is non-conductive; and
- a control circuit configured to individually control the first and second circuits to be conductive and non-conductive, the control circuit configured to render the first circuit conductive to conduct a pulse of current through the gate terminal of the triac at a firing time during a present half-cycle of the AC power source to render the triac conductive, the control circuit configured to control the firing time to adjust the intensity of the lighting load;

wherein the control circuit is configured to control the first circuit to allow the first circuit to conduct at least one other pulse of current through the gate terminal of the triac after the firing time during the present half-cycle, the control circuit configured to render the first circuit non-conductive before the end of the present half-cycle to prevent any further pulses of current from being thereafter conducted through the gate terminal of the triac during the present half-cycle, the control circuit further configured to control the second circuit to

conduct current through the lighting load after the first circuit is rendered non-conductive.

2. The dimmer switch of claim 1, wherein the first circuit includes a gate coupling circuit and a controllable switching circuit electrically coupled in series between the first main terminal of the triac and the gate terminal of the triac for conducting current through the gate terminal of the triac when the gate coupling circuit and the controllable switching circuit are conductive.

3. The dimmer switch of claim 2, wherein the second circuit includes the gate coupling circuit and a resistor, the gate coupling circuit electrically coupled between the first main terminal of the triac and the controllable switching circuit, the resistor electrically coupled between the second main terminal of the triac and the junction of the gate coupling circuit and the controllable switching circuit, the resistor configured to conduct current through the lighting load when the triac is non-conductive.

4. The dimmer switch of claim 3, wherein the gate coupling circuit comprises two MOS-gated transistors electrically coupled in anti-series connection between the first main terminal and the gate terminal of the triac.

5. The dimmer switch of claim 4, wherein the control circuit is configured to generate a single drive signal for controlling the gate coupling circuit, the gate coupling circuit comprising a control input electrically coupled to receive the single drive signal from the control circuit.

6. The dimmer switch of claim 5, wherein the gate coupling circuit is configured such that the control input conducts an average current of less than one microamp to maintain the gate coupling circuit conductive between the firing time and the end of the present half-cycle.

7. The dimmer switch of claim 5, wherein the gate coupling circuit is configured to conduct through the control input an amount of current appropriate to charge input capacitances of gate terminals of the MOS-gated transistors when the MOS-gated transistors are rendered conductive at the firing time.

8. The dimmer switch of claim 4, wherein the control circuit is configured to generate two drive signals and to apply the two drive signals to respective ones of the MOS-gated transistors to independently control the MOS-gated transistors.

9. The dimmer switch of claim 8, wherein the control circuit is configured to render both of the MOS-gate transistors conductive at the firing time, the control circuit being further configured to render a first one of the MOS-gated transistors non-conductive prior to the end of the present half-cycle to block current at the beginning of the next half-cycle, and to render a second one of the MOS-gated transistors non-conductive after the end of the present half-cycle to conduct current through the lighting load until the end of the present half-cycle.

10. The dimmer switch of claim 8, wherein the gate coupling circuit comprises two control inputs for receiving the respective drive signals from the control circuit, the gate coupling circuit being configured to conduct through each of the control inputs an amount of current appropriate to charge an input capacitance of a gate terminal of the respective MOS-gated transistor when the MOS-gated transistors are rendered conductive at the firing time.

11. The dimmer switch of claim 4, wherein the control circuit comprises a microprocessor and a power supply configured to generate a DC supply voltage to power the

microprocessor so that the control circuit is able to render the MOS-gated transistors of the gate coupling circuit non-conductive.

12. The dimmer switch of claim 3, wherein the control circuit is configured to control the gate coupling circuit to allow the gate coupling circuit to conduct the at least one other pulse of current between the firing time and a second time that occurs after the firing time and before the end of the present half-cycle, the control circuit being configured to render the controllable switching circuit non-conductive at the second time in order to prevent the gate coupling circuit from conducting another pulse of current to thereby allow the triac to become non-conductive.

13. The dimmer switch of claim 12, wherein the gate coupling circuit is electrically coupled to conduct current through the lighting load when the triac becomes non-conductive after the second time.

14. The dimmer switch of claim 3, wherein the control circuit is configured to render the controllable switching circuit conductive and to control the gate coupling circuit to conduct the pulse of current through the gate terminal of the triac at the firing time to render the triac conductive, the control circuit being configured to control the gate coupling circuit to allow the gate coupling circuit to conduct the at least one other pulse of current through the gate terminal of the triac after the firing time during the present half-cycle, the control circuit being further configured to render the controllable switching circuit non-conductive before the end of the present half-cycle to prevent any further pulses of current from being thereafter conducted through the gate terminal of the triac during the present half-cycle.

15. The dimmer switch of claim 14, wherein the triac is able to commutate off after the control circuit renders the controllable switching circuit non-conductive, the control circuit being further configured to maintain the controllable switching circuit non-conductive until at least the beginning of the next half-cycle of the AC power source, thereby assuring that the triac remains non-conductive for the remainder of the present half-cycle after the triac commutates off.

16. The dimmer switch of claim 3, wherein the dimmer switch arranged such that a combination of the triac and the gate coupling circuit is able to conduct current through the lighting load independent of a rated holding current of the triac.

17. The dimmer switch of claim 1, further comprising:  
a wireless signal receiver configured to receive a wireless signal;

wherein the control circuit is configured to determine a desired intensity for the lighting load in response to the wireless signal.

18. The dimmer switch of claim 17, wherein the wireless signal receiver comprises a radio-frequency receiver configured to receive a radio-frequency signal.

19. The dimmer switch of claim 1, further comprising:  
an intensity adjustment actuator configured to receive a user input;

wherein the control circuit is configured to determine a desired intensity for the lighting load in response to actuations of the intensity adjustment actuator.

20. The dimmer switch of claim 1, further comprising:  
a power supply electrically coupled to conduct current through the lighting load to generate a supply voltage for powering the control circuit.

**21.** The dimmer switch of claim **1**, wherein the control circuit is configured to control the first and second circuits to prevent the triac from being rendered conductive again after the first circuit is rendered non-conductive until the end of the present half-cycle.

**22.** The dimmer switch of claim **1**, wherein the control circuit is configured to control the first and second circuits to ensure that the triac remains non-conductive for the remainder of the present half-cycle after the triac commutates off.

\* \* \* \* \*