

July 29, 1930.

J. CAVANAGH

1,771,706

BOX

Filed May 11, 1928

2 Sheets-Sheet 1

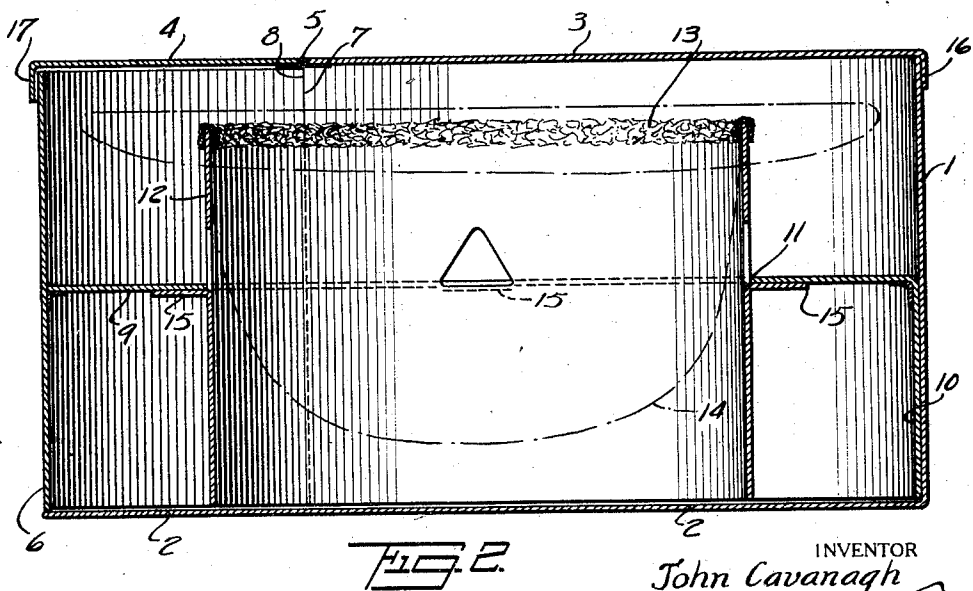
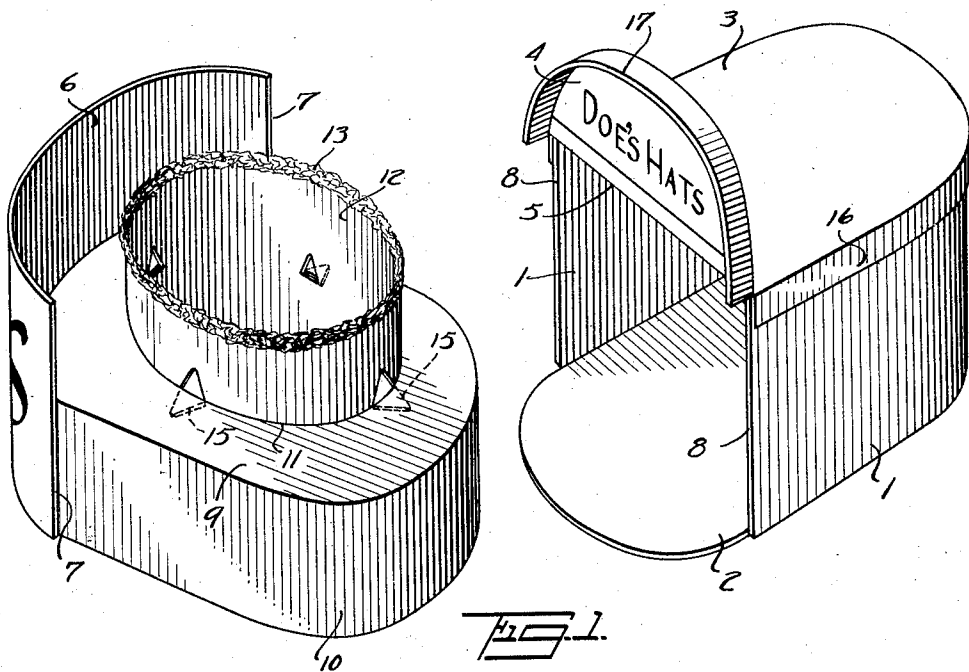

INVENTOR  
*John Cavanagh*  
BY  
*Wm Wallace White*  
ATTORNEY

July 29, 1930.

J. CAVANAGH

1,771,706

BOX

Filed May 11, 1928

2 Sheets-Sheet 2

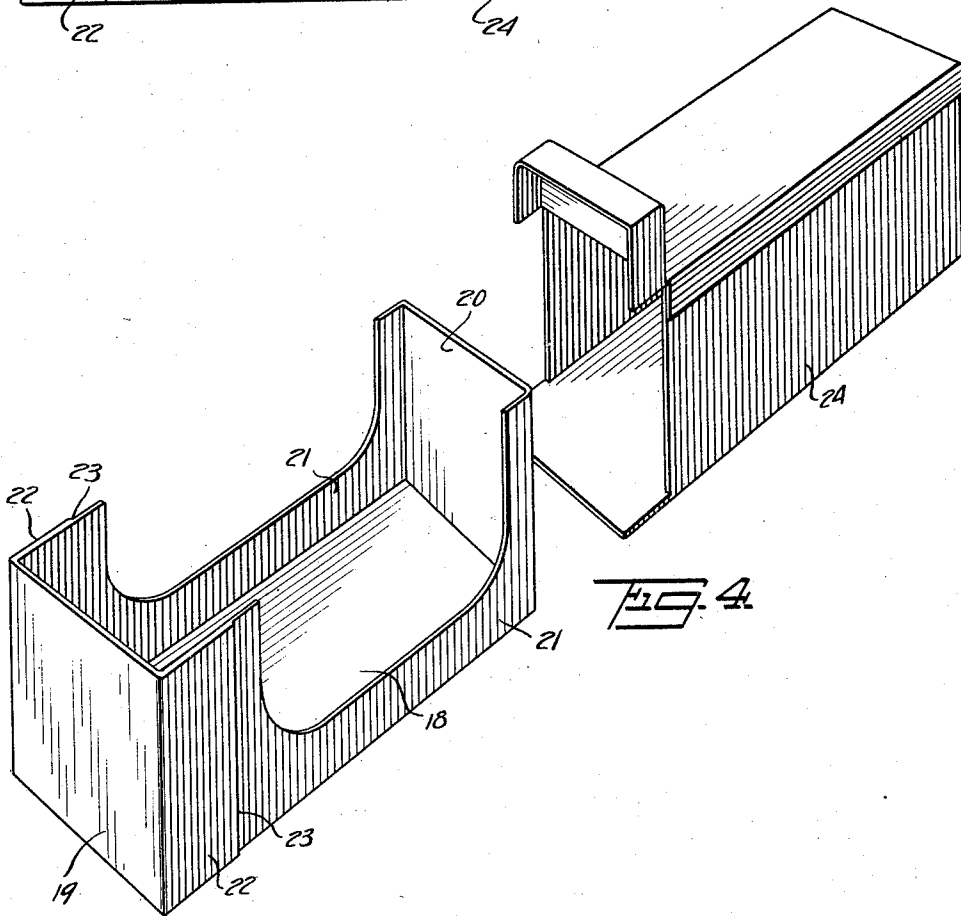
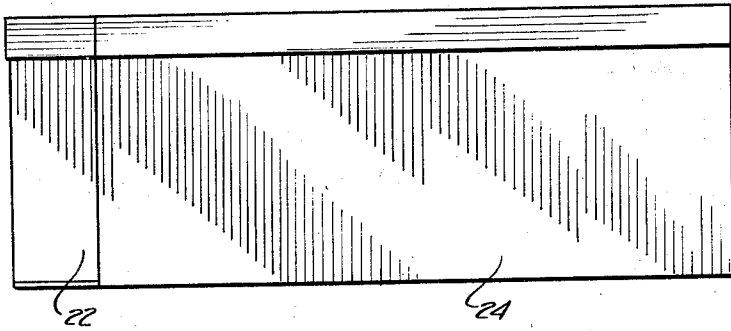

INVENTOR  
*John Cavanagh*  
BY  
*Wm Wallace White*  
ATTORNEY

## UNITED STATES PATENT OFFICE

JOHN CAVANAGH, OF SOUTH NORWALK, CONNECTICUT

## BOX

Application filed May 11, 1928. Serial No. 277,064.

This invention relates to boxes for use in holding hats, gloves, shoes and other goods and relates more particularly to cardboard or paper-board boxes of the kind commonly used in wholesale stores and retail shops for holding such goods.

One object of my present invention is to provide an improved cardboard or paper-board box having a drawer portion and improved means for normally retaining such drawer portion in an outer shell or container.

A further object of this invention is to provide a hat box having a drawer or slide portion with improved means for carrying the hat.

With these and other objects in view the invention consists in the novel construction hereinafter described, illustrated in the accompanying drawings and particularly pointed out in the appended claims, it being understood that various changes in the form, material and details of constructions may be made without departing from the spirit of the invention or sacrificing any of the advantages thereof.

In the drawings: Fig. 1 is a perspective view of a hat box made in accordance with my invention and with the drawer or slide portion removed from the outer shell or casing; Fig. 2 is a vertical longitudinal section of the closed box; Fig. 3 is a side elevation of a modified box particularly adapted for holding shirts, gloves, shoes or like goods and Fig. 4 is a perspective view showing the box with the inner slide portion removed from the outer shell portion or casing.

Referring to Figs. 1 and 2 the hat box has an outer shell or casing comprising a side wall 1, a bottom 2, a fixed cover part 3 and a movable cover part 4 which latter is hinged to the part 3 along the line 5.

The drawer or slide portion of the box comprises a front wall 6 having side edges 7 adapted to engage the side edges 8 of the wall 1 of the shell part when the box is closed. Secured to the front wall 6 is a horizontal partition wall 9 having a depending rim portion 10 adapted to bear upon the bottom 2 of the shell part when the box is closed and mounted in a central opening 11, in the part

9, is a hat carrying ring 12 whose lower edge may rest upon the bottom 2 and whose upper edge is provided with an annular padding 13 for the reception of the brim of an inverted hat 14. In the construction shown the ring part 12 is secured to the part 9 by means of tongue pieces 15 stamped out from the part 12 and secured by suitable adhesive to the underside of the part 9. The fixed cover part 3 is provided with a depending rim 16 which is permanently secured to the side wall 1 of the shell, and the hinged portion 4 of the cover has a similar depending rim 17 which is adapted to engage over the outer surface of the wall 6 when the drawer or slide portion is in position in the shell.

The front surface of the wall 6 may bear the name of the manufacturer or dealer or of the goods or similar advertising matter and the under-surface of the hinged part 4 of the cover may also bear suitable information or advertising matter adapted to be exposed when the hinged part of the cover is raised into the position shown at Fig. 1.

The box shown at Figs. 1 and 2 is of the ordinary hat box shape with rounded ends and the box shown at Figs. 3 and 4 is of rectangular form and it will of course be understood that the particular shape of the box and the proportions thereof may be modified to suit the particular goods to be contained therein.

In the form shown at Figs. 3 and 4 the shell or outer casing 24 is similar to that shown at Figs. 1 and 2 except that the corners are square. The drawer or slide portion, however, comprises a bottom 18, front and back walls 19 and 20 and side walls 21 which latter are cut away or recessed to facilitate the removal of the contents. The front part of the side walls 21 of the slide portion are thickened at 22 so as to present shoulders or edges 23 adapted to engage the front edges of the side walls of the shell part 24 to present flush outer side walls on the closed box.

Although the drawings and the above specification disclose the best mode in which I have contemplated embodying my invention, I desire it to be understood that the form and construction may be varied as circum-

stances may require or experience suggest without departing from the spirit of the invention within the scope of the appended claims.

What I claim is:

5 1. A box of the character described comprising an outer shell member, hinged and fixed cover portions thereon, a shallow rim depending from the hinged cover portion,  
10 and an inner slide member comprising a front part adapted to be engaged by said rim when the box is closed and having vertical side edges or shoulders to engage the front edges of the said shell portion.

15 2. A box of the character described comprising an outer shell member, a hinged and a fixed cover portion thereon, shallow depending rim parts depending from said cover portions in imitation of a removable lid, and  
20 an inner slide member comprising a front part having vertical side edges or shoulders to closely engage the front edges of the said shell portion, the upper edge of said front part being engaged by the depending rim part on the hinged cover portion when the  
25 box is closed.

3. A box of the character described comprising flush vertical walls having side joints therein, an inner slide portion formed on the  
30 front section of said walls, an outer shell portion comprising the rear section of said walls, and a hinged lid portion having a shallow depending rim for engaging the upper part of the front section of said walls to retain  
35 the inner slide portion in the outer shell portion without concealing the front part of said walls.

In testimony whereof I have signed my name to this specification.

40 JOHN CAVANAGH.

45

50

55

60

65