

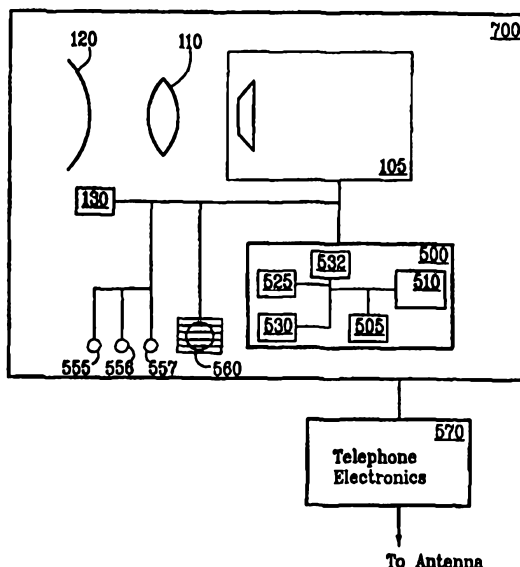

INTERNATIONAL APPLICATION PUBLISHED UNDER THE PATENT COOPERATION TREATY (PCT)

<p>(51) International Patent Classification <sup>6</sup> : G06K 9/00, H04K 1/00, H04L 9/00, G07D 7/00</p>	<p>A1</p>	<p>(11) International Publication Number: <b>WO 00/31679</b> (43) International Publication Date: 2 June 2000 (02.06.00)</p>
<p>(21) International Application Number: PCT/US99/26559 (22) International Filing Date: 10 November 1999 (10.11.99) (30) Priority Data: 09/199,369 25 November 1998 (25.11.98) US 09/310,302 12 May 1999 (12.05.99) US (71) Applicant: IRISCAN, INC. [US/US]; Suite E, 9 East Stow Road, Marlton, NJ 08053-3159 (US). (72) Inventors: MUSGRAVE, Clyde; 3620 Fairfield Place, Frisco, TX 75035 (US). CAMBIER, James, L.; 10 Holly Drive, Medford, NJ 08055 (US). (74) Agents: DONOHUE, John, P., Jr. et al.; Woodcock Washburn Kurtz Mackiewicz &amp; Norris LLP, 46th floor, One Liberty Place, Philadelphia, PA 19103 (US).</p>		<p>(81) Designated States: AE, AL, AM, AT, AU, AZ, BA, BB, BG, BR, BY, CA, CH, CN, CR, CU, CZ, DE, DK, DM, EE, ES, FI, GB, GD, GE, GH, GM, HR, HU, ID, IL, IN, IS, JP, KE, KG, KP, KR, KZ, LC, LK, LR, LS, LT, LU, LV, MA, MD, MG, MK, MN, MW, MX, NO, NZ, PL, PT, RO, RU, SD, SE, SG, SI, SK, SL, TJ, TM, TR, TT, TZ, UA, UG, UZ, VN, YU, ZA, ZW, ARIPO patent (GH, GM, KE, LS, MW, SD, SL, SZ, TZ, UG, ZW), Eurasian patent (AM, AZ, BY, KG, KZ, MD, RU, TJ, TM), European patent (AT, BE, CH, CY, DE, DK, ES, FI, FR, GB, GR, IE, IT, LU, MC, NL, PT, SE), OAPI patent (BF, BJ, CF, CG, CI, CM, GA, GN, GW, ML, MR, NE, SN, TD, TG).</p> <p><b>Published</b> <i>With international search report.</i></p>

(54) Title: IRIS IMAGING TELEPHONE SECURITY MODULE AND METHOD



(57) Abstract

A compact handheld imaging apparatus (700) which can be used to capture high-quality iris images for identification of a person. The handheld iris imager is non-invasive and non-contacting and comprises a camera (105), a cold mirror (120), a lens (110), and an illuminator (130). The imager has sensors and indicators (555, 556, 557, 560) which assist a user in aligning and focusing the device. The imager also automatically captures the image when proper positioning is achieved. A template of the image is then compared to a database of previously stored templates of images to identify the person. The imager is integrated into a telecommunications device as a security module. The telecommunications device cannot be unlocked and used unless a user has been identified and authorized by the imager.

**FOR THE PURPOSES OF INFORMATION ONLY**

Codes used to identify States party to the PCT on the front pages of pamphlets publishing international applications under the PCT.

AL	Albania	ES	Spain	LS	Lesotho	SI	Slovenia
AM	Armenia	FI	Finland	LT	Lithuania	SK	Slovakia
AT	Austria	FR	France	LU	Luxembourg	SN	Senegal
AU	Australia	GA	Gabon	LV	Latvia	SZ	Swaziland
AZ	Azerbaijan	GB	United Kingdom	MC	Monaco	TD	Chad
BA	Bosnia and Herzegovina	GE	Georgia	MD	Republic of Moldova	TG	Togo
BB	Barbados	GH	Ghana	MG	Madagascar	TJ	Tajikistan
BE	Belgium	GN	Guinea	MK	The former Yugoslav Republic of Macedonia	TM	Turkmenistan
BF	Burkina Faso	GR	Greece			TR	Turkey
BG	Bulgaria	HU	Hungary	ML	Mali	TT	Trinidad and Tobago
BJ	Benin	IE	Ireland	MN	Mongolia	UA	Ukraine
BR	Brazil	IL	Israel	MR	Mauritania	UG	Uganda
BY	Belarus	IS	Iceland	MW	Malawi	US	United States of America
CA	Canada	IT	Italy	MX	Mexico	UZ	Uzbekistan
CF	Central African Republic	JP	Japan	NE	Niger	VN	Viet Nam
CG	Congo	KE	Kenya	NL	Netherlands	YU	Yugoslavia
CH	Switzerland	KG	Kyrgyzstan	NO	Norway	ZW	Zimbabwe
CI	Côte d'Ivoire	KP	Democratic People's Republic of Korea	NZ	New Zealand		
CM	Cameroon			PL	Poland		
CN	China	KR	Republic of Korea	PT	Portugal		
CU	Cuba	KZ	Kazakstan	RO	Romania		
CZ	Czech Republic	LC	Saint Lucia	RU	Russian Federation		
DE	Germany	LI	Liechtenstein	SD	Sudan		
DK	Denmark	LK	Sri Lanka	SE	Sweden		
EE	Estonia	LR	Liberia	SG	Singapore		

## **IRIS IMAGING TELEPHONE SECURITY MODULE AND METHOD**

### **RELATED APPLICATION DATA**

The present application is a continuation-in-part application of U.S. Patent Application Serial Number 09/199,369, having a filing date of November 25, 1998.

### **5 FIELD OF THE INVENTION**

The present invention relates in general to identification of physical characteristics of a human being or other animal. More particularly, the present invention relates to iris recognition.

### **BACKGROUND OF THE INVENTION**

10 Various technologies are used for uniquely identifying a person in accordance with an examination of particular attributes of either the person's interior or exterior eye. One of these technologies involves the visual examination of the particular attributes of the exterior of the iris of at least one of the person's eyes. The iris of the human eye has random patterns of striations, ciliary processes, crypts, rings, furrows and other features  
15 which had been shown capable of generating highly unique biometric templates for personal identification. In this regard, reference is made to U.S. Patent No. 4,641,349, "Iris Recognition System", issued to Flom et al., and U.S. Patent No. 5,291,560, "Biometric Personal Identification System Based on Iris Analysis", issued to Daugman. As made clear

by these patents, the visible texture of a person's iris can be used to distinguish one person from another with great accuracy. Thus, iris recognition can be used for such purposes as controlling access to a secure facility or a bank automatic teller machine, for example. An iris recognition system involves the use of an imager to video image the iris of each person  
5 attempting access, and image processing means for comparing this iris video image with a reference iris image on file in a database.

Iris identification systems have been developed that are capable of collecting images of the iris and processing them to produce biometric templates. These templates may be used to identify individual irises with extremely low error rates, on the order of 1  
10 in  $10^{78}$ . The systems capture the iris images using stationary optical platforms that are often large, complex, and expensive. The systems are difficult to use with minimal cooperation of the subject being identified. As a result their usefulness in many applications is limited.

The cellular telephone industry each year loses an estimated \$650 million to cellular fraud, principally due to cloning of cellular telephones. Cloning involves re-  
15 programming a phone's electronic serial number and telephone number to those stolen from a legitimate subscriber. To counteract cloning, some service providers have utilized personal authentication techniques such as personal identification numbers (PIN) or voice verification to verify that the authorized subscriber is using the phone. This is unreliable because PIN number can be stolen or forgotten, and voice verification messages may be  
20 recorded.

Although the art of human recognition systems is well developed, there remain some problems inherent in this technology, particularly the lack of an iris imager and security module suitable for integration into a cellular telephone, and the lack of a method for using biometric information for enabling access to the cellular network.  
25 Therefore, a need exists for a recognition system that overcomes the drawbacks of the prior art.

## **SUMMARY OF THE INVENTION**

The present invention is directed to a telecommunications device comprising  
30 a telephone security module comprising: iris acquisition means having a front surface for obtaining an image of an iris of an eye; a lens having a image plane disposed in front of the

front surface of the iris acquisition means; a mirror disposed on a side of the lens opposite the iris acquisition means; an illuminator disposed along a side of the mirror; a memory for storing an iris image obtained by the iris acquisition means; a processor for extracting a template from the stored iris image; and a communications interface for transmitting the  
5 template to a central station.

According to one aspect of the invention, the iris acquisition means comprises a camera, and the mirror is a cold mirror. The camera is sensitive to light having a wavelength in a range between about 400 nm and about 1100 nm. The mirror reflects light having a wavelength in a range between about 400 nm and about 700 nm and  
10 passes light having a wavelength greater than about 700 nm.

According to another aspect of the present invention, the illuminator emits light having a wavelength in a range between about 680 nm and about 900 nm towards the iris of the eye being imaged, and the eye is out of contact with the iris imaging apparatus.

According to another aspect of the present invention, the module further  
15 comprises at least a visible indicator or an audible indicator to indicate when the image of the iris has been obtained. According to another aspect of the present invention, the module further comprises a focus assessment processor coupled to the visible indicator and/or the audible indicator.

According to another aspect of the present invention, the processor unlocks  
20 a telecommunications device responsive to a signal received from the central station.

In a further embodiment within the scope of the present invention, a method of unlocking a telecommunications device responsive to the identification of a person comprises the steps of: (a) storing image information of the iris of at least one person's eye; (b) illuminating an eye of an unidentified person having an iris; (c) obtaining an image of  
25 the iris of the unidentified person; (d) determining if the image is an image of sufficient quality for a step (f) of extracting; (e) repeating steps (b) through (d) until the image of sufficient quality is obtained; (f) extracting an iris template if the image is of sufficient quality; (g) comparing the template of the obtained image with the stored image information to identify the unidentified person; and (h) unlocking the telecommunications device  
30 responsive to a result of the step of comparing. The stored image information used for

identification can be a code or template extracted from the image, and the comparison can be performed at a central database maintained by a telephone service provider.

According to one aspect of the present invention, the method further comprises the step of activating an indicator if the image is of insufficient quality. The  
5 indicator is an audible indicator.

According to another aspect of the present invention, the method further comprises the step of activating an indicator if the image is of sufficient quality. The indicator is a visible indicator.

According to another aspect of the present invention, the method further  
10 comprises the step of activating an indicator responsive to the step of comparing. The indicator is a visible indicator.

In accordance with a further aspect of the present invention, the step of determining if the image is an image of sufficient quality comprises the step of focus assessment processing the image.

According to another aspect of the present invention, the telecommunications  
15 device is unlocked if the step of comparing identifies the person.

In a further embodiment within the scope of the present invention, a telecommunications device comprises a telephone security module comprises: iris acquisition means having a front surface for obtaining an image of an iris of an eye; a lens  
20 having a image plane disposed in front of the front surface of the iris acquisition means; a mirror disposed on a side of the lens opposite the iris acquisition means; an illuminator disposed along a side of the mirror; a first memory for storing at least one template of at least one image of an iris of at least one person's eye; a second memory for storing an iris image obtained by the iris acquisition means; a processor for extracting a template from the  
25 stored iris image; and a comparator for comparing the template from stored iris image with the at least one template to identify the person.

In another embodiment within the scope of the present invention, a telecommunications device having telephone electronics comprises a telephone security module. The telecommunications device is unlocked if an iris template of an iris image  
30 identifies the person having the iris.

**BRIEF DESCRIPTION OF THE DRAWINGS**

The foregoing and other aspects of the present invention will become apparent from the following detailed description of the invention when considered in conjunction with the accompanying drawings. For the purpose of illustrating the invention, 5 there is shown in the drawings an embodiment that is presently preferred, it being understood, however, that the invention is not limited to the specific methods and instrumentalities disclosed. In the drawings:

Fig. 1 is a schematic diagram of an exemplary iris imager in accordance with the present invention;

10 Fig. 2A is a schematic diagram of the imager of Fig. 1 shown in greater detail;

Fig. 2B is a schematic diagram of another exemplary imager in accordance with the present invention;

15 Fig. 3 is a simplified flowchart of a method of operation in accordance with the present invention;

Fig. 4 is a schematic diagram of an exemplary iris image recognition system in accordance with the present invention;

Fig. 5 is a schematic diagram of an exemplary iris imager having visual and aural indicators in accordance with the present invention;

20 Fig. 6 is a more detailed flow chart of a method of operation in accordance with the present invention;

Fig. 7 is a schematic diagram of an exemplary iris image recognition system having a focus assessment processor in accordance with the present invention;

25 Fig. 8 is a schematic diagram of an exemplary iris imager incorporated into a telephone in accordance with the present invention;

Fig. 9A is an isometric view of an exemplary telecommunications iris imager and telephone in accordance with the present invention;

Figs. 9B, 9C, and 9D show rear, side, and front elevational views of another exemplary device in which the imager of the present invention can be incorporated;

30 Fig. 10 is a flow diagram of an exemplary method of operation of a telecommunications iris imager in accordance with the present invention; and

Fig. 11 is a diagram of a phone and communications server in communication with each other in accordance with the present invention.

### DESCRIPTION OF EXEMPLARY EMBODIMENTS AND BEST MODE

The present invention is directed to a compact, handheld imaging apparatus and method which can be used to capture high-quality iris images. Preferably, the imager has sensors and indicators which assist the human operator in aligning and focusing the device. The imager also automatically captures the image when proper positioning is achieved. Because it is small and compact, it is practical for integration into a cellular telephone where it is used to authenticate telephone subscribers and eliminate cellular telephone fraud. Throughout the following detailed description similar reference numbers refer to similar elements in the figures of the drawings.

Fig. 1 illustrates a preferred embodiment of the handheld imager 100 in accordance with the present invention. The exemplary handheld, non-invasive, non-contacting iris imager comprises iris acquisition means 105, an imaging lens 110, a mirror 120, an optional diopter correction lens 125, and an illuminator 130. The imager 100 is preferably powered by a standard DC supply provided by a cellular telephone.

The iris acquisition means 105 is preferably a conventional solid state video camera, such as a charged coupled device (CCD) or complementary metal oxide semiconductor (CMOS) device. A preferred camera is a 1/3 inch format, monochrome CCD board camera, such as Computar Model EM200. Preferably, the video camera 105 is sensitive to light of wavelengths in the range of about 400 nanometers to about 1100 nanometers, and is positioned so that its front surface coincides with the image plane of the lens 110 in front of it. In the preferred embodiment, the object plane of the lens is approximately 89 mm in front of the lens 110. More preferably, the lens 110 is an optical lens with approximately 14.2 mm focal length.

The mirror 120, preferably a concave cold mirror having a radius of curvature preferably about 276 mm, is disposed on the side of the lens 110 opposite the video camera 105 and creates a magnified virtual image of the iris behind the mirror 120. In the preferred embodiment, the mirror 120 reflects visible light with wavelengths in the



range of about 400 to about 700 nanometers, and passes light having longer wavelengths, such as those in the range of about 700 to about 900 nanometers.

The illuminator 130 is positioned just outside the edge of the cold mirror 120 and is used to illuminate the iris of the subject being identified. The preferred illuminator  
5 130 emits light having wavelengths of about 680 to about 900 nanometers. Preferably, the illuminator 130 is a miniature quartz halogen or krypton gas bulb operating at approximately 1 watt.

The imager acquires images of an iris with sufficient clarity, focus, and size for use with conventional image processing and comparison routines, preferably in less than  
10 about 3 seconds. A preferred image processing and comparison routine is described in U.S. Patent No. 5,291,560, "Biometric Personal Identification System Based on Iris Analysis", issued to Daugman, and commonly assigned with the present invention to IriScan Inc., and incorporated herein by reference. However, any processing and comparison technique can be used with the image that is acquired at the imager, such as the image pixel correlation  
15 technique described in U.S. Patent No. 5,572,596, "Automated, Non-Invasive Iris Recognition System and Method", issued to Wildes et al. and the techniques described in U.S. Patent No. 4,641,349, "Iris Recognition System", issued to Flom et al., both of which are incorporated herein by reference.

Fig. 2A shows the apparatus of Fig. 1 in greater detail. The lens 110 gives  
20 a high resolution image of the eye 150 of the user, who is positioned in front of the lens 110, so that extreme proximity between the eye 150 and the imager 100 is not required (i.e., no contact is needed between the subject and the imager 100).

The handheld iris imager comprises a solid-state image capture device and an optical system which forms an image 109 of the iris on the image capture device at the  
25 image plane of the video camera 105 and at the same time produces a virtual image 115 of the iris which the user can use to position and focus the iris image. As a result, the user can, using the same eye being imaged, see a reflected image of the iris which can be used to position the handheld imager 100 so that a good iris image (i.e., an image that can be processed and compared to those stored in a database) can be obtained.

30 Fig. 2A also shows an optional dioptric correction lens 125 positioned between the eye 150 and the cold mirror 120. The dioptric correction lens 125 is an

adjustable optical element which corrects for the close-range focusing ability of the individual eye, which varies from subject to subject. When the lens 125 is properly adjusted, the magnified, reflected virtual image 115 of the subject's eye appears in sharp focus to the subject at the same eye-to-mirror distance at which the subject's eye is sharply  
5 focused on the front surface of the camera. This simplifies use of the imager, because the subject simply positions the image so that the virtual image 115 of the iris appears sharply focused.

A preferred embodiment of the dioptric correction mechanism has no correction lens 125 and instead has a mechanical means (not shown) for adjusting the  
10 position of the cold mirror 120 relative to the camera lens 110. This allows the user to vary the object distance of the cold mirror 120, thus changing the eye-to-lens distance at which the virtual image 115 of the iris is sharply focused.

The ability to set the dioptric correction mechanism to accommodate a particular user has a great utility if the imager is used by only one person most of the time.  
15 Once the correction is set, the user can easily position the device to obtain a sharply focused reflected image. This automatically produces a sharply focused image from the camera and substantially immediate acceptance of the image by the focus assessment processor described below. Image capture time is thereby reduced and overall convenience and utility is enhanced.

20 An eye 150 is positioned in front of the imager 100 (e.g., about 3.5 inches in front), as shown in Fig. 2A, and the illuminator 130 is turned on. This, in turn, illuminates the eye 150 and the iris therein. Preferably, the light having wavelengths of about 400 to about 700 nanometers is reflected by the cold mirror 120, thereby forming a magnified virtual image 115 behind the mirror 120 which the user can see through the eye  
25 being imaged. The radius of curvature of the mirror is selected so that the magnified image 115 of the eye substantially fills the user's entire field of view. Hence, when the imager 100 is positioned so that the entire eye 150 is visible, it is virtually assured that the eye 150 will be substantially centered in the object plane 140 of the camera 105. Under these conditions, the light having wavelengths of about 700 to about 900 nanometers is passed  
30 by the mirror 120 and forms an approximately centered image 109 of the eye 150 at the

image plane 107 of the camera 105. The image is then captured and processed, as described below.

Although a cold mirror (one which reflects shorter wavelengths and passes longer wavelengths) is described herein, it is understood that a hot mirror (one which  
5 reflects longer wavelengths and passes shorter wavelengths) could also be used in accordance with the present invention. Such a configuration is shown in an imager 101 in Fig. 2B. The eye 150 is illuminated by an illuminator 131 emitting light having wavelengths in the range of about 680 to 900 nanometers. This light is reflected by the eye 150 and the light having wavelengths in the range of about 700 to 900 nanometers is  
10 reflected by the hot mirror 121 to be focused by the lens 111 onto the front surface of the camera 106. Light reflected from the eye 150 having shorter (visible) wavelengths in the range of about 400 to 700 nanometers passes through the hot mirror 121 and strikes a concave broadband mirror 122 which reflects light having wavelength from about 400 to 900 nanometers. This light forms a virtual image 115 of the eye 150 behind the concave  
15 mirror 122 that the user can see and use to align and focus the device, as described below.

The imager 100 of Figs. 1 and 2A, as well as the imager of Fig. 2B, is used in a system to identify the iris image that has been captured. As shown in Fig. 3, the eye is illuminated at step 160, and an acceptable or suitable image of the iris is obtained at step 165. The image is processed to extract an iris template or code at step 170, the template  
20 or code is encrypted (optional) and transmitted to the cellular provider (such as a central station; e.g., a Mobile Telephone Switching Office) at step 175, and the template or code is decrypted (if necessary) and compared to pre-existing templates or codes of authorized subscribers stored in a memory or database for identification and authorization of the user at step 180. If the user is authorized, the cellular provider enables the call placement at step  
25 185. The cellular provider can either enable the call at the central station or send a signal to the telephone processor directing it to unlock the telephone.

Fig. 4 is a schematic diagram of an exemplary iris image recognition system in accordance with the present invention. The imager 100 is coupled to a microprocessor 210 that performs the processing and encryption. The microprocessor 210 resides in a  
30 cellular telephone 200.

The microprocessor 210 is coupled to the imager 100 via conventional cables and/or printed circuit boards (PCBs) that are incorporated into the telephone 200. Other conventional means for coupling the imager 100 and the microprocessor 210 can be employed. The microprocessor 210 controls the imager 100 and runs software held in read  
5 only memory (ROM) 205. The processor 210 is connected via a bus 207 to the ROM 205, a random access memory (RAM) 232, another memory such as an erasable programmable ROM (EPROM) 230, and an input/output (I/O) controller 225. The RAM 232 is large enough to hold at least one captured image of an iris. The I/O controller 225 is connected to the appropriate circuitry and drivers (not shown) for issuing commands to control the  
10 imager 100.

The imager 100 preferably uses a digital camera and transmits digital images directly to the processing unit 210. "On/off" data is transmitted from the imager 100 to the processor 210 to initiate the image acquisition function. A digital image could be provided if a digital camera is used.

15 The image processing consists of a number of image processing steps (such as those described in U.S. Patent No. 5,291,560 and U.S. Patent No. 5,572,596, which are herein incorporated by reference) which lead to extraction of a unique and highly specific digital biometric template that can be used to identify the individual based on intensity patterns within the iris. The biometric template is transmitted to the cellular provider where  
20 it is compared against other templates stored in a memory or database. The database stores selected data representing images of the iris of a plurality of subjects. A match of the biometric template with a template stored in the database identifies the subject whose iris is being imaged.

Although an image of the eye is reflected back to the subject in mirror 120,  
25 this may not provide the desired feedback to the user to enable the user to properly position the imager so that a suitable iris image is obtained. For example, a user may be a novice in using and positioning the imager 100 with respect to the eye 150, or the user may be attempting to image the eye of another subject with the imager. Thus, preferably, the imager 100 comprises a passive feedback mechanism to guide the user in positioning the  
30 eye 150 to an optimum location to allow acquisition of a suitable image.

The passive feedback mechanism is an indicator or combination of indicators that provides, on a near real-time basis, an indication to the user that an adequate iris image has or has not been obtained. Fig. 5 is a schematic diagram of an exemplary iris image recognition system that includes position indicators in accordance with the present invention. Preferably, the indicator is visible and/or audible, such as, for example, an indicator lamp 305 (e.g., a light emitting diode (LED)) that lights when an acceptable image has been captured (i.e., "image acquired"), and a aural indicator via a speaker 310, such as a beep or other tone, that sounds periodically until an acceptable image has been captured (i.e., "imaging in progress").

Additional indicators 306, 307 can be also be used, either alone or in combination, for such indications as "subject identified - accept" and "subject not identified - reject". These indications would be activated pursuant to the results of the processing and comparison performed at the database server at the cellular provider, as described above with respect to Fig. 3. Alternatively, other display devices, such as liquid crystal displays used for other purposes within the telephone, could be used as indicators.

The imager 100 also preferably has an on/off switch (not shown), such as a pushbutton, for powering up the imager and initiating the image acquisition process. Power for the imager 100 is preferably supplied by a battery. The imager 100 receives and acts on instructions from the processor 210 to perform functions such as lighting or turning off the indicator lamp(s) 305, providing the audible signals via the speaker 310, and lighting the 'accept' and 'reject' indicators.

Fig. 6 is a more detailed flow chart of a method of operation in accordance with the present invention. The eye is illuminated at step 350 and an image of the iris is obtained at step 355. At step 360, it is determined if the image is suitable for use with the image processing and comparison routines. If the image is suitable, the image is passed to the processor for further processing, at step 370, and transmission to the cellular provider. A comparison of the template to the templates stored in a database at the cellular provider is performed at step 373. If the comparison provides a positive match, then authorization is granted at step 376 for the user to use the phone. If the comparison does not provide a positive match, then authorization is not granted for the user to use the phone.

If the image is not suitable at step 360, then at step 380, the indicator(s) is activated (e.g., a beep sound is issued), and processing continues at step 355 (i.e., another image is obtained).

Because the eye's own focusing system automatically adjusts to bring the  
5 virtual image 115 into sharp focus to the user, it cannot be relied upon to always accurately focus the eye image on the camera 105. For this purpose, a focus assessment system is used in one embodiment, as shown in Fig. 7. Digital video image information from the imaging device 100 is stored in a frame buffer memory 410, such as a RAM similar to  
10 RAM 232 described above with respect to Fig. 4, and capable of storing one complete frame of digitized video information. A focus assessment processor 420 accesses the digitized image information and applies certain measurement algorithms which are disclosed in a co-pending application entitled "Video-Rate Focus Assessment", Serial No. 60/109,960 (Attorney Docket No. ICAN-0067), and incorporated herein by reference. The output of the focus assessment is used to control an indicator, such as the audible indicator 310. As  
15 long as the focus assessment processor 420 determines that the captured image is not acceptable for further processing and comparison, the audible indicator 310 is directed to emit periodic sounds to alert the user. Images are repeatedly acquired and assessed until an acceptable one is received. After an acceptable iris image has been received, the audible indicator 310 is turned off and the final image is retained for further processing and  
20 comparison, for example, by the microprocessor 210, as described above.

Any known technique for image focusing can be used with the imager of the present invention, such as those described in U.S. Patent 4,876,608, entitled "Focus and Signal to Noise Measurement Routines in Input Scanners", issued to Eaton, U.S. Patent  
25 5,151,583, entitled "Focus Adjustment Device Having Restricting Means for Restricting a Selecting Action According to the Degree of Nearness of a Distance Measurement", issued to Tokunaga et al., and U.S. Patent 5,404,163, entitled "In-Focus Detection Method and Method and Apparatus Using the Same for Non Contact Displacement Measurement", issued to Kubo. The preferred system and method for focus assessment is described below.

A focus score is computed for each video frame (i.e., each captured image).  
30 If the focus score exceeds a predetermined value, then it is determined that the image is focused enough for further processing and comparison. If the focus score does not exceed

the predetermined value, then it is determined that the image is not focused enough for further processing, and an indicator (such as indicator 310, described with respect to Fig. 5) is activated and a further image is captured. Alternatively, a sequence of image frames can be obtained that cycle through a range of focus distances strobed at the video frame-  
5 rate, and the focus score computed for each frame can enable the selection of the best focused frame within the sequence of frames. For example, by obtaining image frames at each of several different lens settings and then fitting a spline curve to their respective focus scores one can predict the lens position that would deliver substantially the sharpest focus, by setting the derivative of the parameterized spline curve to zero and then solving the  
10 equation for position.

Specific implementation features of the preferred focus assessment system and method which enable its real-time operation, include (1) the computation of quantities in the 2D Fourier domain, without needing to compute an actual 2D Fourier Transform of an image (this avoids the need for approximately 2.25 million floating-point operations  
15 required for an FFT (Fast Fourier Transform) on a 500 x 500 pixel image, as the computational complexity of an FFT on  $n \times n$  data is  $O(n^2 \log_2 n)$ ); (2) only 6,400 integer multiplications (squarings) are performed, which in turn can be eliminated altogether by using small look-up tables; (3) no floating-point operations are required; (4) computation of focus scores is based upon simple algebraic combinations of pixel values within local  
20 closed neighborhoods, repeated across regions of the image; and (5) these operations not only allow the algorithm to execute in real-time, but it also enables a straightforward implementation in simple, low-cost, hardware devices that could be embedded within a digital camera or frame grabber.

Preferably, the focus assessment processor 420 is fast enough to determine  
25 a focus score for each frame in a video image stream in less than the time it takes to acquire a new frame (e.g., approximately 25 ms). The frame-by-frame focus scores can be used to control a moving lens element for rapid and accurate focus control, or alternatively, to select which of several frames in a video stream is the one in best focus. The rapid selection of well-focused video frames for further processing, such as image analysis and  
30 pattern recognition, is important in real-time computer vision because it prevents wasting processing time on poorly-focused images.

The preferred focus assessment processor measures the focus quality of video images at standard rates of 25 (PAL) or 30 (NTSC) frames per second.

It is contemplated that the focus assessment processor 420 can be implemented in a general purpose personal computer (PC) or by a dedicated, low cost processor which is small enough to be incorporated into the camera electronics.

The processing of a video frame results in the return of an integer value (on a scale between 0 and 100) reflecting the quality of focus; the larger the value of the integer, the better the focus. A value of 0 indicates a completely defocused image whereas the value of 100 indicates maximum focus quality. A predetermined threshold is used to determine whether an image is sufficiently focused or whether another image needs to be retrieved. For example, values greater than about 40 can indicate sufficient quality of focus to warrant further image processing, while values less than about 40 cause a new image frame to be grabbed, and optional feedback provided to the focusing mechanism, if one exists, or to the subject controlling the camera position (via the indicator 310, for example).

Optical defocus is a phenomenon of the 2D Fourier domain. An image represented as a 2D function of the real plane,  $I(x,y)$ , has a 2D Fourier Transform  $F(\mu, \nu)$  defined as shown in equation 1.

$$F(\mu, \nu) = \frac{1}{(2\pi)^2} \iint_{XY} I(x, y) e^{i(\mu x + \nu y)} dx dy \quad (1)$$

In the image domain, defocus is preferably represented as convolution by the 2D point-spread function of the defocused optics. This in turn may be modeled as a Gaussian whose space constant is proportional to the degree of defocus. Thus, for perfectly focused optics, the optical point-spread function shrinks almost to a delta function, and convolution with a delta function causes no change to the image. Progressively defocused optics equates to convolving with a wider and wider point-spread function, which averages together whole neighborhoods of pixels by such a weighting function, thereby producing an increasingly blurred image.

If the convolving optical point-spread function causing defocus is modeled as a Gaussian whose width represents the degree of defocus, then defocus is equivalent to multiplying the 2D Fourier Transform of a perfectly focused image with the 2D Fourier



Transform of the "defocusing" (convolving) Gaussian. This latter quantity is itself just another 2D Gaussian but in the Fourier domain, and its space constant ( $\sigma$ ) there is the reciprocal of that of the image-domain convolving Gaussian that represented the optical point-spread function. The preferred focus assessment processor uses (1) the duality of convolution and multiplication in the two domains; (2) the fact that a Gaussian has a Fourier Transform which is itself a Gaussian, but with the reciprocal width because of (3) the Similarity Theorem. Thus, the 2D Fourier Transform  $D_o(\mu, \nu)$  of an image defocused to degree  $\sigma$  is related to  $F(\mu, \nu)$ , the 2D Fourier Transform of the corresponding in-focus image, as given by equation 2.

$$10 \quad D_o(\mu, \nu) = e^{-\left(\frac{\mu^2 + \nu^2}{\sigma^2}\right)} F(\mu, \nu) \quad (2)$$

From the above equation, the effect of defocus is to attenuate primarily the highest frequencies in the image, and that lower frequency components are virtually unaffected by defocus since the exponential term approaches unity as the frequencies  $(\mu, \nu)$  become small. For simplicity, the present description has assumed isotropic optics and isotropic blur, and the optical point-spread function has been described as a Gaussian. However, the analysis can readily be generalized to non-Gaussian and to anisotropic optical point-spread functions.

Thus, an effective way to estimate the quality of focus of an image is to measure its total amount of energy in the 2D Fourier domain at high spatial frequencies, since these are the most attenuated by defocus. One may also perform a kind of "contrast normalization" to make such a spectrally-based focus measure independent of image content, by comparing the ratio of energy in the highest frequency bands to that in slightly lower frequency bands. Such spectrally-based energy measurements are facilitated by exploiting Lord Rayleigh's theorem for conserved total power in the two domains, shown in equation 3.

$$25 \quad \int_{-\infty}^{+\infty} \int_{-\infty}^{+\infty} |I(x, y)|^2 dx dy = \int_{-\infty}^{+\infty} \int_{-\infty}^{+\infty} |F(\mu, \nu)|^2 d\mu d\nu \quad (3)$$

Thus, high-pass filtering or band-pass filtering an image at a ring of high spatial frequency (using only convolution in the 2D image domain) and measuring the residual energy, is equivalent to making the corresponding energy measurement in the high frequency bands of the 2D Fourier domain. The appropriate measurements in the 2D Fourier domain to  
 5 assess focus can be performed without computing a time-consuming 2D Fourier Transform. Indeed, the measurements can be performed without even a single floating-point operation, and even without any multiplications if appropriate convolution kernels and look-up tables are used.

A real-time procedure for focus assessment based on these theoretical  
 10 principles is used in the focus assessment processor 420. It executes much faster than the video frame-rate, and so real-time focus assessments can be made on a frame-by-frame basis. These can be used either to control the position of a focusing lens element, or alternatively as a type of autofocus system in which frames are grabbed at a variety of focal depths in order to select only the best one for processing, or to prevent time being wasted  
 15 on processing image frames which are assessed to be in poor focus.

The 2D spectral measurements described above can be implemented by convolving an image with the following convolution kernel, in which pixel values within a predetermined region, such as, for example, an (8 x 8) neighborhood, are added together with the weights indicated in each of the cells:

20

-1	-1	-1	-1	-1	-1	-1	-1
-1	-1	-1	-1	-1	-1	-1	-1
-1	-1	+3	+3	+3	+3	-1	-1
-1	-1	+3	+3	+3	+3	-1	-1
-1	-1	+3	+3	+3	+3	-1	-1
-1	-1	+3	+3	+3	+3	-1	-1
-1	-1	-1	-1	-1	-1	-1	-1
-1	-1	-1	-1	-1	-1	-1	-1

25

It should be noted that no pixel-by-pixel multiplications are needed in order to impose these weights. Rather, the pixels in the central region are added together, such as the (4 x 4)

square, that sum is tripled, and then all pixel values in the outer two pairs of rows and columns are subtracted from the tripled sum. The result is squared and added to an accumulator, thus implementing the left-hand side of equation (3) above for this local region of the image. The complete (8 x 8) convolution kernel is then moved to a new position in  
 5 the image, along a sampling grid that selects every 4th row and every 4th column, and the operation is repeated. Thus, to assess the quality of focus within the central (320 x 320) region of an image, this set of 64 pixel summations followed by a squaring operation is repeated a total of  $(320/4)^2 = 6,400$  times.

In the 2D Fourier domain, the spectral consequences of this operation can  
 10 be appreciated by examining the 2D Fourier Transform of the convolution kernel above. The kernel is equivalent to the superposition of two centered square box functions, one of size (8 x 8) and amplitude -1, and the other of size (4 x 4) and amplitude +4 (for the central region in which they overlap, the two therefore sum to +3). The 2D Fourier Transform of each of these square functions is a 2D "sinc" function, whose size parameters  
 15 differ by a factor of two in each of the dimensions and whose amplitudes are equal but opposite, because the two component boxes have equal but opposite volumes. Thus, the overall kernel has a 2D Fourier Transform  $K(\mu, \nu)$  which is the difference of two differently-sized 2D sinc functions, as given by equation 4.

$$K(\mu, \nu) = \frac{\sin(\mu)\sin(\nu)}{\pi^2\mu\nu} - \frac{\sin(2\mu)\sin(2\nu)}{4\pi^2\mu\nu} \quad (4)$$

20 This is a high-pass (or ultimately a band-pass) filter, selecting only a high range of spatial frequencies in all orientations. Towards its center, corresponding to very low spatial frequencies, its value approaches zero (as can also be inferred from the fact that the sum of all pixel weights in the convolution kernel shown above is zero). Thus, low frequencies play little or no role in computing a focus score, and only relatively high  
 25 frequencies contribute significantly to the computation of a focus score. Equation (3) shows that summing the squares of all the local convolution sums across the image is equivalent to summing the total amount of high frequency energy in the 2D Fourier Transform of the image. The action of the convolution kernel is to impose the above power spectral weighting function so that primarily high frequency energy is measured.

Finally, the summated 2D spectral energy is passed through a compressive nonlinearity of the form  $f(x) = 100 x^2 / (x^2 + c^2)$  in order to generate a normalized focus score in the range of 0 to 100 for any image.

The focus assessment technique is applied immediately after each image  
5 frame is digitized and stored in the frame buffer memory 410 in order to assess whether the focus quality is sufficient to warrant any further processing. If the calculated focus quality value of the captured image is greater than or equal to a predetermined value, the image is passed to applicable programs for further processing, for example for extraction of a biometric template. The focus assessment technique can be used to compare the relative  
10 focus of an entire series of images in order to select the one most in-focus (i.e. having the highest focus assessment score), as well as to measure a single image.

The focus assessment technique can be used to provide a feedback indication to a system user who controls the position of the imager relative to the object being imaged. This can be accomplished by activating an indicator which would continue, while successive  
15 images are captured and their focus assessed, until the focus assessment score exceeds a predetermined value. At this point, the indicator is deactivated and the last image captured is transferred to the image processor 210 where it is processed to extract the biometric template.

The application of the focus assessment technique in combination with the  
20 feedback indicator helps resolve the man-machine interface problems associated with the use of digital imaging devices on the eye. Individuals using the system are provided positive, objective indicators and feedback as to the quality of image focus. The focus assessment processor can also be used in any situation where it is required to determine the quality of focus of video images at industry standard frame rates (NTSC and PAL).

25 Thus, the image is obtained at the imager and transmitted to an analog to digital converter 405. The digitized video information is then stored in a frame buffer memory 410. The focus assessment processor 420 isolates the central 320 x 320 region of the image. 8 x 8 pixel blocks (each pixel is in only one block) are then processed by first summing pixels in the central 4 x 4 region, tripling that sum, and then subtracting from this  
30 value all the pixel values in the outer two pairs of rows and columns. This result is then squared. This process is performed on each 8 x 8 block, and the results are summed. After

the entire image has been processed, the summed result is compressed nonlinearly to generate a focus score between 0 and 100. This score is then compared to a predetermined number for determining if the indicator 310 should be activated.

The focus assessment is preferably performed by the microprocessor 210,  
5 or it can be a separate processor element within the telephone.

It is contemplated that in addition to the focus assessment processor, an auto-focus lens system could be used in the present invention. The results of the focus assessment control the lens system, thereby automatically adjusting focus to produce an optimal image. This would place less of a premium on the accuracy with which the user  
10 positions the eye, and would be helpful if the user could not see or hear the indicators described above.

The iris imager of the present invention can be used as a security module for electronic devices such as a telephone. Fig. 8 is a schematic diagram of an exemplary iris imager incorporated into a telephone in accordance with the present invention. The imager  
15 700 comprises the camera 105, lens 110, mirror 120, and illuminator 130, as described above with respect to Fig. 1. The imager 700 also comprises visible indicators 555, 556, 557, which are similar to indicators 305, 306, 307, respectively, described above with respect to Fig. 5. An audible indicator 560, similar to indicator 310, is also disposed within the imager 700. The imager 700 further comprises electronics and circuitry 500 for  
20 processing and comparing the obtained image. The electronics and circuitry 500 comprises a microprocessor 510 (similar to microprocessor 210) that controls the imager 700 along with an I/O controller 525 and runs software held in a ROM 505. The processor 510 is connected to the ROM 505, a RAM 532 that is capable of storing at least one captured image or an iris, another memory 530, such as an EPROM, for storing a plurality of  
25 biometric templates or iris images that are to be compared with the captured iris image. The electronics and circuitry 500 is also connected to the camera 105, the illuminator 130, and the indicators 555, 556, 557, 560 for controlling these elements of the imager 700. The processor can also comprise a focus assessment processor, similar to the focus assessment processor 420.

30 It should be noted that in the embodiment of Fig. 8, the database memory 530 of templates is stored within the imager 700 and not at a central station (as described,

for example, with respect to Fig. 4), as is the processor 510 used in the comparison. In the embodiment of Fig. 8, the comparison of the captured image template with the stored templates takes place locally within the telephone, and the biometric template is not sent to the central station for comparison or authentication. Instead, preferably, a code is inserted  
5 into the call set-up protocol and transmitted to the central station server, as described below.

The imager 700 is coupled to telephone electronics 570 for transmitting encrypted or unencrypted data to another telephone or system via an antenna. The telephone electronics 570 is essentially a telephone and is preferably a conventional cell  
10 phone having telephone electronics and is connected to a transmission antenna. Preferably, a conventional voltage regulator (not shown) provides the appropriate operating voltage to the imager 700 from the power supply (e.g., a battery) of the phone.

Preferably, the imager 700 of the present invention is incorporated into a handset of a telephone 575, as shown in Fig. 9A. The present invention can be  
15 incorporated into a conventional digital cell phone, as shown in Fig. 9A, such as those manufactured by Qualcomm or Nokia, or a conventional wired phone. U.S. Patent No. 5,448,622, "Cellular Telephone With Plural Telephone Numbers", issued to Huttunen, and U.S. Patent No. 5,790,957, "Speech Recall In Cellular Telephone", issued to Heidari, describe cellular telephones and telephone electronics and circuitry, and both of which are  
20 incorporated herein by reference.

Figs. 9B, 9C, and 9D show rear, side, and front elevational views of another exemplary device 800, also referred to as an IRISPHONE™, in which the imager of the present invention can be incorporated. A keypad 810 is used to enter phone numbers, etc., which are displayed on a display 815, such as an LCD, and a power supply 820 is  
25 preferably a re-chargeable battery. A transmission antenna 830 is also provided. An illuminator 840, similar to the illuminator 130, and a mirror 850, similar to the mirror 120 are provided on the front of the device 800. Also provided on the front of the device 800 is a microphone 860 and a speaker 865, for use in communications and as an indicator, similar to the indicator 310, described above. A switch or button 805 is used as an  
30 activator to begin iris image capture. The imager and phone circuitry 870 is encased within the device 800.

Fig. 10 is a flow diagram of an exemplary method of operation of a telecommunications iris imager in accordance with the present invention. A user desiring to make a telephone call first unlocks the telephone by having his iris identified by the imager residing within the phone. The eye, and thus the iris, are illuminated at step 605.

5 An image is obtained of the iris at step 610. At step 615, it is determined if the image is suitable for further processing and comparison, as described above. If the image is not suitable, the appropriate indicators are activated at step 620, and processing returns to step 610 with the capture of another iris image.

If the captured image is suitable for further processing, the image is  
10 processed at step 630 (an indicator can be activated to alert the user that a suitable image has been captured) to extract an iris template. The extracted template is compared to the stored images residing in a database, for example, in a memory 530, at step 635. If the iris template is invalid (i.e., if there is no match between the captured image and the stored images), at step 640, the phone remains off (locked), and the imaging routine exits.  
15 Optionally, indicators can also be activated. In this manner, the telephone remains locked, and cannot be used because it is determined that the user is unauthorized.

If the iris template is valid at step 635 (i.e., there is a match between the captured image and the stored images, and thus the identity of the user has been confirmed by the imager), the phone is turned on (unlocked), an indicator can be activated, and a user  
20 code is transmitted to the service provider (e.g., the central station server 900, as shown in Fig. 11) at step 650. The user code, also referred to as an IRISCODE™, comprising a 512 byte code for example, is generated and is inserted into the call set-up protocol and transmitted to the server 900.

At step 660, the server authenticates the IRISCODE™ against stored or pre-  
25 enrolled codes that are stored in a database 910 at the server site. If the code is invalid, then the user is not authorized to place a call, an indicator is activated at the phone, and the routine exits at step 670. If the code is valid, then the user can use the phone to place a call at step 680. The phone can be returned to its locked, secure state either upon being powered down or upon completion of the phone call.

30 Thus, in accordance with the present invention, the server can bill against the user's identity (responsive to the IRISCODE™) and not the phone number. Thus,

different users can use the same phone, and be separately billed, according to the identities that are stored at the server. This provides an additional level of security and user validation.

It should be noted that any call set-up protocol can be used with the present invention, including GSM, TAC, and AMPS. For example, in the Group Speciale Mobile (GSM) cellphone architecture, an "Intel Architecture" microprocessor and "Intel SmartVoltage" flash memory are preferred components. The basis of this technology is a microprocessor, such as the Intel 386 microprocessor. The preferred memory is a non-volatile, re-writeable, low voltage flash memory that enables computer-like functions. In the case of a Nokia cellphone, for example, a 4-Mbit flash memory storage device stores the GSM protocol. Intel's 16-Mbit flash devices can store such things as phone numbers, fax numbers, calendar information, as well as a Graphical User's Interface (GUI) operating system. Similarly, each IRISCODE™ (e.g., 512 bytes) of the users can be stored in these flash memory devices. Preferably, about 40 pairs of IRISCODEs (one IRISCODE™ for the left eye and one IRISCODE™ for the right eye for each user) can be stored in the 4-Mbit devices and about 160 pairs of IRISCODEs can be stored in the 16-Mbit devices.

The operating system performs such functions as: (1) retrieve the live IRISCODE™ from the IRISPHONE™ image, (2) compare the "live" IRISCODE™ against the IRISCODE™ database stored in the memory (e.g., flash memory), and (3) transfer, upon positive identification, the authentication into the GSM protocol for transport to the wireless GSM server. This is done in a manner similar to the manner in which the Electronic Serial Number (ESN) is authenticated.

The Wireless Application Protocol (WAP), along with the Wireless Application Environment (WAE), have been developed to extend Internet content and advanced services to the cellphone industry. A wireless IRISPHONE™ captures an IRISCODE™ using the WAE user agent that sends the code to the cellphone memory for local authentication. An encoded request for authentication and identity is then sent to the origin server. An encoded positive identification or negative identification is returned, and either allows the user to make calls via identity-based billing or disallows all calls. For example, the call reject function would be used to reject the identity of an individual if the



live IRISCODE™ did not match any stored value. The WAP Mark-up Language (WML) allows for user defined fields such as IRISCODEs.

The Electronic Business Card Format of WAP/WAE is compatible with a 512 byte IRISCODE™. The IRISCODE™ can be stored on a card instead of in flash  
5 memory.

Although illustrated and described herein with reference to certain specific embodiments, it will be understood by those skilled in the art that the invention is not limited to the embodiments specifically disclosed herein. Those skilled in the art also will appreciate that many other variations of the specific embodiments described herein are  
10 intended to be within the scope of the invention as defined by the following claims.

**What is claimed is:**

1. A telecommunications device having telephone electronics for transmitting and receiving data, comprising:

a telephone security module comprising:

5 iris acquisition means having a front surface for obtaining an image of an iris of an eye;

a lens having an image plane disposed in front of said front surface of said iris acquisition means;

a mirror disposed on a side of said lens opposite said iris acquisition means;

10 an illuminator disposed along a side of said mirror;

a first memory for storing at least one template of at least one image of an iris of at least one person's eye;

a second memory for storing an iris image obtained by said iris acquisition means;

15 a processor for extracting a template from said stored iris image; and

a comparator for comparing said template from stored iris image with said at least one template to identify the person;

an input device for receiving user input;

a display for displaying said user input;

20 a power supply;

an antenna;

a microphone;

a speaker; and

an activator to begin iris image acquisition.

25

2. The telecommunications device according to claim 1, wherein said input device is a keypad.

3. The telecommunications device according to claim 1, wherein said power

supply is a re-chargeable battery.

4. The telecommunications device according to claim 1, wherein said activator is one of switch and a pushbutton.

5. The telecommunications device according to claim 1, wherein said iris acquisition means comprises a camera, and said mirror is a cold mirror.

6. The telecommunications device according to claim 5, wherein said camera is sensitive to light having a wavelength in a range between about 400 nm and about 1100 nm.

7. The telecommunications device according to claim 5, wherein said mirror reflects light having a wavelength in a range between about 400 nm and about 700 nm and passes light having a wavelength greater than about 700 nm.

8. The telecommunications device according to claim 1, wherein said illuminator emits light having a wavelength in a range between about 680 nm and about 900 nm towards the iris of the eye being imaged, the eye being out of contact with the iris imaging apparatus.

9. The telecommunications device according to claim 1, further comprising at least one of a visible indicator and an audible indicator to indicate when the image of the iris has been obtained.

10. The telecommunications device according to claim 9, further comprising a focus assessment processor coupled to said at least one of a visible indicator and an audible indicator.

11. The telecommunications device according to claim 1, wherein said processor unlocks the telecommunications device responsive to the results of said comparison.

12. A telecommunications device having telephone electronics for transmitting and receiving data, comprising:

a telephone security module comprising:

- 5 iris acquisition means having a front surface for obtaining an image  
of an iris of an eye;  
a lens having an image plane disposed in front of said front surface  
of said iris acquisition means;  
a mirror disposed on a side of said lens opposite said iris acquisition  
means;  
10 an illuminator disposed along a side of said mirror;  
a memory for storing an iris image obtained by said iris acquisition  
means;  
a processor for extracting a template from said stored iris image; and  
a communications interface for transmitting said template to a central  
15 station;  
an input device for receiving user input;  
a display for displaying said user input;  
a power supply;  
an antenna;  
20 a microphone;  
a speaker; and  
an activator to begin iris image acquisition,  
wherein said processor unlocks the telecommunications device responsive to  
a signal received from said central station.

25 13. A method of unlocking a telecommunications device responsive to the identification of a person, comprising the steps of:

- (a) storing image information of the iris of at least one person's eye;
- (b) illuminating an eye of an unidentified person having an iris;
- (c) obtaining an image of said iris of said unidentified person;

(d) determining if said image is an image of sufficient quality for a step (f) of extracting;

(e) repeating steps (b) through (d) until said image of sufficient quality is obtained;

5 (f) extracting an iris template if said image is of sufficient quality;

(g) comparing said iris template of said obtained image with said stored image information to identify said unidentified person; and

(h) unlocking the telecommunications device responsive to a result of said step of comparing.

10 14. The method according to claim 13, further comprising the step of activating an indicator if said image is of insufficient quality.

15. The method according to claim 14, wherein said indicator is an audible indicator.

16. The method according to claim 13, further comprising the step of activating  
15 an indicator responsive to said step of comparing.

17. The method according to claim 16, wherein said indicator is a visible indicator.

18. The method according to claim 13, wherein said step of determining if said image is an image of sufficient quality comprises the step of focus assessment processing  
20 said image.

19. The method according to claim 13, wherein said telecommunications device is unlocked if said step of comparing identifies said person.

20. The method according to claim 13, wherein said step of unlocking the

telephone comprises the steps of unlocking the telecommunications device if said iris template substantially matches said stored image information and generating a user code, wherein the telecommunications device remains locked if said iris template does not substantially match said stored image information.

- 5 21. The method according to claim 20, further comprising the step of activating an indicator if said iris template substantially matches said stored image information.
22. The method according to claim 20, further comprising the step of transmitting said user code to a service provider via a set-up protocol.
23. The method according to claim 22, wherein said set-up protocol is one of  
10 GSM, TAC, and AMPS.
24. The method according to claim 22, further comprising the steps of:  
authenticating said user code at said service provider;  
if said user code is authentic, authorizing a telephone call to be placed,  
otherwise, preventing a telephone call from being placed.
- 15 25. The method according to claim 24, wherein the step of authenticating comprises comparing said user code to a plurality of predetermined codes.
26. The method according to claim 25, wherein said predetermined codes are stored in a server database.
27. The method according to claim 24, further comprising the step of activating  
20 an indicator responsive to said step of authenticating.
28. The method according to claim 24, wherein if said user code is authentic, further comprising the steps of placing a telephone call and billing against an identity of said person.

29. A telephone security module comprising:  
iris acquisition means having a front surface for obtaining an image of an iris  
of an eye;  
a lens having a image plane disposed in front of said front surface of said iris  
5 acquisition means;  
a mirror disposed on a side of said lens opposite said iris acquisition means;  
an illuminator disposed along a side of said mirror;  
a memory for storing an iris image obtained by said iris acquisition means;  
a processor for extracting a template from said stored iris image; and  
10 a communications interface for transmitting said template to a central station.
30. The telephone security module according to claim 29, wherein said iris  
acquisition means comprises a camera, and said mirror is a cold mirror.
31. The telephone security module according to claim 30, wherein said camera  
is sensitive to light having a wavelength in a range between about 400 nm and about 1100  
15 nm.
32. The telephone security module according to claim 30, wherein said mirror  
reflects light having a wavelength in a range between about 400 nm and about 700 nm and  
passes light having a wavelength greater than about 700 nm.
33. The telephone security module according to claim 29, wherein said  
20 illuminator emits light having a wavelength in a range between about 680 nm and about 900  
nm towards the iris of the eye being imaged, the eye being out of contact with the iris  
imaging apparatus.
34. The telephone security module according to claim 29, further comprising at  
least one of a visible indicator and an audible indicator to indicate when the image of the  
25 iris has been obtained.

35. The telephone security module according to claim 34, further comprising a focus assessment processor coupled to said at least one of a visible indicator and an audible indicator.
36. The telephone security module according to claim 29, wherein said processor  
5 unlocks a telephone responsive a signal received from said central station.
37. A method of unlocking a telephone responsive to the identification of a person, comprising the steps of:
- (a) storing image information of the iris of at least one person's eye;
  - (b) illuminating an eye of an unidentified person having an iris;
  - 10 (c) obtaining an image of said iris of said unidentified person;
  - (d) determining if said image is an image of sufficient quality for a step (f) of comparing;
  - (e) repeating steps (b) through (d) until said image of sufficient quality is obtained;
  - 15 (f) comparing a template of said obtained image with said stored image information to identify said unidentified person; and
  - (g) unlocking the telephone responsive to a result of said step of comparing.
38. The method according to claim 37, further comprising the step of activating an indicator if said image is of insufficient quality.
- 20 39. The method according to claim 38, wherein said indicator is an audible indicator.
40. The method according to claim 37, further comprising the step of activating an indicator if said image is of sufficient quality.
41. The method according to claim 40, wherein said indicator is a visible  
25 indicator.



42. The method according to claim 37, further comprising the step of activating an indicator responsive to said step of comparing.
43. The method according to claim 42, wherein said indicator is a visible indicator.
- 5 44. The method according to claim 37, wherein said step of determining if said image is an image of sufficient quality comprises the step of focus assessment processing said image.
45. The method according to claim 37, wherein said telephone is unlocked if said step of comparing identifies said person.
- 10 46. A system of identification of a person for unlocking a telephone, comprising:  
the telephone security module of claim 29;  
a second memory for storing at least one template of at least one image of an iris of at least one person's eye; and  
a second processor for comparing said template of said stored iris image with  
15 said at least one stored template of said second memory to identify the person, and for unlocking the telephone responsive to the result of said comparison.
47. The system according to claim 46, wherein said second memory and said second processor are housed in a central station remote from the telephone security module.
48. The system according to claim 46, wherein said second processor unlocks  
20 the telephone when said template of said stored iris image substantially matches said at least one stored template of said second memory.
49. A telephone security module comprising:  
iris acquisition means having a front surface for obtaining an image of an iris  
of an eye;

a lens having a image plane disposed in front of said front surface of said iris acquisition means;

a mirror disposed on a side of said lens opposite said iris acquisition means;

an illuminator disposed along a side of said mirror;

5 a first memory for storing at least one template of at least one image of an iris of at least one person's eye;

a second memory for storing an iris image obtained by said iris acquisition means;

a processor for extracting a template from said stored iris image; and

10 a comparator for comparing said template from stored iris image with said at least one template to identify the person.

50. The telephone security module according to claim 49, wherein said iris acquisition means comprises a camera, and said mirror is a cold mirror.

51. The telephone security module according to claim 50, wherein said camera  
15 is sensitive to light having a wavelength in a range between about 400 nm and about 1100 nm.

52. The telephone security module according to claim 50, wherein said mirror reflects light having a wavelength in a range between about 400 nm and about 700 nm and passes light having a wavelength greater than about 700 nm.

20 53. The telephone security module according to claim 49, wherein said illuminator emits light having a wavelength in a range between about 680 nm and about 900 nm towards the iris of the eye being imaged, the eye being out of contact with the iris imaging apparatus.

54. The telephone security module according to claim 49, further comprising at  
25 least one of a visible indicator and an audible indicator to indicate when the image of the iris has been obtained.

55. The telephone security module according to claim 54, further comprising a focus assessment processor coupled to said at least one of a visible indicator and an audible indicator.

56. The telephone security module according to claim 49, wherein said processor  
5 unlocks a telephone responsive to the results of said comparison.

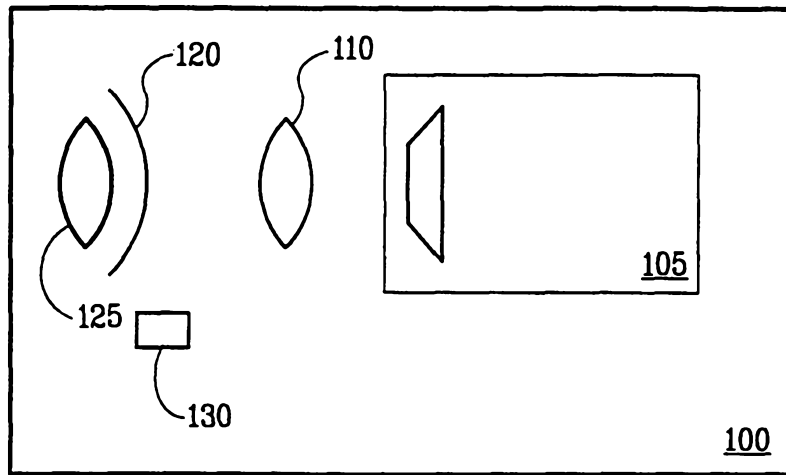

FIG. 1

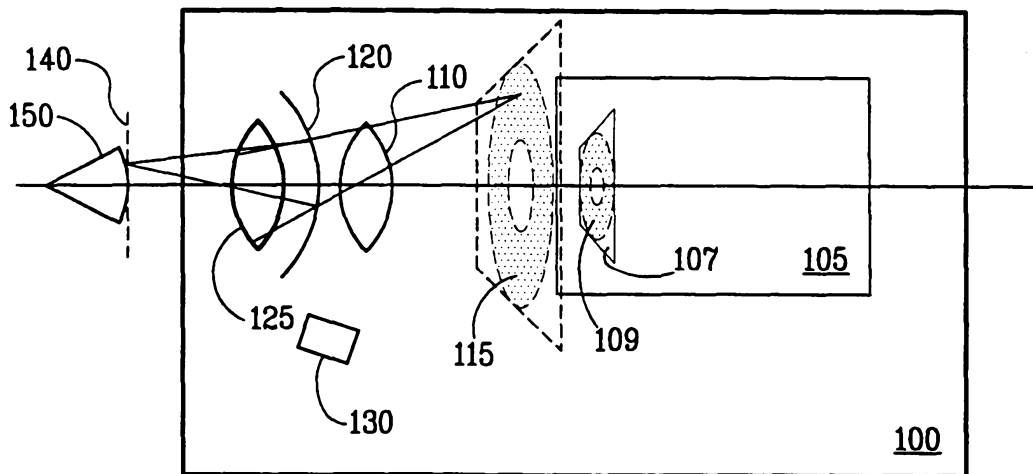

FIG. 2A

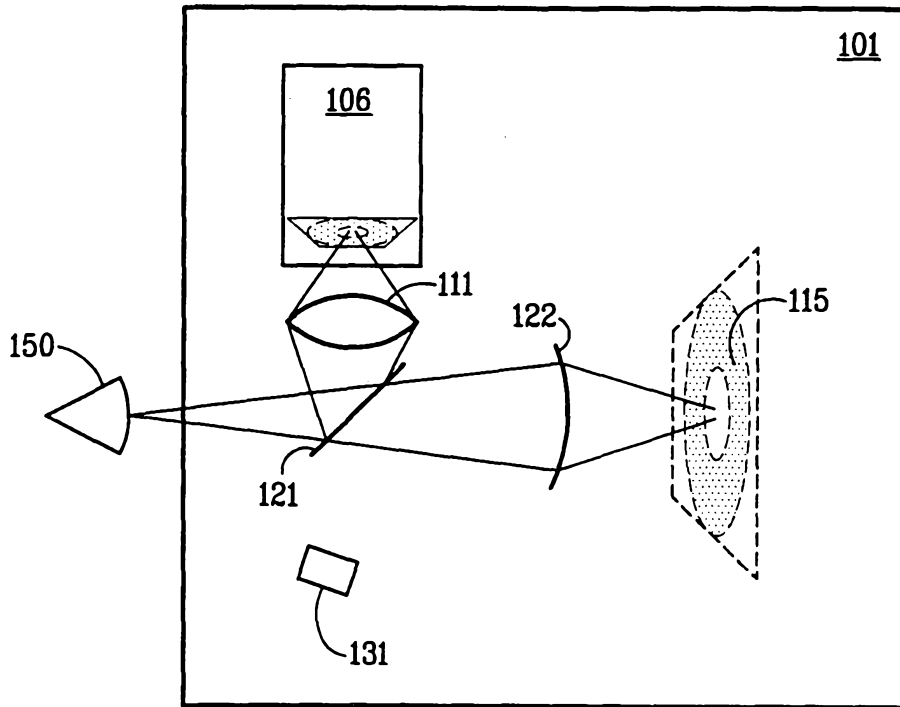

FIG. 2B

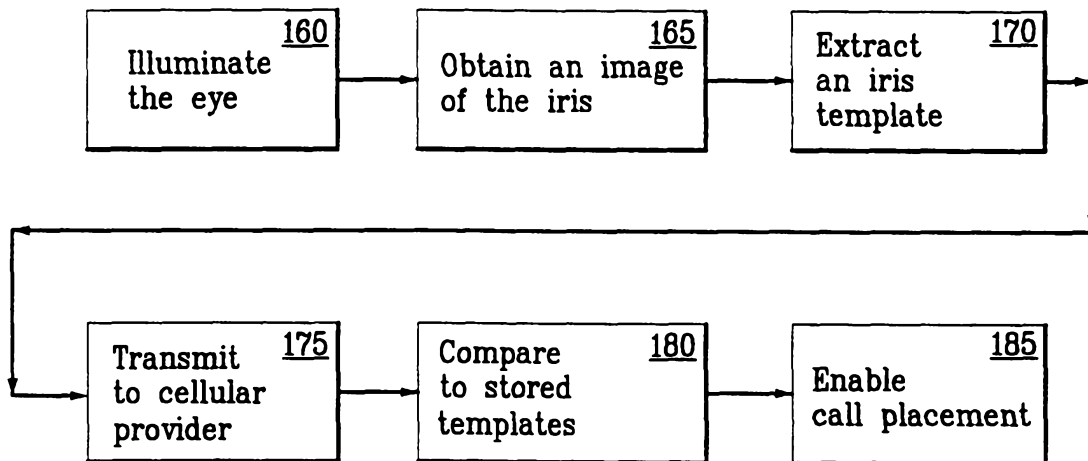
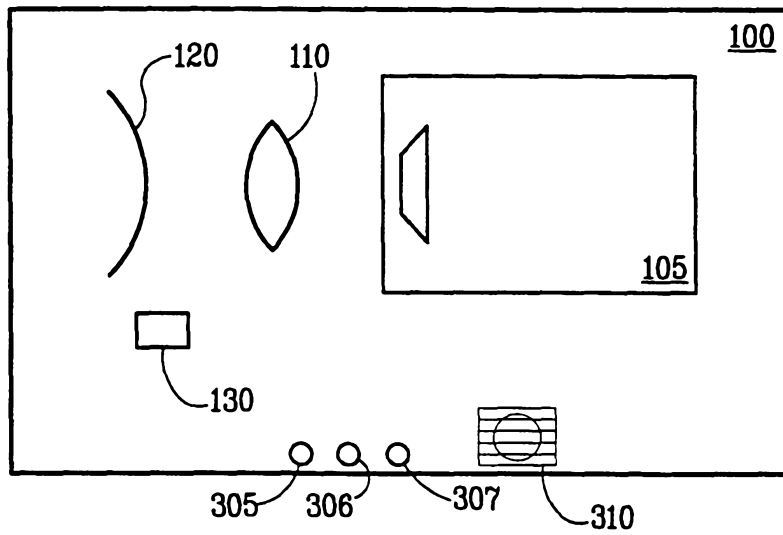
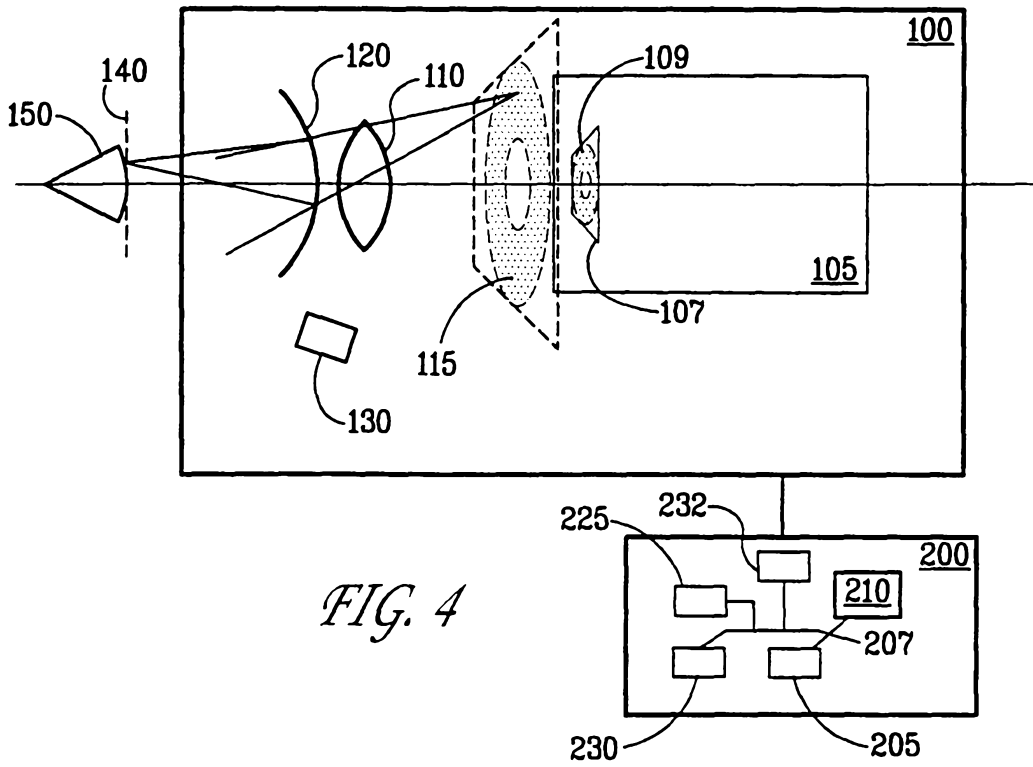

FIG. 3



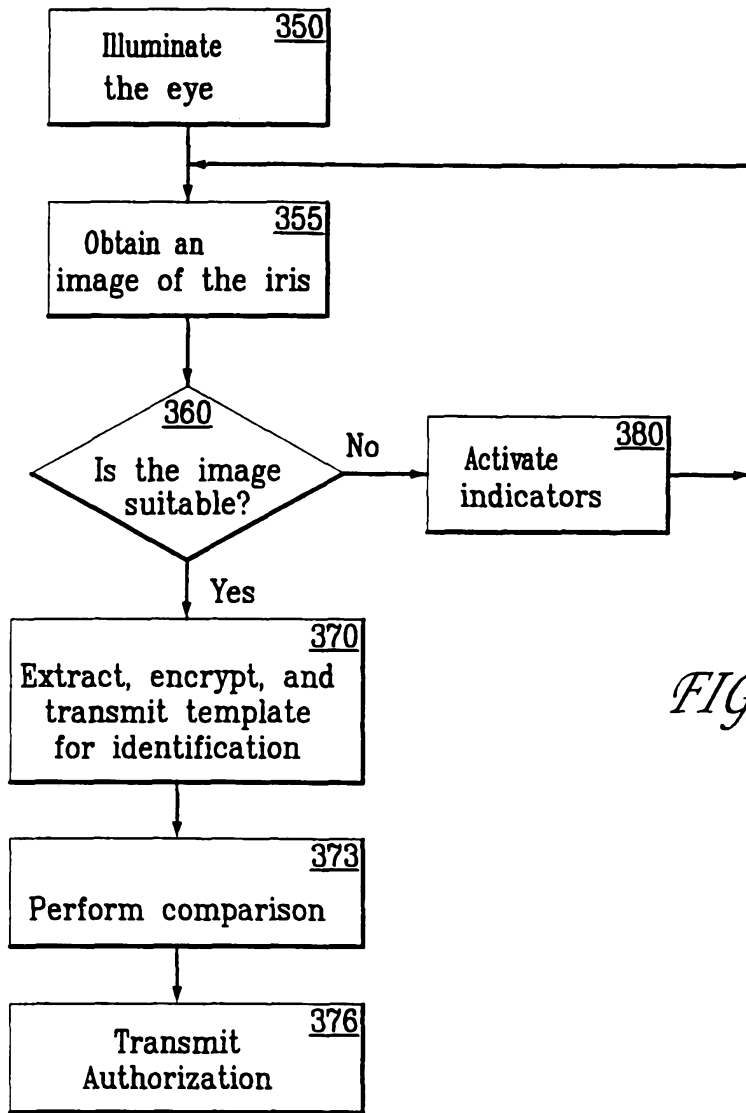

FIG. 6

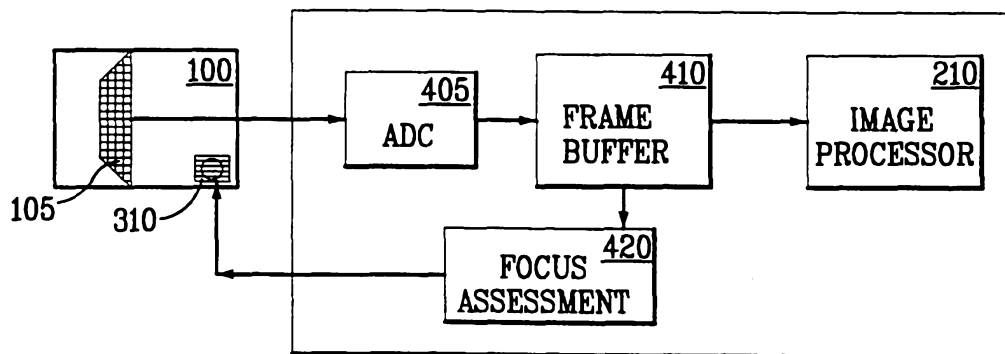

FIG. 7

FIG. 8

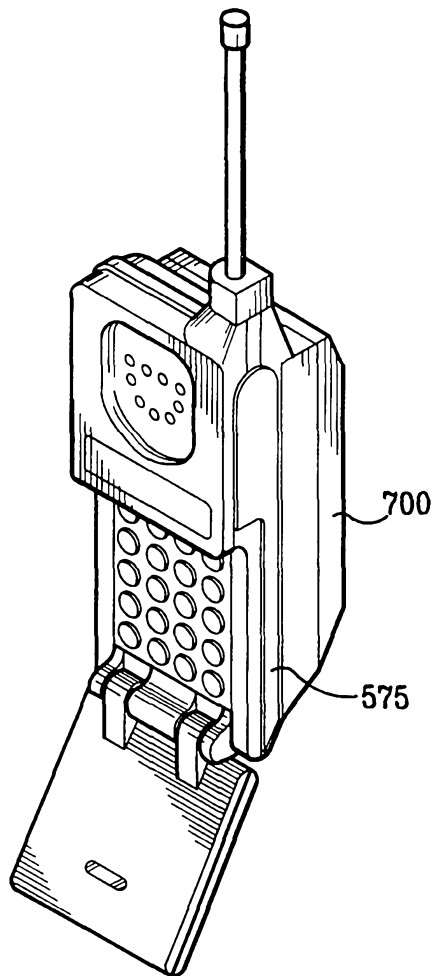
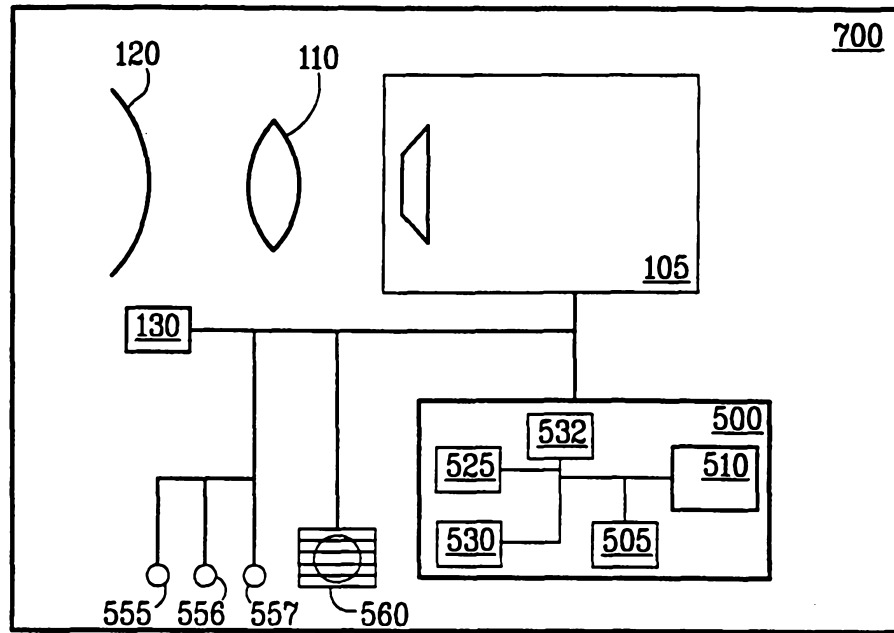
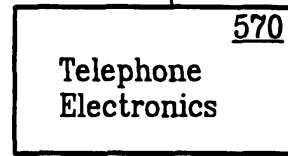

FIG. 9A



To Antenna



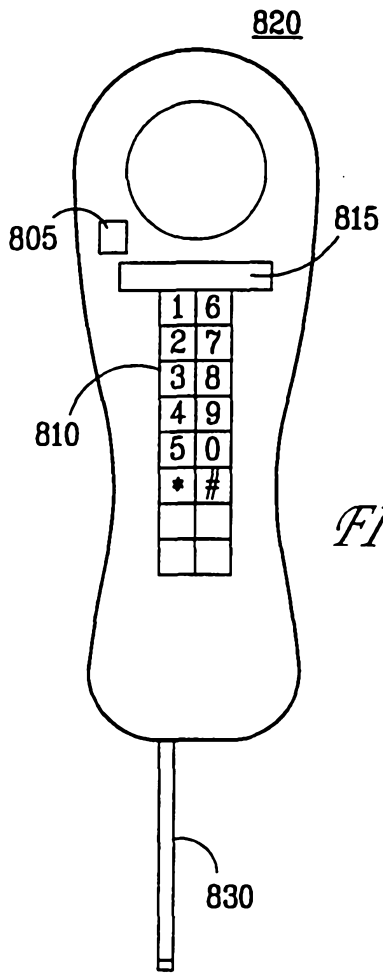

FIG. 9B

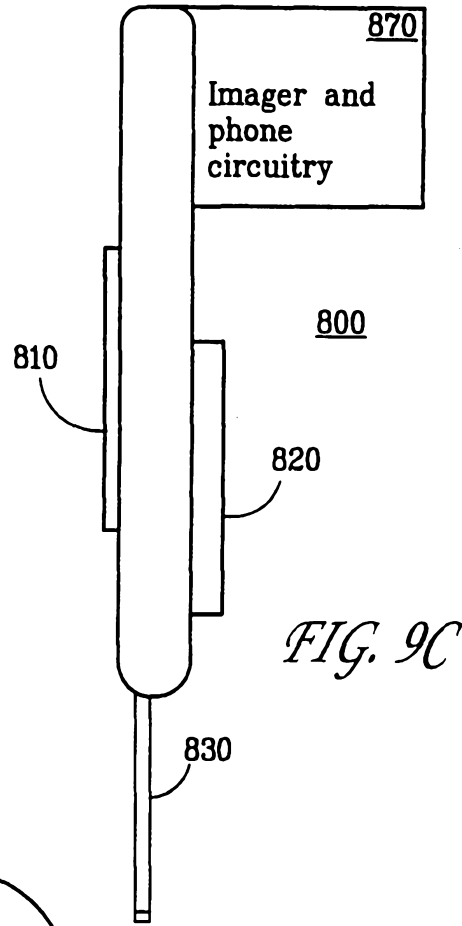

FIG. 9C

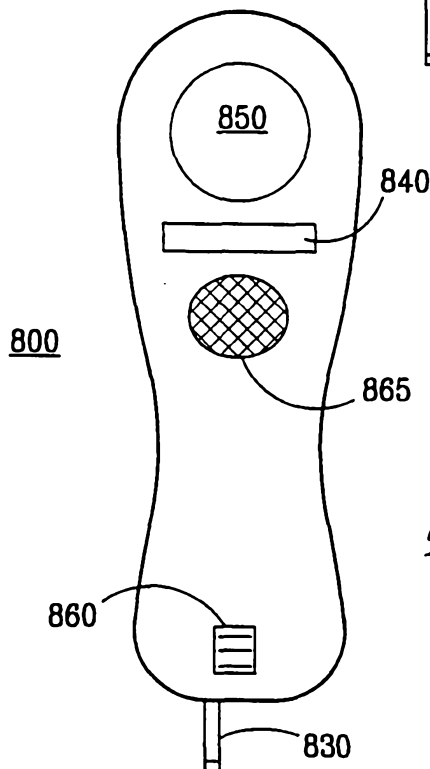

FIG. 9D

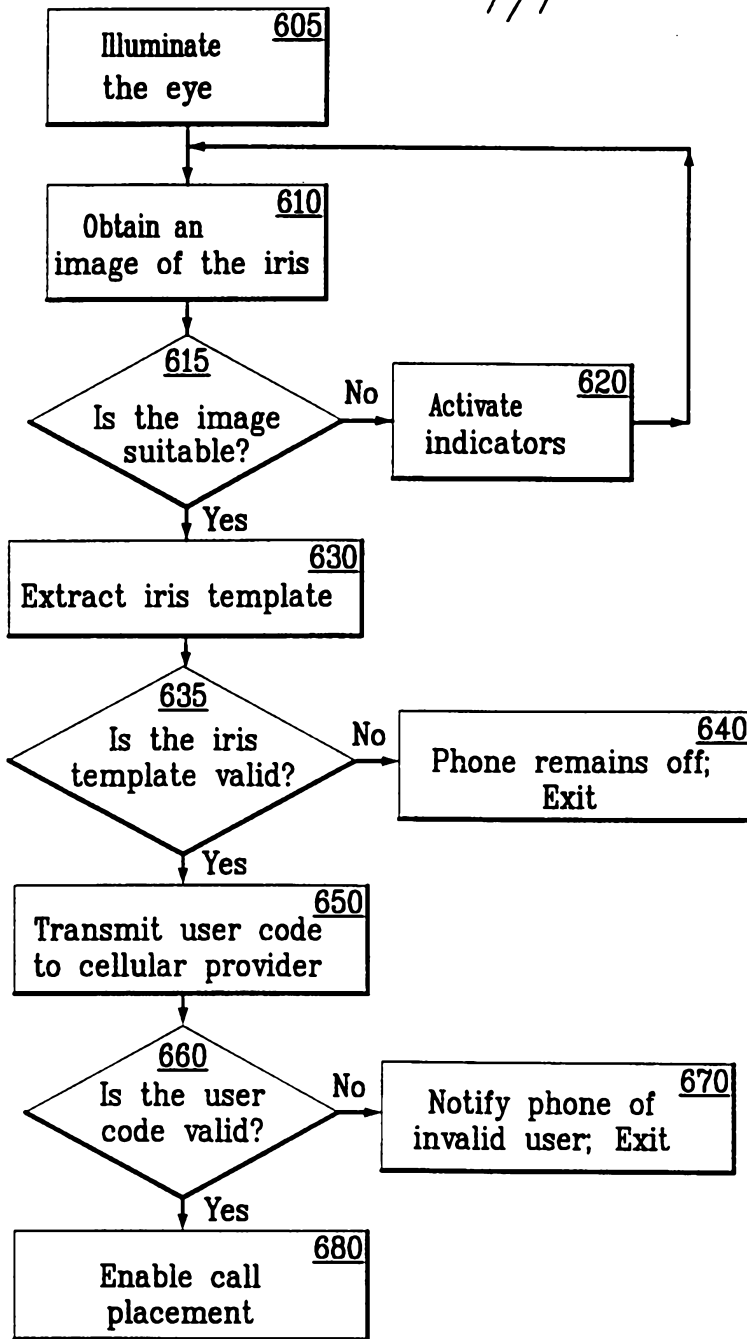

FIG. 10

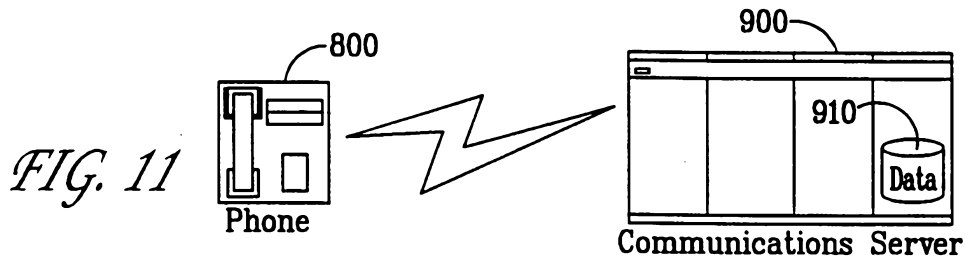

FIG. 11