

PCT

WORLD INTELLECTUAL PROPERTY
International Union for the Protection of Intellectual Property

INTERNATIONAL APPLICATION PUBLISHED UNDER THE ARRANGEMENTS OF THE

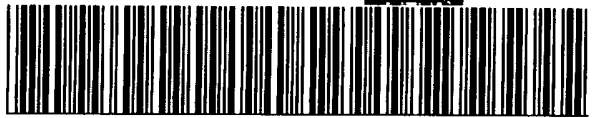

(51) International Patent Classification ⁶ :
A21C 11/00, 11/08

A1

(11) WO 9608971A1
(43) International Publication Date: 28 March 1996 (28.03.96)

(21) International Application Number: PCT/US94/10476

(22) International Filing Date: 19 September 1994 (19.09.94)

(71) Applicant (for all designated States except US): GENERAL MILLS, INC. [US/US]; Number One General Mills Boulevard, P.O. Box 1113, Minneapolis, MN 55440 (US).

(72) Inventors; and

(75) Inventors/Applicants (for US only): BENHAM, Richard, O. [US/US]; 8208 - 28th Avenue North, New Hope, MN 55427 (US). BRUNKEN, Sheryl, S. [US/US]; 108 - 14th Street, Delano, MN 55328 (US). DECHAINED, Robert, C. [US/US]; 3030 Wisconsin Avenue North, Crystal, MN 55427 (US). GLUSZAK, Timothy, J. [US/US]; Apartment 1209, 6418 City West Parkway, Eden Prairie, MN 55344 (US). SMETHERS, Rene, K. [US/US]; 3132 Georgia Avenue North, Crystal, MN 55427 (US). ZIMMERMANN, Craig, E. [US/US]; 140 East Lake Street, Waconia, MN 55387 (US).

(74) Agents: O'TOOLE, John, A. et al.; General Mills, Inc., P.O. Box 1113, Minneapolis, MN 55440 (US).

(81) Designated States: AM, AT, AU, BB, BG, BR, BY, CA, CH, CN, CZ, DE (Utility model), DK, EE, ES, FI, GB, GE, HU, JP, KE, KG, KP, KR, KZ, LK, LR, LT, LU, LV, MD, MG, MN, MW, NL, NO, NZ, PL, PT, RO, RU, SD, SE, SI, SK, TJ, TT, UA, US, UZ, VN, European patent (AT, BE, CH, DE, DK, ES, FR, GB, GR, IE, IT, LU, MC, NL, PT, SE), OAPI patent (BF, BJ, CF, CG, CI, CM, GA, GN, ML, MR, NE, SN, TD, TG), ARIPO patent (KE, MW, SD).

Published

With international search report.

(54) Title: FOOD ITEM FABRICATING APPARATUS AND METHODS

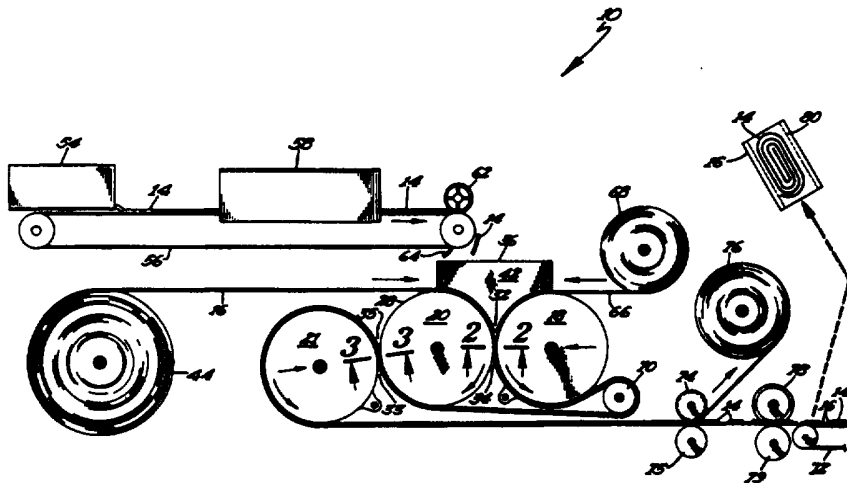

(57) Abstract

Apparatus (10) is disclosed including first and second forming rollers (18, 21) which rotatably abut with an anvil roller (20). The forming rollers (18, 21) each include a periphery forming a continuous forming surface including a plurality of axially and circumferentially spaced grooves (24) each formed as a continuous depression arranged in a serpentine and non-intersecting manner. Food (14) is simultaneously fed between a continuous strip of support material (16) and a continuous ribbon of film material (66) as they pass between a first abutment nip of the first forming roller (18) and the anvil roller (20). After extending partially around the periphery of the first forming roller (18), the materials (16, 66) and the food therebetween pass around an adjustable idler roller (70) to between a second abutment nip of the second forming roller (21) and the anvil roller (20). The food (14) compressed upon the support material (16) by the first abutment nip is in phase with the grooves (24) of the second abutment nip. The film material (66) removes the food (14) from the grooves (24) and can be discarded after passing through the second abutment nip and prior to the support material (16) being cut to longitudinal lengths and widths between the embossed shapes of food (14).

FOR THE PURPOSES OF INFORMATION ONLY

Codes used to identify States party to the PCT on the front pages of pamphlets publishing international applications under the PCT.

AT	Austria	GB	United Kingdom	MR	Mauritania
AU	Australia	GE	Georgia	MW	Malawi
BB	Barbados	GN	Guinea	NE	Niger
BE	Belgium	GR	Greece	NL	Netherlands
BF	Burkina Faso	HU	Hungary	NO	Norway
BG	Bulgaria	IE	Ireland	NZ	New Zealand
BJ	Benin	IT	Italy	PL	Poland
BR	Brazil	JP	Japan	PT	Portugal
BY	Belarus	KE	Kenya	RO	Romania
CA	Canada	KG	Kyrgystan	RU	Russian Federation
CF	Central African Republic	KP	Democratic People's Republic of Korea	SD	Sudan
CG	Congo	KR	Republic of Korea	SE	Sweden
CH	Switzerland	KZ	Kazakhstan	SI	Slovenia
CI	Côte d'Ivoire	LI	Liechtenstein	SK	Slovakia
CM	Cameroon	LK	Sri Lanka	SN	Senegal
CN	China	LU	Luxembourg	TD	Chad
CS	Czechoslovakia	LV	Latvia	TG	Togo
CZ	Czech Republic	MC	Monaco	TJ	Tajikistan
DE	Germany	MD	Republic of Moldova	TT	Trinidad and Tobago
DK	Denmark	MG	Madagascar	UA	Ukraine
ES	Spain	ML	Mali	US	United States of America
FI	Finland	MN	Mongolia	UZ	Uzbekistan
FR	France			VN	Viet Nam
GA	Gabon				

-1-

1 Food Item Fabricating Apparatus and Methods

BACKGROUND

 The present invention generally relates to apparatus
and methods for fabricating food items, and particularly
5 to apparatus and methods for fabricating food items
including food of a desired embossed shape supported on
support material.

 The sale of snack-type food products is a highly
competitive business. In addition to the particular food
10 components, increasingly the novelty and play value of
the product are important in the marketability of any
particular food item. For example, fruit-based snack
products such as FRUIT ROLL-UPS™ and FRUIT-BY-THE-FOOT™
fruit products have found wide market acceptance.

15 Accordingly, it is an object of the present invention
to provide novel apparatus and methods for the fabrication
of food items, which in the preferred form are in the form
of a continuous string of food supported upon a relatively

-2-

1 rigid strip of support material in a non-intersecting
arrangement.

Another object of the invention is to provide
apparatus and methods where the food is compressed as
5 strings on the support material without a thin layer of
food being present on the support material and between the
desired shape of food.

SUMMARY

Surprisingly, the above objectives can be satisfied
10 in the field of food fabrication by providing, in the
preferred form, apparatus and methods of food fabrication
where a strip of support material and food are
simultaneously fed between an anvil surface and a
continuous forming surface of a first abutment nip to
15 compress the food into a groove in the desired food shape
and onto the support material and then passing the support
material between a second abutment nip having a correspond-
ing groove in its continuous forming surface and in phase
with the food compressed on the continuous strip of
20 support material.

In preferred aspects of the present invention, the
first and second abutment nips are formed by first and
second forming rollers rotatably abutting different
portions of the periphery of an anvil roller.

25 In other aspects of the present invention, the phase
of the continuous strip of support material and the food
compressed thereon can be adjusted by changing the spacing
of an idler roller which strips the continuous strip of
support material and the food compressed thereon from the
30 first forming roller.

In still other aspects of the present invention, a
ribbon of film material is utilized to remove the
compressed food from the grooves of the forming roller,
with the ribbon of film material located intermediate the
35 food and the forming rollers.

The present invention will become clearer in light of
the following detailed description of an illustrative

-3-

1 embodiment of this invention described in connection with
the drawings.

DESCRIPTION OF THE DRAWINGS

The illustrative embodiment may best be described by
5 reference to the accompanying drawings where:

Figure 1 shows a diagrammatic, side elevational view
of an apparatus for fabricating a food item according to
the preferred teachings of the present invention, with a
food item being exploded and turned therefrom.

10 Figure 2 shows a partial, cross-sectional view of the
apparatus of Figure 1 according to section line 2-2 of
Figure 1.

Figure 3 shows a partial, cross-sectional view of the
apparatus of Figure 1 according to section line 3-3 of
15 Figure 1.

Figure 4 shows a diagrammatic, partial, end elevational
view of the strings of food compressed on a sheet of
support material by the apparatus of Figure 1, with the
ribbon of film material and a forming roller shown in
20 phantom being exploded therefrom.

Figure 5 shows a diagrammatic, cross-sectional view of
the food item formed by the apparatus of Figure 1.

All figures are drawn for ease of explanation of the
basic teachings of the present invention only; the
25 extensions of the Figures with respect to number,
position, relationship, and dimensions of the parts to
form the preferred embodiment will be explained or will
be within the skill of the art after the following
teachings of the present invention have been read and
30 understood. Further, the exact dimensions and
dimensional proportions to conform to specific force,
weight, strength, and similar requirements will likewise
be within the skill of the art after the following
teachings of the present invention have been read and
35 understood.

Where used in the various figures of the drawings,
the same numerals designate the same or similar parts.

-4-

1 Furthermore, when the terms "first", "second", "lower",
"upper", "end", "axial", "longitudinal", "width",
"height", and similar terms are used herein, it should be
understood that these terms have reference only to the
5 structure shown in the drawings as it would appear to a
person viewing the drawings and are utilized only to
facilitate describing the invention.

DESCRIPTION

An apparatus utilizing methods for fabricating a food
10 item on a continuous strip of support material according
to the preferred teachings of the present invention is
shown in the drawings and generally designated 10. The
food item generally includes a food 14 of any desired
embossed shape supported on support material 16. In the
15 preferred form, food 14 is in the form of a continuous
string or rope of material in a nonintersecting arrangement
such as an outwardly expanding spiral race track design as
shown. In the preferred form, food 14 is a fruit-based
material and in the most preferred form is in the form of
20 a composition including a fruit base such as grape juice
or pear concentrate and a gum system. In the most
preferred form, fruit puree is absent from the composition.
Support material 16 may be formed of any suitable material
such as cardboard which has the necessary strength to
25 support food 14 without tearing and without bulkiness to
allow compression of food 14 onto support material 16 and
which allows food 14 to be easily separated therefrom for
consumption.

Apparatus 10 generally includes three rollers 18, 20
30 and 21. In the preferred form, rollers 18, 20 and 21 will
have a tendency to be heated by food 14 and are cooled by
any suitable means, not shown, such as by circulating
water in the most preferred form and less preferably by
pulsating cool water. In the preferred form, roller 18
35 is cooled to a temperature greater than 90°F (32°C) and
preferably in the order of 120°F (49°C) by circulating warm
water having a temperature in the order of 110°F (43°C).

-5-

1 In the preferred form, rollers 20 and 21 are cooled to a
temperature in the order of 40°F (4°C) by circulating cold
water having a temperature in the order of 36°F (2°C).

The periphery defining a continuous forming surface of
5 each forming roller 18 and 21 is grooved and specifically
includes a plurality of circumferentially and axially
spaced patterns. Each pattern includes one or more
depressions or grooves 24, with lands 22 located between
grooves 24 in each pattern and also separating the
10 patterns from each other. The width of depressions or
grooves 24 is generally equal to the desired width of the
strings of food 14 and the height of lands 22 or in other
words the depth of depressions or grooves 24 is generally
equal to the desired thickness of the strings of food 14.
15 The width of grooves 24 decreases from the peripheries
of rollers 18 and 21 towards the center of rollers 18 and
21, with the side walls forming grooves 24 being non-
parallel and having an angle greater than 15° relative to
each other and in the most preferred form in the order of
20 20° to 30°. In the most preferred form, the depth of
grooves 24 in roller 21 is slightly greater and in the most
preferred form is 40% greater than the depth of grooves
24 in roller 18. The axial width of lands 22 between the
patterns is generally equal to the desired lateral spacing
25 between the strings of food 14 and the circumferential
width of lands 22 between the patterns is generally equal
to the desired longitudinal spacing between the strings of
food 14. In the most preferred form, grooves 24 of roller
18 have a width in the order of 0.178 inch (0.452 cm) and
30 a depth in the order of 0.125 inch (0.318 cm), with the
width of lands 22 between grooves 24 in each pattern
being in the order of 0.058 inch (0.147 cm). Grooves 24
of roller 21 have a width in the order of 0.196 inch
(0.498 cm) and a depth in the order of 0.176 inch
35 (0.447 cm), with the width of lands 22 between grooves
24 in each pattern being in the order of 0.040 inch
(0.102 cm). The patterns can be of the same or different

-6-

1 configurations, but each pattern on roll 18 has a
corresponding pattern at complementary axial and
circumferential positions on roller 21.

Anvil roller 20 includes a cylindrical periphery 28
5 defining a continuous anvil surface which is relatively
smooth in the most preferred form. Rollers 18 and 20 are
rotatably mounted about parallel axes in an abutting
relation, with periphery 28 of roller 20 engaging, rolling
upon and movable relative to lands 22 of roller 18 along
10 an abutment nip. Likewise, rollers 20 and 21 are
rotatably mounted about parallel axes in an abutting
relation, with periphery 28 of roller 20 engaging, rolling
upon and movable relative to lands 22 of roller 21 along
an abutment nip. The nip pressure between rollers 18 and
15 20 and rollers 20 and 21 is 1,000-2,000 psi (70-140 kg/cm²)
in the most preferred form and is obtained utilizing
hydraulic pressure to bias rollers 18 and 21 against
roller 20. In the most preferred form, rollers 18, 20 and
21 are generally cylindrical and of equal diameters. The
20 axes of rollers 18 and 20 are horizontally offset from
each other, with the axis of roller 21 being vertically
offset below the axis of roller 20 and horizontally offset
from the axis of roller 20 on the side opposite roller 18.
The anvil surfaces of the first and second abutment nips
25 between rollers 18, 20 and 21 are located at different
portions of periphery 28 of roller 20 and at portions
which are less than 180° apart in the most preferred form.
Rollers 18 and 20 are rotated in opposite rotational
directions to define an upper, mating side 32 and a lower,
30 exit side 34. Similarly, rollers 20 and 21 are rotated in
opposite rotational directions to define a lower, feed
side 33 and an upper, exit side 35. To allow cleaning,
rollers 18 and 21 may be movably mounted relative to and
loaded against roller 20 such as by pivotable mounting to
35 allow separation of rollers 18 and 21 from roller 20.

Food 14 is filled into upper mating side 32, with a
containment saddle 36 being provided complementary to and

-7-

1 for holding food 14 above and evenly feeding material to
and within mating side 32. In the preferred form, saddle
36 includes end pieces 42 extending radially between and
engaging the peripheries of rollers 18 and 20. In the
5 most preferred form, end pieces 42 extend generally
perpendicular to the rotational axes of rollers 18 and 20.

Food 14 in the most preferred form is extruded from an
extruder 54 in the form of a single extrudiate rope on a
conveyor 56 in the most preferred form at a temperature in
10 the order of 200°F (93°C). While on conveyor 56, food 14
passes through an air impingement cooling tunnel 58 to
cool the food to a temperature where food 14 is plastic
but not flowable and in the most preferred form in the
order of 160-170°F (71-77°C). After cooling tunnel 58 and
15 prior to but closely adjacent the end of conveyor 56, the
extrudiate rope of food 14 is cut by a rotating, helical
reel type cutter 64 into small segments of a few inches or
centimeters in length. Due to the helical nature of the
blades of cutter 64, the segments of food 14 are pushed
20 from a linear relation with the extrudiate rope to prevent
the ends of the segments of food 14 from reattaching to
reform a rope. After cutter 64, the segments of food 14
are allowed to fall by gravity into saddle 36, with any
segments of food 14 which adhere to conveyor 56 being
25 scraped therefrom such as by a scraper 64. In the most
preferred form, conveyor 56 is positioned above and
parallel to the axes of rollers 18 and 20.

Support material 16 typically is supplied from a roll
44 and is threaded to extend over periphery 28 of roller
30 20 located within saddle 36 and mating side 32, and to
extend between the nip of rollers 18 and 20 into exit
side 34.

A continuous ribbon of thin film material 66 is
typically supplied from a roll 68 and is threaded to
35 extend over lands 22 and grooves 24 of the periphery of
roller 18 located within saddle 36 and mating side 32,
and to extend between the nip of rollers 18 and 20 into

-8-

1 exit side 34. Film material 66 in the preferred form is
a plastic material having a low memory and either having
characteristics or suitably coated for ease of removal
from food 14.

5 Food 14 is initially located in mating side 32
intermediate support material 16 and film material 66
supported by rollers 20 and 18, respectively. It can then
be appreciated that as food 14 and material 16 and 66 are
pulled and simultaneously fed between the abutment nip
10 between rollers 18 and 20 by the rotation of rollers 18
and 20, food 14 and material 66 advancing between rollers
18 and 20 will be compressed into grooves 24 such that
food 14 will be deposited in the shapes of the pattern
formed by grooves 24 upon support material 16, with the
15 width and height of the strings of food 14 generally
corresponding to the width and depth of grooves 24.
Depending upon several factors, food 14 and material 66
may not be forced to entirely fill grooves 24 as
diagrammatically shown in the drawings, with such a result
20 clearly being desired at least for consistency in the
amount of food 14 compressed on support 16. Rather, food
14 and material 66 may not be forced into the corners of
grooves 24 such that food 14 at locations spaced from
support 16 will have a more rounded configuration.

25 It can then be appreciated that if food 14 were fed
into saddle 36 as an extrudate rope, a tendency may exist
for the rope to coil upon itself as it falls into saddle 36
creating air spaces or gaps which may prevent food 14 from
filling cavities 24. According to the preferred teachings
30 of the present invention, feeding food 14 in the form of
segments prevents such coiling and the air spaces created
thereby such that consistent filling of cavities 24 is
obtained as the food segments tend to be self-distributing.
Thus, less operator attention and monitoring is required
35 for apparatus 10 according to the preferred teachings of
the present invention.

-9-

1 It should also be appreciated that if food 14 is fed
to mating side 32 in a too-hot, flowable condition, food
14 may not be able to compress material 66 completely into
grooves 24 resulting in food 14 having a width and depth
5 substantially less than that of grooves 24. Similarly,
if food 14 is fed to mating side 32 in a too-cold, waxy
condition, food 14 may not be pulled between the abutment
nip between rollers 18 and 20 to fill grooves 24 and thus
also resulting in food 14 having a width and depth
10 substantially less than that of grooves 24. Likewise,
if rollers 18 and 21 are too hot, material 66 may have
a tendency to rip as it is compressed into grooves 24.
Further, the nip pressure between rollers 18, 20, and 21
is important to push food 14 into grooves 24 and overcome
15 the stretch resistance of material 66 of being compressed
into grooves 24 and to minimize or prevent flashing by
food passing between the peripheries of rollers 18, 20,
and 21 intermediate grooves 24 and being evidenced by a
thin film on support material 16 between the strings of
20 food.

Apparatus 10 according to the preferred teachings of
the present invention further includes an idler roller 70
having a smooth periphery and an axial length generally
equal to that of rollers 18, 20 and 21 and the lateral
25 width of the web support material 16. The diameter of
roller 70 is substantially less than and in the most
preferred form one-fifth the diameter of rollers 18, 20
and 21. The axis of roller 70 is parallel to the axes of
rollers 18, 20 and 21 and vertically offset below the axis
30 of roller 18 generally equal to the radius of roller 18.
The axis of roller 70 is horizontally offset from the
axis of roller 18 on the side opposite rollers 20 and 21
slightly larger than the radius of roller 18, with at
least the horizontal offset of roller 70 being adjustable.

35 In exit side 34 after the abutment nip between rollers
18 and 20, support material 16 with food 14 and material
66 sandwiched against roller 18 will extend around

-10-

1 slightly greater than 90° of the periphery of roller 18
to separate support material 16 from roller 20 and then
extend generally tangentially from roller 18. As support
material 16 separates from roller 18, material 66 will
5 pull food 14 from grooves 24 of roller 18. It can then be
appreciated that material 66 must have sufficient strength
to pull food 14 from grooves 24 without tearing or breaking
but have sufficient stretchability and flexibility to
allow food 14 to be compressed into grooves 24 in the
10 abutment nip of a volume generally equal to that of
grooves 24. Additionally, film material 66 has a low
resiliency or memory which does not tend to smash food 14
undesirably deforming the shape of food 14 after leaving
forming rollers 18 and 21. Specifically, in the most
15 preferred form, the ribbon of film material 66 has a low
tensional strength and particularly in the most preferred
form will stretch 110% due to the application of a force
of less than one pound (0.4536 kg) utilizing the tensional
properties of thin plastic sheeting test procedure of
20 ASTM D882. If material 66 had greater tensional strength,
less food 14 would be compressed in grooves 24 and thus
compressed on support material 16. In the most preferred
form, film material 66 is formed of linear low density
polyethylene having a thickness in the order of 0.0005
25 inches (0.0127 mm). Thicker films tend to have greater
tensional strengths, but films thicker than the preferred
form might work if possessing the relatively low tensional
strength required according to the preferred teachings of
the present invention. The diametric size and positioning
30 of roller 70 as disclosed is also important in the ability
of material 66 to remove food from grooves 24 of roller 18.
It is also believed that the sudden pressure differential
between above the nip abutment where food 14 is under
pressure as it is compressed into grooves 24 and below the
35 nip abutment where food 14 is not under pressure as it
passes the nip abutment tends to pop or remove the food
from grooves 24 of roller 18.

-11-

1 Food 14 and material 16 and 66 extends around over 180°
of roller 70 such that it is inverted and extends towards
rollers 20 and 21, with material 66 holding food 14
against the lower surface of material 16. Material 16
5 engages periphery 28 of roller 20 generally at a point
vertically below the axis of roller 20 and extends on
periphery 28 for generally 90° into feed side 33 and
passes between the abutment nip between rollers 20 and 21.
When entering the abutment nip, material 66 and food 14
10 enters grooves 24 of roller 21, with grooves 24 further
compressing food 14 into the shape of the particular
pattern. It was found that compressing food 14 between a
single pair of rollers 18 and 20 results in a thin film of
food being present upon support material 16 between lands
15 22 and periphery 28 and between the desired shape of food
14 formed by grooves 24. Compressing food 14 between a
second pair of rollers 20 and 21 results in food 14 being
in the desired shape of food 14 formed by grooves 24 and
generally without food being present upon support material
20 16 in the form of thin film or flashing between lands 22
and periphery 28.

It can be appreciated that food 14 and material 16
and 66 should enter mating side 33 of rollers 20 and 21
generally in phase with grooves 24 of roller 21. It can
25 then be appreciated that roller 70 can be moved to adjust
the phase of food 14 and material 16 and 66 to match that
of grooves 24 of roller 21, with adjustment being
dependent upon several factors including the stretch-
ability of material 16, the tension placed upon material
30 16 and like factors.

After the abutment nip between rollers 20 and 21,
support material 16 with food 14 and material 66 sandwiched
against roller 21 extends through exit side 35 and slightly
greater than 270° of the periphery of roller 21. Apparatus
35 10 in the most preferred form further includes a pair of
counter rotating rollers 74 and 75 having vertically
spaced, parallel axes parallel to and spaced from the axes

-12-

1 of rollers 18, 20, 21 and 70. In the most preferred form,
roller 75 is a steel roller including a smooth periphery
and roller 74 is a rubber coated steel roller including
a plurality of lands which roll on material 66 and 16
5 laterally intermediate the strings of food 14 on material
16, with the depths of the grooves between the lands
being at least equal to or greater than the height of
food 14 on support material 16. Support material 16
with food 14 and material 66 thereon extends from the
10 periphery of roller 21 horizontally below rollers 18, 20,
21 and 70 due to the vertical offset of roller 21 below
rollers 18 and 20 and between the abutment nip of rollers
74 and 75 for pulling upon support material 16. Material
66 extends generally tangentially from roller 74 to a
15 rotated take-up roll 76 at an acute angle in the order
of 45° from support material 16 and food 14 extending
generally horizontally from rollers 74 and 76. After
material 66 has been removed, support material 16 is cut
into segments such as by one or more pairs of cutting
20 rollers 78 and 79 to longitudinal lengths and widths
between the embossed shapes of food 14. In the most
preferred form, support material 16 in addition to being
cut to width is perforated at 80 to form flaps having a
height generally equal to food 14 which can be folded
25 upward. After cutting to longitudinal lengths by rollers
78 and 79, the individual food items are transferred to a
vacuum conveyor 72 for further processing. For example,
after cutting and folding, the individual food item can
be suitably packaged in a wrapper 82 shown in phantom in
30 Figure 5 and placed in cartons including the desired
number of food items.

The food items fabricated with apparatus 10 according
to the methods of the preferred teachings of the present
invention generally include support 16 formed of a
35 generally rigid material and specifically 12 or 14 point
cardboard of a size of 6.8 inch (17.3 cm) by 2.3 inch
(5.8 cm) in the most preferred form. The continuous

-13-

1 string of food 14 has first and second, opposite, free
ends having an elongated length between the ends
substantially greater than the length and width of support
16 and specifically in the order of 54 inches (137 cm).
5 Thus, food 14 has a range density of 3-4 linear inch per
square inch (1.2-1.6 linear centimeter per square
centimeter) and in the most preferred form in the order
of 3.3 linear inch per square inch (1.3 linear centimeter
per square centimeter) of support 16. The continuous
10 string of food 14 is removably adhered to the planar upper
surface of support 16 in a serpentine and non-intersecting
manner. Thus, a consumer can gradually peel the
continuous string of food 14 from support 16 while the
unpeeled portions remain adhered to support 16 to enhance
15 the play value of the food item. Furthermore, the
arrangement of the continuous string of food 14 on
support 16 can be varied both in general appearance such
as between an outwardly expanding spiral race track design
as diagrammatically shown in Figure 1, an eyeglass design,
20 or other design and/or in the manner that the particular
design changes as the continuous string of food 14 is
peeled from support 16 and thus increasing the novelty
of the food item.

The upper surface of support 16 should include a
25 suitable coating such that food 14 adheres thereto during
fabrication, packaging, storage, and other handling but
can be generally readily removed therefrom when pulled and
without fracturing or otherwise breaking the continuous
nature of the string of food 14. In the most preferred
30 form, support 16 includes an extrusion coated, nylon based
release coating having a tack release factor characterized
by a very low surface energy value. If the surface energy
value of support 16 is too high in the order of 30 dynes/cm,
the continuous string of food 14 can not be readily removed
35 from support 16. On the other hand, if the surface energy
value of support 16 is too low in the order of 15 dynes/cm
such as used for the support material in the FRUIT-BY-THE-
FOOT™ fruit products, the continuous string of food 14

-14-

1 tends to come off all in one piece rather than in a manner
allowing the continuous string of food to be gradually
peeled from support 16 according to the preferred teachings
of the present invention. Thus, in the most preferred form,
5 the surface energy value of the release coating should be
in the range of 15 to 30 dynes/cm, particularly in the
order of 20-25 dynes/cm and in the most preferred form in
the order of 23-25 dynes/cm. Additionally, the coverage
factor must be high and specifically the release coating
10 should cover at least 90% and preferably greater than or
equal to 95% and for best results approximately 100% of
the surface area of the upper surface of support 16. Food
14 tends to adhere to paper fibers forming support 16
which are not coated by the release coating making removal
15 of those portions difficult.

In the most preferred form, a gram of food 14 is
formed into 3 to 10 centimeters and in the most preferred
form in the order of 6.5 centimeters of length of string
of food 14. If the weight versus length ratio is too
20 low, the string of food 14 will tend to tear as it is
pulled from support 16 and if too high will tend to pull
off as a single piece from support 16. It can then be
appreciated that the weight versus length ratio is
related to the width of food 14 at support 16 and the
25 thickness or height of food 14 in a direction generally
perpendicular to support 16, with the width and height of
food 14 in the string being generally equal in the most
preferred form and in the order of 3-4 millimeters and in
the most preferred form about 3.2 millimeters.

30 The use of three rollers 18, 20 and 21 to form the
first and second abutment nips according to the preferred
teachings of the present invention is believed to be
advantageous over forming the first and second abutments
from first and second pairs of rollers. Specifically, the
35 number of parts required in apparatus 10 is reduced thus

-15-

1 reducing capital and operating costs as well as reduction
in the overall size of apparatus 10. Further, lateral
tracking, i.e. in a direction perpendicular to the
movement of materials 16 and 66, is believed to be easier
5 to obtain when a single anvil roller 20 is utilized.

It is believed that fabrication of the food item
according to the preferred teachings of the present
invention is advantageous over other fabrication
techniques such as injection molding including at least
10 due to continuous fabrication reasons resulting in reduced
costs and greater capacities.

Likewise, although it is believed that the arrangement
of food 14 as a continuous string in a serpentine and non-
intersecting manner is advantageous at least due to the
15 novelty and play value of the product, food 14 can have
other arrangements such as but not limited to a continuous
string in an intersecting manner or other shapes according
to the preferred teachings of the present invention.

Thus since the invention disclosed herein may be
20 embodied in other specific forms without departing from
the spirit or general characteristics thereof, some of
which forms have been indicated, the embodiments
described herein are to be considered in all respects
illustrative and not restrictive. The scope of the
25 invention is to be indicated by the appended claims,
rather than by the foregoing description, and all changes
which come within the meaning and range of equivalency of
the claims are intended to be embraced therein.

-16-

What is claimed is:

1. Method of fabricating a food item including a food in a shape supported upon a support material comprising the steps of: providing a continuous strip of support material; passing the continuous strip of support material between a first abutment nip including an anvil surface and a continuous forming surface movable relative to the anvil surface, with the forming surface including at least a first groove having the food shape; simultaneously feeding food between the first abutment nip with the continuous strip of support material to compress the food into the groove of the forming surface; passing the continuous strip of support material having the food compressed thereon by the first abutment nip between a second abutment nip including an anvil surface and a continuous forming surface including at least a first groove having the food shape, with the groove of the second abutment nip being in phase with the food compressed on the continuous strip of support material; and cutting the continuous strip of support material into segments after passing through the second abutment nip.
2. The method of claim 1 wherein the simultaneously feeding step comprises the step of simultaneously feeding food intermediate the continuous strip of support material and the continuous forming surface of the first abutment nip.
3. The method of claim 2 further comprising the step of rotating an anvil roller having a periphery, with the anvil surface of the first abutment nip located at a portion of the periphery of the anvil roller and the anvil surface of the second abutment nip located at a different portion of the periphery of the anvil roller.
4. The method of claim 3 further comprising the step of adjusting the phase of the groove of the second abutment nip to match the phase of the food compressed on the continuous strip of support material.
5. The method of claim 4 further comprising the step of rotating first and second forming rollers with the anvil roller, with the continuous forming surface of the first abutment nip located on the first forming roller and the

-17-

continuous forming surface of the second abutment nip located on the second forming roller.

6. The method of claim 5 further comprising the step of passing the continuous strip of support material having the food compressed thereon after the first abutment nip and prior to the second abutment nip around an idler roller to separate the continuous strip of support material having the food compressed thereon from the anvil surface and the continuous forming surface of the first abutment nip.

7. The method of claim 6 wherein the adjusting step comprises the step of adjusting the idler roller relative to the second abutment nip.

8. The method of claim 1 further comprising the step of passing a continuous ribbon of film material between the first abutment nip, with the continuous strip of support material located adjacent the anvil surface and the continuous ribbon of film material located adjacent the continuous forming surface; and wherein the simultaneously feeding step comprises the step of simultaneously feeding food between the continuous ribbon of film material and the continuous strip of support material, with the continuous ribbon of film material deflecting into the groove as the food is compressed into the groove.

9. The method of claim 8 further comprising the step of removing the continuous ribbon of film material from the continuous strip of support material and the food compressed thereon prior to the cutting step.

10. The method of claim 8 wherein the providing step comprises the step of providing the continuous strip of support material including an extrusion coated, nylon-based release coating having a tack release factor characterized by a surface energy value in the range of 15 to 30 dynes/cm; and wherein the step of passing the continuous ribbon of film material comprises the step of passing the continuous ribbon of film material formed of linear low density polyethylene having a low tensional force.

11. The method of claim 1 further comprising the step

-18-

of adjusting the phase of the groove of the second abutment nip to match the phase of the food compressed on the continuous strip of support material.

12. The method of claim 1 further comprising the step of passing the continuous strip of support material having the food compressed thereon after the first abutment nip and prior to the second abutment nip around an idler roller to separate the continuous strip of support material having the food compressed thereon from the anvil surface and the continuous forming surface of the first abutment nip.

13. The method of claim 12 further comprising the step of adjusting the idler roller relative to the second abutment nip to adjust the phase of the groove of the second abutment nip to match the phase of the food compressed on the continuous strip of support material.

14. The method of claim 1 wherein the simultaneous feeding step comprises the steps of: cutting a continuous rope of food into food segments; and simultaneously feeding the food segments between the first abutment nip.

15. The method of claim 1 wherein the passing steps each comprise the step of passing the continuous strip of support material between the abutment nip including the continuous forming surface having the first groove formed as a continuous depression having first and second opposite ends and arranged in a serpentine and non-intersecting manner in the continuous forming surface.

16. Apparatus for fabricating a food item including a food in a shape supported upon a support material comprising, in combination: a first abutment nip including an anvil surface and a continuous forming surface movable relative to the anvil surface, with the forming surface including at least a first groove having the food shape; a second abutment nip including an anvil surface and a continuous forming surface including at least a first groove having the food shape; means for providing a continuous strip of support material; means for simultaneously feeding food between the first abutment nip with the continuous strip of support

-19-

material to compress the food into the groove of the forming surface and for subsequently passing the continuous strip of support material having the food compressed thereon by the first abutment nip between the second abutment nip, with the groove of the second abutment nip being in phase with the food compressed on the continuous strip of support material; and means for cutting the continuous strip of support material into segments after passing through the second abutment nip.

17. The apparatus of claim 16 wherein the simultaneous feeding means comprises means for simultaneously feeding food intermediate the continuous strip of support material and the continuous forming surface of the first abutment nip.

18. The apparatus of claim 16 wherein the first abutment nip comprises a first forming roller having a periphery including the continuous forming surface, with the first forming roller being rotatable relative to the anvil surface.

19. The apparatus of claim 18 wherein the first abutment nip further comprises, in combination: an anvil roller having a periphery including the anvil surface.

20. The apparatus of claim 19 wherein the second abutment nip comprises a second forming roller having a periphery including the continuous forming surface, with the second forming roller being rotatable relative to the anvil surface.

21. The apparatus of claim 20 wherein the periphery of the anvil roller further includes the anvil surface of the second abutment nip.

22. The apparatus of claim 21 further comprising, in combination: an idler roller spaced from the first and second forming rollers and the anvil roller, with the continuous strip of support material extending tangentially from the first forming roller to the idler roller and then extending tangentially to the anvil roller.

23. The apparatus of claim 22 wherein the idler roller is adjustable relative to the first and second forming rollers to adjust the phase of the groove of the second

-20-

abutment nip to match the phase of the food compressed on the continuous strip of support material.

24. The apparatus of claim 16 further comprising, in combination: means for providing a continuous ribbon of film material, with the food being fed intermediate the continuous ribbon of film material and the continuous strip of support material, with the continuous ribbon of film material located intermediate the continuous strip of support material and the continuous forming surface.

25. The apparatus of claim 24 wherein the continuous strip of support material includes an extrusion coated, nylon-based release coating having a tack release factor characterized by a surface energy value in the range of 15 to 30 dynes/cm; and wherein the continuous ribbon of film material is formed of linear low density polyethylene having a low tensional force.

26. The apparatus of claim 24 further comprising, in combination: means for removing the continuous ribbon of film material from the continuous strip of support material and the food compressed thereon.

27. The apparatus of claim 16 further comprising, in combination: means for conveying a continuous rope of food; and means for cutting the continuous rope of food into food segments, with the food segments being fed between the first abutment nip.

28. The apparatus of claim 16 wherein the grooves of the forming surfaces are each formed as a continuous depression having first and second opposite ends and arranged in a serpentine and non-intersecting manner in the continuous forming surface.

29. Food item comprising, in combination: a support formed of a generally rigid material and having a length, a width, and an upper surface; and a continuous string of food having an elongated length substantially greater than the length and width of the support and having first and second, opposite, free ends, with the continuous string of food being removably adhered to the upper surface of the support

-21-

in a serpentine and non-intersecting manner.

30. The food item of claim 29 wherein the upper surface is planar.

31. The food item of claim 29 wherein the continuous string of food is formed with a fruit base and a gum system.

32. The food item of claim 31 wherein the upper surface of the support includes an extrusion coated, nylon-based release coating having a tack release factor characterized by a surface energy value in the range of 15 to 30 dynes/cm.

33. The food item of claim 32 wherein a gram of food is formed into 3 to 10 centimeters of continuous string, with 1.2 to 1.6 centimeters of continuous string of food being provided for each square centimeter of area of the upper surface of the support.

34. The food item of claim 33 wherein the continuous string of food has a width at the upper surface of the support and a height in a direction generally perpendicular to the upper surface of the support which are generally equal and in the order of 3 to 4 millimeters.

35. The food item of claim 29 wherein the support further includes first and second, parallel, spaced perforations to form flaps which can be folded at non-linear angles to the upper surface, with the continuous string of food located between the first and second perforations.

36. Food item comprising, in combination: a support formed of a generally rigid material and having a length, a width, and an upper surface, with the upper surface of the support including an extrusion coated, nylon-based release coating having a tack release factor characterized by a surface energy value in the range of 15 to 30 dynes/cm; and food removably adhered to the upper surface of the support.

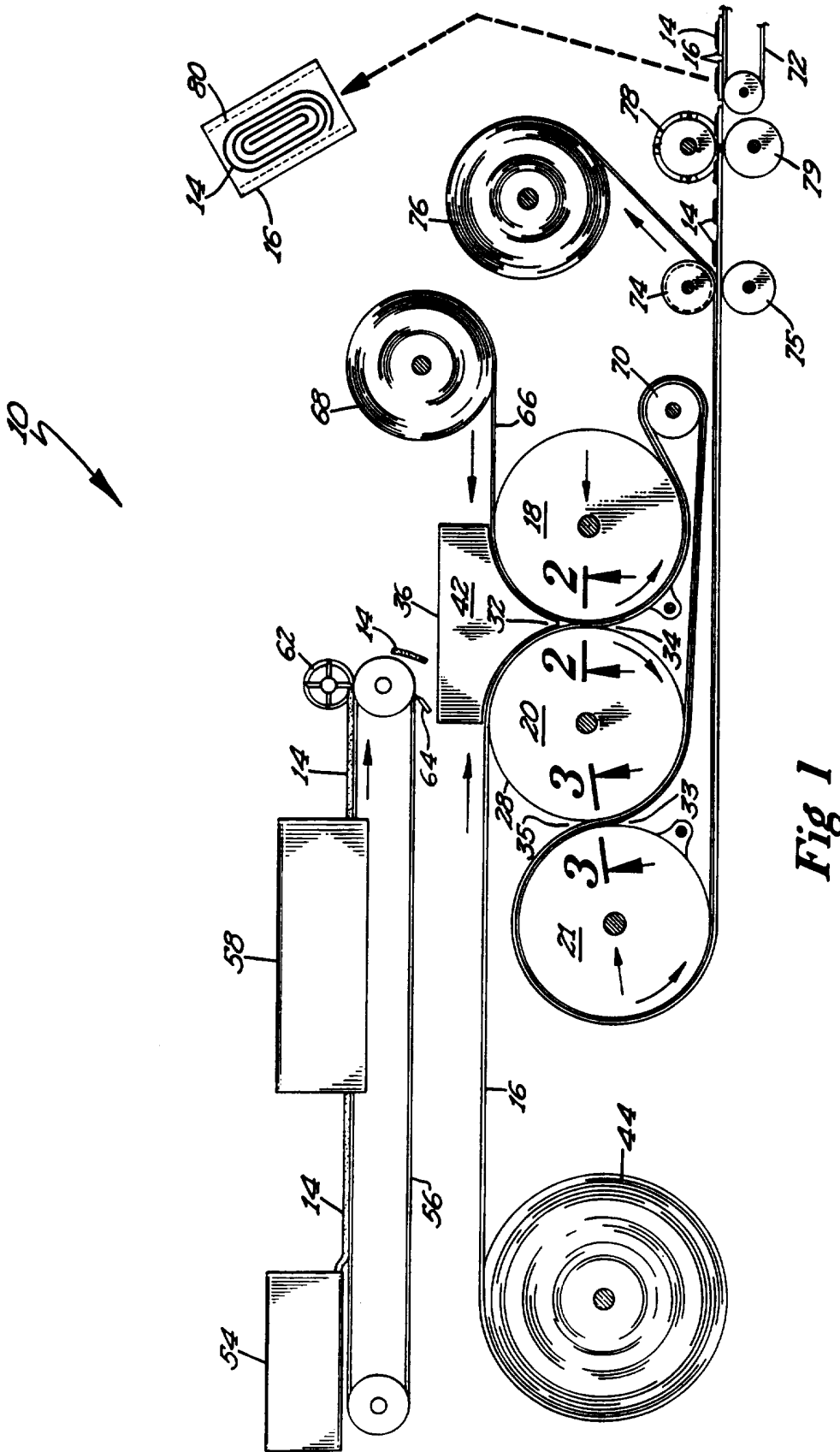

Fig 1

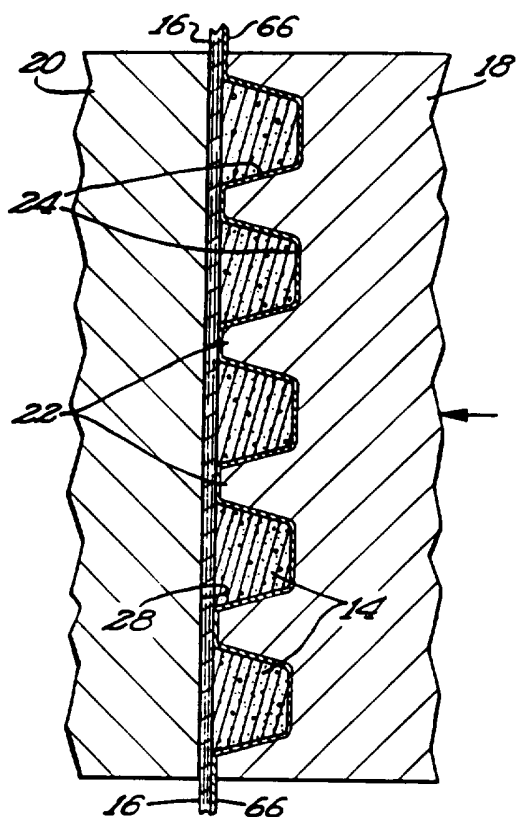

Fig 2

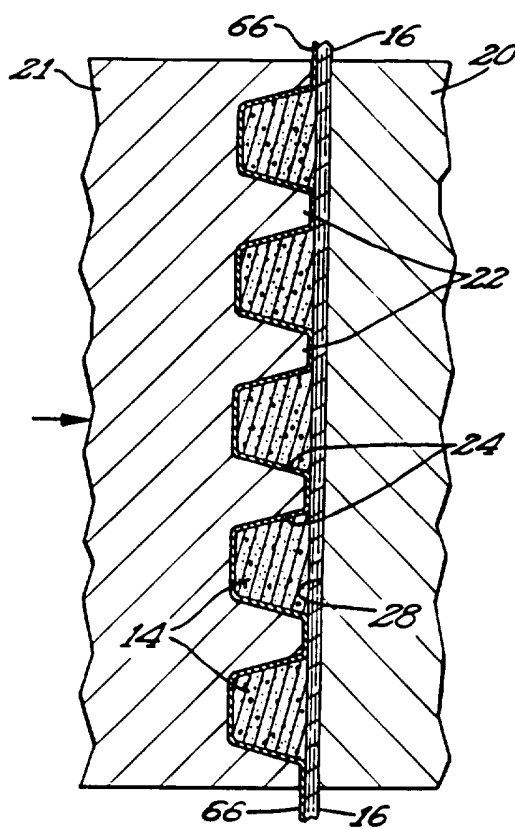

Fig 3

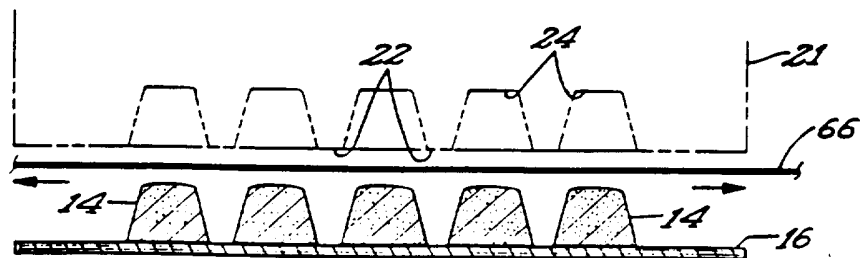

Fig 4

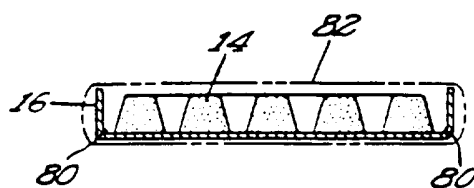

Fig 5

INTERNATIONAL SEARCH REPORT

Inter. Application No

PCT/US 94/10476

A. CLASSIFICATION OF SUBJECT MATTER
 IPC 6 A21C11/00 A21C11/08

According to International Patent Classification (IPC) or to both national classification and IPC

B. FIELDS SEARCHED

Minimum documentation searched (classification system followed by classification symbols)
 IPC 6 A21C

Documentation searched other than minimum documentation to the extent that such documents are included in the fields searched

Electronic data base consulted during the international search (name of data base and, where practical, search terms used)

C. DOCUMENTS CONSIDERED TO BE RELEVANT

Category *	Citation of document, with indication, where appropriate, of the relevant passages	Relevant to claim No.
A	US, A, 4 381 697 (W.G. CROTHERS) 3 May 1983 -----	

Further documents are listed in the continuation of box C.

Patent family members are listed in annex.

* Special categories of cited documents :

- *A* document defining the general state of the art which is not considered to be of particular relevance
- *E* earlier document but published on or after the international filing date
- *L* document which may throw doubts on priority claim(s) or which is cited to establish the publication date of another citation or other special reason (as specified)
- *O* document referring to an oral disclosure, use, exhibition or other means
- *P* document published prior to the international filing date but later than the priority date claimed

- *T* later document published after the international filing date or priority date and not in conflict with the application but cited to understand the principle or theory underlying the invention
- *X* document of particular relevance; the claimed invention cannot be considered novel or cannot be considered to involve an inventive step when the document is taken alone
- *Y* document of particular relevance; the claimed invention cannot be considered to involve an inventive step when the document is combined with one or more other such documents, such combination being obvious to a person skilled in the art.
- *&* document member of the same patent family

Date of the actual completion of the international search

26 May 1995

Date of mailing of the international search report

16.06.95

Name and mailing address of the ISA

European Patent Office, P.B. 5818 Patentlaan 2
 NL - 2280 HV Rijswijk
 Tel. (+ 31-70) 340-2040, Tx. 31 651 epo nl,
 Fax (+ 31-70) 340-3016

Authorized officer

Franks, N

INTERNATIONAL SEARCH REPORT

Information on patent family members

International Application No
PCT/US 94/10476

Patent document cited in search report	Publication date	Patent family member(s)	Publication date
US-A-4381697	03-05-83	US-A- 5147669	15-09-92
