

S. Day.

Sheet 1 of 2 Sheets.

Magazine Fire-arm.

No. 364.

Patented Aug. 31, 1837.

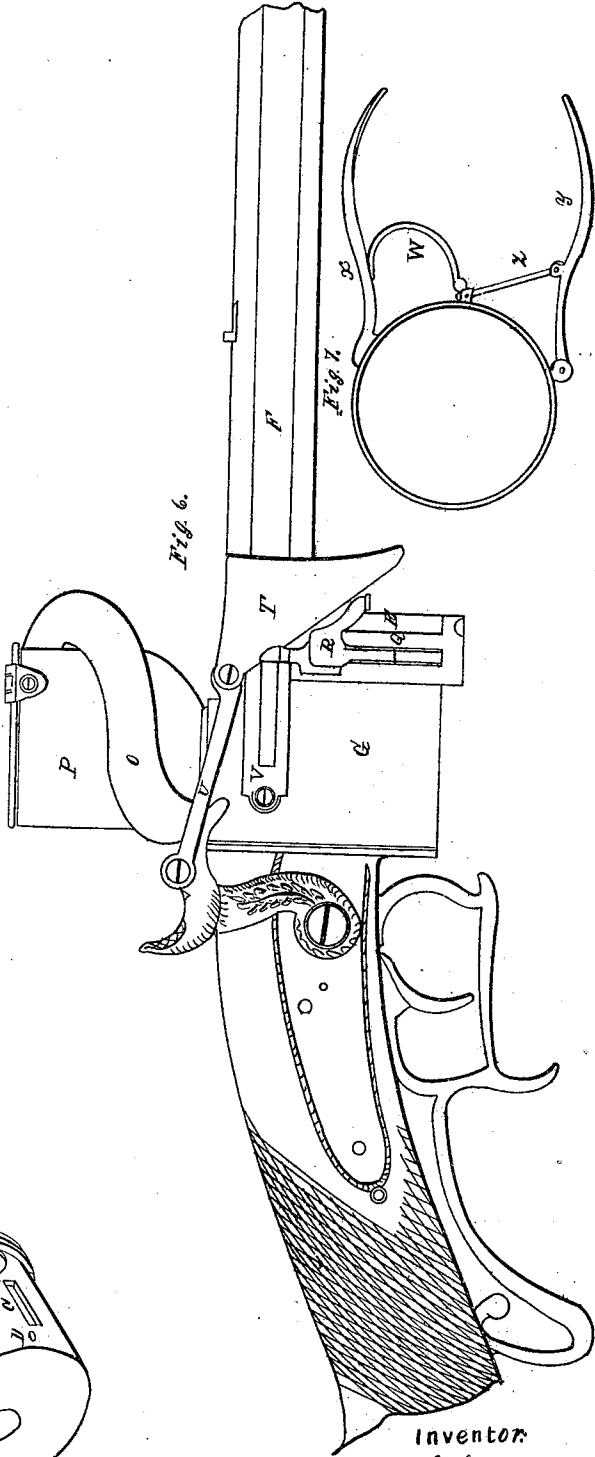
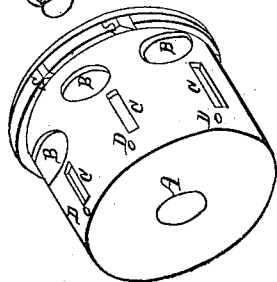
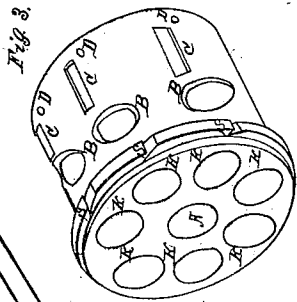
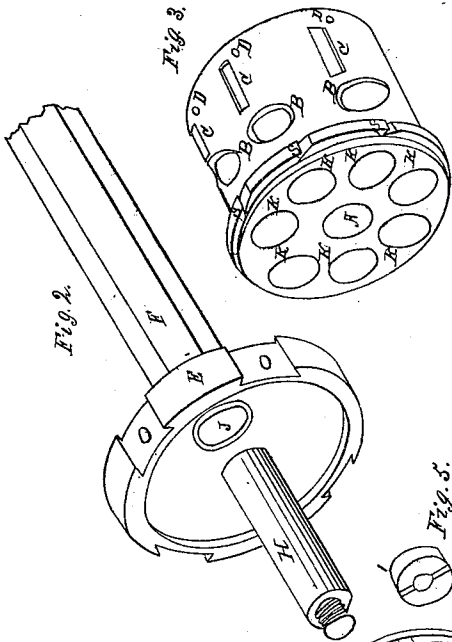
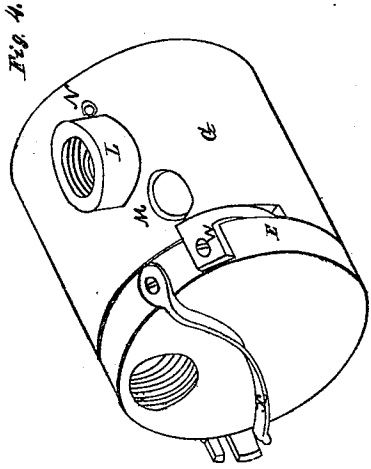

Witnesses:

Josh E. Clapp
Camm & Warren

Fig. 1.

Inventor:
Silas Day

S Day.

Magazine Fire-arm.

No 364.

Patented Aug. 31. 1837.

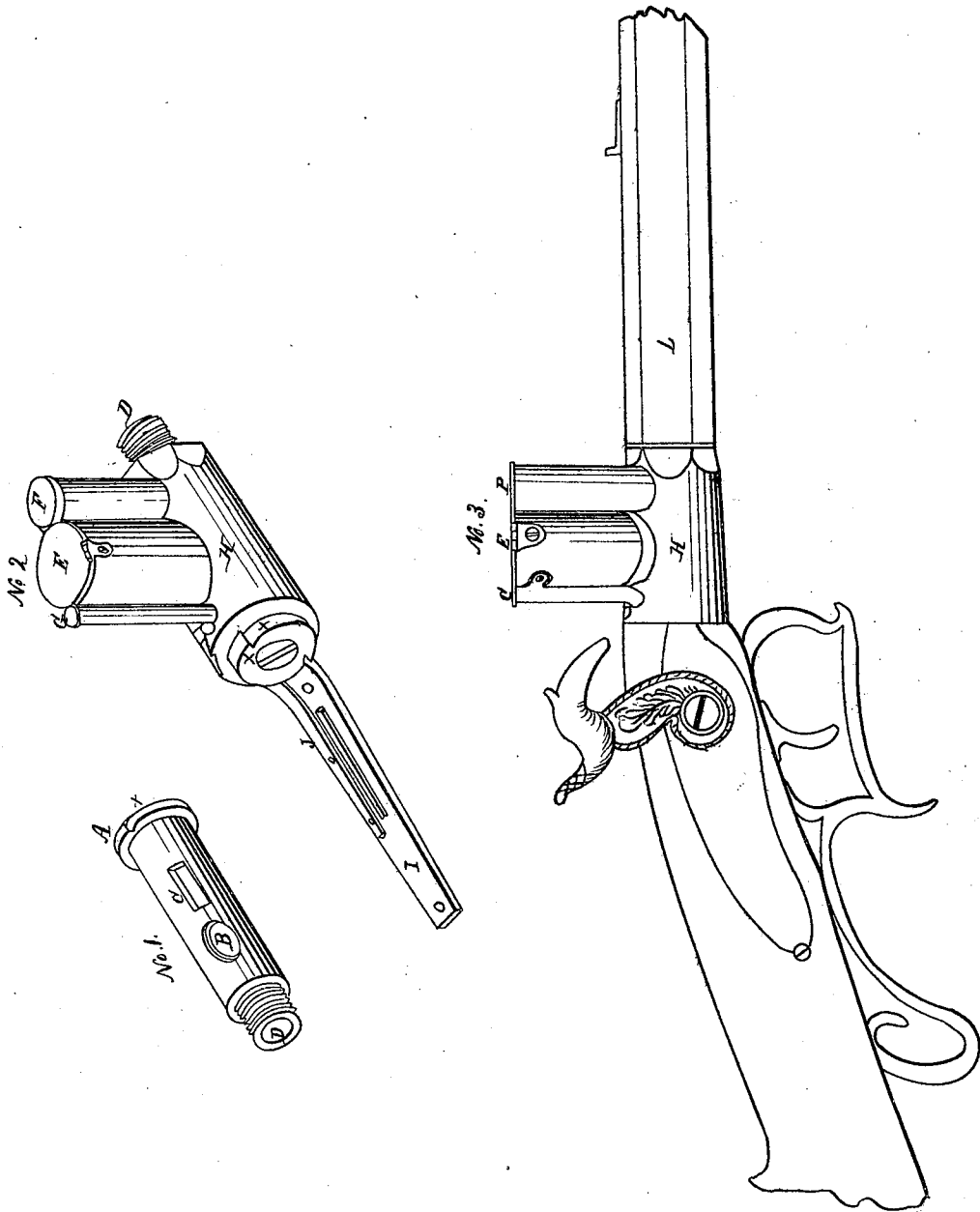

Witnesses:

Seth P. Clapp
Amos L. Warren

Inventor.

Seth Day

UNITED STATES PATENT OFFICE.

SILAS DAY, OF NEW YORK, N. Y.

IMPROVEMENT IN SELF LOADING AND PRIMING FIRE-ARMS.

Specification forming part of Letters Patent No. 364, dated August 31, 1837.

To all whom it may concern:

Be it known that I, SILAS DAY, of the city, county, and State of New York, have invented a new and useful Improvement in Fire-Arms, called the "Self Loading and Priming Rifle;" and I do hereby declare that the following is a full and exact description.

The nature of my invention consists in attaching to the stock, at the breech of the gun, a single or many chambered cylinder, which receives from a magazine placed above it the charges one at a time, as often as the gun is cocked. The many-chambered cylinder contains only two charges at any one time. The single cylinder is loaded by simply turning the barrel half round twice.

To enable gunsmiths and others skilled in similar business to make and use this rifle, I herein more fully describe its construction.

The cap, (see the annexed drawings, Plate I, No. 2:) This is a piece of solid metal, generally cast-steel, turned to its shape. Its form is that of a circular disk, E, about two inches diameter, with a spindle, H, on one side at the center, about two inches long and three-eighths of an inch thick. On one side of the disk a recess is turned out one-eighth of an inch deep. A hole, J, is made in the disk on one side of the center, in which is screwed the barrel F. This spindle is the axis upon which turns the many-chambered cylinder.

The many-chambered cylinder, (Plate I, annexed drawings, Nos. 1 and 3:) This is turned out of a solid piece of metal one inch and three-fourths long and an inch and a half diameter. A hole through the center A admits it upon the spindle of the cap. An enlargement or collar at the outer end has as many notches S as there are chambers. The chambers K, No. 3, in any convenient number, are drilled out equidistant around the center, leaving sufficient substance at the bottom, in which is drilled a smaller hole to receive the priming from the touch-hole D. Upon the outside are holes B C D connecting with each chamber—one round hole, B, for the ball, which, when the rifle loads, falls in first; a long hole, C, in the shape of a parallelogram, to admit the powder, and a small hole, D, for the percussion-priming.

The outside cylinder, (see plate I, annexed drawings, No. 4:) This serves to contain the

many-chambered cylinder, which is first turned and then fitted into it by grinding. It is made stout to sustain the explosive force of the powder. The many-chambered cylinder is put into this, and secured there by dovetails or fins with screws. These cylinders are held upon the spindle of the cap by a nut which is sunk in the end of the outside cylinder. M, the ball-hole; N, for the priming.

The magazine, (Plate I, No. 6:) This is cup-shaped and attached to the outside cylinder at L. It is for containing the powder, which passes down through a hole to C in Nos. 1 and 3. Around it is a spiral pipe, O, for the balls. A small tube for the priming passes down through the cup-shaped magazine P to the holes N, Nos. 1 and 3. The spiral pipe is attached to the outside cylinder at top. The magazine is covered with a lid.

The apparatus for loading, (No. 6, Plate I:) This is attached to the outside cylinder. When the gun is cocked by pulling back the hammer, a cam, T, with a dovetail-notch, sliding in the groove V, connected with it by a rod, U, moves a ratchet, R, which catches into the notches S of the cylinder Nos. 1 and 3. The ratchet is then moved back to its original position by a spring, K, No 4, or by the finger. Every time the gun is cocked the many-chambered cylinder is moved one notch and receives one charge. The gun is discharged by the hammer striking into the hole N, No. 4, which, when the gun is loaded, by pulling back the hammer, receives percussion-powder.

Instead of a cam, as described, for turning and loading the cylinder, a pair of handles are attached (see No. 7) to the outside cylinder beneath, at the front end. One of them, X, is stationary. The other, Y, is hinged. The connecting-rod Z is hinged at one end upon the handle Y, and at the other upon the ratchet. The spring W serves to push back the ratchet. To load by this process, these handles are pressed together with the left hand, while the gun is cocked with the right.

When this rifle is to have but one chamber, the cylinder is a single tube bored out a little larger than the barrel. (See annexed Plate II.)

No. 1 is the inner cylinder or chamber, called the "revolving breech." A, No. 1, is the collar, with a notch upon each side, in which the spring J, No. 2, catches. Upon one side

are two holes, B, to receive the ball C for the powder, and on the opposite side is the touch-hole to receive the priming. On one end is a screw, which fastens it to the barrel.

No. 2 shows the outside cylinder with the magazine C E F upon it. Into this the revolving breech is fitted, being turned of a slightly conical form and ground in from the back end. Upon the top of the outside cylinder is a magazine, as before described, except that the pipe for the ball is vertical instead of being spiral. This apparatus is attached to the stock by a strap, I, No. 2, the top being fastened by another smaller. Upon the strap I is a spring, J, which catches into the notch K of the collar.

To load this it is only necessary to turn the barrel. The spring J catches it when turned half round, and the ball and powder fall into the chamber. It is then turned the other half round, and during the turning the percussion-priming falls into the touch-hole. It is discharged in the ordinary way.

What I claim as my invention, and desire to secure by Letters Patent, is as follows:

1. The method above described of turning the many-chambered cylinder within another by means of a ratchet and notches, either with a cam or handles.

2. I claim the method of attaching one single chamber or revolving breech to the gun, by means of which it is only necessary to turn the barrel to load it and protect the magazine from the danger of explosion.

3. I claim the spiral tube to contain the balls.

4. I claim the method of putting one chambered cylinder within an outside one for greater strength and safety.

SILAS DAY.

Witnesses:

SETH E. CLAPP,
OWEN G. WARREN.