

- [54] VAGINAL RADIUM APPLICATOR
- [76] Inventor: **Harrith M. Hasson**, 6942 N. Waukesha Ave., Chicago, Ill. 60646
- [22] Filed: **June 1, 1971**
- [21] Appl. No.: **148,823**
- [52] U.S. Cl. **128/1.2, 128/17, 128/345**
- [51] Int. Cl. **A61n 5/10**
- [58] Field of Search **128/1.1, 1.2, 7, 17, 345**

Primary Examiner—William E. Kamm
 Attorney, Agent, or Firm—George H. Gerstman

[57] **ABSTRACT**

A radium applicator for treating cancer of the uterus formed in the shape of a vaginal speculum. The speculum applicator comprises an upper colpostat housing having a pair of pivotable arms connected thereto and a lower retractor blade assembly. A radium-carrying ovoid is connected to each colpostat arm and a linkage is connected to each ovoid for pivoting each ovoid about an axis that is substantially perpendicular to the pivotal axis of its colpostat arm. Means are provided for connecting a radium-carrying tandem to the colpostat's saddle handle after the applicator has been inserted in the vagina.

- [56] **References Cited**
- UNITED STATES PATENTS**
- | | | | |
|-----------|---------|-------------|----------|
| 2,544,939 | 3/1951 | Ritala..... | 128/1.2 |
| 1,014,799 | 1/1912 | Arthur..... | 128/17 |
| 3,060,924 | 10/1962 | Rush..... | 128/1.2 |
| 2,844,144 | 7/1958 | Massen..... | 128/17 X |
| 2,516,261 | 7/1950 | Schutt..... | 128/1.2 |
- FOREIGN PATENTS OR APPLICATIONS**
- | | | | |
|---------|---------|---------------|---------|
| 699,329 | 11/1940 | Germany | 128/1.2 |
|---------|---------|---------------|---------|

8 Claims, 7 Drawing Figures

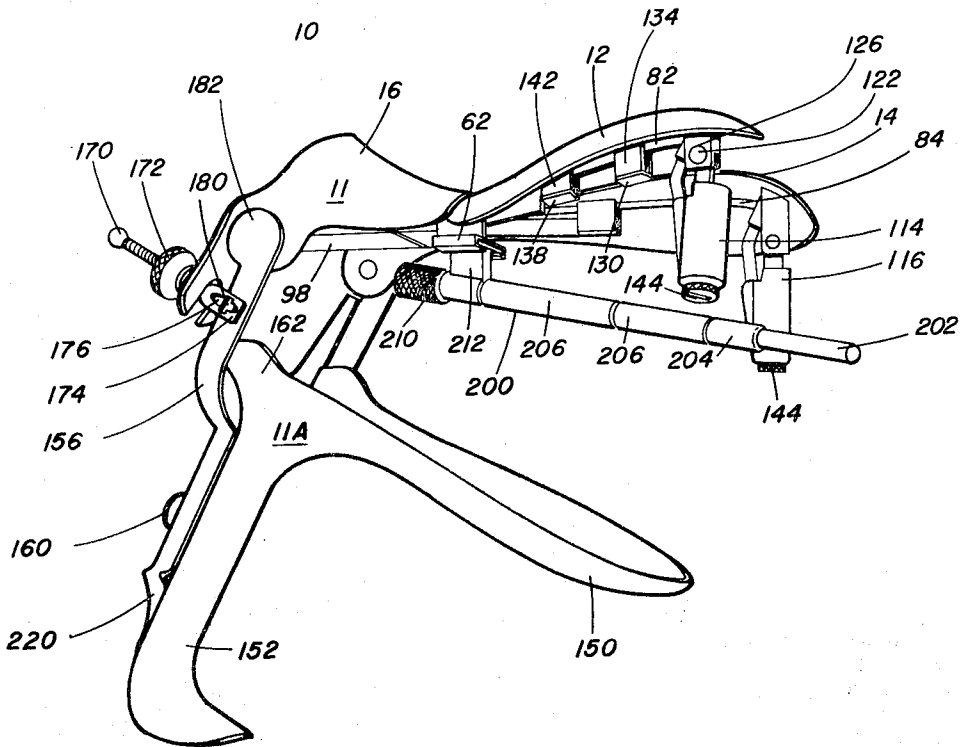

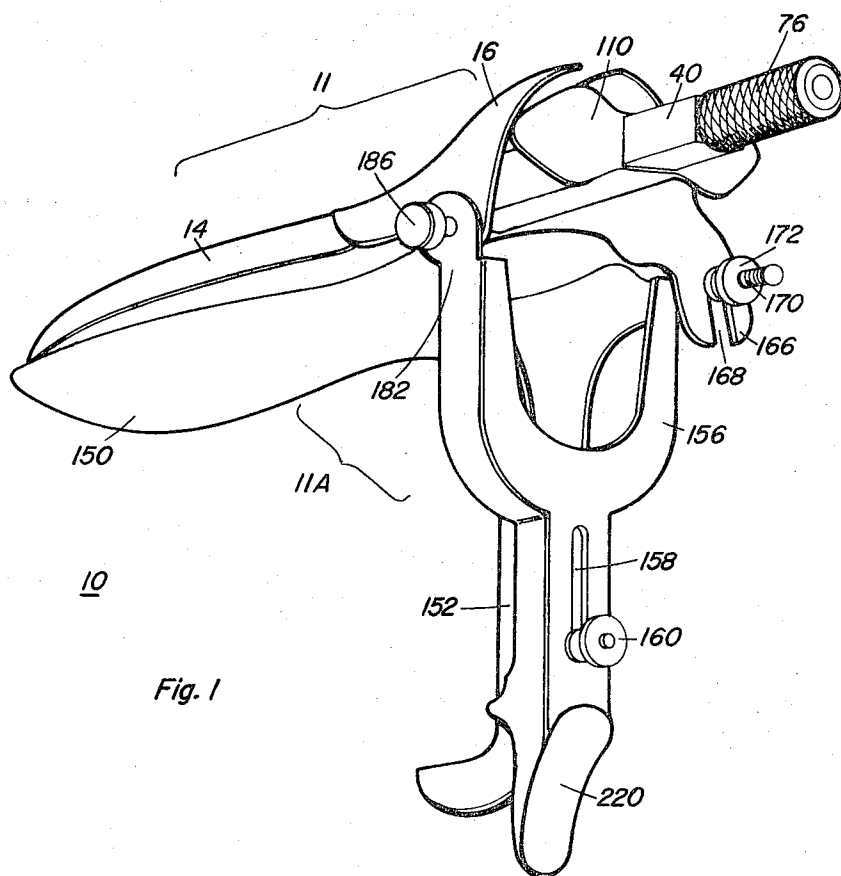

Fig. 1

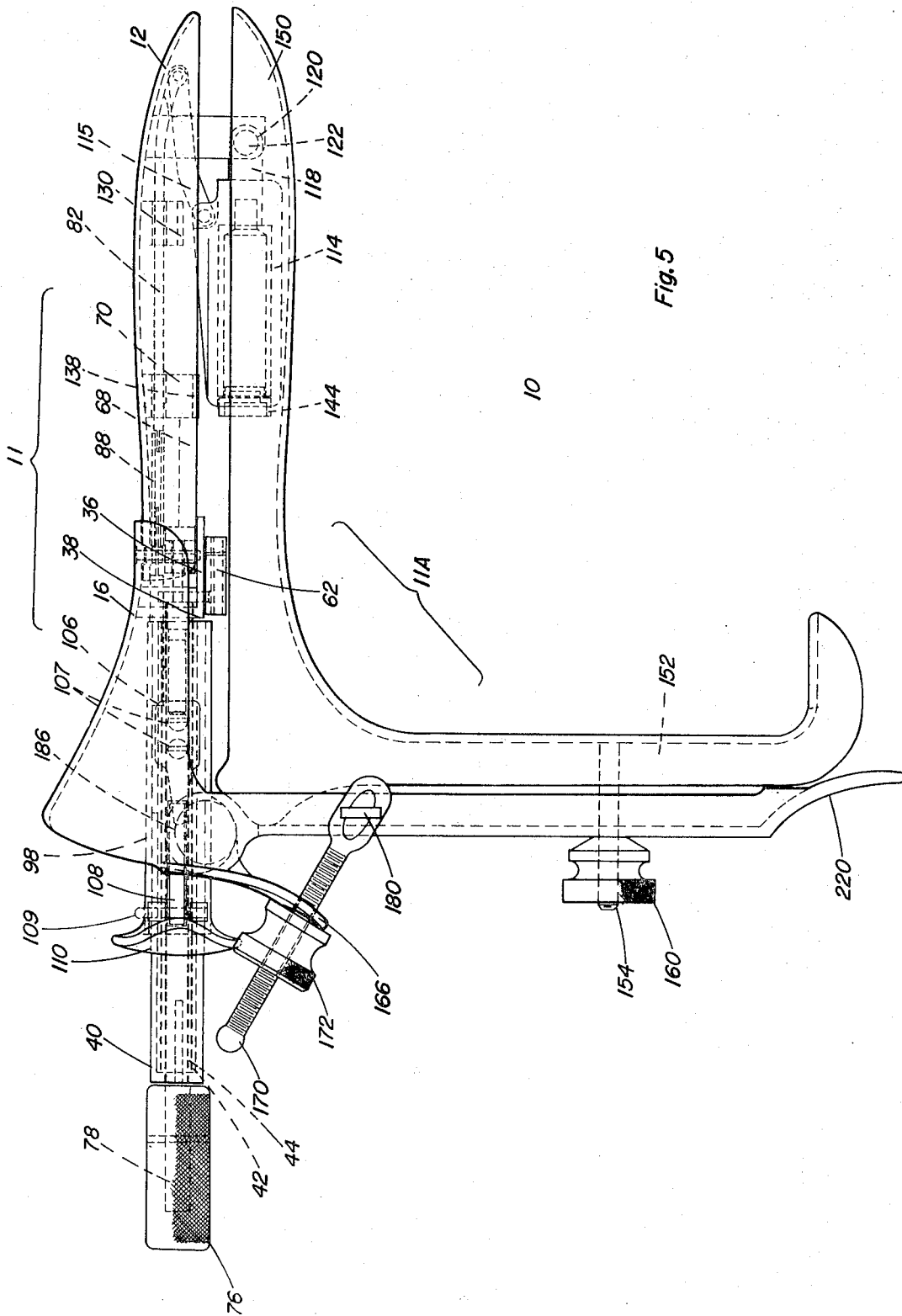

Fig. 5

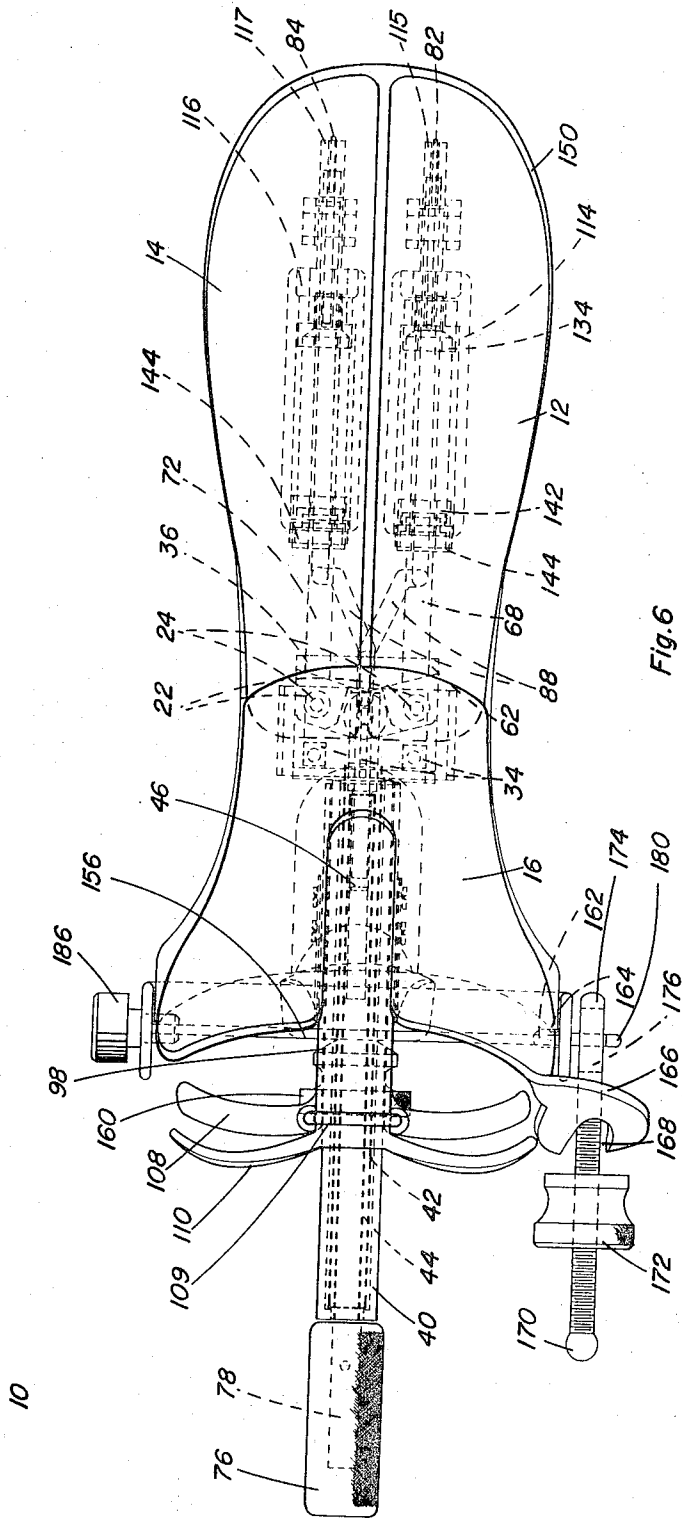

Fig. 6

10

VAGINAL RADIUM APPLICATOR

BACKGROUND OF THE INVENTION

This invention relates to a vaginal applicator for treating cancer of the uterus with radium therapy. As used herein, the term "radium" is also intended to cover any radioactive material useful in cancer treatment.

Cancer of the uterus is often treated by inserting into the vagina and uterus a radium-bearing applicator. Such applicators are well-known and are sold by Radium Chemical Company, Inc., 161 East 42nd Street, New York, N.Y. 10017.

Radium applicators typically comprise a pair of arms which carry at their ends ovoids which hold a radium source. Some applicators have provision for a central elongated rod, called a tandem, which also carries a radium source. One type of prior art applicator has adjustable ovoids with a stationary tandem which is inserted into the vagina simultaneously with the ovoids. Such simultaneous insertion limits the depth to which the ovoids can be inserted. In many such instances, the ovoids cannot be inserted as far as would be desirable and the placement may be inaccurate.

Another type of prior art applicator has stationary ovoids, and the tandem can be inserted subsequent to insertion of the ovoids. Although subsequent insertion of the tandem is generally preferable to simultaneous insertion, applicators with stationary ovoids have certain difficulties because of their symmetry and inflexibility. For example, it has been found that if the uterus is not symmetrical about the axis of the vagina, certain areas of the uterus will be closer to the radium sources than other areas. Hence a displaced uterus may occasion "hot spots" because of the location of a symmetrical, relatively inflexible applicator with respect to a uterus that is not symmetrical about the axis of the vagina, resulting in overtreating one side of the uterus and adjacent tissues and undertreating the opposite side.

In the present invention, an applicator is provided which has the structure and adjustability to enable it to be properly positioned with respect to a uterus that is normally not symmetrical about the axis of the vagina, as well as a symmetrical uterus. In this manner, the ovoids and tandem can be located properly with the radium being directed in a selected manner without resulting in undesirable "hot spots." Further, once inserted, the applicator of the present invention will remain in proper position in contrast to prior art applicators in which the ovoids can turn after insertion thereby permitting radiation to be directed improperly. Furthermore, any shifting or tilting in the application of the present invention will be readily apparent and can be easily corrected since the applicator, fashioned in the shape and form of a gynecological vaginal speculum, has its outermost end, the saddle handle, readily visible outside the vagina, indicating the axis of the device.

It is, therefore, a principal object of the present invention to provide a radium applicator which has a flexibility to allow it to be positioned properly and selectively with respect to non-symmetrical as well as symmetrical uteri.

It is also an object of the present invention to provide a radium applicator which permits adjustable ovoids to be first inserted into the vagina and permits an adjust-

able tandem subsequently to be inserted in the uterus.

Another object of the present invention is to provide a radium applicator which may aid in properly positioning the uterus with respect to the vagina in order to obtain proper radium therapy.

Other objects and advantages of the present invention will become apparent as the description of the present invention proceeds.

BRIEF DESCRIPTION OF THE INVENTION

In accordance with the present invention, there is provided a radium applicator shaped like a vaginal speculum which includes an upper colpostat housing having a pair of colpostat arms connected thereto and a lower retractor blade. An ovoid for carrying radium is connected to each colpostat arm and means are provided for pivoting each colpostat arm, whereby the distal ends of the arms can be moved apart from each other. A linkage is connected to each ovoid for pivoting each ovoid about an axis that is substantially perpendicular to the pivotal axis of its colpostat.

In the illustrative embodiment of the present invention, the housing has means connected thereto for receiving a radium-carrying tandem. The tandem includes an elongated rod-shaped member adapted for carrying radium and has means for connecting the tandem to the saddle of the colpostat after the applicator has been inserted into the vagina.

A more detailed explanation of the invention is provided in the following description and claims and is illustrated in the accompanying drawings.

BRIEF DESCRIPTION OF THE DRAWINGS

FIG. 1 is a perspective view of a radium applicator constructed in accordance with the principles of the present invention, with the applicator shown in its closed position and viewed from the left rear thereof;

FIG. 2 is a perspective view of a radium applicator constructed in accordance with the principles of the present invention, with the applicator shown in its open position and with a tandem connected thereto, viewed from the right front thereof;

FIG. 2A is an enlarged exploded view of the tandem, together with a side elevation thereof;

FIG. 3 is an exploded view of the applicator of FIG. 1;

FIG. 4 is a fragmentary perspective view, partially broken for clarity, of the colpostat drive mechanism of the applicator of FIG. 3;

FIG. 5 is a side elevational view of the applicator of FIG. 1; and

FIG. 6 is a top plan view of the applicator of FIG. 1.

DETAILED DESCRIPTION OF THE ILLUSTRATIVE EMBODIMENT

Referring to the figures, it is seen that radium applicator 10 comprises upper colpostat housing 11 and lower retractor blade assembly 11A. Referring to FIG. 3 in particular, it can be seen that the colpostat housing 11 includes a right colpostat arm 12, a left colpostat arm 14 and a saddle 16. Saddle 16 holds in place the inboard ends 18, 20 of colpostat arms 12, 14, respectively, by bolts 22 which extend through recesses 24 defined by saddle 16 and recesses 26 defined by the colpostat arms, and which bolts extend into recesses 28 of right colpostat drive brace 30, left colpostat drive brace 32 and finally into threaded recesses in plate 36.

Saddle 16 carries downwardly extending seat members 34 which seat on plate 36 of saddle brace 38. Saddle brace 38 is fastened to a housing 40 having a square cross-sectional configuration and carrying therewithin an outer locating tube 42 and an inner screw tube 44 for threaded engagement with the threads 46 of extender pin screw 48. Extender pin screw 48 carries vertically extending pins 50, 52 which, respectively, engage the walls defining recess 54 of left colpostat drive brace 32 and recess 56 of right colpostat drive brace 30.

Upper surface 60 of tandem shoe 62 engages the undersurface of plate 36. Saddle 16, saddle brace 38 and tandem shoe 62 are connected together by means of screws 64 which enter recesses 66 defined by upper surface 70, corresponding recesses (not shown) defined by plate 36 and corresponding recesses (not shown) defined by saddle members 34.

Right colpostat drive brace 30 includes a forwardly extending arm 68 having a block 70 fastened to its distal end and left colpostat drive brace 32 has an extending arm 72 having a block 74 connected to its distal end. A removable separator thumb wheel 76 and shaft locator 78 is inserted into inner screw tube 44 in housing 40 so that shaft locator 78 engages inner screw tube 44 to provide rotation of inner screw tube 44 when thumb wheel 76 is turned. Such rotation will cause extender pin screw 46 to move longitudinally with respect to housing 40, thereby pivoting right and left colpostat drive braces 30 and 32. Drive braces 30 and 32 are fastened to the colpostat arms by blocks 70, 74 which are attached directly to the undersurfaces of the respective colpostat arms.

The ovoid assembly comprises main extender shafts 82, 84 which are connected at 86 to an intermediate linkage 88. Intermediate linkage 88 carries a pin 90 which slides within a slot 92 of center extender shaft 94. The center extender shaft 94 is fastened to the inside of handle housing 98 by means of pins which enter recesses 100 of the center extender shaft and recesses 102 of the handle housing. Handle housing 98 slides on the front portion 104 of housing 40, with center extender shaft 94 sliding within guide slot 96 of housing 40. A pair of springs 106 are located on the outside of handle housing 98 and connected thereto by two screws 107. Springs 106 provide pressure on cam handles 108 therefore forcing cam handles 108 into frictional engagement with housing 40 when the cam handles 108 are released. Cam handles 108 are connected to handle housing 98 by means of U-shaped member 109, the sides of which extend into apertures 109' defined by cam handles 108. Springs 106 force cam handles 108 inwardly. The cam handles 108 cooperate with backplate 110 to enable the handle housing 98 to be precisely moved along housing 40. It can be seen that movement of housing 98 with respect to housing 40, after a predetermined distance, will force extender shafts 82 and 84 to move longitudinally.

Ovoids 114 and 116 are carried by main extender shafts 82 and 84, in pivotal relationship therewith, through links 115, 117 which are pivotally connected to the main extender shafts. The ovoids are identical in construction, with each having a pivot extension 118 defining a recess 120 for carrying a pivot pin 122, which pivot pin is surrounded by a retracting spring 124 which biases the ovoids upwardly as in the position shown in FIGS. 3, 5 and 6. Pivot pins 122 extend into

recesses defined by ovoid holders 126 (see FIGS. 2 and 5) and the forward section of the main extender shafts 82 and 84 is supported by shaft retainers 130 and 132, respectively, which are fastened to downwardly extending members 134 which are fastened to the underside of the respective colpostat arms (see FIGS. 2 and 5). The rear section of extender shafts 82 and 84 is maintained in place by means of retainers 138 and 140 which are fastened to downwardly extending members 142 which are fastened to the underside of the respective colpostat arms as shown in FIGS. 2 and 5.

Each of the ovoids is substantially hollow and can be loaded with the desired amount of radium. To this end, a threaded closure member 144 with a formed and connected lead insert is provided and is utilized as a radioactive shield. The upper part of the ovoid is also filled with lead to act as a shield (not shown) so that both the upper and lower ends of the ovoid contain a built-in lead shield to screen the adjacent structures, namely the bladder and rectum, from radiation.

Applicator 10 further includes a lower retractor blade assembly 11A. This consists of a lower blade 150 having a downwardly extending portion 152 which carries a retaining bolt 154. A handle 156 is provided which defines a slot 158 through which retaining bolt 154 is protruding and is engaged by a retaining thumb wheel 160. It can be seen that lower blade 150 can move up and down with respect to handle 156 by loosening retaining thumb wheel 160 and allowing bolt 154 to ride within slot 158. Lower blade 150 has no direct connection to saddle 16.

Saddle 16 has a downwardly extending portion 166 defining a recess 168 the walls of which engage a spreader screw 170. Spreader screw 170 threadedly engages a spreader thumb wheel 172 and has a forward portion 174 which defines a recess 176, which recess is adapted to surround key 180 that is T-shaped to retain the spreader screw 170 in place. Handle 156 is generally Y-shaped and has a side portion 182 which defines a recess 184, the walls of which recess are engaged by retaining screw 186 that extends through recess 188 defined by side 190 of saddle 16 and enters recess 184 of side portion 182. Corresponding side 181 holds pin 162 which fits in recess 164 of saddle 16. A pivot is thereby provided between retaining screw 186 and pin 162 allowing saddle 16 to rotate around the line passing through those two points.

The tandem 200 includes an active section 204 which carries radium and is fastened to inactive section 206 by means of threads. Inactive section 206 is attached to tandem receptacle 212 by threaded rod 208 which is attached to handle 210. The active section 204 may have different lengths of its fore section 202. Inactive sections 206 are also available in different lengths. The tandem receptacle 212 may also have different lengths and angles. These variable dimensions are compensating factors to allow for different depths of the vagina and different positions of the cervix in the vaginal cavity.

A tandem receptacle 212 is fastened to tandem 200 and is shaped for insertion into tandem shoe 62. Tandem receptacle 212 carries a pair of retaining springs 214 which engage the underside of the top plate forming the tandem shoe 62 for retaining the receptacle 212 in position within shoe 62.

It can be seen that the outer configuration of applicator 10 is similar in many respects to the configuration

of the conventional speculum. In this manner, it will be relatively simple for the physician who has used a speculum to become acquainted with an applicator constructed in accordance with the present invention. The applicator in fact functions as a speculum, in the first step of application, to expose the vagina and cervix uteri and to position the radium in the ovoids and tandem properly.

OPERATION

Speculum colpostats are made in different sizes, such as small, medium and large, to accommodate differences in vaginal size and flexibility. In the operation of the device, retaining thumb wheel 160 is loosened allowing lower blade 150 to be brought to its uppermost position, and spreader thumb wheel 172 is loosened so that the distal ends of colpostat arms 12 and 14 are as close as possible to lower blade 150 as shown in FIG. 1. The speculum-colpostat is inserted into the vagina. The colpostat arms and lower blade are then spread apart with pivot movement about the axis of screw 186 and pin 162, by turning thumb wheel 172 clockwise, until the colpostat arms and lower blade are spread apart to a desired distance. The colpostat arms are then further moved apart from the lower blade by steadying and/or pushing handle 156 upward on thumb surface 220 and pushing downward on extending portion 152, after loosening retaining thumb wheel 160, so that bolt 154 will be in a selected position lower than uppermost portion of slot 158. When the colpostat arms and lower blade are apart and brought to a selected position providing adequate vaginal retraction and exposure, thumb wheel 160 is turned clockwise to tighten the handle 156 in place, against lower blade 150. Colpostat arms 12 and 14 are then pivoted about axis of screws 22, by turning separator thumb wheel 76 clockwise and in this manner, the distal ends of the colpostat arms will be apart from each other, as shown in FIG. 2. Separator thumb wheel 76 can then be withdrawn, to be inserted again after treatment has ended.

After the distal ends of the colpostat arms are spread apart a desired amount, stretching the vaginal fornix and thereby fixing the colpostat in the vagina, ovoids 114 and 116 are lowered into position by grasping cams 108 and pulling backward until the cams come in contact with back plate 110, then continuing to move the handle housing backward with respect to housing 40 until ovoids 114 and 116 are extended 90° and are perpendicular to colpostat arms 12 and 14. The lateral radium sources in the ovoids are thus placed in the stretched fornix in an optimum position close to the parametrium and "Point B" (an important point of reference well-known in the art of Radiotherapy).

With the applicator properly placed in the position of FIG. 2, a tenaculum or other cervix holding instrument may be placed securely on the anterior or posterior lip of the cervix. The uterus is then sounded and measured using the Wing Sound, invented by Dr. Harrith M. Haddon, which determines the individual lengths of the endometrial cavity and cervical canal. The length from the tandem shoe 62 to the cervix can be measured also. The proper length and angle for tandem receptacle 212 and the proper length and number of inactive sections 206 and length of active section 204 can thus be determined.

The tandem 200 can be assembled with handle 210 and rear threaded section 208. After proper assembly,

tandem 200 can be introduced into the uterus and locked into tandem shoe 62 and the cervix can still be viewed through the opening defined by saddle 16 and handle 156 as in a simple speculum. The tandem inserted, as described, tends to force the uterus to take a central position between the two ovoids. This will happen if the uterus is displaced away from the midline but is not firmly fixed in the displaced position. However, if the uterus is fixed by disease or otherwise so that the tandem cannot be centrally inserted in relation to the ovoids, then the tandem should be inserted at a later date, in a separate treatment or sitting, to minimize radiation hazard to pelvic tissues from over-exposure.

Once the colpostat arms are spread apart, the ovoids lowered and the tandem inserted in its proper position, the vagina is packed with wet gauze or other material to help keep the applicator in proper place and further separate the rectum from the radium sources. Handle 156 is then removed. The lower blade assembly 11A, including lower blade 150 and handle 156, can then be removed. First, thumb wheel 160 is loosened and removed. Then lower blade 150 is withdrawn by manipulating its downward extension 152. Then thumb wheel 172 is loosened and spreader screw 170 is removed withdrawing retaining screw 186 and releasing pin 162 extending inwardly from side 181 of handle 156 from its associated recess 164 of saddle 16 by pulling on saddle 16. Handle 156 is thus disconnected from saddle 16 and removed.

After the applicator minus lower blade assembly 11A has been in position in the vagina for a specified amount of time, the colpostat 11 can be easily removed. The vaginal pack is removed. Cam handles 108 are released allowing the ovoids to retract into a position parallel to the colpostat arms. Separator thumb wheel 76 is reinserted into separator tube (inner screw tube 44) and is turned counterclockwise to bring the colpostat arms 12 and 14 close together. The colpostat housing 11 with attached tandem is then withdrawn from the vagina by simply pulling on saddle 16.

SUMMARY OF OPERATION

The applicator is first inserted and used as a speculum to provide vaginal retraction and exposure. The colpostat arms are then made to spread apart a desired degree and the ovoids are lowered to occupy a proper lateral position in the vaginal fornix. Uterine and vaginal measurements are determined. A fittingly corresponding preassembled tandem is then inserted into the uterus and is locked into the colpostat's tandem shoe. The vagina is then packed with wet gauze or other means to stabilize the applicator and to ensure its fixation and proper orientation. Any shifting or tilting in the applicator is noted by observing the position of the colpostat's saddle, visible outside the vagina, and is corrected.

The lower part of the applicator or lower blade assembly is then rapidly disassembled and is removed. The previously fixed upper part of the applicator or colpostat remains in its proper place.

When the application is completed, the vaginal packing is removed, the ovoids are folded under the colpostat arms and the colpostat arms are brought close together. The folded colpostat with attached tandem drops in the vagina and is easily removed by pulling on

the saddle handle which remains visibly protruding outside the vagina throughout the application.

It can be seen that a radium applicator has been provided which permits simple vaginal insertion with adequate retraction and exposure, permits the colpostat arms to be adjustably spread to a position that is desirable for the particular uterus with which it is being used and permits the ovoids to be positioned in a desired location with respect to the uterus and surrounding pelvic tissues and with respect to the tandem which is subsequently inserted. The present invention provides a radium applicator which has substantially universal adjustability, is easy to insert and remove, and the operation of which can be rapidly learned by physicians who have used a conventional speculum.

Although an illustrative embodiment of the invention has been shown and described, it is to be understood that various modifications and substitutions may be made by those skilled in the art without departing from the novel spirit and scope of the present invention.

What is claimed is:

1. A radium applicator which comprises: an upper colpostat housing, said colpostat housing including a saddle and a pair of colpostat arms; means for connecting said colpostat arms to said saddle; an ovoid for carrying radium located adjacent to the distal end of each colpostat arm; means for pivotally connecting each said ovoid adjacent to the distal end of each said colpostat arm; means connected to said housing for pivoting each colpostat arm whereby the distal ends of the colpostat arms can be moved apart from each other, and a linkage connected to each ovoid for pivoting each ovoid about an axis that is substantially perpendicular to its colpostat arm pivot axis.

2. A radium applicator as described in claim 1, including a lower blade and means connecting said lower blade to said saddle; and said colpostat housing being positioned over said lower blade, to form a speculum-like instrument thereby providing proper vaginal exposure and retraction.

3. A radium applicator as described in claim 2, in which said saddle is of a length that is effective to permit it to remain visible outside the vagina, thereby indicating the position and direction of the colpostat and thereby being used to aid in removal of the colpostat housing at the end of the application.

4. A radium applicator as described in claim 2, wherein said lower blade has a downwardly extending

portion at one end thereof adapted for contact by the hand of the operator and a handle adjustably connected to said downwardly extending portion, means connecting said handle to said housing, said handle being operable to aid in effecting relative movement between said lower blade and said colpostat arms, and means for adjustably connecting said handle and said downwardly extending portion and for retaining said handle and said downwardly extending portion in a selected location.

5. A radium applicator as described in claim 2, including means for enabling rapid disconnection of said lower blade assembly from said upper colpostat housing.

6. A radium applicator as described in claim 1, said colpostat housing having means connected thereto for receiving a radium-carrying tandem, and a tandem comprising an elongated rod-shaped member adapted for carrying radium and having means for connecting said tandem to said tandem receiving means after the applicator has been inserted.

7. A radium applicator as described in claim 6, in which said tandem comprises several connected parts to allow adjustments in length, angle and height of the tandem.

8. A radium applicator which comprises: an upper colpostat housing, said colpostat housing including a saddle and a pair of colpostat arms; means for connecting said colpostat arms to said saddle; a first shaft connected to one of said arms; a first radium-carrying ovoid; a second shaft connected to the other of said arms; a second radium-carrying ovoid; means for movably positioning said first and second ovoids on said first and second shafts, respectively, with each ovoid being adapted for positioning at the distal end of one of said colpostat arms and at a location under said arms; means connected to said housing for pivoting each colpostat arm whereby the distal ends of the colpostat arms can be moved apart from each other; a lower blade; means connecting said lower blade to said saddle, said colpostat housing being positioned over said lower blade to form a speculum-like instrument; said saddle being of a length that is effective to permit it to remain visible outside the vagina, thereby indicating the position and direction of the colpostat and thereby being used to aid in the removal of the colpostat housing at the end of the application.

* * * * *

50

55

60

65