



(12) **DEMANDE DE BREVET CANADIEN
CANADIAN PATENT APPLICATION**

(13) **A1**

(86) Date de dépôt PCT/PCT Filing Date: 2020/03/11
 (87) Date publication PCT/PCT Publication Date: 2020/09/17
 (85) Entrée phase nationale/National Entry: 2021/08/17
 (86) N° demande PCT/PCT Application No.: US 2020/022128
 (87) N° publication PCT/PCT Publication No.: 2020/185916
 (30) Priorités/Priorities: 2019/03/14 (US62/818,214);
 2019/12/23 (US62/952,752); 2020/02/06 (US62/971,072)

(51) Cl.Int./Int.Cl. *G01F 22/00* (2006.01),
B65D 81/00 (2006.01), *F26B 5/06* (2006.01),
A01N 1/02 (2006.01)
 (71) Demandeur/Applicant:
 TERUMO BCT BIOTECHNOLOGIES, LLC, US
 (72) Inventeurs/Inventors:
 JOHNSON, NATHANIEL T., US;
 SUMMIT, RYLAN A., US;
 BRIDGES, DENNIS A., US;
 HLAVINKA, DENNIS J., US;
 PARAKININKAS, KESTAS P., US;
 WEIMER, KIRK L., US;
 ...

(74) Agent: ROBIC

(54) Titre : AGENCEMENT DE REMPLISSAGE DE CONTENANT DE LYOPHILISATION, SYSTEME ET PROCEDE D'UTILISATION

(54) Title: LYOPHILIZATION CONTAINER FILL FIXTURE, SYSTEM AND METHOD OF USE

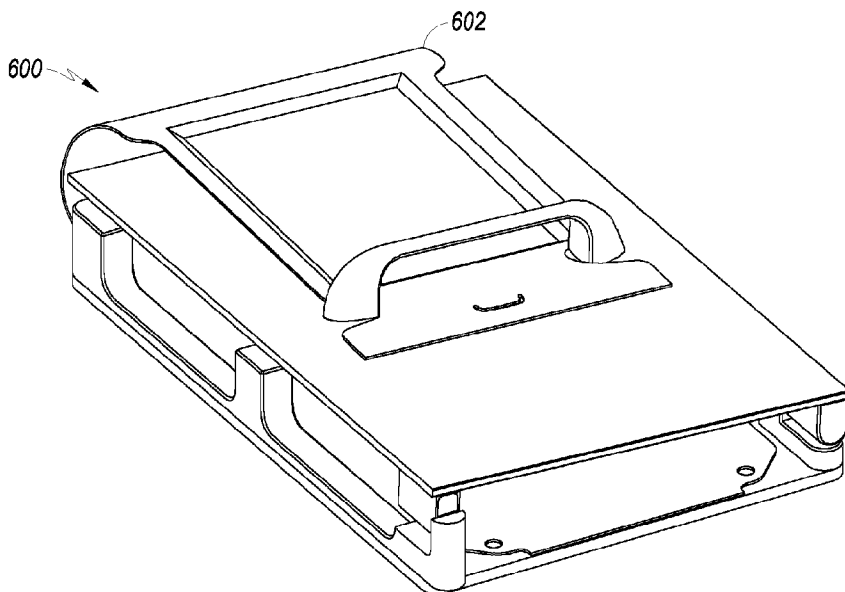

FIG. 6

(57) Abrégé/Abstract:

Provided is a gas fill fixture for use in lyophilization, a related system and method. The gas fill fixture includes a chassis, fill indicator and a lid, such that the chassis and lid together form a cavity for receiving a flexible lyophilization container. The system includes a lyophilization container, a lyophilizer and a gas fill fixture incorporating a chassis, a fill indicator and a lid. The method includes process steps for using the system to lyophilize a fluid.

(72) **Inventeurs(suite)/Inventors(continued):** GLOVER, MICHAEL LAWRENCE, US; NGUYEN, ALEXANDER DU, US;
KWIAT, MARGARET V., US

(12) INTERNATIONAL APPLICATION PUBLISHED UNDER THE PATENT COOPERATION TREATY (PCT)

(19) World Intellectual Property
Organization
International Bureau



(10) International Publication Number
WO 2020/185916 A1

(43) International Publication Date
17 September 2020 (17.09.2020)

(51) International Patent Classification:

G01F 22/00 (2006.01) *F26B 5/06* (2006.01)
A01N 1/02 (2006.01)

(21) International Application Number:

PCT/US2020/022128

(22) International Filing Date:

11 March 2020 (11.03.2020)

(25) Filing Language:

English

(26) Publication Language:

English

(30) Priority Data:

62/818,214	14 March 2019 (14.03.2019)	US
62/952,752	23 December 2019 (23.12.2019)	US
62/971,072	06 February 2020 (06.02.2020)	US

(71) Applicant: **TERUMO BCT BIOTECHNOLOGIES, LLC** [US/US]; 1215 Quail Street, Lakewood, Colorado 80215 (US).

(72) Inventors: **JOHNSON, Nathaniel T.**; 439 Bexley Lane, Highlands Ranch, Colorado 80126 (US). **SUMMIT, Rylan**

A.; 4669 Quitman Street, Denver, Colorado 80212 (US). **BRIDGES, Dennis A.**; 5213 Arbutus Street, Arvada, Colorado 80002 (US). **HLAVINKA, Dennis J.**; 7365 N. Salvia Court, Arvada, Colorado 80007 (US). **PARAKININKAS, Kestas P.**; 8094 S. Kalispell Way, Englewood, Colorado 80112 (US). **WEIMER, Kirk L.**; 1491 N. Stellers Jay Avenue, Green Valley, Arizona 85614 (US). **GLOVER, Michael Lawrence**; 1965 S. Cape Way, Lakewood, Colorado 80227 (US). **NGUYEN, Alexander Du**; 1195 S. Fairfax Street, Denver, Colorado 80246 (US). **KWIAT, Margaret V.**; 3213 Elk View Drive, Evergreen, Colorado 80439 (US).

(74) Agent: **CADY, Ryan C.**; Terumo BCT, Inc. IP Law Department, 10811 W. Collins Avenue, Lakewood, Colorado 80215 (US).

(81) Designated States (*unless otherwise indicated, for every kind of national protection available*): AE, AG, AL, AM, AO, AT, AU, AZ, BA, BB, BG, BH, BN, BR, BW, BY, BZ, CA, CH, CL, CN, CO, CR, CU, CZ, DE, DJ, DK, DM, DO, DZ, EC, EE, EG, ES, FI, GB, GD, GE, GH, GM, GT, HN, HR, HU, ID, IL, IN, IR, IS, JO, JP, KE, KG, KH, KN, KP,

(54) Title: LYOPHILIZATION CONTAINER FILL FIXTURE, SYSTEM AND METHOD OF USE

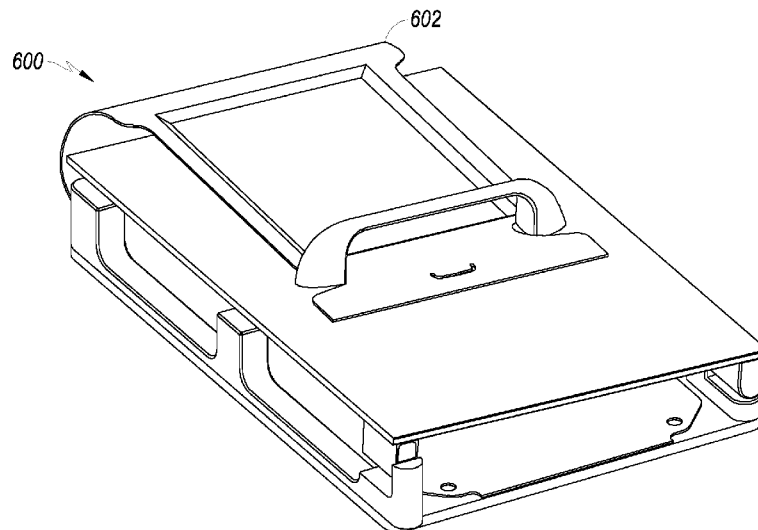

FIG. 6

(57) Abstract: Provided is a gas fill fixture for use in lyophilization, a related system and method. The gas fill fixture includes a chassis, fill indicator and a lid, such that the chassis and lid together form a cavity for receiving a flexible lyophilization container. The system includes a lyophilization container, a lyophilizer and a gas fill fixture incorporating a chassis, a fill indicator and a lid. The method includes process steps for using the system to lyophilize a fluid.

[Continued on next page]



WO 2020/185916 A1

WO 2020/185916 A1 

KR, KW, KZ, LA, LC, LK, LR, LS, LU, LY, MA, MD, ME, MG, MK, MN, MW, MX, MY, MZ, NA, NG, NI, NO, NZ, OM, PA, PE, PG, PH, PL, PT, QA, RO, RS, RU, RW, SA, SC, SD, SE, SG, SK, SL, ST, SV, SY, TH, TJ, TM, TN, TR, TT, TZ, UA, UG, US, UZ, VC, VN, WS, ZA, ZM, ZW.

- (84) Designated States** (*unless otherwise indicated, for every kind of regional protection available*): ARIPO (BW, GH, GM, KE, LR, LS, MW, MZ, NA, RW, SD, SL, ST, SZ, TZ, UG, ZM, ZW), Eurasian (AM, AZ, BY, KG, KZ, RU, TJ, TM), European (AL, AT, BE, BG, CH, CY, CZ, DE, DK, EE, ES, FI, FR, GB, GR, HR, HU, IE, IS, IT, LT, LU, LV, MC, MK, MT, NL, NO, PL, PT, RO, RS, SE, SI, SK, SM, TR), OAPI (BF, BJ, CF, CG, CI, CM, GA, GN, GQ, GW, KM, ML, MR, NE, SN, TD, TG).

Published:

- *with international search report (Art. 21(3))*
- *before the expiration of the time limit for amending the claims and to be republished in the event of receipt of amendments (Rule 48.2(h))*

LYOPHILIZATION CONTAINER FILL FIXTURE, SYSTEM AND METHOD OF USE

[0001] This application claims priority to U.S. Provisional Patent Application No. 62/818,214, entitled “Multi-part Lyophilization Container and Method of Use,” filed in the U.S. Patent and Trademark Office on March 14, 2019, U.S. Provisional Patent Application No. 62/952,752, entitled “Lyophilization Loading Tray Assembly and System,” filed in the U.S. Patent and Trademark Office on December 23, 2019 and Provisional Patent Application No. 62/971,072, entitled “Lyophilization Container Fill Fixture, System and Method of Use,” filed in the U.S. Patent and Trademark Office on February 6, 2020, each of which is incorporated by reference herein in its entirety.

[0002] The invention was made with government support under contract number H92222-16-C-0081 awarded by the United States Department of Defense. The government has certain rights in the invention.

Background

[0003] The present application relates to the lyophilization of a composite fluid, such as human or animal blood or blood plasma. In particular, the present application describes a gas fill fixture for preparing a flexible lyophilization container to be used in a lyophilization process, including a related system and method. The gas fill fixture is a rigid housing configured to house a flexible lyophilization container and to provide a gas fill indication to an operator. The system includes the gas fill fixture, a lyophilization container and a lyophilizer. The method relates to the inclusion of the gas fill fixture in a lyophilization process.

[0004] Various methods for lyophilizing a fluid are known. One example of such a method is described in U.S. Application Publication No. 2019/0106245 to Weimer et al., entitled “Lyophilization Container and Method of Using Same.” In the described method, a gas is added to a flexible lyophilization container which houses a fluid to be lyophilized. The gas is added to the flexible lyophilization container prior to the freezing step for the purpose of creating a vapor space above the ice cake to be formed. The inclusion of a vapor space above the formed ice cake facilitates vapor flow throughout sublimation and desorption.

[0005] At present, a simple and precise means for inputting a correct gas volume into the flexible lyophilization container does not exist. Current gas fill procedures are generally performed manually and are consequently considered to be cumbersome and imprecise. This imprecision, in turn, may result in

inconsistencies in batch lyophilization processes. Accordingly, the present application describes an improvement to current devices and techniques used to perform a gas fill step in the lyophilization of a biological fluid such as blood or a blood product.

[0006] Although specific embodiments of the present application are provided in view of the above-described considerations, the specific problems discussed herein should not be interpreted as limiting the applicability of the embodiments of this disclosure in any way.

Summary

[0007] This summary is provided to introduce aspects of some embodiments of the present application in a simplified form and is not intended to comprise an exhaustive list of all critical or essential elements of the claimed invention, nor is it intended to limit the scope of the claims.

[0008] In one aspect, embodiments provide for a gas fill fixture for use in lyophilization. The gas fill fixture includes a chassis, fill indicator and a lid. The chassis and lid together form a cavity configured to receive a flexible lyophilization container placed along its longitudinal axis therein.

[0009] In another aspect, embodiments provide for a system for lyophilizing a fluid. The system includes a lyophilization container, a lyophilizer and a gas fill fixture. The gas fill fixture includes a chassis, a fill indicator and a lid.

[0010] In yet another aspect, embodiments provide for a method of lyophilizing a fluid. The method includes inputting a liquid into a flexible lyophilization container, inputting a portion of the lyophilization container into a gas fill fixture, inputting a gas into the lyophilization container, determining an appropriate gas fill volume based on an indication from a fill indicator of the gas fill fixture, loading the lyophilization container into a lyophilizer and lyophilizing the fluid.

[0011] Further embodiments of the present application include additional methods and devices and systems for lyophilizing fluids. The fluid may be any suitable liquid, including human or animal plasma.

Brief Description of the Drawings

[0012] Non-limiting and non-exhaustive embodiments are described with reference to the following figures.

- [0013] FIG. 1 is an illustration of a flexible multi-part lyophilization container according to the related art;
- [0014] FIG. 2 is an illustration of a lyophilizer according to the related art;
- [0015] FIG. 3 is a plan view of a gas fill fixture according to an embodiment of the present application;
- [0016] FIGS. 4A to 4C are front views of a gas fill fixture according to an embodiment of the present application;
- [0017] FIG. 5 is a side view of a gas fill fixture according to an embodiment of the present application;
- [0018] FIG. 6 is perspective view of a gas fill fixture housing a flexible lyophilization container according to an embodiment of the present application;
- [0019] FIG. 7 is an illustration of a system for lyophilizing a fluid according to an embodiment of the present application; and
- [0020] FIG. 8 is a workflow schematic illustrating a lyophilization process according to an embodiment of the present application.

Detailed Description

[0021] The principles described in the present application may be further understood by reference to the following detailed description and the embodiments depicted in the accompanying drawings. Although specific features are shown and described below with respect to particular embodiments, the present application is not limited to the specific features or embodiments provided. Moreover, embodiments below may be described in association with the lyophilization of biological fluids, such as human or animal blood or blood components; however, such descriptions are merely illustrative. Those of skill in the art will appreciate that embodiments of this disclosure may be used in connection with the determining of a correct gas fill volume in many contexts.

[0022] Embodiments of the present application principally refer to a stand-alone fixture that is utilized in the preparation of a fluid to be lyophilized. More particularly, a gas fill fixture is described which allows for the placement of a flexible lyophilization container therein, and which provides an indication to an operator when a proper gas fill volume in the flexible container has been achieved.

[0023] Any suitable fluid may be prepared for lyophilization and lyophilized using the devices and techniques described in this disclosure, including a biological fluid such as human or animal blood or a blood product, such as blood plasma.

[0024] Various advantages of the enumerated embodiments are noted throughout this disclosure.

[0025] FIG. 1 is an illustration of a flexible multi-part lyophilization container according to the related art.

[0026] Referring to FIG. 1, the lyophilization container 100 includes a non-breathable section 102; including a port region 104; a breathable section 106, including a breathable membrane 108; and an occlusion zone 110.

[0027] In operation, lyophilization container 100 exchanges fluids via ports positioned in the port region 104 of non-breathable section 102. Fluid exchanges occur during the initial filling of the container with liquid plasma and during the post-lyophilization filling of the container with sterile water for reconstitution and transfusion into a patient. Non-breathable section 102 and breathable section 106 are isolated from one another by a peelable seal or by a creation of an occlusion of the container in the occlusion zone 110 encompassing the transition between the non-breathable section 102 and breathable section 106. In this respect, the occlusion zone (i.e., the position of the peelable seal and/or the occlusion) 110 defines the boundary between non-breathable section 102 and breathable section 106.

[0028] FIG. 2 is an illustration of a lyophilizer according to the related art.

[0029] Referring to FIG. 2, the lyophilizer 200 comprises timing and temperature controls 202; and a hydraulic shelf system 204.

[0030] The lyophilizer shown in FIG. 2 is generic illustration of a conventional lyophilizer suitable for use in conjunction with embodiments of the present application. Typical components of suitable conventional lyophilizers include timing and temperature controls, a refrigeration system, a vacuum system, a condenser and a chamber including a hydraulic shelf system capable of lyophilization and stoppering.

[0031] FIG. 3 is a plan view of a gas fill fixture according to an embodiment of the present application.

[0032] Referring to FIG. 3, gas fill fixture 300 comprises chassis 302, including platform 304, side wall 306 and hinges 308; lid 310; fill indicator 312 and handle 314.

[0033] Chassis 302 comprises platform 304, side wall 306 and hinges 308. Lid 310 is attached to chassis 302 via hinges 308. Fill indicator 312 and handle 314 are respectively attached to the bottom side and to the top side of lid 310.

[0034] The length and width of chassis 302 are respectively denoted as “L” and “W”. In the embodiment shown in FIG. 3, chassis 302 length is approximately 26cm and chassis 302 width is approximately 17cm. As shown, lid 310 length, denoted as “L_L,” is essentially coincident to the length of the chassis 302. Lid 310 width, denoted as “W_L,” is likewise essentially coincident to width of the chassis 302.

[0035] In embodiments, neither the size and shape of the chassis 302 or the lid 310, nor their relationship to one another, are limited. For example, chassis 302 length may be between 15cm and 50cm, such as between 25cm and 30cm, and chassis width may be between 10cm and 30cm, such as between 15cm and 20cm. Similarly, lid 310 length may be between 15cm and 50cm, such as between 25cm and 30cm and lid 310 width may be between 10cm and 30cm, such as between 15 and 20cm.

[0036] In the embodiment shown in FIG. 3, platform 304, side wall 306 and hinges 308 comprise a blend of Polycarbonate (PC) and Acrylonitrile Butadiene Styrene (ABS). PC/ABS is preferable for its toughness and impact resistance. Platform 304 is a solid piece of PC/ABS, whereas side wall 306 and hinges 308 are injection molded and cored using conventional techniques to reduce mass. Lid 310 is a transparent thermoplastic (e.g., acrylic). Thermoplastic is preferable for its durability and low cost. Transparency allows an operator to visually inspect the lyophilization container throughout a gas fill process.

[0037] In the embodiment of FIG. 3, hinges 308 are a type of pivot hinge. Each hinge 308 comprises a top and a bottom hinge mount respectively attached to lid 310 and to platform 314. Each of the top and the bottom hinge 308 mount comprises a cup configured to house a portion of a dowel forming a pivotal connection therebetween. Alternative embodiments are not limited and may include a variety of conventional hinges, such as alternative pivot hinges, a metal butt hinge or Mortise hinge. Fill indicator 312 is a mechanical gauge configured to provide an operator with a means to visually determine a correct gas fill volume of an inputted lyophilization container. Handle 314 is plastic and resembles a conventional cabinet door pull or drawer pull.

[0038] A variety of alternative materials may be used in the individual components of the gas fill fixture 300. Any material selected should be resilient under repeated use conditions, including but not

limited to plastics, metals, and metal alloys. In a preferred embodiment, fixture components are attached to one another with conventional screws; however, fixture components may be attached or adhered to one another using any other conventional technique, hardware, adhesive or the like.

[0039] In various alternative embodiments, a bumper or similar implement may be positioned between the side wall 306 and the lid 310 to absorb the shock of lid 310 closures, thereby prolonging fixture 300 lifespan. Such bumper embodiments may comprise any of a variety of materials, including but not limited to a high-density synthetic rubber such as Ethylene Propylene Diene Monomer rubber (EPDM). Material selected for use in a bumper should be shock absorbent and durable.

[0040] FIGS. 4A to 4C are front views of a gas fill fixture according to an embodiment of the present application.

[0041] Referring to FIGS. 4A to 4C, gas fill fixture 400 comprises chassis 402, including platform 404, side wall 406 and hinge 408; lid 410; fill indicator 412, including first indication section 414 and second indication section 416; and handle 418.

[0042] FIG. 4A is an illustration of a fill fixture 400 in a closed state. FIG. 4B is an illustration of a fill fixture 400 indicating a proper fill condition. FIG. 4C is an illustration of a fill fixture 400 indicating an overfilled condition.

[0043] In the embodiments shown in FIGS. 4A to 4C, chassis 402 is constructed from platform 404, side wall 406 and hinges 408 which together support lid 410. The fixture cavity formed within the assembled components is configured to accept, along its longitudinal axis, a portion of a flexible lyophilization container to be filled with a gas.

[0044] As shown in FIG. 4A, chassis 402 width, denoted as “W” is approximately 17cm. Each of side wall 406 width and hinge width is approximately 1.5cm. In embodiments, however, neither of side wall 406 width nor hinge 408 width are limited and either may be between .5cm and 5cm, such as between 2cm and 4cm. As shown, platform 404 width is coincident with chassis width. In embodiments, however, platform 404 width is not limited and may be between 10cm and 30cm, such as between 15cm and 20cm. In yet further embodiments having a differently configured chassis, platform 404 width may not be coincident to chassis width.

[0045] Overall fixture 400 height denoted as “H” is approximately 3.5cm. In embodiments, however, fixture height is not limited and may be between 2cm and 8cm, such as between 3cm and 5cm. Overall

fixture height includes lid 410 thickness and platform 404 thickness. As shown, each of lid 410 thickness and platform 404 thickness is approximately 0.5cm. In embodiments, however, neither lid 410 thickness nor platform 404 thickness are limited, and either may be between 0.1cm and 1cm, such as between 0.3cm and 0.7cm. Side wall 406 height and hinge 408 height are each approximately 2.5cm. In embodiments, however, neither side wall 406 height nor hinge 408 height is limited and either may be between 1cm and 5cm, such as between 2cm and 3cm.

[0046] Internal cavity height, denoted as “ H_c ,” is approximately 2.5cm. In embodiments, internal cavity height is not limited and may be between 2cm and 6cm, such as between 3cm and 5cm. As shown in FIG. 4, internal cavity height is coincident to the side wall height and to hinge 408 height; however, in alternative embodiments comprising a differently configured chassis, internal cavity height may not be coincident to side wall 406 height or hinge 408 height. Internal cavity width, denoted as “ W_c ,” is approximately 14cm. In embodiments, however, internal cavity width is not limited and may be between 8cm and 20cm, such as between 12cm and 16cm. Internal cavity length, although not shown, is generally coincident to chassis length and, in embodiments, may vary accordingly. In embodiments, any of the fixture dimensions, including their relationship to one another, are not limited and may vary.

[0047] As described below and shown in FIGS. 4A to 4C, fill indicator 412 is a vertically oriented, linear indicator attached to the bottom side of lid 410. Fill indicator 412 may be considered a conventional go/no-go gauge including a first indication section 414 and second indication section 416; the first section indicating a proper fill condition and the second section indicating an overfilled condition. In alternative embodiments; however, the location and configuration of fill indicator 412 is not limited and may vary without departing from the scope of this application.

[0048] FIG. 4A illustrates fill fixture 400 in a closed position. That is, lid 410 is at rest on chassis 402, and the fill indicator 412 remains obstructed from view behind an end portion of sidewall 406. In this closed position, fill indicator 412 does not indicate any fill condition.

[0049] FIG. 4B is an illustration of a fill fixture 400 indicating a proper fill condition. That is, a flexible lyophilization container has been placed within the fixture cavity and filled with a gas. Consequently, lid 410 has been lifted, and a first indication section 414 of fill indicator 412 configured to indicate that the lyophilization container has been filled with a desired amount of gas has been exposed. In exemplary embodiments, the color green is used to indicate a proper fill condition. However, in alternative embodiments, the type of visual indicator used for the first indication section is not limited and may be any suitable visual indicator such as another color, a conspicuous texture, or the like.

[0050] FIG. 4C illustrates fill fixture 400 in an overfilled condition. That is, a flexible lyophilization container has been placed within the fixture cavity and overfilled with a gas. Consequently, lid 410 has been lifted beyond a proper fill condition, exposing a second indication section 416 of fill indicator 412 designed to indicate that the lyophilization container has been filled with an amount of gas in excess of a desired amount. In exemplary embodiments, the color red is used to indicate an overfilled condition. However, in alternative embodiments, the type of visual indicator used for the second indication section is not limited and any suitable visual indicator that is dissimilar to the indicator used for a proper fill condition may be used. For example, another color, a different texture, or the like may be used to indicate an overfilled condition.

[0051] In embodiments, chassis 402 may include components comprising dissimilar materials. For instance, platform 404 may comprise plastic whereas side wall 406 and hinges 408 may comprise a metal or vice versa. In further embodiments, platform 404 and side wall 406 may be formed as a single component. Various additional material choices and design combinations are within the scope of this application and can be readily envisioned by one of skill in the art.

[0052] As shown in FIGS. 4A to 4C, handle 418 resembles a conventional cabinet door pull or drawer pull. Handle 418 may be sized to allow an operator to manipulate lid 410 with a bare hand or with a gloved hand. Handle 418 is disposed at approximately the center of lid 410, perpendicular to the longitudinal axis of the fixture 400 cavity. In this configuration, it is possible to load a portion of a flexible lyophilization container into the fixture cavity along its longitudinal axis and to fold the remainder of the flexible container over the edge of the lid 410 in a manner allowing the remainder of the flexible container to be secured in the void space of the handle 418 (See FIG. 6). In such embodiments, specialized features such as cutouts, indentations or any other suitable features may be incorporated into the flexible container to cooperate with the handle 418 in securing the container. The ability to secure the entire flexible container to the fill fixture 400 in this manner may simplify the process of obtaining an accurate weight of the combined fixture and container before a fill procedure.

[0053] FIG. 5 is a side view of a gas fill fixture according to an embodiment of the present application.

[0054] Referring to FIG. 5, gas fill fixture 500 comprises side wall 502, including cutout portions 504; fill indicator 506; lid 508; and handle 510.

[0055] As shown, when the lid 508 is in the closed position, the fill indicator 506 rests adjacent to, and at a minimal distance from, a portion of side wall 502. Maintaining a minimal distance between the

fill indicator 506 and the side wall 502 portion allows only one fill indication section of the fill indicator 506 to be visible to an operator at a given fill condition, thereby reducing the potential for operator error. Notably, side wall 502 includes cutout portions 504 to reduce mass and to reduce cost.

[0056] In further embodiments, fill indicator 506 may be differently configured and may include various alternative or additional technologies. For example, fill indicator 506 may be incorporated into one or more fixture components, and may comprise one or more of a camera, a sensor, a light or any other conventional electrical or mechanical means of providing a visual indication or performing visual or electronic monitoring or inspection of the gas fill process. The particular type of camera, sensor or light is not limited. For instance, an included sensor may be selected from among any of optical sensors, inductive sensors or capacitive sensors.

[0057] FIG. 6 is perspective view of a gas fill fixture housing a flexible multi-part lyophilization container according to an embodiment of the present application.

[0058] Referring to FIG. 6, gas fill fixture 600 is shown accommodating a flexible, multipart lyophilization container 602.

[0059] As shown, a non-permeable portion of the lyophilization container 602 has been loaded into the fixture 600 cavity and filled with a gas. Accordingly, the lid is shown as having been lifted from the chassis, allowing the fill indicator to extend upward and indicate a proper fill condition. A portion of the lyophilization container 602 including a gas permeable membrane has been folded over the lid of the gas fill fixture 600 and secured in the void space of the handle. The securing of the lyophilization container 602 in the handle is achieved by a cooperation between lyophilization container 602 features and complementary features of the fixture handle.

[0060] The fill fixture 600 assists an operator in the creation of a desired vapor space in the lyophilization container 602 to reduce the amount of ice “sticking” to the container material during and after the freezing step of lyophilization. Material and design choices should take into consideration that the creation of a vapor space in the lyophilization container 602 may cause container pressure to reach between 0.3 Pound per square inch (Psi) and 1.0 Psi, such as .5 Psi (approximately 26 mmHG).

[0061] FIG. 7 is an illustration of a system for lyophilizing a fluid according to an embodiment of the present application.

[0062] Referring to FIG. 7, the system 700 includes a gas fill fixture 702; a lyophilization container 704; a lyophilization loading tray 706; and a lyophilizer 708.

[0063] System 700 may vary in embodiments. For example, system 700 may exclude the lyophilization loading tray 706 altogether. In other embodiments, system 700 may employ components that are differently configured than those shown. For instance, lyophilizer 708 may be used in conjunction with a freezer that is a separate system component. Similarly, an alternatively configured lyophilization container 704 may result in differently configured system components which is within the scope of this application and can be readily envisioned by one of skill in the art. In yet further embodiments, various positioning and securing features may be incorporated into system components to ensure the proper positioning and securing of the lyophilization container to each system component.

[0064] An exemplary workflow included below describes the manner in which embodiments of the gas fill fixture may be included in a lyophilization process.

[0065] FIG. 8 is workflow schematic illustrating a lyophilization process according to an embodiment of the present application.

[0066] Referring to FIG. 8, in step 802, a subject fluid (e.g., blood plasma) is inputted into a non-breathable section of a flexible lyophilization container. In step 804, the non-breathable section of the lyophilization container is loaded into a gas fill fixture. In step 806, a gas is inputted into the non-breathable section of the lyophilization container. In step 808, an appropriate gas fill volume is determined based on a proper fill indication from fill indicator of the gas fill fixture. In this step, the gas is preferably Nitrogen; however, an alternative gas may be introduced, such as air, another inert gas, or a pH regulating gas, e.g., CO₂. In step 810, the lyophilization container is optionally attached to a loading tray or other loading apparatus. In step 812, the lyophilization container is loaded into to a lyophilizer. In step 814, the liquid in the lyophilization container is frozen, creating a thin, uniformly thick structure of ice in the non-breathable section. In step 816, an occlusion is removed from the lyophilization container, allowing a pathway to exist between the non-breathable section of the lyophilization container and a breathable section of the lyophilization container. In this step, the removal of the occlusion may comprise, e.g., the opening of a peelable seal or the release of a mechanical clamp. In step 818, vacuum and heat energy are applied to accomplish sublimation and desorption, causing a phase change in the ice structure from the solid phase directly to the vapor phase. Vapor released from the ice structure flows through the lyophilization container cavity via the created pathway and escapes through the breathable section of the lyophilization container, leaving a lyophilized plasma cake in the non-breathable section. In step 820, the lyophilization container

is optionally backfilled with an inert gas to raise lyophilization container pressure to partial atmospheric pressure. In step 822, the lyophilization container is occluded, dividing the non-breathable section from the breathable section in order to prevent contamination of the lyophilizate. In step 824, a permanent seam is optionally created in the non-breathable material of the lyophilization container. In step 826, the lyophilization container is optionally divided at the permanent seam, leaving the lyophilized end-product in the non-breathable section.

[0067] Notwithstanding the various specific embodiments enumerated in this disclosure, those skilled in the art will appreciate that a variety of modifications and optimizations could be implemented for particular applications without departing from the scope of this application. For instance, in alternative embodiments, the fill fixture may be adapted to fill multiple lyophilization containers simultaneously. Likewise, the fixture may be configured to accommodate the unique dimensions of any particular lyophilization container. In yet further embodiments, the gas fill fixture and other system components may include tabs, pins, clips or any other conventional attachment means configured to secure the lyophilization container in the correct position. Additionally, the present application is not limited to the lyophilization of blood or blood products. That is, the principles of the present application may be applicable to the lyophilization of many fluids. Accordingly, various modifications and changes may be made in the arrangement, operation, and details of the methods and systems of the present application which will be apparent to those skilled in the art.

WHAT IS CLAIMED IS:

1. A gas fill fixture for use in lyophilization, the gas fill fixture comprising:
a chassis;
fill indicator; and
a lid,
wherein the chassis and lid together form a cavity configured to receive a flexible lyophilization container placed along its longitudinal axis therein.
2. The fixture of claim 1, wherein the chassis comprises Acrylonitrile Butadiene Styrene (ABS).
3. The fixture of claim 1, wherein the fill indicator is a mechanical indicator.
4. The fixture of claim 3, wherein the mechanical indicator is a linear indicator.
5. The fixture of claim 4, wherein the linear indicator is configured to use multiple colors to indicate a proper fill condition and an overfilled condition.
6. The fixture of claim 1, wherein the fill indicator comprises at least one sensor.
7. The fixture of claim 6, wherein the at least one sensor is selected from among optical sensors, inductive sensors and capacitive sensors.
8. The fixture of claim 1, wherein the lid is connected to the chassis with at least one hinge.
9. The fixture of claim 8, wherein the at least one hinge is a pivot hinge.
10. The fixture of claim 1, further including a handle configured to cooperate with a lyophilization container.
11. A system for lyophilizing a fluid, the system comprising:
a lyophilization container;
a lyophilizer; and

- a gas fill fixture, the fixture including:
- a chassis,
 - fill indicator, and
 - a lid.
12. The system of claim 11, further comprising a lyophilization loading tray.
13. The fixture of claim 11, wherein the fill indicator is a mechanical indicator.
14. The fixture of claim 13, wherein the mechanical indicator is a linear indicator.
15. The fixture of claim 14, wherein the linear indicator is configured to use multiple colors to indicate a proper fill condition and an overfilled condition.
16. A method of lyophilizing a fluid, the method comprising:
- inputting a liquid into a flexible lyophilization container;
 - inputting a portion of the lyophilization container into a gas fill fixture;
 - inputting a gas into the lyophilization container;
 - determining an appropriate gas fill volume based on an indication from fill indicator of the gas fill fixture;
 - loading the lyophilization container into a lyophilizer; and
 - lyophilizing the fluid.
17. The method of claim 16, further comprising placing the lyophilization container on a lyophilization loading tray.
18. The method of claim 16, wherein the lyophilization container is a flexible, multi-part lyophilization container including a breathable section and non-breathable section.
19. The method of claim 16, wherein the inputting of liquid into the lyophilization container comprises inputting the liquid into the non-breathable section of the container.
20. The method of claim 16, wherein the fill indicator is a linear indicator.

21. The method of claim 20, wherein the linear indicator is configured to use multiple colors to indicate a proper fill condition and an overfilled condition.

22. The method of claim 16, wherein the lyophilizing the fluid comprises the steps of:
freezing the liquid;
removing an occlusion from the lyophilization container; and
applying heat energy and vacuum.

23. The method of claim 16, further comprising occluding the lyophilization container between breathable and non-breathable sections.

24. The method of claim 16, further comprising placing a portion of the lyophilization container over the fixture lid and into cooperation with a handle.

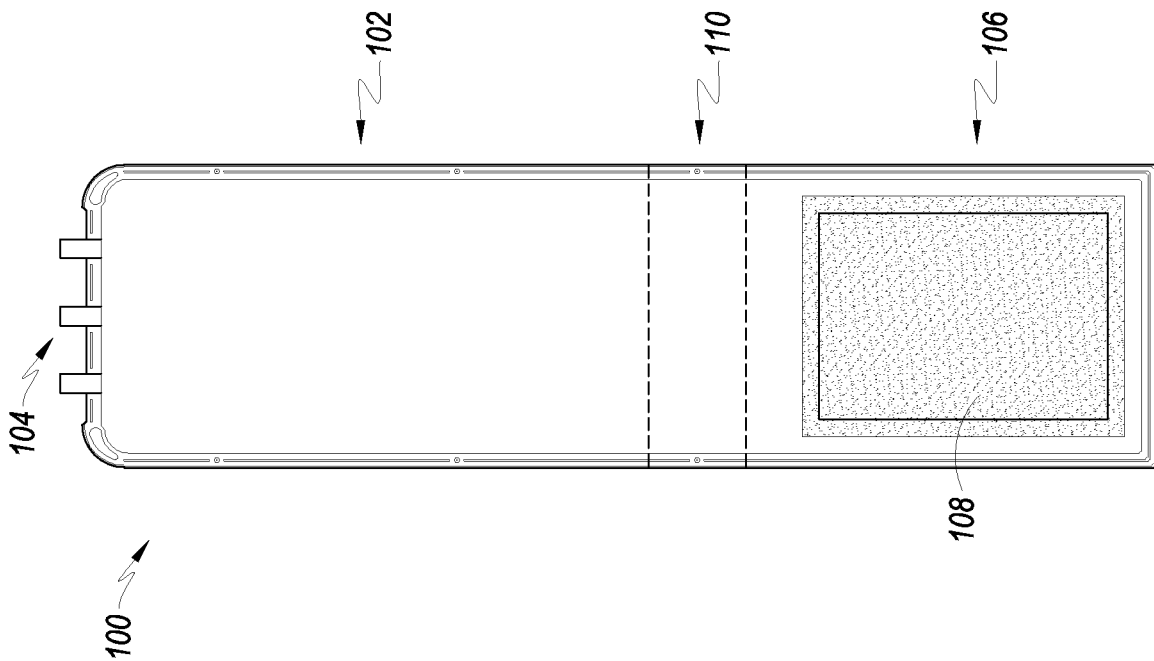

FIG. 1

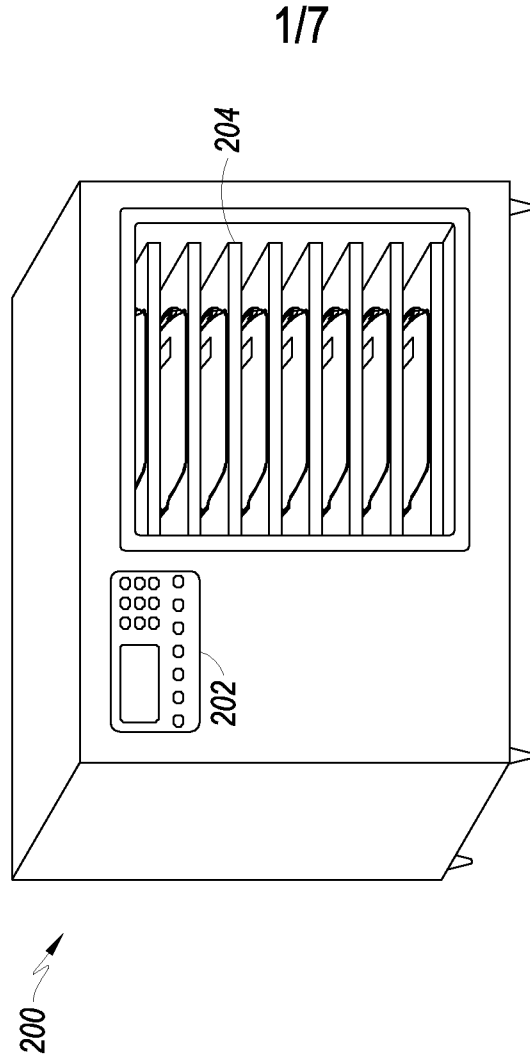

FIG. 2

RELATED ART

2/7

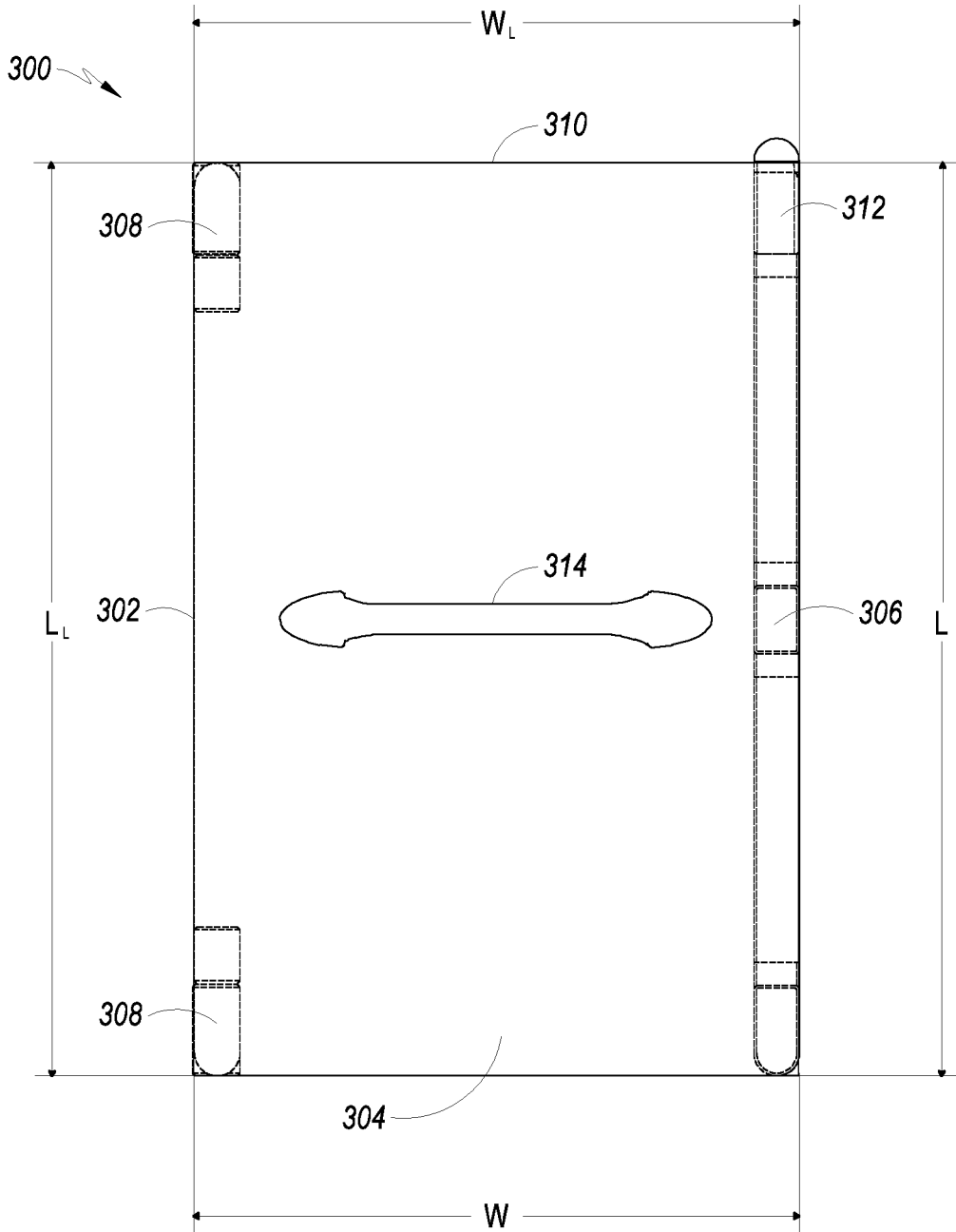

FIG. 3

3/7

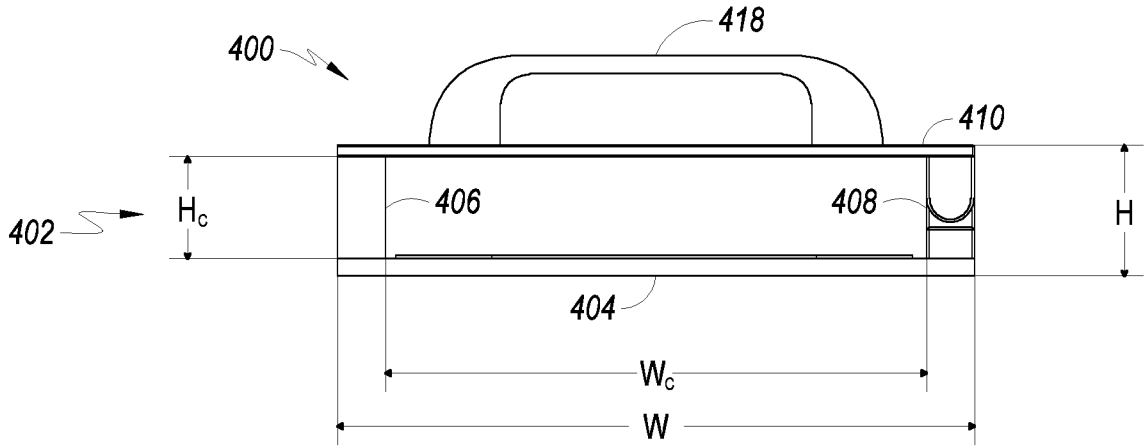

FIG. 4A

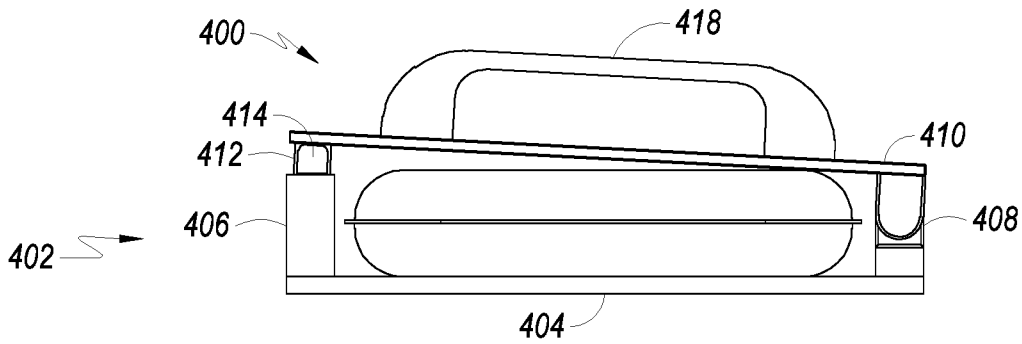

FIG. 4B

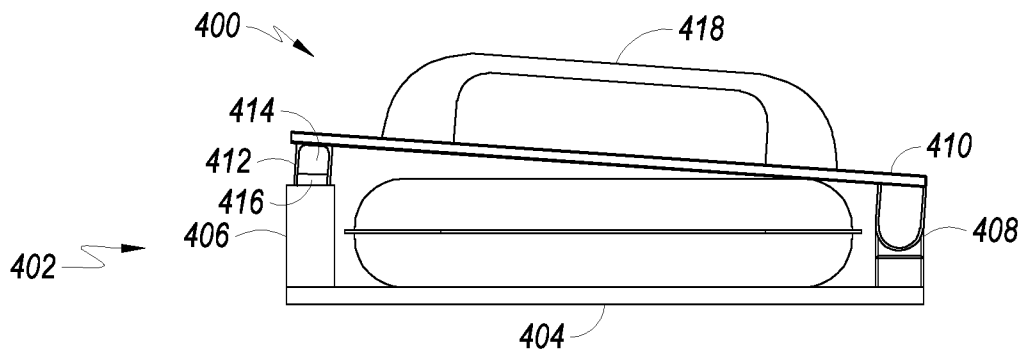

FIG. 4C

4/7

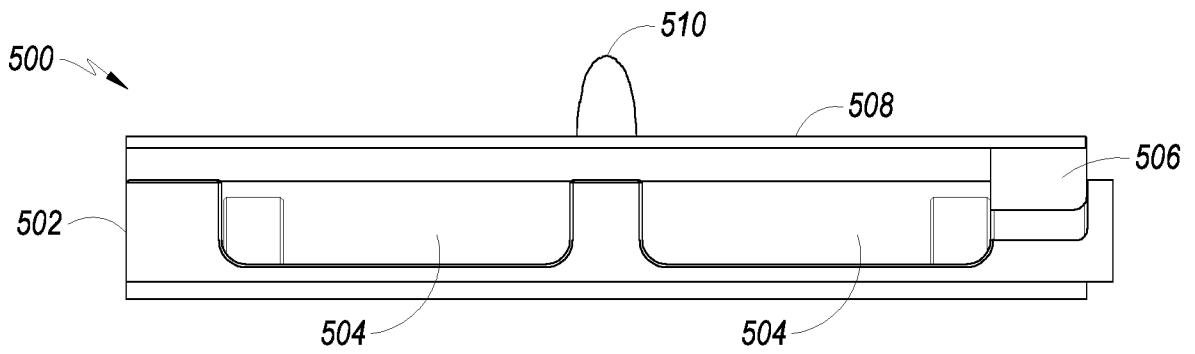

FIG. 5

5/7

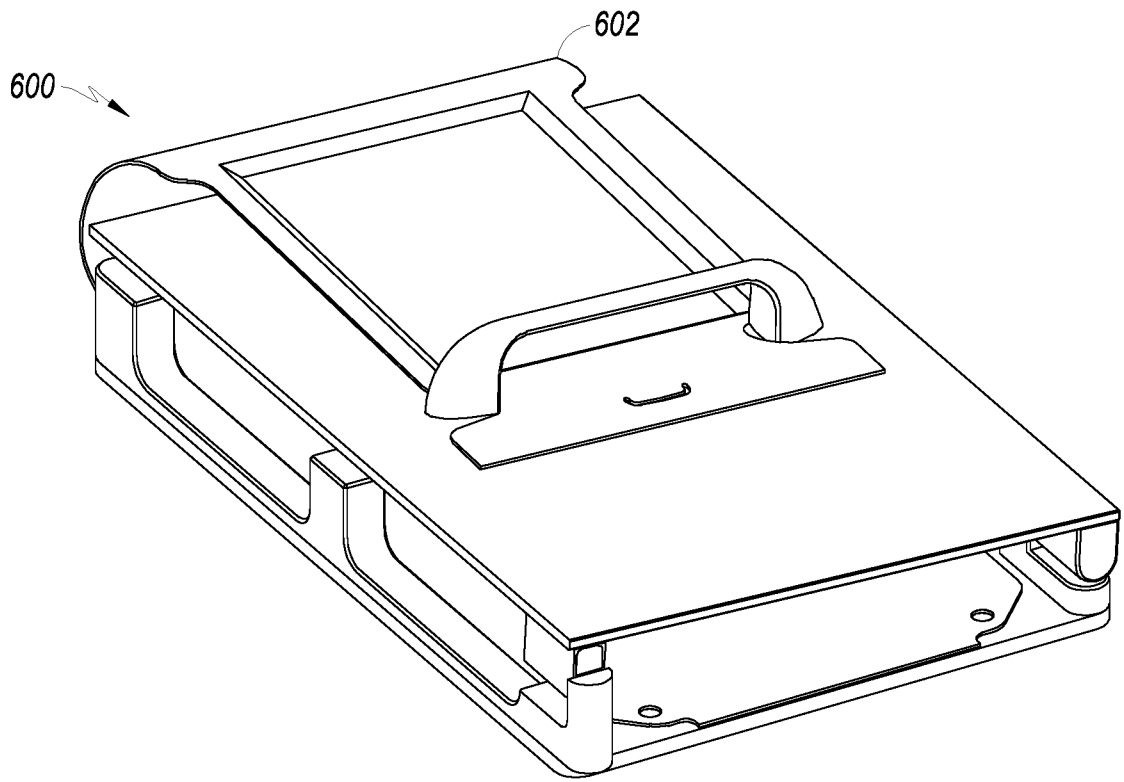

FIG. 6

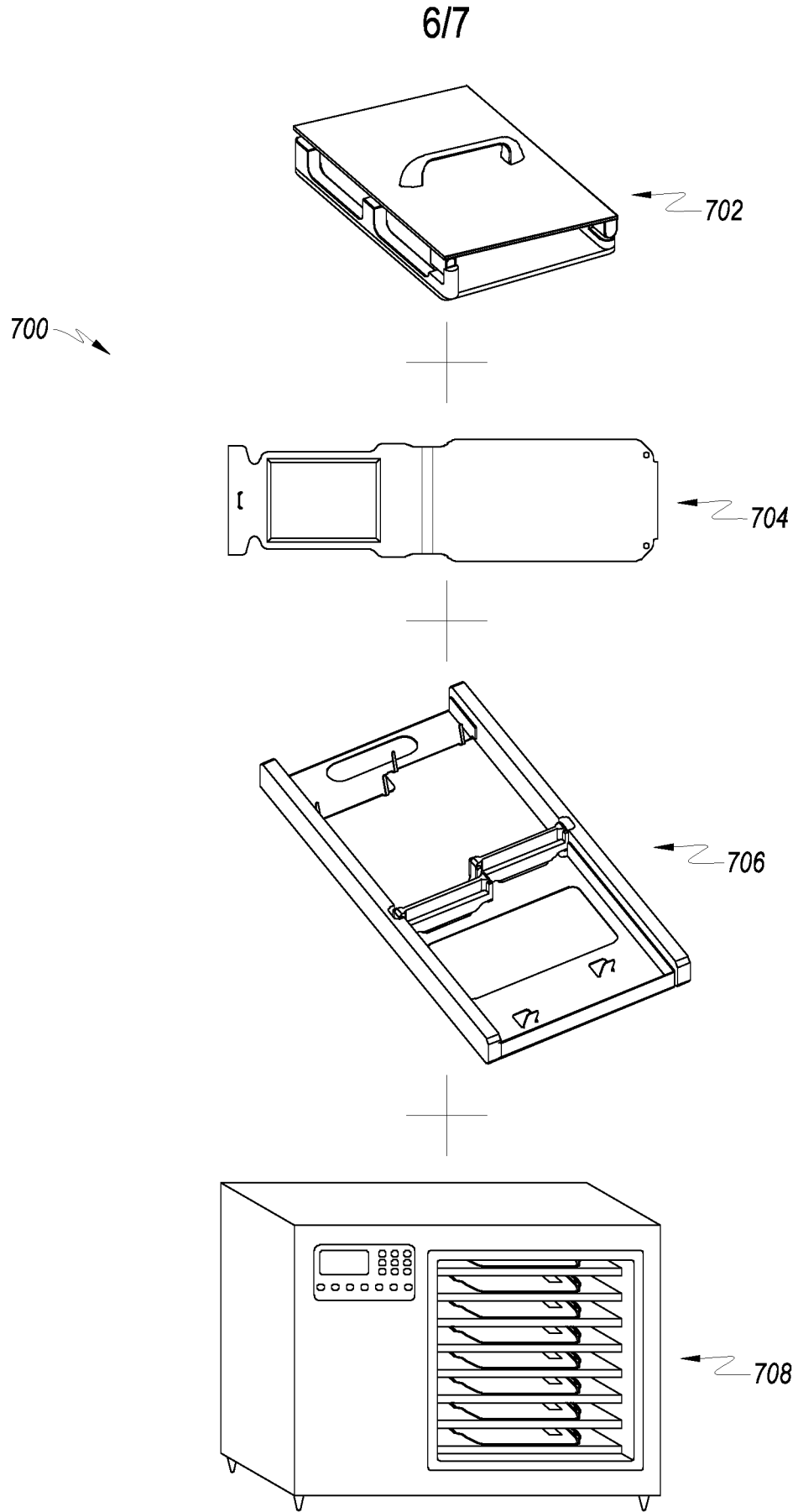

FIG. 7

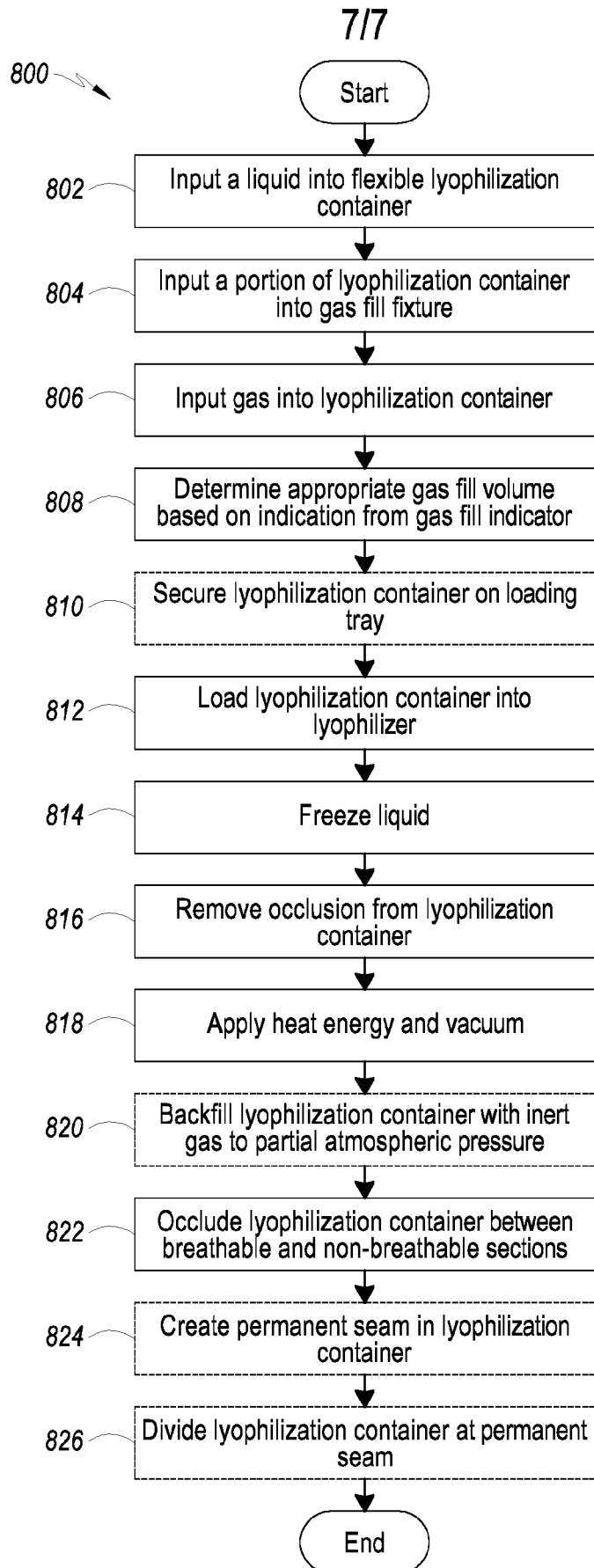

FIG. 8

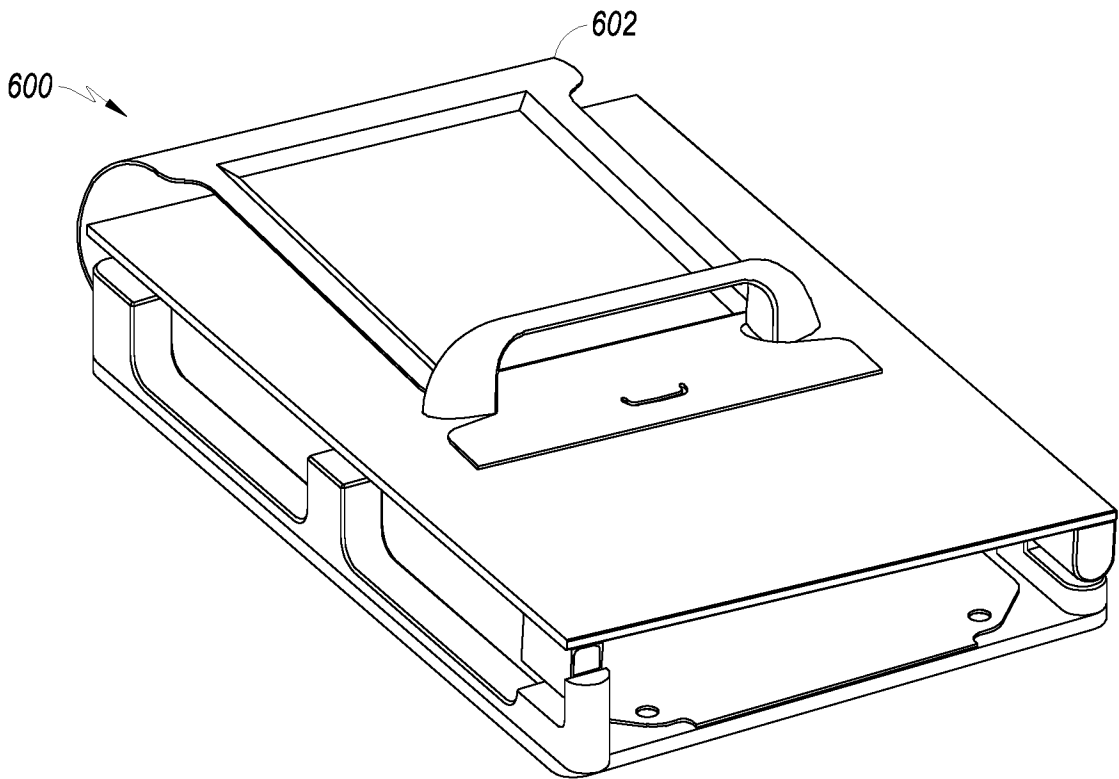

FIG. 6