

[54] JACK OR LIFT MECHANISM AND DRIVE THEREFOR

3,322,392 5/1967 Hoffman.....254/47
3,365,174 1/1968 Alsop.....254/95

[72] Inventor: Richard W. Boettcher, 18483 Ravenwood Drive, Saratoga, Calif. 95070

Primary Examiner—Robert C. Riordon
Assistant Examiner—David R. Melton
Attorney—Leslie M. Hansen

[22] Filed: Feb. 10, 1971

[21] Appl. No.: 114,196

[52] U.S. Cl.254/45, 74/89.21
[51] Int. Cl.B66f 7/26
[58] Field of Search254/45, 47, 95; 74/89.2, 89.21, 74/89.22, 99

[57] ABSTRACT

An extendable-retractable member telescopically guided for movement in a guide track having drive means affixed thereto and operatively associated with flexible linkage having its ends secured to the opposite ends of the member for extending and/or retracting the latter relative to the guide track.

[56] References Cited

UNITED STATES PATENTS

10 Claims, 6 Drawing Figures

3,118,321 1/1964 Rinke.....74/89.21 X

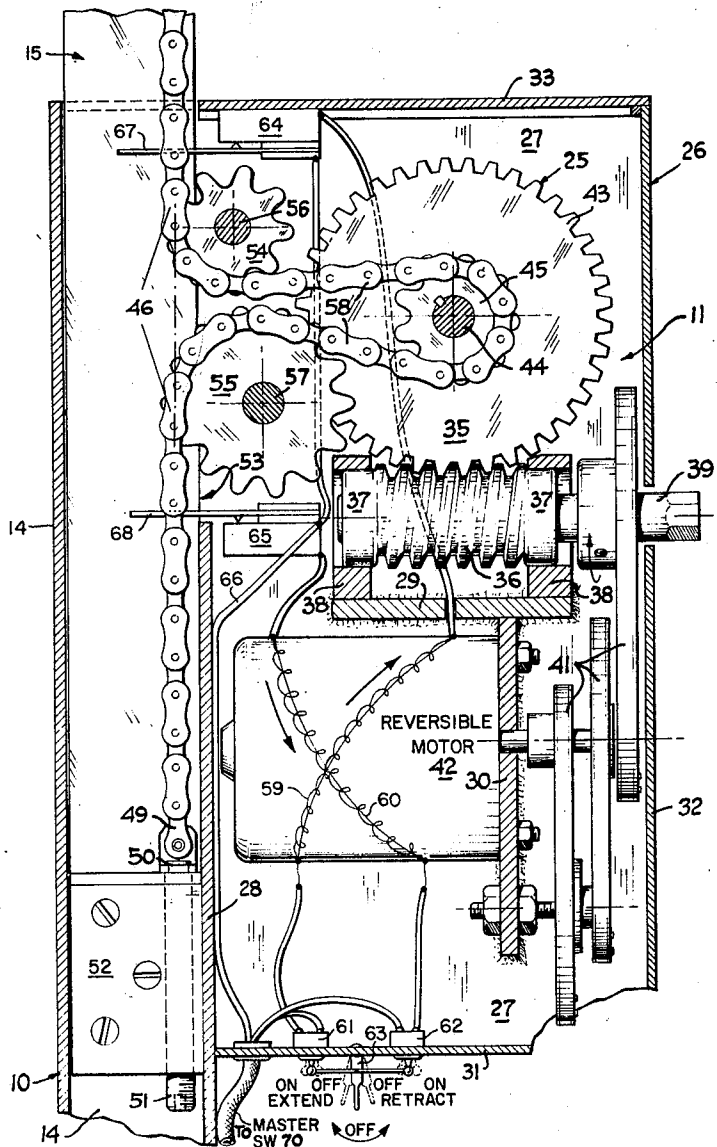

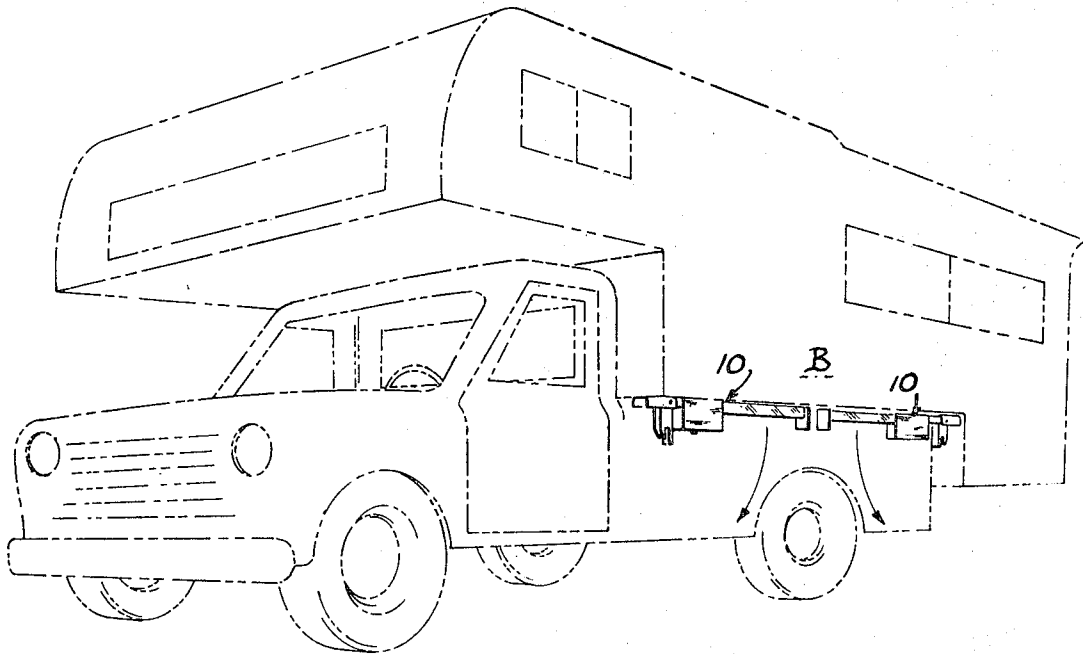

FIG. 1

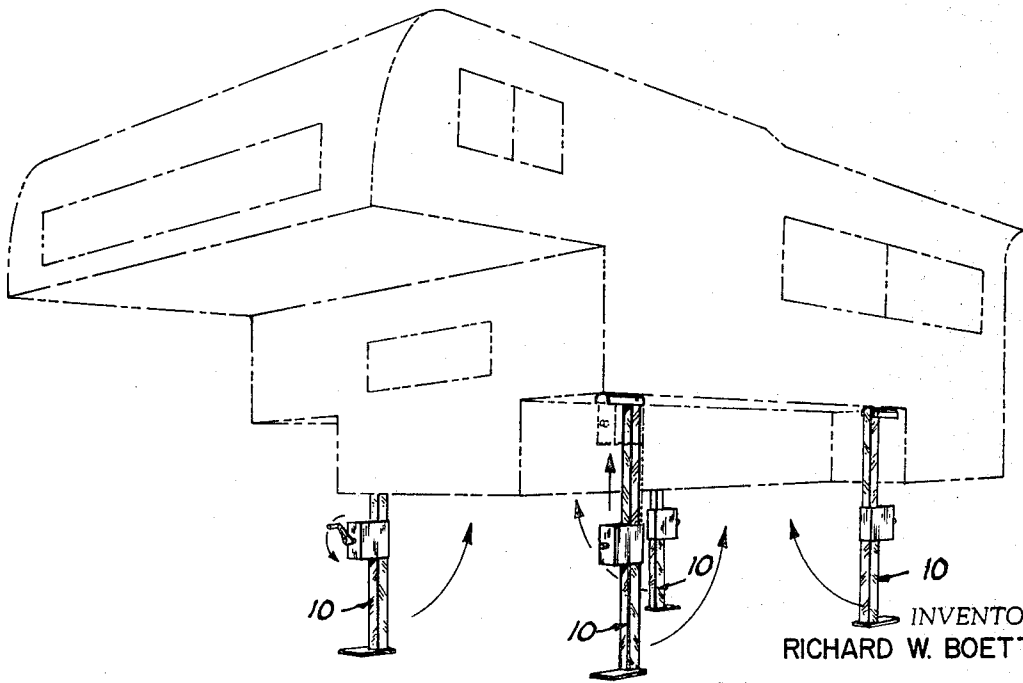
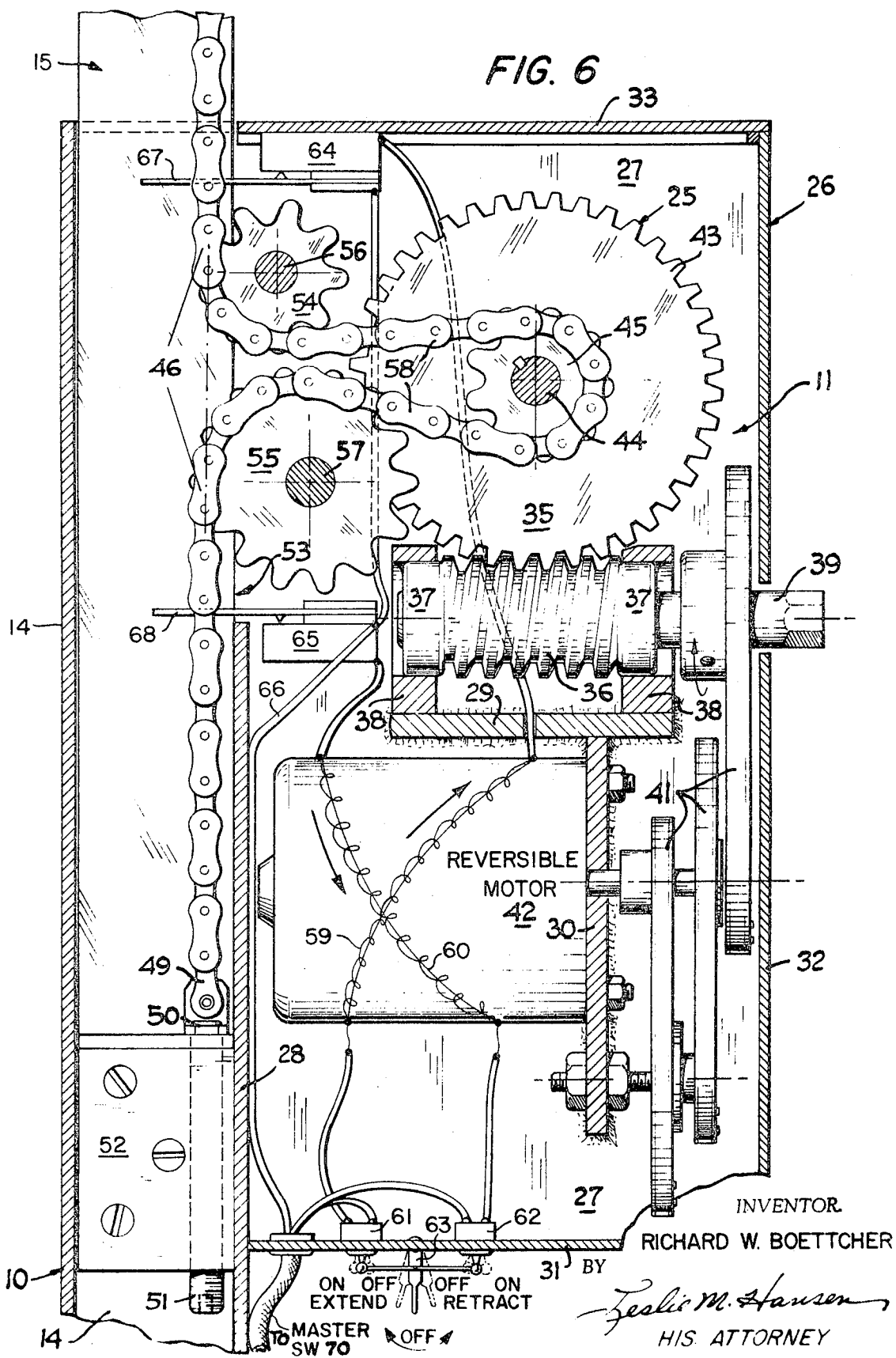

FIG. 2

INVENTOR.
RICHARD W. BOETTCHER

BY
Leslie M. Hansen
HIS ATTORNEY



JACK OR LIFT MECHANISM AND DRIVE THEREFOR

BACKGROUND

This invention relates to a lift mechanism and more particularly to an apparatus of the nature of a Jack for raising and lowering an object.

Broadly the present invention has its embodiment in a guide tube for a channel shaped member for extending and/or retracting the latter by means of a flexible connecting member drivingly associated with a drive mechanism on the guide tube. As exemplified in the present disclosure the mechanism is applied to a Jack having a base for the guide track and a channel member guided therein for use on a vehicle or any such load to be raised and/or lowered.

Prior known Jacks of this character are shown in several existing U.S. Patents. U.S. Pat. No. 3,350,063 to Thurlow shows an arrangement of hydraulically operated Jacks at four corners of a camper body in common system for operating all four jacks in unison. U.S. Pat. No. 3,338,554 to Gastomski shows screw type jacks within inner and outer sleeves united by a cable and driven by a winch for shortening and/or lengthening the cable to raise and lower a camper body. In another prior Pat. No. 3,164,407 issued to Schatz the ends of two cables connected to outer and inner telescoping tubes has their opposite ends wound inversely about the spool of a winch such that as one cable is paid out the other is wound upon the spool.

STATEMENT OF INVENTION

The present invention is related to a lift mechanism and is directed to a particular form of drive and connections therefor between a base and a member for raising and/or lowering a load to which it is applied.

It is an object of this invention to provide in a mechanism of the type having a rod guided for telescopic movement in a guide tract supporting a drive means operatively associated with a flexible linkage strung between the ends of the rod for extending and/or retracting the latter relative to the guide track.

More particularly it is an object of this invention to provide a drive means in fixed relation to the guide track and means for training a medial loop in the flexible linkage laterally into the drive means for altering the extendable and/or retractable disposition of the rod upon which the flexible linkage is strung.

It is yet another object to provide for such mechanism a worm gear drive means including a worm screw and means for either manually or mechano-electrically turning the worm screw.

It is a further object to provide means for limiting the extension and/or retraction of the guided member and means for controlling multiple units thereof.

It is a still further object to provide means for securing the guided member to a body to be lifted and means for providing a footing or foundation for the guide track and drive means affixed thereto.

These and other objects and advantages of the present invention will become more apparent from a reading of the following description and claims in the light of the accompanying three sheets of drawing in which:

FIG. 1 is a perspective view of a truck having a camper thereon provided with jacks embodying the lift mechanism of the present invention;

FIG. 2 is a perspective view of the camper supported on jacks involving the present embodiment;

FIG. 3 is a perspective view of one jack foreshortened for purpose of illustration;

FIG. 4 is a section through a hinge mount of FIG. 3;

FIG. 5 is a section through a latch for holding the jack in operative condition;

FIG. 6 is an enlarged section through a portion of the jack of FIG. 3 showing the lift mechanism of the present invention and taken substantially along line 6-6 of FIG. 3.

GENERAL DESCRIPTION

Referring to the drawings FIG. 3 shows a Jack 10 having a lift mechanism 11 comprising one application of the embodiment of the present invention. In general the Jack 10 includes a base 12 provided with a suitable footing 13 in the form of a flat plate secured to a tubular standard 14. The tubular standard 14 consists of a guide track for a lift rod 15 preferably in the form of a channel of a size to fit telescopically within the standard 14 for up and down guided movement therein and relative thereto. The upper end of the lift rod 15 is provided with a pad 16 adapted to have bearing relation to a body B to be raised and/or lowered by the lift mechanism.

In the present application the Jack 10 is shown to be for connection to the body B of a camper. For this reason the pad 16 is connected to the upper end of the lift rod 15 (FIGS. 1 to 3 and 4). As illustrated in FIGS. 1 and 2 a jack 10 is pivotally connected to each of the four corners of the camper body B for raising and/or lowering the same relative to a pickup truck conventionally used in combination with such campers.

Referring to FIGS. 3 and 4 the pad 16 is pivotally connected as at 17 to a channel shaped mounting 18 having its web secured by bolts 19 and the like to the underside of a portion of the body B of the camper. The upper pad 16 is shown as a channel shape adapted to nest into the channel mounting 18 which has its flanges hanging downwardly from its web. The flanges of the mounting 18 are provided with parallel slots 20 which support a latch bar 21 transversely of the channel 18. The bar 21 is spring urged toward the pivot pin 17. The pad 16 has the free ends of its flanges slotted as at 22 in conformity with the slots 20 in the mounting 18. The flanges of pad 16 have their extreme ends 23 tapered above the slots 22 for cammingly engaging the latch bar 21 when the pad 16 is forced into parallel relation to the mounting channel 18. By this arrangement the jack 10 is latched in operative position, i.e., vertically (FIGS. 2, 3 and 4) for raising and lowering the body B. When the jacks 10 are not in use they are swung up into parallel relation i.e., horizontal position, and secured by a hook 24 (FIGS. 3 and 5) connected to the body B of the camper. To release the latch bar 21, the latter is pulled outwardly along the slots 20-22 beyond the extreme cam ends 23 of the pad 16.

Referring now to FIG. 6 the lift mechanism 11 of the present invention comprises a drive means 25 supported on the standard 14 and operatively connected to the lift rod 15 for raising and lowering the latter relative to the standard 14. The drive means 25 is concealed within a housing 26 supported on the upper end of the standard 14. The housing 26 is constructed of a pair of side plates 27 secured by machine screws (FIG. 3) to opposite side walls of the tubular standard 14 and extending laterally from one side wall 28 of the standard. These side plates 27 are secured in spaced relation by a mounting shelf 29 and bracket 30 welded to the side plates for supporting the drive mechanism 25 therebetween. The side plates 27 also have their edges welded to a bottom member 31 and an end member 32. A top member 33 may be removable except when closed to completely conceal the drive mechanism within the housing 26 thus provided.

The drive mechanism 25 comprises a worm gear 35 including a worm screw 36 having its ends mounted on ball bearing rolls 37 supported in bosses 38 secured to the shelf 29. One end 39 of the worm screw extends beyond its boss 38 and through an opening in the end wall member 32 of the housing 26. The one end 39 of the worm screw 36 is keyed at its extremity to fit a crank handle 40 as illustrated in FIG. 3 for hand operation.

The worm screw 36 is also adapted for powered drive through a belt and pulley connection 41 to a reversible electric motor 42. To this end the belt and pulley arrangement 41 is in steps for increased power and to reduce the speed of the worm screw 36.

The worm gear 35 also includes a worm wheel 43 keyed to a cross shaft 44 suitably supported in bearings (not shown)

secured to the side plates 27. The worm wheel 43 has its teeth disposed in mesh with the thread of the worm screw 36 so as to be driven thereby. The cross shaft 44 also has a drive sprocket 45 keyed thereto. The drive sprocket 45 is of reduced pitch diameter relative to the worm wheel 43.

The worm gear 35 is operatively connected to a link chain 46 trained around the sprocket 45 and having one of its ends 47 anchored to the upper end of the lift rod 15 on a cross pin 48. The opposite end 49 of the chain 46 is secured to a swivel head 50 on an adjusting screw 51 threaded through an anchor block 52 secured to the lower end of the lift rod 15.

As best seen in FIG. 6 the chain 46 has a main strand stretched tightly parallel to and within the lift rod 15 adjacent that side wall 28 of the standard 14 from which the housing 26 extends.

The side wall 28 of the tubular standard 14 is open as at 53 adjacent its upper end in the region of the worm gear 35 within the housing 26. A pair of idler sprockets 54 and 55 each journaled on a separate cross shaft 56 and 57, respectively, have the pitch line of their teeth disposed tangent to the vertical strand of the chain 46 within the lift rod 15.

The idler sprockets 54 and 55 are spaced vertically from each other along a plane laterally of its main strand and radially from the cross shaft 44 of drive sprocket 45 and worm wheel 43. By this arrangement the normally vertical strand of the chain 46 has a section 58 thereof guided around the idler sprockets to form a loop extending into the housing 26 for entrainment about the drive sprocket 45. The arrangement is such that upon turning of the worm screw 36, the movement of the chain 46 relative to the drive mechanism 25 causes the lift rod 15 to move up and/or down relative to the standard 14. In other words, as the lower reach of the chain 46 is drawn into the housing 26 the upper reach therefrom is lengthened to thus raise the lift rod 15. When the worm screw 36 is turned in an opposite direction the upper reach of the chain 46 pays into the housing 26 while the lower reach of the chain lengthens to lower the lift rod 15 relative to the guide track 14.

As previously explained turning of the worm screw 36 may be done manually by means of the hand crank 40. It may also be turned mechanically by means of a source of power such as the electric motor 42. In the case of electrical operation of the lift mechanism 11, the motor 42 is of the reversible type having reversed windings in separate circuits 59 and 60 each controlled by a separate switch 61 and 62, respectively. The switches 61 and 62 are united by a common hand lever 63 such that when one switch (61) is on, the other switch (62) is off and vice versa. Each of the separate circuits 59 and 60 is provided with a limit switch 64 and 65, respectively, connected to a common ground wire 66.

The limit switch 64 is arranged within the housing 26 adjacent the upper end of the standard 14 and has a sensor arm 67 extending into the latter for engagement by the cross pin 48 to which the upper end of the chain 46 is anchored. The other limit switch 65 is arranged within the housing 26 below the lowermost idler sprocket 55 and has a sensor arm 68 extending into the standard 14 for engagement by the upper surface of the anchor block 52 adjacent the lower end of the chain 46.

By this arrangement the lift rod 15 will be limited in either upward or downward movement relative to the standard 14 within which it is guided. In the application of the lift mechanisms 11 to a camper body B as illustrated in FIGS. 1 and 2 the lift rods 15 being suspended from the mountings 18, it is the standards 14 which will be moved downward relative to the lift rods upon extension of the latter out of the standard. A master switch 70 in the camper B would first control the circuits 59 and 60 such that only after all jacks 10 are vertically disposed will the hand switch lever 63 function. If the standards 14 are all the way up upon the lift rods 15 the lower limit switch 65 will be in an off condition. Therefore, only the circuit 59 controlling the extension of the lift rod 15 relative to the standard will be in condition for operation, the upper limit switch 64 being closed. Consequently, upon closing of the extend switch 61 the winding of the motor 42 in circuit 59 will

turn the pulleys 41 and worm screw 36 in a direction to cause the standard 14 to walk down the chain 46. In the case of the jacks 10 being applied to a camper body B the maximum extension of the lift rods 15 relative to the standards 14 is calculated to elevate the camper body B out of the bed of the pickup vehicle sufficiently to support the camper independently thereof. It is conceivable that this can be done by all four jacks 10 operating simultaneously. For example, with the master switch 70 within the camper B turned off, no current will flow to either circuit 59 or 60 of any jack unit. Therefore, each of the extend switches 61 on all four jacks may be first turned on without any of the jacks functioning. However, when switch 70 is turned on, all four jacks will operate simultaneously to extend condition. When the jacks are fully extended the anchor blocks 52 on the lift rods 15 will automatically strike the respective sensor arms 68 of the lower limit switches 65 to shut off the circuit 59. Since the lift rod 15 is now extended the sensor arms 67 of the upper limit switches 64 will return to normal to condition the retract circuit 60 for use.

By the foregoing arrangement a body B, such as that of a camper may be raised, and/or lowered in a simple yet effective manner between limits. A camper body may thus be supported high enough to have a pick-up truck backed into position to receive the camper. With the panel body of such truck properly positioned, the retract switches 62 may be switched to on position to complete the retract circuit 60 to lower the camper body onto the truck bed.

While I have described the Jack or lift mechanism and drive means therefor in specific detail it will be appreciated that the same may be susceptible to alterations, variations and/or modifications without departing from the spirit or scope of my invention therein as called for in the appended claims.

What I claim as new and desire to protect by Letters Patent is:

1. An extendable-retractable mechanism in the nature of a jack and the like comprising:
 - a. a pair of members arranged for movement lengthwise relative to each other;
 - b. a drive mechanism mounted on one of said members including powered means laterally thereof;
 - c. a strand of flexible linkage having its opposite ends secured to the ends of the other one of said members;
 - d. a pair of idler wheels mounted on said drive mechanism in spaced relation relative to each other and in tangential engagement with the strand of flexible linkage between the ends of said other one of said members; and
 - e. a medial portion of said flexible linkage extending from said idler wheels laterally into said drive mechanism and trained about said powered means for lengthening one end of said strand of flexible linkage and shortening the opposite end of said flexible linkage relative to its medial portion for extending and retracting said pair of members relative to each other.
2. The mechanism in accordance with that of claim 1 in which one of said pair of members has footing means thereon adapted for engaging a firm foundation and in which the other one of said members has means thereon for bearing against a body to be moved relative to said footing means.
3. The mechanism in accordance with that of claim 2 in which said guide track member has said drive mechanism and powered means secured thereto and has the other one of said members guided for sliding movement lengthwise relative to said guide track by the entrainment of the medial portion of said flexible linkage about said powered means.
4. The mechanism in accordance with that of claim 3 in which said drive mechanism and powered means comprises:
 - a. a housing mounted on said guide track member so as to extend laterally therefrom;
 - b. a worm gear mounted within said housing having a worm screw disposed with its axis extending normal relative to said guide track member, and a worm wheel journaled within said housing transversely of said worm screw and in mesh therewith;

- c. drive means secured concentric to said worm wheel affording entrainment of the medial portion of said flexible linkage thereabout; and
- d. means for turning said worm screw.

5. The mechanism in accordance with that of claim 4 in which said means for turning said worm screw comprises a reversible electric motor, and a belt and pulley drive connection between said motor and said worm screw.

6. The mechanism in accordance with that of claim 5 in which said flexible linkage is a link chain, and in which said drive means secured to said worm wheel is a sprocket having the laterally extending medial portion of said chain looped about it, and in which said idler wheels are idler sprockets for said link chain.

7. The mechanism in accordance with that of claim 5 including reversible electrical circuits for said electrical motor, and a limit switch in each of said reversible electrical circuits for limiting the extension and retraction of said pair of members relative to each other.

8. The jack mechanism in accordance with that of claim 7 in

which said guide track member has an earth engaging foot at one end thereof and in which the other one of said members guided in said guide track has a body engaging pad on that end thereof opposite to the earth engaging foot on said guide track, and means for pivotally securing said pad to the underside of a body to be moved.

9. The jack means in accordance with that of claim 8 including a hook means of such body in spaced relation to said means for pivotally securing said pad to the body a distance substantially equal to the length of said pair of members in retracted condition for temporarily securing said jack mechanism in storage condition on said body.

10. The jack mechanism in accordance with that of claim 9 including a releasable latch means on said means for pivotally securing said pad to the body, and cam means on said pad for engaging said releasable latch means upon arrival of said jack mechanism from storage to operative condition for securing the jack mechanism to enable movement of the body upon extension and retraction of the jack mechanism.

* * * * *

25

30

35

40

45

50

55

60

65

70

75