



US00D897151S

(12) **United States Design Patent**
Bullock et al.

(10) **Patent No.:** **US D897,151 S**

(45) **Date of Patent:** **** Sep. 29, 2020**

(54) **LID**

FOREIGN PATENT DOCUMENTS

(71) Applicant: **YETI Coolers, LLC**, Austin, TX (US)

AU 2017280047 A1 1/2019
AU 2016368382 B2 2/2019

(Continued)

(72) Inventors: **Dustin Bullock**, Austin, TX (US);
Steve Charles Nichols, Austin, TX
(US); **Edward Abante**, Austin, TX
(US); **Evan Goldberg**, Austin, TX (US)

OTHER PUBLICATIONS

Youtube. Yeti Rambler R12 Bottle with Hotshot Cap Demo, Features & Review by Tentworld—The Camping Experts. Oct. 30, 2019. <https://www.youtube.com/watch?v=cLZsvhUMydM> (Year: 2019).*

(Continued)

(73) Assignee: **YETI Coolers, LLC**, Austin, TX (US)

(**) Term: **15 Years**

(21) Appl. No.: **29/667,017**

Primary Examiner — Darcy E Gottschalk

(74) *Attorney, Agent, or Firm* — Banner & Witcoff, Ltd.

(22) Filed: **Oct. 17, 2018**

(57)

CLAIM

The ornamental design for a lid, as shown and described.

(51) **LOC (12) Cl.** **07-99**

DESCRIPTION

(52) **U.S. Cl.**

USPC **D7/396.2**; D9/449; D9/443

(58) **Field of Classification Search**

USPC D7/392, 392.1, 396.2; D9/434–436, 443,
D9/447, 449, 454, 499, 439, 440

CPC A47G 21/18; A47G 19/2266
See application file for complete search history.

FIG. 1 is a top, front, right perspective view of a lid showing our new design;

FIG. 2 is a front view thereof;

FIG. 3 is a right side view thereof;

FIG. 4 is a rear view thereof;

FIG. 5 is a left side view thereof;

FIG. 6 is a top view thereof;

FIG. 7 is a top, front, right perspective view of a lid showing our new design in its exemplary environment;

FIG. 8 is a top, front, right perspective exploded view of a lid showing our new design;

FIG. 9 is a front view thereof;

FIG. 10 is a right side view thereof;

FIG. 11 is a rear view thereof;

FIG. 12 is a left side view thereof;

FIG. 13 is a top view thereof; and,

FIG. 14 is a top, front, right perspective exploded view of a lid showing our new design in its exemplary assembly.

The broken lines depicting the remainder of the lid show features that form no part of the claimed design.

(56) **References Cited**

U.S. PATENT DOCUMENTS

1,477,936 A	12/1923	Bolt
D101,575 S	10/1936	Windbiel
D109,331 S	4/1938	McManus et al.
D154,378 S	7/1949	Fuller
2,735,566 A	2/1956	Bramming
D177,761 S	5/1956	Reinhardt
2,804,103 A	8/1957	Wall
2,881,776 A	4/1959	Wrage
2,957,596 A	10/1960	Rehborg
2,963,187 A	12/1960	Bramming
3,089,603 A	5/1963	Leslie-Smith
3,140,799 A	7/1964	Mehr

(Continued)

1 Claim, 14 Drawing Sheets

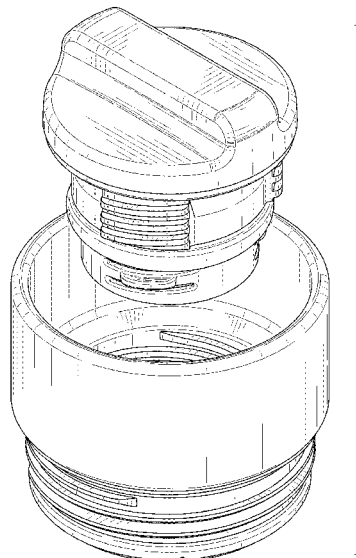

(56)

References Cited

U.S. PATENT DOCUMENTS

3,141,586	A	7/1964	Wetters	D458,134	S	6/2002	Berish et al.	
3,220,695	A	11/1965	Downey et al.	D466,814	S	12/2002	Hurlburt	
3,239,090	A	3/1966	Bramming	6,530,496	B2	3/2003	Moran	
3,249,268	A	5/1966	Neuner	6,536,618	B1	3/2003	Hwang et al.	
3,285,453	A	11/1966	Wagner	D475,924	S	6/2003	Haffner	
3,307,752	A	3/1967	Anderson	D476,890	S	7/2003	Hirose	
3,439,843	A	4/1969	Corsette	6,601,740	B1	8/2003	Clive	
3,456,840	A	7/1969	McAlaster	D479,800	S	9/2003	McRae	
3,592,349	A	7/1971	Baugh	D479,995	S	9/2003	Duceppe	
3,638,821	A	2/1972	Guala	D482,607	S	11/2003	McRae	
D224,646	S	8/1972	Vollquartz	6,648,158	B1	11/2003	Lawrence	
3,752,347	A	8/1973	Bell	6,662,978	B2	12/2003	Lin et al.	
3,776,433	A	12/1973	De Treitas	6,675,998	B2	1/2004	Forsman et al.	
3,785,539	A	1/1974	Wetters	6,702,138	B1	3/2004	Bielecki et al.	
3,842,790	A	10/1974	Clark	D490,275	S	5/2004	Moran	
3,863,798	A	2/1975	Kurihara et al.	D494,064	S	8/2004	Hook	
3,874,541	A	4/1975	Lagneaux et al.	D494,425	S	8/2004	Segura	
D235,303	S	6/1975	Boucher	6,908,015	B2	6/2005	Choi et al.	
D248,373	S	7/1978	Allen	D507,495	S	7/2005	Williams et al.	
4,190,173	A	2/1980	Mason et al.	D511,457	S	11/2005	Biesecker et al.	
D256,651	S	9/1980	Leung et al.	D521,314	S	5/2006	Ball	
4,358,024	A	11/1982	Underwood	D524,909	S	7/2006	Bakke et al.	
4,497,422	A	2/1985	Klees	D525,518	S	7/2006	Baldwin	
D279,346	S	6/1985	Ruxton	D530,141	S	10/2006	Wilgus et al.	
D281,567	S	12/1985	Zimmermann	D533,032	S	12/2006	Liu et al.	
D286,604	S	11/1986	Bierlein et al.	D536,929	S	2/2007	Kingsley	
D286,847	S	11/1986	Zimmermann	D536,974	S	2/2007	Smith et al.	
D287,211	S	12/1986	Weiss	7,172,101	B2	2/2007	Find	
D289,614	S	5/1987	Sanchez et al.	D537,714	S	3/2007	Yerby et al.	
D292,492	S	10/1987	Ross et al.	D540,625	S	4/2007	Sandberg	
4,723,677	A	2/1988	Nagel, Jr.	D548,006	S	8/2007	Lapsker	D7/392.1
4,981,233	A	1/1991	Scheurer	D548,082	S	8/2007	Kingsley	
D321,628	S	11/1991	Kobayashi et al.	D549,444	S	8/2007	Schnackenberg	
D325,167	S	4/1992	Humfress	7,270,244	B1	9/2007	Liu	
5,105,975	A	4/1992	Patterson	D553,914	S	10/2007	Wahl	
D329,809	S	9/1992	Bloomfield	D554,000	S	10/2007	Walsh	
D332,379	S	1/1993	Murphy	D557,994	S	12/2007	Wahl	
5,190,178	A	3/1993	Luch	D564,363	S	3/2008	Rhea	
5,211,299	A	5/1993	Manfredonia	D567,007	S	4/2008	Bodum	
5,232,112	A	8/1993	Howard	D567,021	S	4/2008	Bach et al.	
5,249,703	A	10/1993	Karp	D569,195	S	5/2008	Kim	
5,251,788	A	10/1993	Moore	D572,585	S	7/2008	Perrin et al.	
D354,915	S	1/1995	Schneider et al.	D574,237	S	8/2008	Yates, III	
5,392,967	A	2/1995	Satomi et al.	D581,211	S	11/2008	Lapsker	D7/396.2
D361,265	S	8/1995	Doxey	D582,206	S	12/2008	Fuller	D7/392.1
5,490,622	A	2/1996	Tardif	D583,200	S	12/2008	Moran	
D368,224	S	3/1996	Arndt	7,458,486	B2	12/2008	Weist et al.	
5,498,333	A	3/1996	Canther	D584,623	S	1/2009	Chupak	
D370,629	S	6/1996	Lynch	D586,183	S	2/2009	Junkel	
5,605,241	A	2/1997	Imperioli	D587,533	S	3/2009	Carreno	
D384,280	S	9/1997	Kuczer	D589,348	S	3/2009	Miller et al.	
D398,193	S	9/1998	Sanchez	D594,346	S	6/2009	Mouquet	
5,813,557	A	9/1998	Oratz	D599,616	S	9/2009	Cresswell et al.	
5,839,611	A	11/1998	Obadia et al.	D601,436	S	10/2009	Stephens et al.	
D402,510	S	12/1998	Miller	D603,331	S	11/2009	Schupp	
D405,642	S	2/1999	Toriba	D603,722	S	11/2009	Reimer	
D405,650	S	2/1999	Meier	D604,181	S	11/2009	Reimer	
D407,211	S	3/1999	Diviak, Sr.	D604,561	S	11/2009	Chisholm	
D407,273	S	3/1999	Moran	D605,040	S	12/2009	Fry et al.	
D410,175	S	5/1999	Moran	D605,060	S	12/2009	Reimer	
5,909,820	A	6/1999	Yeh	D605,942	S	12/2009	Miksovsky	
D415,395	S	10/1999	Hunt et al.	D610,871	S	3/2010	Alviar et al.	
D415,936	S	11/1999	Moran	D611,346	S	3/2010	Camomile	
D422,916	S	4/2000	Herrmann	D612,197	S	3/2010	Chan	D7/392.1
6,079,589	A	6/2000	Matsuyama et al.	D612,235	S	3/2010	Cresswell et al.	
6,102,227	A	8/2000	Cochrane	D612,660	S	3/2010	Bodum	
6,102,244	A	8/2000	Kuwano et al.	D614,918	S	5/2010	Chisholm	
D437,528	S	2/2001	Kitamura et al.	D614,955	S	5/2010	Cresswell	D9/447
6,264,072	B1	7/2001	Johannes	D615,360	S	5/2010	Joy et al.	
D447,410	S	9/2001	Malmborg	D615,361	S	5/2010	Goble	
6,321,924	B1	11/2001	Yurkewicz et al.	D615,816	S	5/2010	Joy et al.	
6,332,557	B1	12/2001	Moran	D616,703	S	6/2010	Joy et al.	
6,357,628	B1	3/2002	Long, Jr.	D616,743	S	6/2010	Cresswell et al.	
D456,669	S	5/2002	Munari	D616,744	S	6/2010	Cresswell et al.	
D458,133	S	6/2002	Berish et al.	D619,457	S	7/2010	Walsh	
				D619,458	S	7/2010	Walsh	
				D619,459	S	7/2010	Walsh	
				D620,798	S	8/2010	Cresswell et al.	
				D621,207	S	8/2010	Bodum	D7/392.1

(56)

References Cited

U.S. PATENT DOCUMENTS

D621,257 S	8/2010	Gullickson et al.	D668,913 S	10/2012	Mayer
D621,258 S	8/2010	Gullickson et al.	8,292,133 B2	10/2012	Baughman et al.
D621,648 S	8/2010	Lown et al.	D670,137 S	11/2012	Gilbert
D622,089 S	8/2010	Daniel et al.	D671,372 S	11/2012	Zou
D622,145 S	8/2010	Walsh	D672,238 S	12/2012	Aziz et al.
D623,475 S	9/2010	Aarnoudse et al.	D672,609 S	12/2012	Aziz et al.
D623,480 S	9/2010	Moran	D673,459 S	1/2013	Moran, Sr.
D623,481 S	9/2010	Moran	D675,100 S	1/2013	Herbst
D625,560 S	10/2010	Olson et al.	D675,865 S	2/2013	Wahl
D626,414 S	11/2010	Cresswell et al.	D676,706 S *	2/2013	Kern D7/392
D626,416 S	11/2010	Cresswell et al.	D676,764 S	2/2013	Moore et al.
D627,601 S	11/2010	Eyal	D677,103 S	3/2013	Melzer
D627,602 S	11/2010	Eyal	D677,119 S	3/2013	Ying
D627,604 S	11/2010	Eyal	D678,729 S	3/2013	Peeters et al.
D628,018 S	11/2010	Gilbert	D678,772 S	3/2013	Johnson et al.
D628,486 S	12/2010	Lane	D679,185 S	4/2013	Brown et al.
D628,898 S	12/2010	Barnett et al.	D680,389 S	4/2013	Zemel et al.
D628,900 S	12/2010	Barnett et al.	D682,016 S	5/2013	Knight
D628,901 S	12/2010	Barnett et al.	D682,617 S	5/2013	Miksovsky et al.
D629,689 S	12/2010	Cresswell et al.	8,443,993 B1	5/2013	Desselle
D629,690 S	12/2010	Cresswell et al.	8,443,994 B1	5/2013	Desselle
D629,691 S	12/2010	Cresswell et al.	D684,059 S	6/2013	Johnson et al.
D630,474 S	1/2011	Gilbert	8,459,468 B2	6/2013	Lin
D630,475 S	1/2011	Lu	D686,078 S	7/2013	Johnson et al.
D631,349 S	1/2011	Arnell et al.	D688,093 S	8/2013	Roth et al.
7,870,968 B2	1/2011	Hanson	8,505,760 B2	8/2013	Ott
D631,666 S	2/2011	Lim et al.	8,505,787 B2	8/2013	Fox et al.
D633,338 S	3/2011	Rosbach et al.	D690,987 S	10/2013	Gallen
D633,794 S	3/2011	Cresswell et al.	D690,988 S *	10/2013	Audette D7/392.1
D633,795 S	3/2011	Cresswell et al.	D691,848 S *	10/2013	Trudeau D7/392.1
D633,796 S	3/2011	Cresswell et al.	8,550,269 B2	10/2013	Lane
D633,797 S	3/2011	Cresswell et al.	D693,628 S *	11/2013	Tavener D7/392.1
D634,156 S	3/2011	Fuller et al.	D693,698 S	11/2013	Miller, Jr.
D634,160 S	3/2011	Cetera	8,584,902 B2	11/2013	Dejonge
D635,457 S	4/2011	Lane	D695,138 S	12/2013	Ball
D635,856 S	4/2011	Lauret	8,613,369 B2	12/2013	Kitto
D638,695 S	5/2011	Woodrow et al.	D696,945 S	1/2014	Newman
D638,708 S	5/2011	Walsh	D697,404 S	1/2014	Johnson et al.
D639,164 S	6/2011	Walsh	D697,802 S	1/2014	Lane
D639,177 S	6/2011	Pape	8,622,229 B2	1/2014	Lane
D639,661 S	6/2011	Llerena	D698,668 S	2/2014	Vaughn
D639,663 S	6/2011	Llerena	D701,464 S	3/2014	Ogata et al.
D640,466 S	6/2011	Staton	D702,092 S	4/2014	Mettler et al.
D641,257 S	7/2011	Thiebaut et al.	D702,506 S	4/2014	Mettler et al.
D641,591 S	7/2011	Tsukida	8,695,822 B2	4/2014	Kwon
D643,691 S	8/2011	Selina et al.	8,701,881 B2	4/2014	Gibson et al.
D643,693 S	8/2011	Jama	8,701,924 B2	4/2014	Dalbec
D645,709 S	9/2011	Endo	8,708,176 B2	4/2014	Andis
8,011,535 B2	9/2011	Tauber et al.	D703,998 S	5/2014	Funnell, II et al.
D648,984 S	11/2011	Gullickson et al.	8,720,730 B2	5/2014	Bodden, Jr.
D651,050 S	12/2011	Goshi	8,752,720 B1	6/2014	Habig et al.
D651,847 S	1/2012	Gilbert	D708,484 S	7/2014	Bishop
D652,255 S	1/2012	Carland	D708,914 S	7/2014	Moran, Sr.
D652,682 S	1/2012	Eyal	D708,954 S	7/2014	Barnes et al.
D653,499 S	2/2012	Dietterle et al.	D709,734 S	7/2014	Kotani
D654,762 S	2/2012	Gilbert	8,777,031 B2	7/2014	Aneas
D655,134 S	3/2012	Gilbert	D712,254 S	9/2014	Geis et al.
D655,581 S	3/2012	Kotani	D712,255 S	9/2014	Geis et al.
D657,196 S	4/2012	Beyers, III	D713,268 S	9/2014	Jones et al.
D658,064 S	4/2012	Barnes et al.	D713,365 S	9/2014	Green
D658,445 S	5/2012	Carreno	8,833,586 B2	9/2014	Meyers et al.
D659,007 S	5/2012	Pape	D714,584 S	10/2014	Boroski
D660,084 S	5/2012	Gilbert	D717,102 S	11/2014	Taketani et al.
8,177,097 B2	5/2012	Duran	D717,601 S	11/2014	Dixon
D662,360 S	6/2012	George	D719,780 S	12/2014	Sullivan
8,210,572 B2	7/2012	Davis	8,905,252 B2	12/2014	Latham et al.
8,215,511 B1	7/2012	Lin	D724,385 S	3/2015	Hurley et al.
D664,809 S	8/2012	Eyal	D724,435 S	3/2015	Kaufman et al.
D665,621 S	8/2012	Eyal	8,967,414 B2	3/2015	Lane
8,245,600 B2	8/2012	Beard	8,985,406 B2	3/2015	Tachi
8,245,870 B2	8/2012	McKinney et al.	D728,315 S	5/2015	Bo
8,251,247 B1	8/2012	Breckner	D728,995 S	5/2015	Barberi
D666,908 S	9/2012	Dabah et al.	D729,579 S	5/2015	Molayem
8,256,631 B2	9/2012	Hoffmann et al.	D729,584 S	5/2015	Weston et al.
8,272,532 B2	9/2012	Michaelian et al.	D732,402 S	6/2015	Jones et al.
			D734,154 S	7/2015	Johnson et al.
			D734,638 S	7/2015	Wahl
			D735,033 S	7/2015	Lynd et al.
			D735,038 S	7/2015	Tamarindo

(56)

References Cited

U.S. PATENT DOCUMENTS

D735,578 S	8/2015	Mazurkiewicz et al.	D820,039 S	6/2018	Fitzsimons
9,113,698 B2	8/2015	Blain et al.	10,029,832 B2	7/2018	Isogai
9,126,731 B2	9/2015	Chen	10,040,593 B2	8/2018	Ross et al.
D741,655 S	10/2015	Whelan et al.	D831,434 S	10/2018	Washburn et al.
D743,255 S	11/2015	Niggemyer	10,086,980 B2	10/2018	Isogai
D743,742 S	11/2015	Rummel et al.	D834,938 S	12/2018	Barnes et al.
D744,781 S	12/2015	Rummel et al.	D835,937 S	12/2018	Nichols
9,205,445 B2	12/2015	Fang et al.	D836,387 S	12/2018	Silsby et al.
9,215,942 B2	12/2015	Bodum	D836,388 S	12/2018	Abante et al.
D748,472 S	2/2016	Seybel et al.	D836,389 S	12/2018	Abante et al.
D748,955 S	2/2016	Oliver	10,167,120 B1	1/2019	Levy et al.
D751,345 S	3/2016	Lane et al.	10,183,791 B2	1/2019	Friedrich et al.
D751,399 S	3/2016	Lynd et al.	10,189,619 B1	1/2019	Crawley
D751,898 S	3/2016	D'Anglade	10,196,179 B2	2/2019	Wisniewski
9,272,822 B2	3/2016	Samartgis	10,196,185 B2	2/2019	Zoppas
D754,472 S	4/2016	Munari	10,196,186 B2	2/2019	Cox
D755,561 S	5/2016	Eyal	10,202,224 B2	2/2019	Painchaud
D757,543 S	5/2016	Sorensen et al.	10,214,323 B2	2/2019	Conley et al.
9,346,591 B2	5/2016	Martinengo	D842,030 S	3/2019	Meyers
D758,136 S	6/2016	Liotta et al.	D842,038 S	3/2019	Seiders et al.
D758,790 S	6/2016	Boroski	2002/0014498 A1	2/2002	Forsman et al.
D758,791 S	6/2016	Hanna et al.	2003/0141321 A1	7/2003	Sekendur
D758,804 S	6/2016	Liotta et al.	2003/0155323 A1	8/2003	Ekkert
D758,859 S	6/2016	Sorensen et al.	2004/0016715 A1	1/2004	Strikovic
D759,487 S	6/2016	Jayakaran	2004/0201224 A1	10/2004	Chang
9,376,243 B2	6/2016	Cervený	2004/0206721 A1	10/2004	Swanberg et al.
D760,586 S	7/2016	Seiders et al.	2005/0274741 A1	12/2005	Cho
D761,624 S	7/2016	McLean et al.	2006/0180585 A1	8/2006	Cunningham et al.
D762,418 S	8/2016	Sorensen et al.	2007/0108153 A1	5/2007	Weist
D763,076 S	8/2016	Lane et al.	2007/0199914 A1	8/2007	Hung
D764,916 S	8/2016	Mount, III et al.	2007/0251956 A1	11/2007	Wasserman et al.
D767,390 S	9/2016	Miksovsky et al.	2008/0142466 A1	6/2008	Balitski
D772,021 S	11/2016	Joy	2008/0230506 A1	9/2008	Lantz et al.
D772,652 S	11/2016	Yao	2009/0084752 A1	4/2009	Coulson
D772,718 S	11/2016	Lee	2009/0101644 A1	4/2009	Maiwald et al.
9,493,274 B2	11/2016	Ledun et al.	2010/0012615 A1	1/2010	Brooks
9,493,283 B2	11/2016	Tuyn	2010/0089151 A1	4/2010	Mantilla et al.
D773,250 S	12/2016	Miller	2010/0200602 A1	8/2010	Chan
D773,938 S	12/2016	Weber	2010/0215294 A1	8/2010	Berman
D774,826 S	12/2016	Boroski	2010/0237078 A1	9/2010	Lentz et al.
9,522,770 B2	12/2016	Pichrt	2011/0056386 A1	3/2011	Taketani
9,532,671 B2	1/2017	Lin	2011/0186585 A1	8/2011	Lu
D778,117 S	2/2017	Du	2011/0198352 A1	8/2011	Lown et al.
D778,118 S	2/2017	Du	2012/0074143 A1	3/2012	Lin
D778,725 S	2/2017	Sorensen et al.	2012/0199548 A1	8/2012	Kitto
9,586,733 B2	3/2017	Garza	2013/0136382 A1	5/2013	Barron
D784,812 S	4/2017	Miller	2013/0306642 A1	11/2013	Dabah et al.
D786,012 S	5/2017	Hein et al.	2014/0069917 A1	3/2014	Meyers et al.
D787,893 S	5/2017	Seiders et al.	2014/0251938 A1	9/2014	Rose et al.
D790,913 S	7/2017	Stover et al.	2014/0312077 A1	10/2014	Tajima et al.
D791,542 S	7/2017	Miksovsky et al.	2014/0353275 A1	12/2014	Hung
D792,765 S *	7/2017	Buck D9/449	2015/0191293 A1	7/2015	Forcella
9,694,953 B2	7/2017	Meyers et al.	2015/0251812 A1	9/2015	Gillie
9,708,108 B2	7/2017	Gregory et al.	2015/0314929 A1	11/2015	Tebbe et al.
D795,008 S	8/2017	Eyal	2015/0374151 A1	12/2015	Lin
9,745,110 B2	8/2017	Boyer et al.	2016/0159538 A1	6/2016	Michie
9,771,189 B2	9/2017	Miksovsky et al.	2016/0167852 A1	6/2016	Moradi
D799,269 S	10/2017	Vargo	2016/0176587 A1	6/2016	Heraud
D799,909 S	10/2017	Partridge	2016/0256359 A1	9/2016	Trawick et al.
D799,963 S	10/2017	Akiyama	2016/0318693 A1	11/2016	Hein et al.
9,801,969 B2	10/2017	Griffis	2016/0355305 A1	12/2016	Hoskins
D802,375 S	11/2017	Kao	2017/0001772 A1	1/2017	Rho
D802,419 S	11/2017	Seiders et al.	2017/0127859 A1	5/2017	Hornung et al.
D802,994 S	11/2017	Seiders et al.	2017/0144811 A1	5/2017	Wohlgenannt
D806,465 S	1/2018	Boroski	2017/0158398 A1	6/2017	Shively
D806,543 S	1/2018	Finkbohner et al.	2017/0158412 A1	6/2017	Seiders et al.
9,919,860 B2	3/2018	Dabah et al.	2017/0354289 A1	12/2017	Marina et al.
9,926,115 B2	3/2018	Jung et al.	2018/0029762 A1	2/2018	Eyal
D814,852 S	4/2018	Melanson et al.	2018/0050845 A1	2/2018	Chin et al.
D814,930 S	4/2018	Tremayne et al.	2018/0105346 A1	4/2018	Tolman et al.
D816,426 S	5/2018	Washburn et al.	2018/0118427 A1	5/2018	Lee et al.
D817,114 S	5/2018	Beckman	2018/0134457 A1	5/2018	Mutterle et al.
D818,775 S	5/2018	Woodruff	2018/0141722 A1	5/2018	Langelan
D819,402 S	6/2018	Silsby et al.	2018/0162608 A1	6/2018	Kim
D819,443 S *	6/2018	Martinez Carregui D9/440	2018/0162610 A1	6/2018	Kim
			2019/0002164 A1	1/2019	Nakatani et al.
			2019/0039782 A1	2/2019	Campbell

(56)

References Cited

U.S. PATENT DOCUMENTS

2019/0047754 A1 2/2019 Dubiel et al.
 2019/0047773 A1 2/2019 Bullock et al.
 2019/0062010 A1 2/2019 Apte et al.

FOREIGN PATENT DOCUMENTS

CA 3030583 A1 11/2018
 CA 3012127 A1 2/2019
 CN 201349991 Y 11/2009
 CN 301110494 1/2010
 CN 201694495 U 1/2011
 CN 202030152 U 11/2011
 CN 202060630 U 12/2011
 CN 202086330 U 12/2011
 CN 202287503 U 7/2012
 CN 103112651 A 5/2013
 CN 202981686 U 6/2013
 CN 203127394 U 8/2013
 CN 203207847 U 9/2013
 CN 103538798 A 1/2014
 CN 103619723 A 3/2014
 CN 102730301 B 3/2015
 CN 103086061 B 8/2015
 CN 303528321 12/2015
 CN 105705425 A 6/2016
 CN 303894653 10/2016
 CN 303899030 10/2016
 CN 303902404 11/2016
 CN 303905254 11/2016
 CN 303905266 11/2016
 CN 303944047 11/2016
 CN 303956194 12/2016
 CN 303965272 12/2016
 CN 303965286 12/2016
 CN 303965392 12/2016
 CN 303965400 12/2016
 CN 303966239 12/2016
 CN 303974938 12/2016
 CN 303984407 12/2016
 CN 303984493 12/2016
 CN 304011213 1/2017
 CN 304011214 1/2017
 CN 205998332 U 3/2017
 CN 108313494 A 7/2018
 CN 107224167 B 8/2018
 CN 108394633 A 8/2018
 CN 106458394 B 10/2018
 CN 105050907 B 12/2018
 CN 105358441 B 12/2018
 CN 108945789 A 12/2018
 CN 106163937 B 1/2019
 CN 105595863 B 2/2019
 CN 106255648 B 2/2019
 CN 106414269 B 2/2019
 CN 106458396 B 2/2019
 CN 109319295 A 2/2019
 CN 208470495 U 2/2019
 CN 208485029 U 2/2019
 CN 208531194 U 2/2019
 DE 2233565 A1 6/1973
 DE 2226556 B2 8/1977
 DE 3514261 A1 1/1986
 DE 29611746 U1 11/1997
 DE 69509827 T2 10/1999
 DE 29912668 U1 12/1999
 DE 102014011506 B3 7/2015
 DK 402016101176-0008 11/2016
 DK 402016101176-0010 11/2016
 EM 003528504-0004 12/2016
 EM 004539732-0003 12/2017
 EP 1693310 A1 8/2006
 EP 1934106 A1 6/2008
 EP 2457842 B1 5/2015
 EP 3066018 A4 11/2016
 EP 2851311 B1 6/2018

EP 3157833 A 8/2018
 EP 2796078 B1 10/2018
 EP 3398484 A1 11/2018
 EP 3398871 A1 11/2018
 EP 3441320 A1 2/2019
 FR 1359912 A 4/1964
 FR 2521957 B1 10/1986
 FR 2786465 6/2000
 FR 2830848 A1 4/2003
 GB 729903 A 5/1955
 GB 2114959 B 7/1985
 JP H02-052759 U 4/1990
 JP H03159974 U 7/1991
 JP H08-0117119 A 5/1996
 JP 2000333847 A 12/2000
 JP 2001315831 A 11/2001
 JP 2003125912 A 5/2003
 JP 2008162679 A 7/2008
 JP 1363566 6/2009
 JP 2010280402 A 12/2010
 JP 2011093544 A 5/2011
 JP 1530358 8/2015
 JP 2016141412 A 8/2016
 JP 6408837 B2 10/2018
 JP 6409250 B1 10/2018
 JP 2019001538 A 1/2019
 JP 6467720 B2 2/2019
 JP 2019503943 A 2/2019
 KR 200169857 Y1 2/2000
 KR 300295354 4/2002
 KR 300303813.0000 8/2002
 KR 20100008131 A 1/2010
 KR 300764889.0000 10/2014
 KR 3020150002495 12/2015
 KR 101581270 B1 1/2016
 KR 101668309 B1 10/2016
 KR 300883384.0000 11/2016
 KR 300884377.0000 12/2016
 KR 300885455.0000 12/2016
 KR 300885851.0000 12/2016
 KR 300888536.0000 1/2017
 KR 101785906 B1 10/2017
 KR 20-2019-0000204 U 1/2019
 KR 101922235 B1 2/2019
 RU 00100680 11/2016
 WO 2005028317 A2 3/2005
 WO 2006023238 A2 3/2006
 WO 07123365 A1 11/2007
 WO 08048039 A1 4/2008
 WO 14041325 A3 9/2014
 WO 14184341 A1 11/2014
 WO D088688-002 1/2016
 WO 16180908 A1 11/2016
 WO 17097485 A1 6/2017
 WO 17115193 A1 7/2017
 WO 18149763 A1 8/2018
 WO 17223093 A3 2/2019
 WO 19025589 A1 2/2019

OTHER PUBLICATIONS

Avex, "40oz. 3Sixty Pour Stainless Steel Thermal Bottle", Accessed May 18, 2017. <http://www.avexoutdoor.com/3sixty-pour-realtree-thermal-bottle.html>.

"Stanley Classic Vacuum Bottle." Found online Jul. 13, 2018 at www.amazon.com. Page dated Nov. 30, 2014. Retrieved from URL: <https://tinyurl.com/y8nnytm9> (Year: 2014).

"Thermos Stainless King 60 Ounce Vacuum Insulated Beverage Bottle." Found online Jul. 13, 2018 at www.amazon.com. Page dated Aug. 15, 2015. Retrieved from U RL: <https://www.amazon.com/Thermos-Stainless-Insulated-Beverage-Midnight/dp/B008YB4V52> (Year: 2015).

Liquid Hardware, Insulated Aqua Silver Sidewinder Vacuum Bottle 20oz./592ml. Powder Coated in USA!, product description, retrieved from Internet on Aug. 12, 2015, 3 pages. Nov. 2, 2016—(WO) International Search Report and Written Opinion—App. No. PCT/US2016/047043.

(56)

References Cited

OTHER PUBLICATIONS

Oct. 18, 2016—(JP) Office Action—APP. 2016-010799, English Translation, 3 Pages.

Oct. 18, 2016—(JP) Office Action—APP. 2016-010800, English Translation, 3 Pages.

Yeti 36 oz. Rambler: Announced Jan. 11, 2016 [online], site visited [May 10, 2016]. Available from Internet URL: <http://yeticoolers.com/rambler-bottle-36-oz/>.

KOLD Vacuum Insulated Stainless Steel Sports Bottle: Announced Dec. 8, 2015 [online], site visited [May 11, 2016]. Available from Internet URL: <http://www.amazon.com/KOLD-Sports-Water-Bottles-Insulated/dp/B018YH K79E/ref=cm>.

“Hydro Flask Insulated Stainless Steel Water Bottle” published on Dec. 29, 2014, retrieved from http://web.archive.org/web/*/https://www.amazon.com/dp/B004X55L9I/ref=twister_B00GA03LG4?_encoding=UTF8&pse=1 on Sep. 22, 2016.

“UA Beyond 18 oz. Vacuum Insulated Water Bottle” published on Mar. 29, 2015, retrieved from http://web.archive.org/web/*/https://www.underarmour.com/en-us/beyond-18-oz-vacuum-insulated-ss-bottle-with-flip-top-lid/pid1232014 on Sep. 22, 2016.

“Klean Kanteen Insulated Classic with Polypropylene” published on Jul. 7, 2015, retrieved from http://web.archive.org/web/*/https://www.lifewithoutplastic.com/store/klean-kanteen-insulated-classic-with-polypropylene-loop-cap-0-95-l-32-oz.html on Sep. 22, 2016.

“Eco Vessel 64 ounce Growler” published on Jan. 28, 2015, retrieved from http://web.archive.org/web/*/http://www.snewsnet.com/press-release/eco-vessel-launches-the-boss-insulated-growler/ on Sep. 22, 2016.

“64 oz Double-Wall Vacuum-Insulated Growler” published on Nov. 14, 2014, retrieved from https://web.archive.org/web/*/http://www.fiftyfiftybottles.com/64oz-growler/ on Sep. 22, 2016.

“2015 Boulder Insulated Water Bottle with Tea, Fruit, Ice Strainer” published on Jun. 28, 2015, retrieved from http://web.archive.org/web/*/http://www.ecovessel.com/boulder-insulated-water-bottle-with-tea-fruit-ice-strainer-20-oz/ on Sep. 22.

“KB8 20 oz. Double Wall Stainless Bottle,” published on May 22, 2015, retrieved from <https://web.archive.org/web/20150807054814/http://thermo-steel.com/work/keen-kb8> on Sep. 27, 2016.

Nov. 1, 2016—(JP) Office Action—APP. 2016-9606, English Translation, 2 Pages.

Oct. 4, 2016—(JP) Office Action—APP. 2016-9607, English Translation, 2 pages.

Oct. 4, 2016—(JP) Office Action—APP. 2016-9608, English Translation, 2 Pages.

“First Look: Yeti Rambler One Gallon ‘Jug’ Review”. Found online Jun. 12, 2017 at gearjunkie.com. Page dated May 2, 2017. Retrieved from <https://gearjunkie.com/yeti-rambler-one-gallon-jug-review>.

“Lifefactory Water Bottle with Flip Cap”. Found online Oct. 26, 2016 at amazon.com. Page dated Jan. 21, 2012. Retrieved from https://www.amazon.com/Lifefactory-22-Ounce-BPA-Free-Bottle-Silicone/dp/B01JHJYOI/ref=pd_day0_79_22?_encoding=UTF8&refRID=YW47QZQ73YFSYXXEHXG2.

“Igloo Sport Beverage Cooler”. Found online Jun. 7, 2017 at amazon.com. Page dated Mar. 9, 2013. Retrieved from https://www.amazon.com/Igloo-Beverage-Cooler-Majestic-2-Gallon/dp/B0088AYPOG/ref=cm_cr_ar_p_d_product_top?ie=UTF8.

“Klear Loop Cap Hangle Lids for Klear Bottle and Hydro Flask”. Found online Jun. 7, 2017 at amazon.com. Page dated Jul. 4, 2016. Retrieved from https://www.amazon.com/Klear-Handle-Bottle-Hydro-Flask/dp/B01EXKSRLQ/ref=cm_cr_ar_p_d_product_top?ie=UTF8. Rambler Jug Mount. Online, published date unknown. Retrieved on Jan. 2, 2018 from URL: <https://www.yeti.com/accessories/rambler-jug-mount!YRAMJM.html>.

Jan. 29, 2018—(WO) Invitation to Pay Additional Fees and Partial International Search Report—App. No. PCT/US2017/057010—13 pages.

Mar. 27, 2018—(WO) International Search Report and Written Opinion—App. No. PCT/US2017/057010—19 pages.

“Yeti Rambler Vacuum Insulated Stainless Steel One Gallon Jug with MagCap”. Found online Jun. 12, 2017 at amazon.com. Page dated May 30, 2017. Retrieved from <https://www.amazon.com/YETI-Rambler-Vacuum-Insulated-Stainless/dp/B071HTJ4Q8>.

“Klean Kanteen Stainless Unibody Bamboo Cap”. Found online Jun. 12, 2018 at amazon.com. Page dated Sep. 10, 2012. Retrieved from https://www.amazon.com/Klean-Kanteen-Stainless-Unibody-Bamboo/dp/B0083F0SDI/ref=cm_cr_ar_p_d_product_top?ie=UTF8.

“Takeya ThermoFlask”. Found online Jun. 9, 2018 at amazon.com. Page dated Apr. 15, 2016. Retrieved from https://www.amazon.com/Takeya-ThermoFlask-Pack-Back-Silver/dp/B01D7NIOWW/ref=cm_cr_ar_p_d_product_top?ie=UTF8.

“Twitter: h2go elevate and h2go inspire: same lid stlye, different body typw”. Found online Jun. 12, 2018 at twitter.com. Page dated Jan. 21, 2015. Retrieved from <https://twitter.com/etsexpress/status/557997114589196288>.

Feb. 11, 2019—(CN) Office Action—App. No. 201680059619.7.

“YETI Rambler Bottle Cup Cap Accessory.” Found online: Jun. 18, 2019 at www.amazon.com. Product reviewed May 30, 2019. Retrieved from URL: <http://tinyurl.com/y32g688u> (Year: 2019).

Jul. 15, 2019—(CN) Office Action—App. No. 201680059619.7.

* cited by examiner

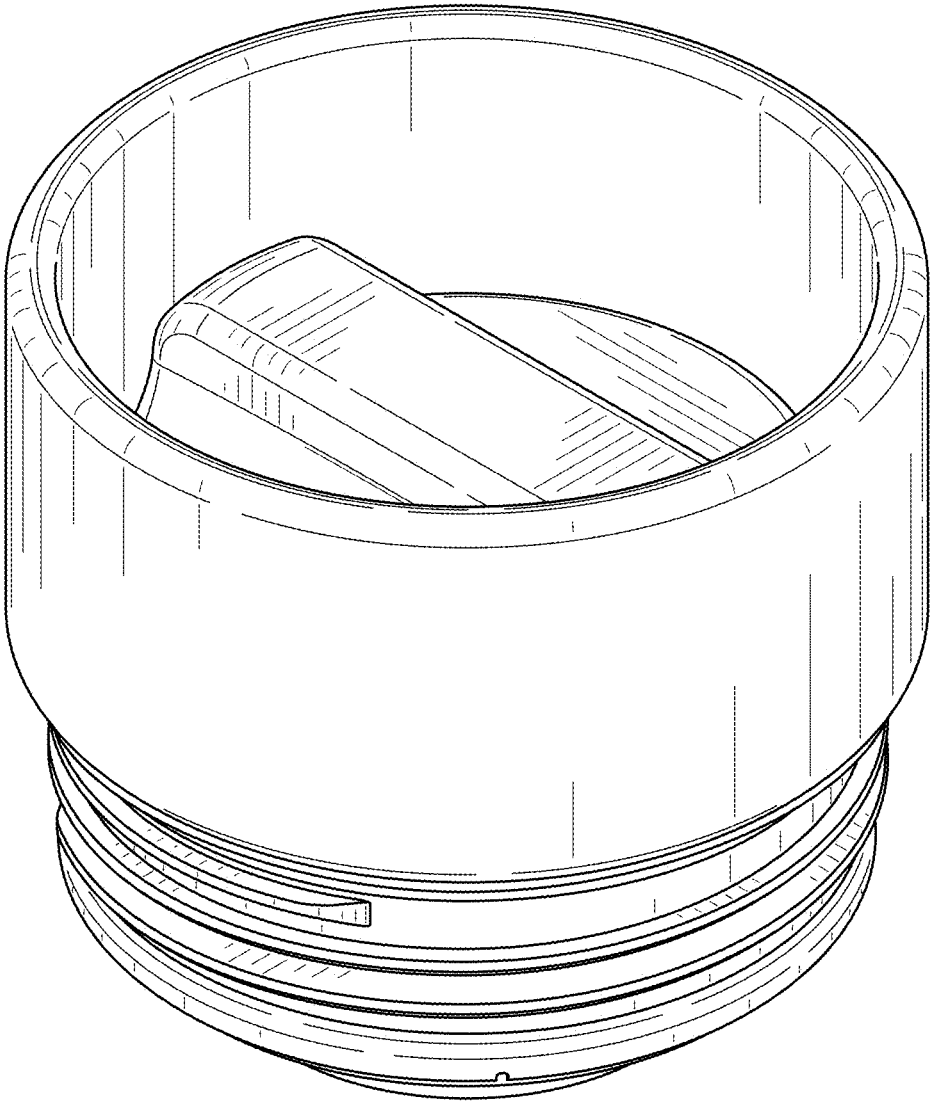

FIG. 1

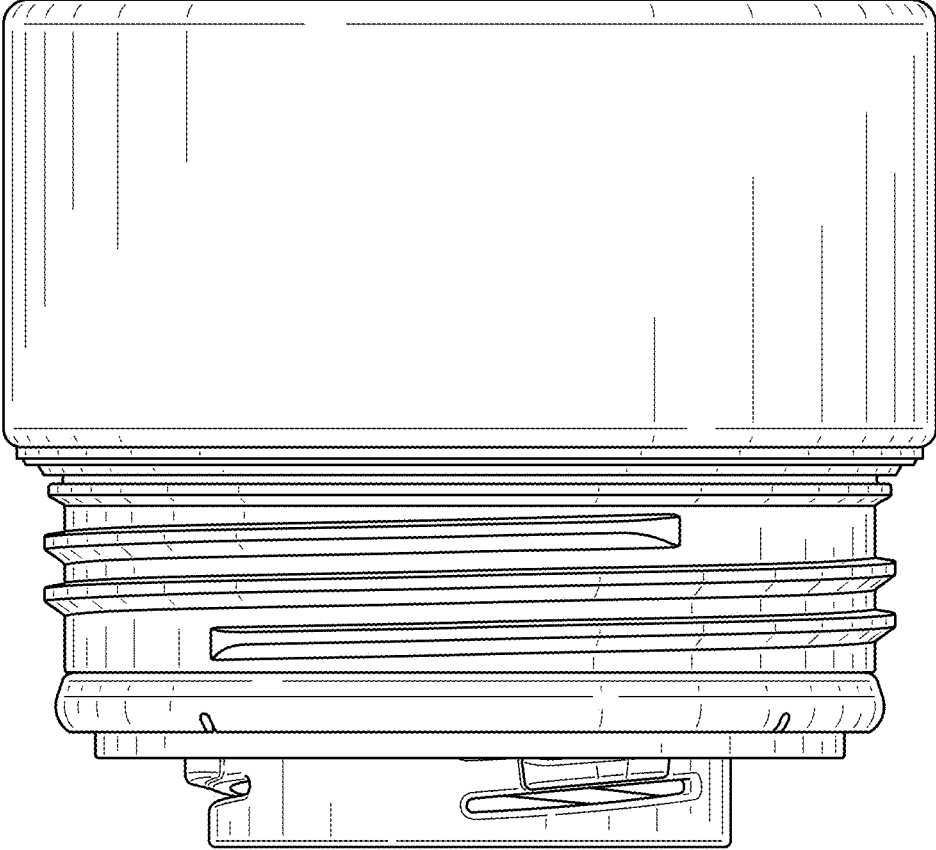

FIG. 2

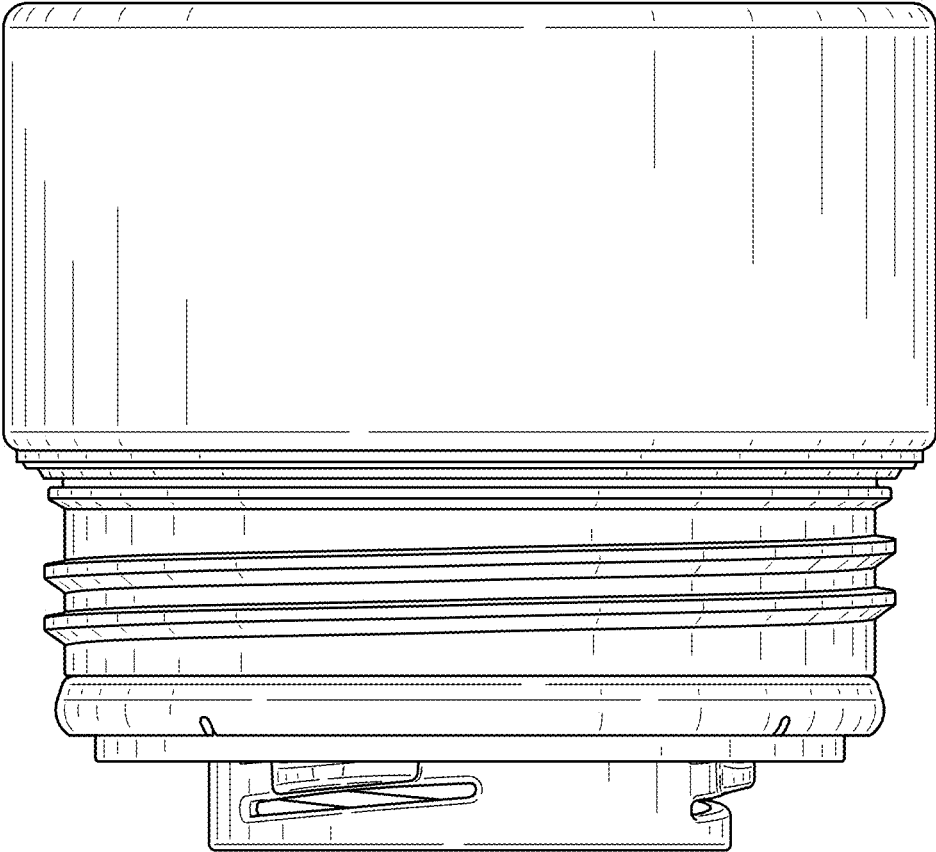

FIG. 3

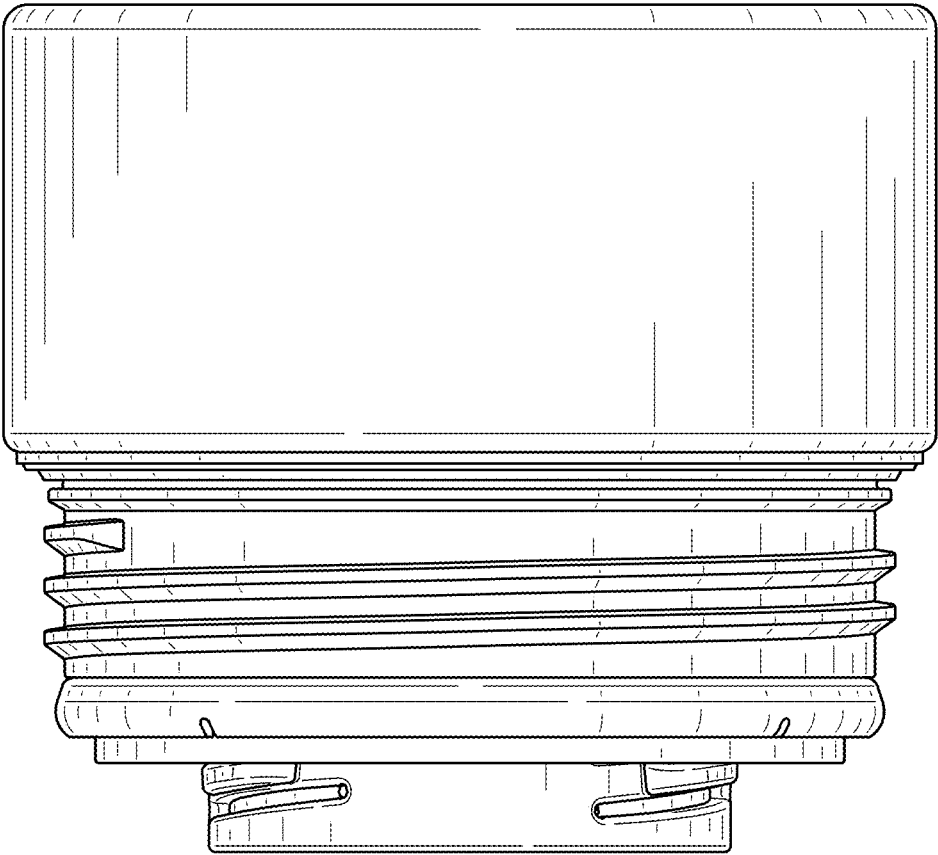

FIG. 4

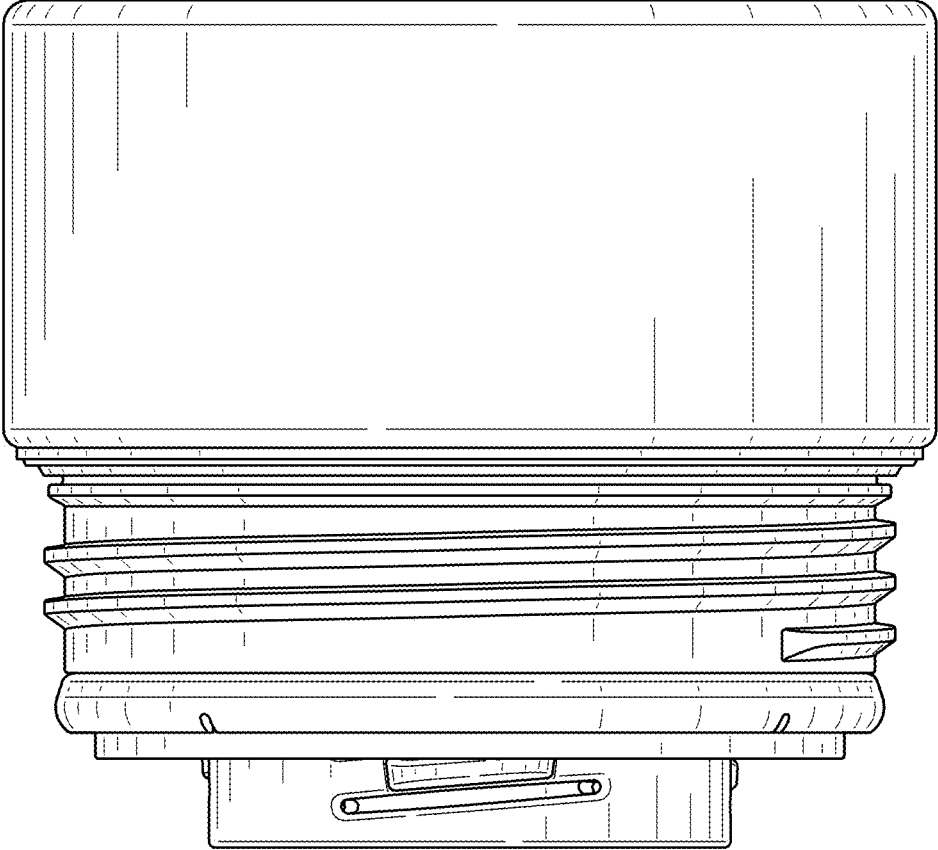

FIG. 5

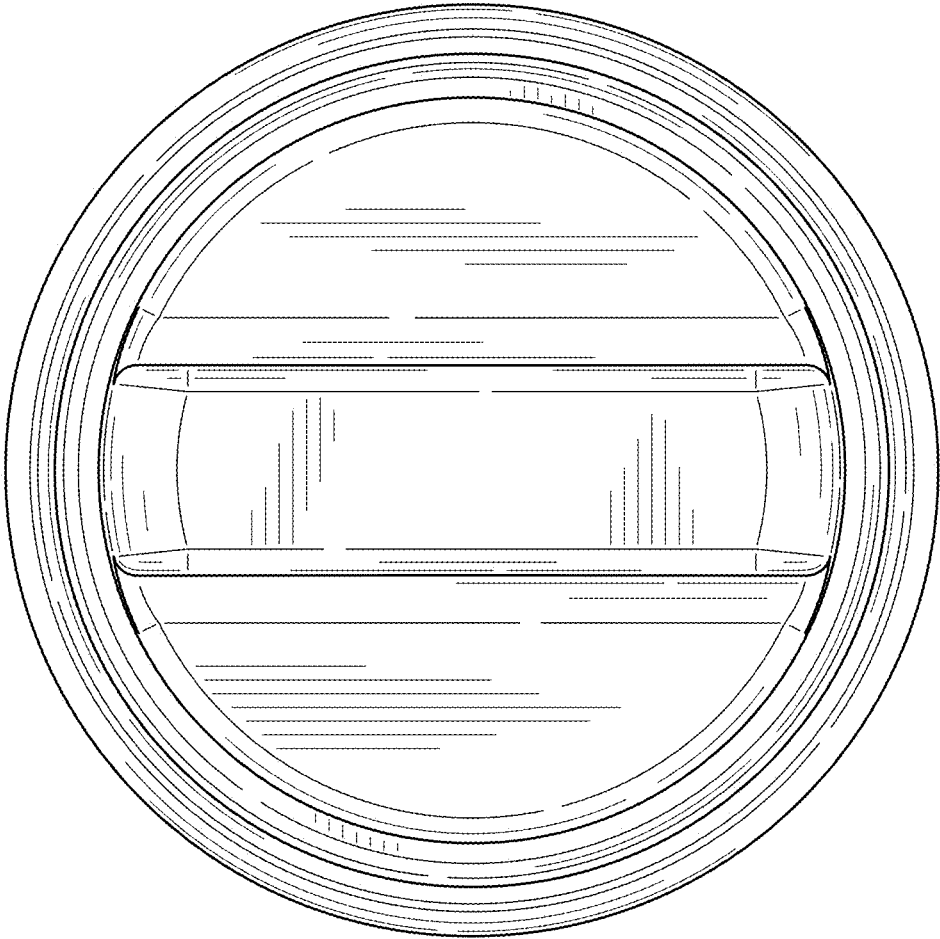

FIG. 6

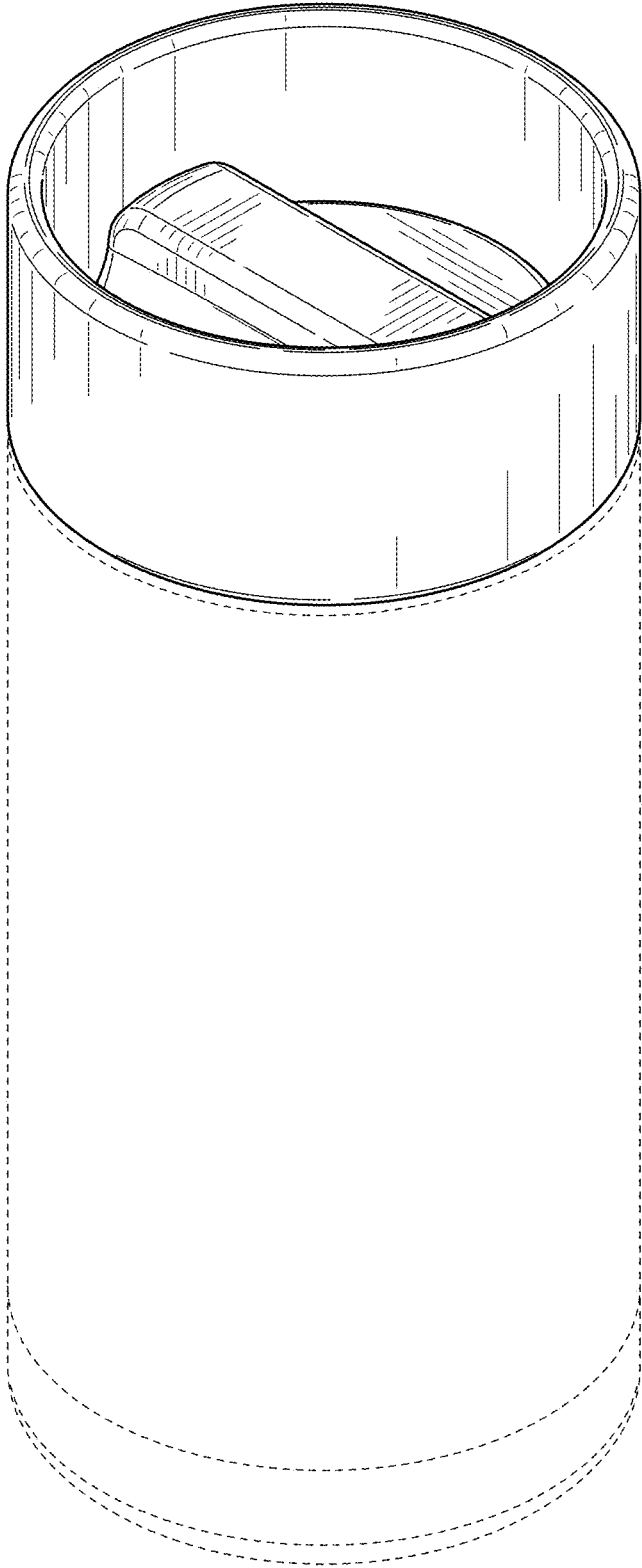

FIG. 7

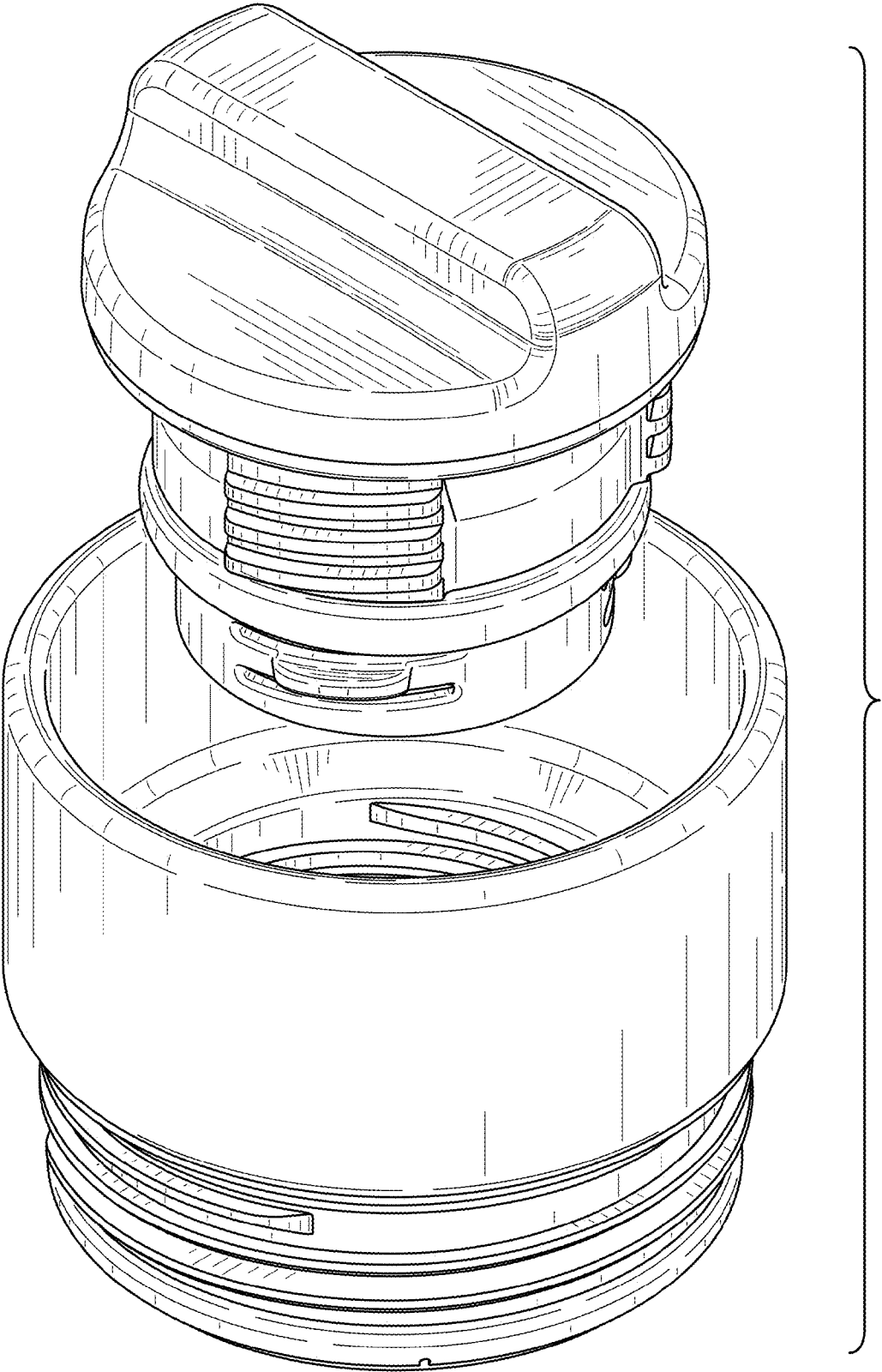

FIG. 8

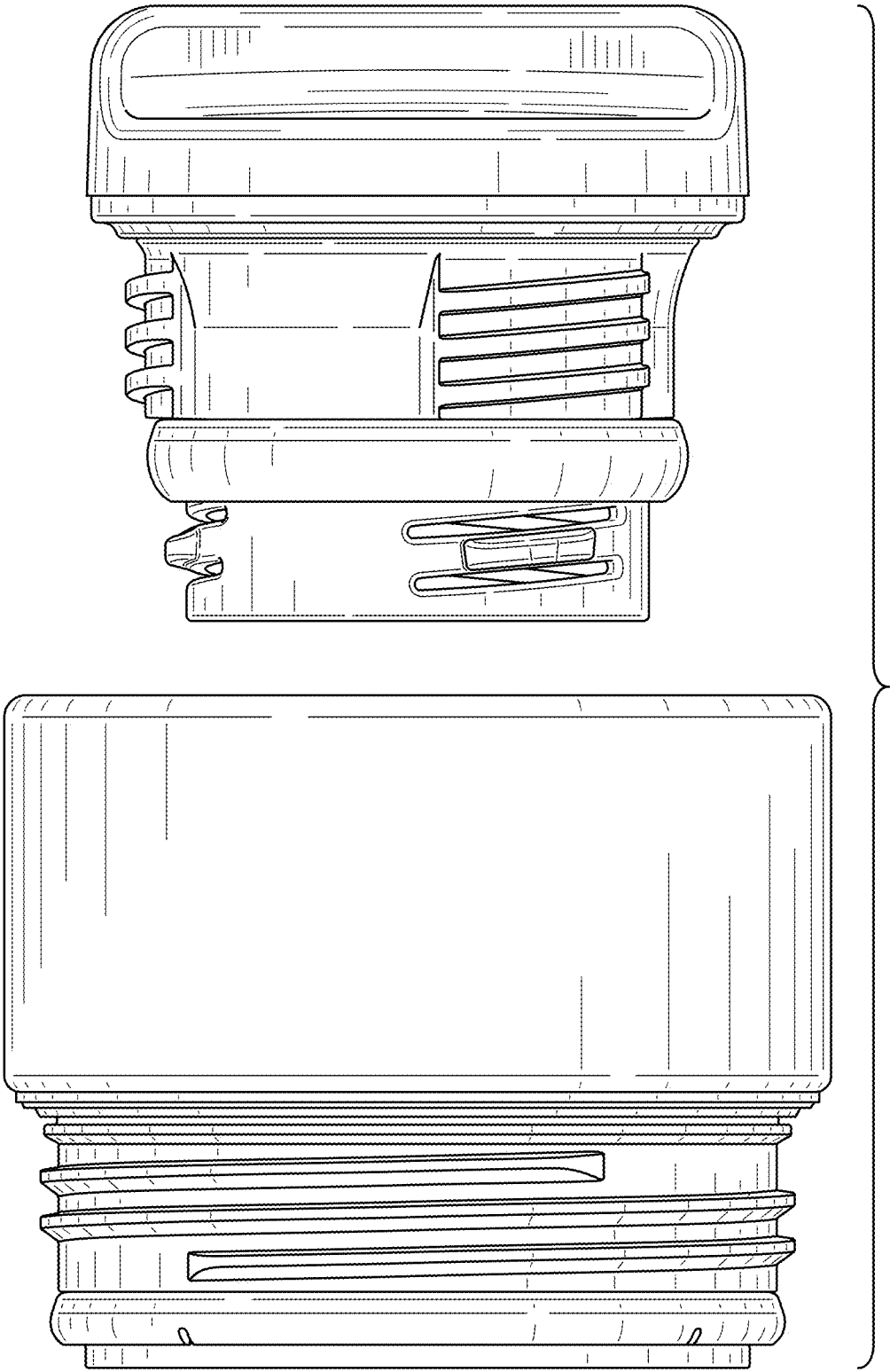

FIG. 9

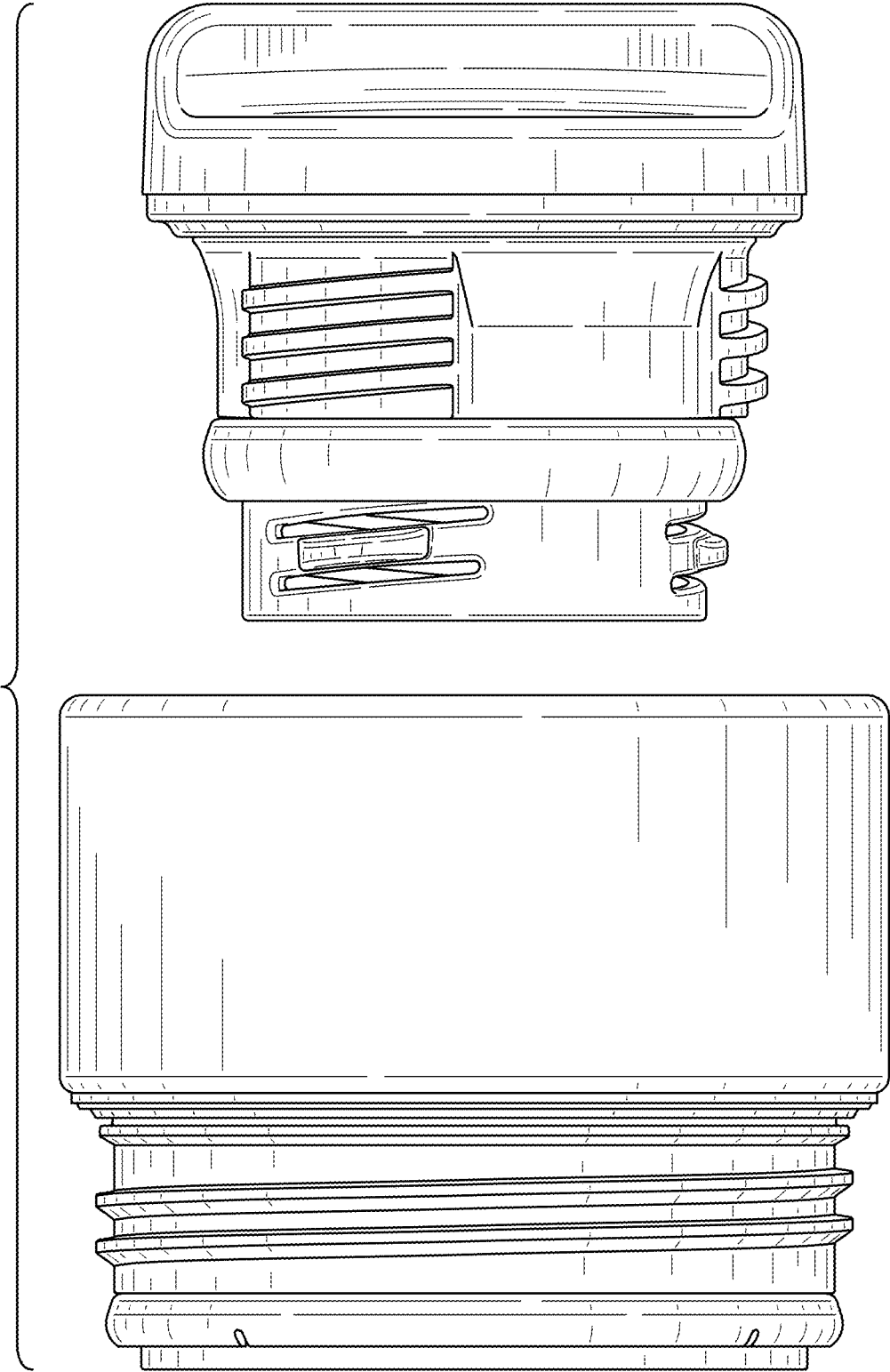

FIG. 10

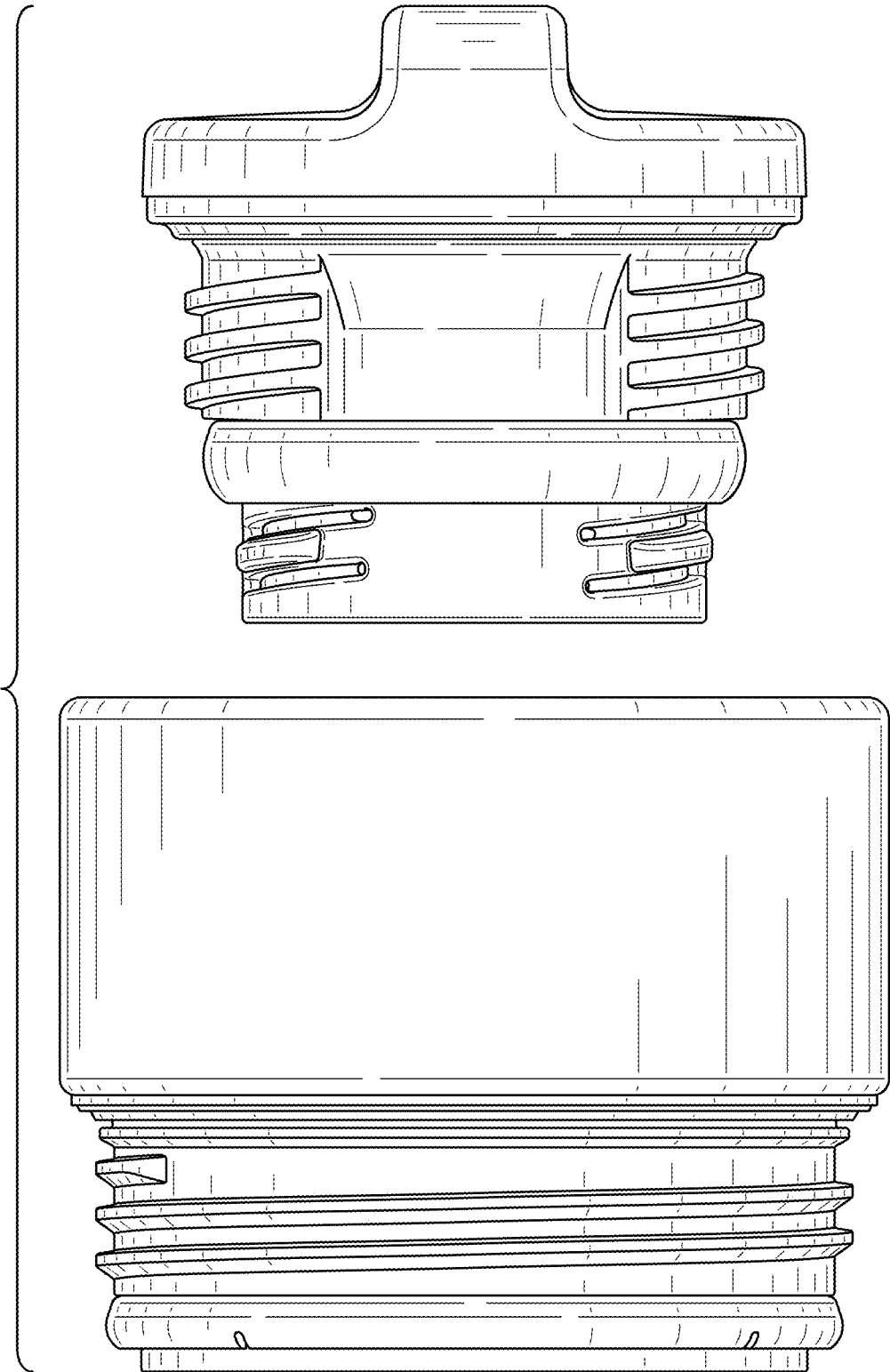

FIG. 11

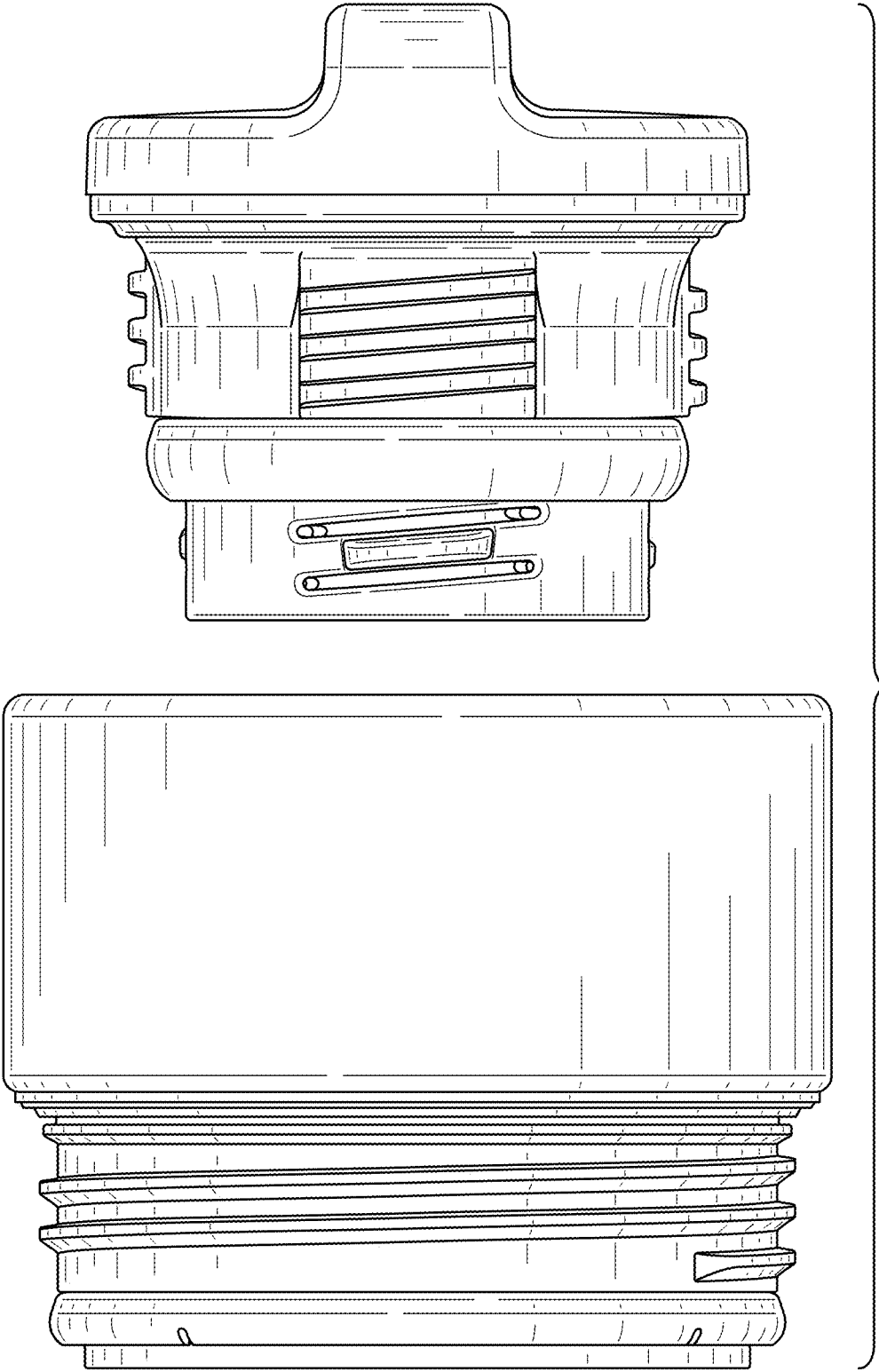

FIG. 12

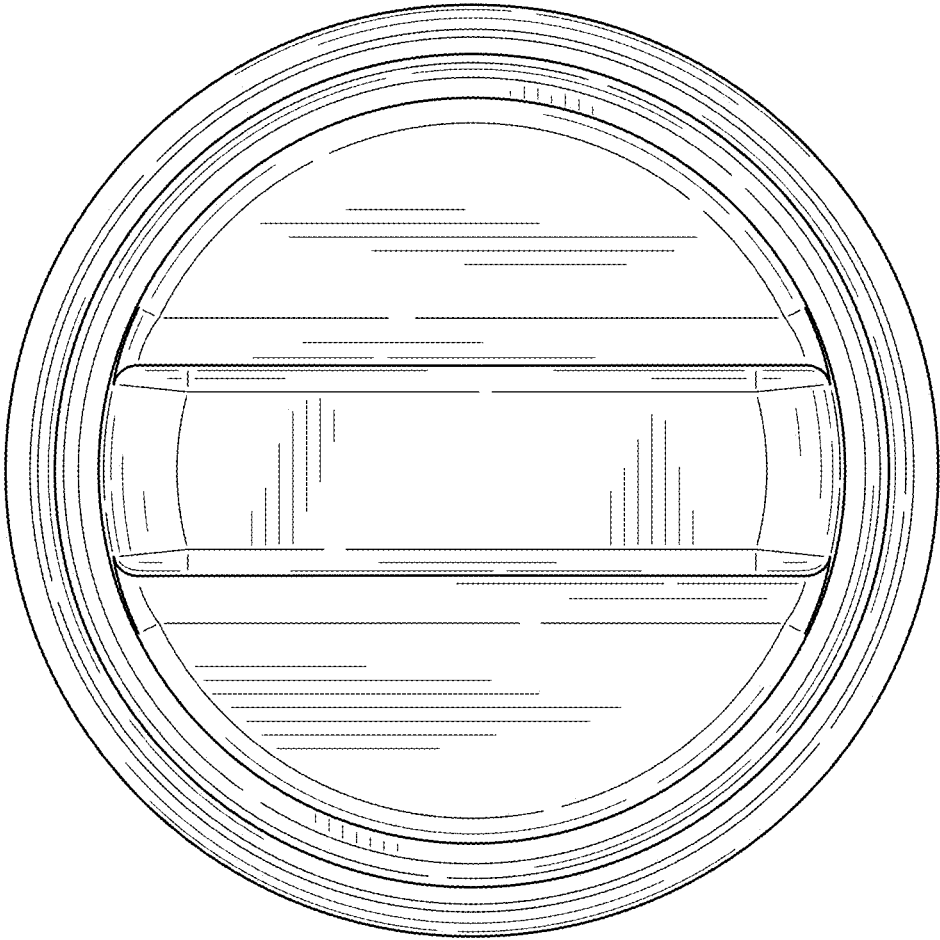

FIG. 13

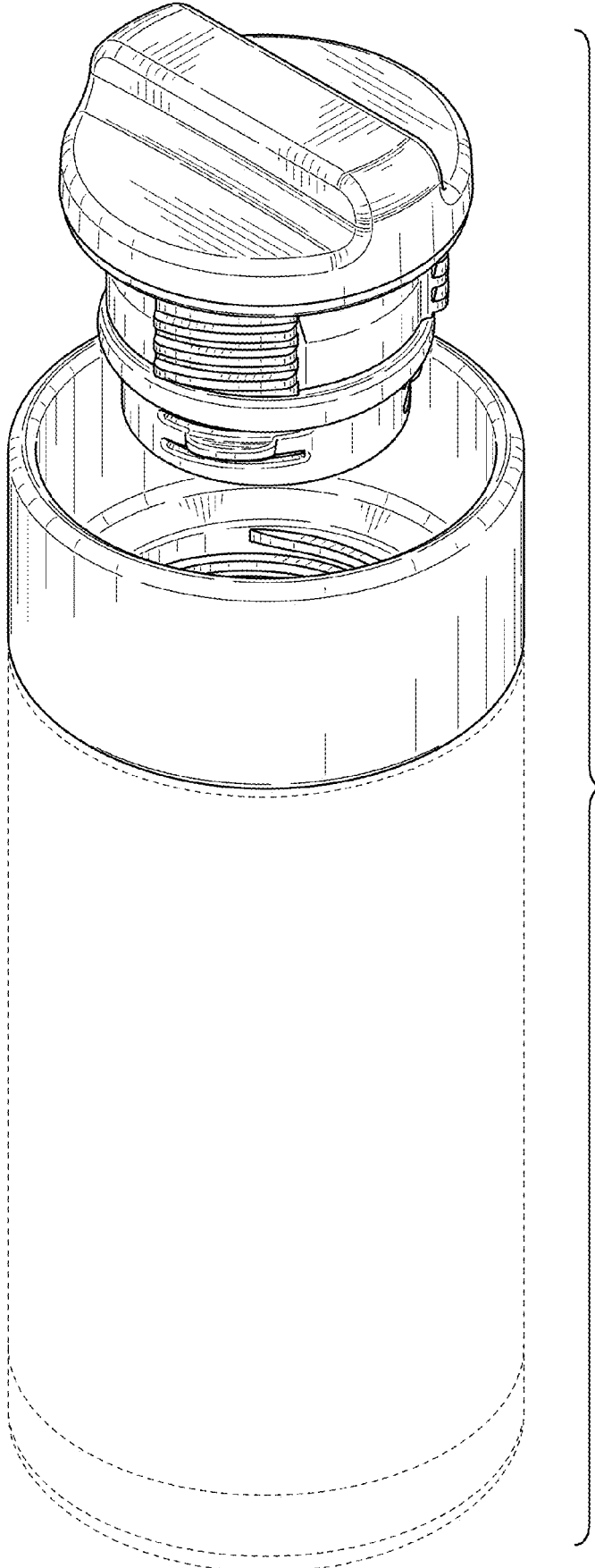

FIG. 14