

(19)  
(12)

(KR)  
(B1)

(51) 。 Int. Cl.<sup>7</sup>  
H01M 4/86

(45)  
(11)  
(24)

2004 09 07  
10-0446781  
2004 08 23

(21) 10-2002-0045070  
(22) 2002 07 30

(65)  
(43)

10-2004-0011288  
2004 02 05

(73) 20

(72) 307 303

83-3 107 103

45-1 308 2204

2 204 905

3 313 602

가 14-5LG H 324

가 14-5LG H 327

가 17 105 208

(74)  
:

(54)

가

, 1

2

5

1  
 2  
 3 4 (MEA)  
 5  
 6 7 (MEA)  
 \*\*

110 : 120 :  
 121 : 1 122 : 2  
 130 :

(BFC; Boron Fuel Cell), B (BH<sub>4</sub>)  
 가  
 가 ) , (cathode) (2 ) (anode) (  
 ( )  
 , 200 , 60 ~ 110  
 , ~ 80 , 500 ~ 700  
 , 1000  
 1 (13) (10) , ((BH<sub>4</sub>), (1  
 2) (NaBH<sub>4</sub>)) (12) (20) , (  
 13) (30) , (10)  
 (40) (10) (single cell) (11)  
 , (11) , (11)  
 (12) (13), (12) (13) 가 (12)  
 (13) (separator, bipolar plate)(14,15)  
 (11) H + , (current collector)(16,17)  
 (濕潤)  
 (12) (13)  
 , (MH)  
 (14,15) 2 (graphite)  
 Cf) 가 (12) (13) 가 (fuel channel)(  
 (Cf) , (air channel)(Co) (14,15)  
 (Co) , (10) (14,1

5) (16,17) (Cf) (10) (Co) .

21 , 22 , 23 , 31 , 32 , M

(14,15) (Cf) B (Co) 가 ( ,anode)(12) ( ,cathode)(13) , 가

$BH_4^- + 8OH^- \rightarrow BO_2^- + 6H_2O + 8e^-$  (12) (11) /

$2O_2 + 4H_2O + 8e^- \rightarrow 8OH^-$  (13) ( ) (12) (13) , (16,17)

(10) (16,17) , 2 4 (12)

(10) 가 , BFC

가가 BFC

가

(BH<sub>4</sub>) 가

2 , 1 ,

5 , 6 7 (MEA)

(110) H<sup>+</sup> 2 (110) (121)(122) (120) (130)

(120) (120) 1 (121) 2 (122)

1 (121) BH<sub>4</sub> (122) 1 (121)

1 (121) 2 (122) ( BH<sub>4</sub>) (140)

(Cf) , 1 (121) 2 (122)

1 (121) 2 (122) 1 (121) 가 2 ( )

(122) (121)(122) (

140)



1 2

(57)

1.

가

Z

2.

1 ,

3.  
2 ,

4.  
1 3 ,

5.  
BH<sub>4</sub>) 가 (

1 , 2

6.  
5 1 2

7.  
5 1 6 2

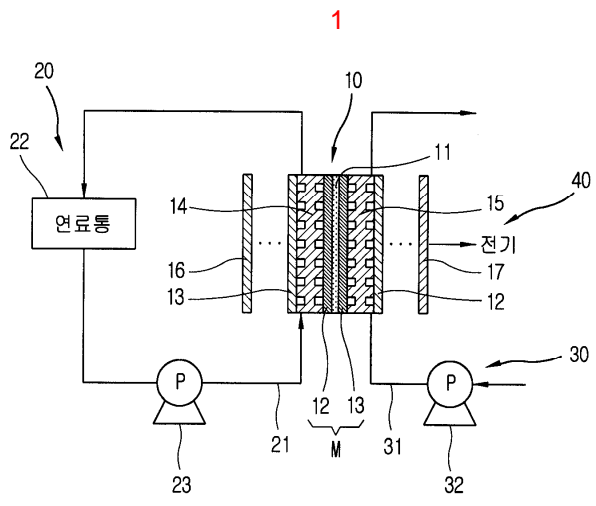

2

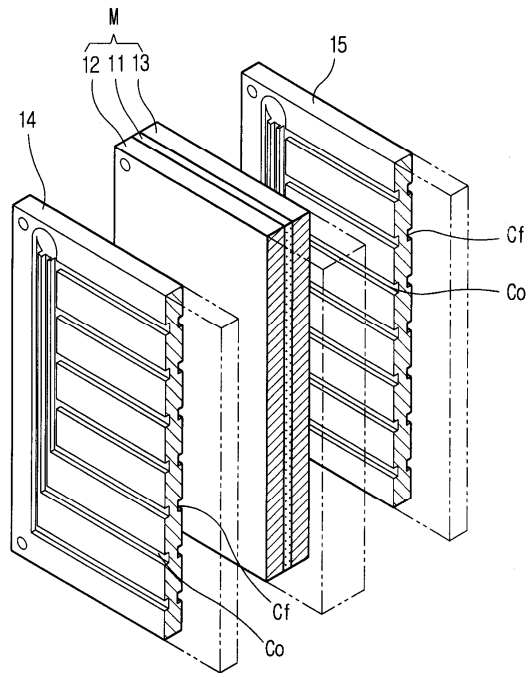

3

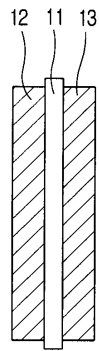

4

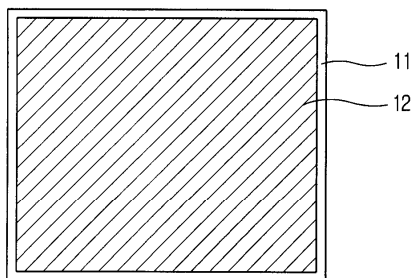

5

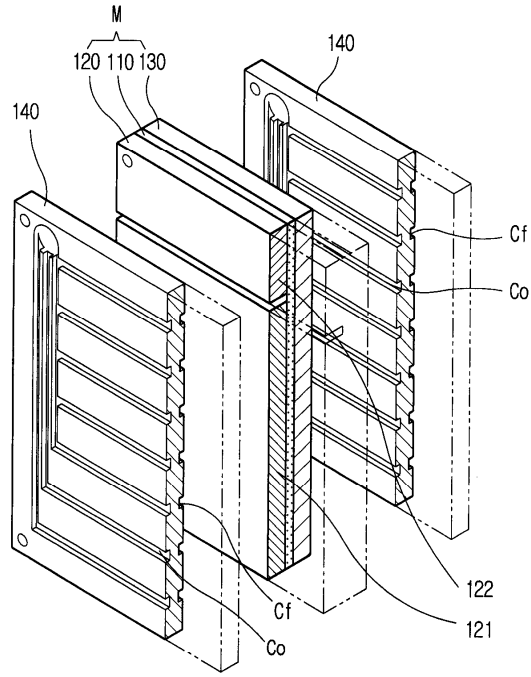

6

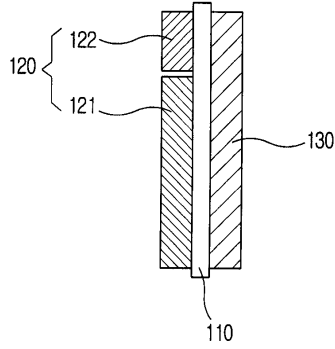

7

