

(12) **UK Patent Application** (19) **GB** (11) **2 330 867** (13) **A**

(43) Date of A Publication 05.05.1999

(21) Application No 9824031.0
(22) Date of Filing 03.11.1998
(30) Priority Data
(31) 08962744 (32) 03.11.1997 (33) US

(71) Applicant(s)
National Molding Corporation
(Incorporated in USA - New York)
5 Dubon Court, Farmingdale, New York 11735-1065,
United States of America

(72) Inventor(s)
Joseph Anscher

(74) Agent and/or Address for Service
Bout Wade Tennant
27 Furnival Street, LONDON, EC4A 1PQ,
United Kingdom

(51) INT CL⁶
F16G 11/10

(52) UK CL (Edition Q.)
E2A AGKD A370 A374 A376 A416

(56) Documents Cited
GB 1247781 A GB 1164345 A US 5469583 A
US 4639978 A US 4373234 A

(58) Field of Search
UK CL (Edition P) E2A AGH AGKD AGKFC
INT CL⁶ A44B 11/12, F16G 11/10

(54) Abstract Title
Cord fastener

(57) A fastener for selectively clamping a zipper cord which includes a base portion 2 having a U-shaped channel therein and a movable locking arm 8 selectively movable from an unlocked to a locked position. The locking arm is provided with a securing protrusion 9 for securing a zipper cord disposed in the U-shaped channel and is sized and adapted so that the locking arm is urged or biased into the locked position as the zipper cord is pulled away from the base portion. Means (eg 16,17) interengage to hold the arm in the locked position.

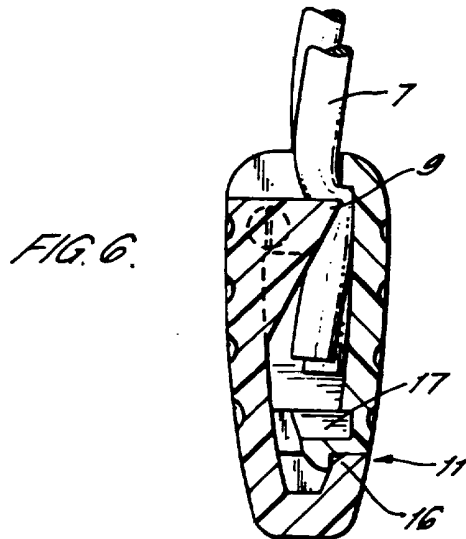
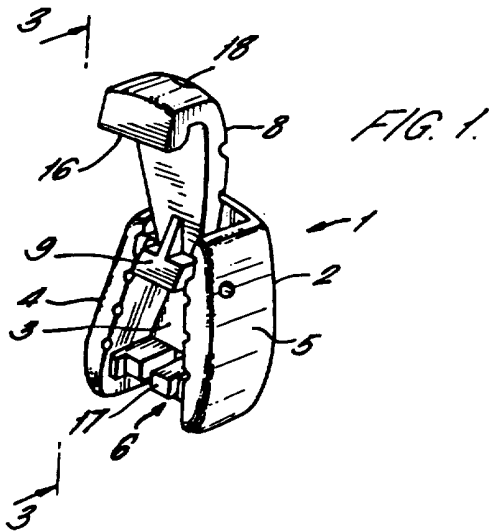

GB 2 330 867 A

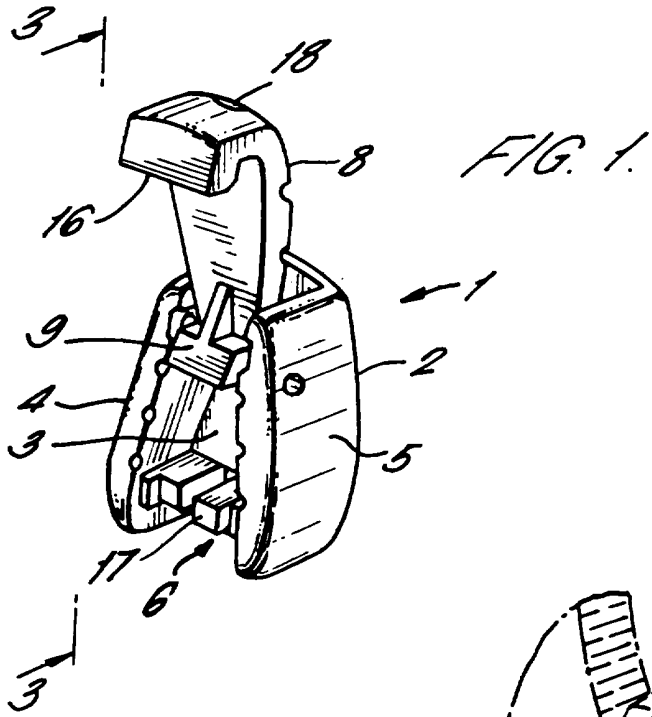

FIG. 2

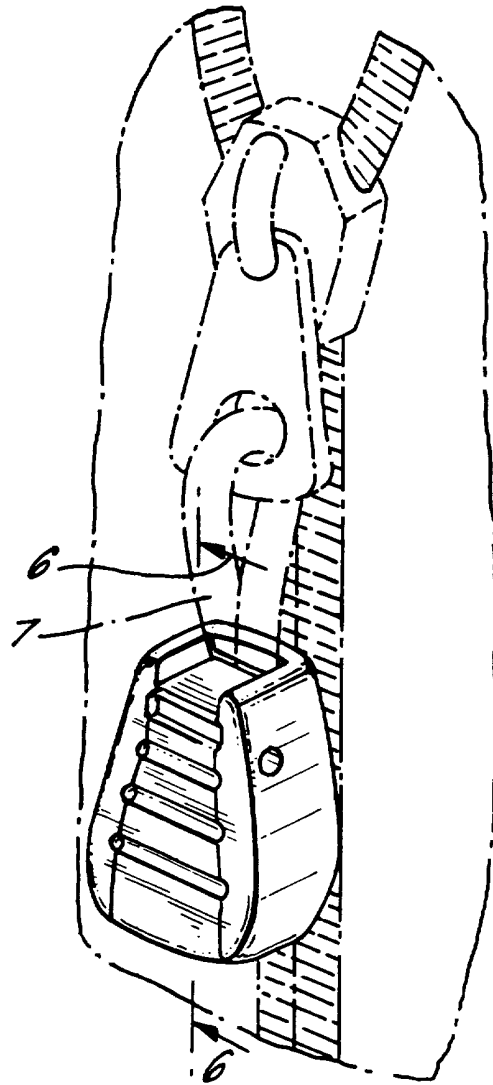

FIG. 3.

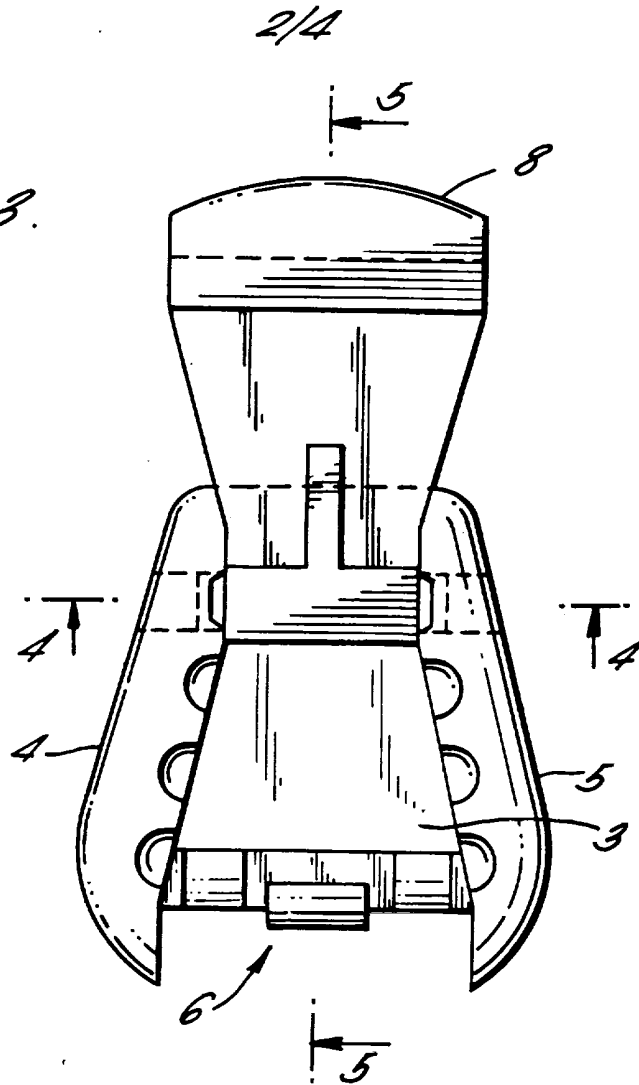
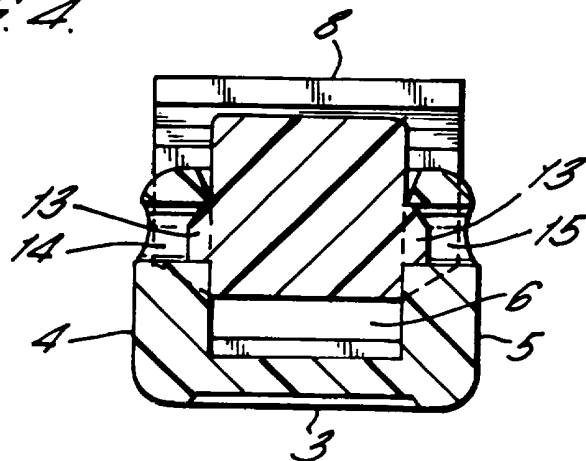

FIG. 4.



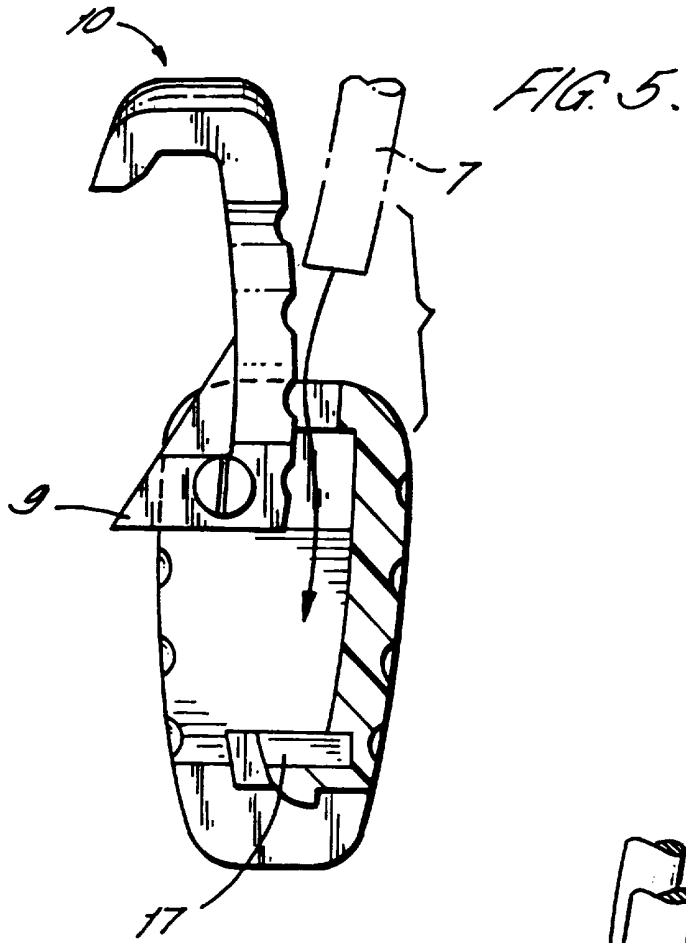

FIG. 5.

FIG. 6.

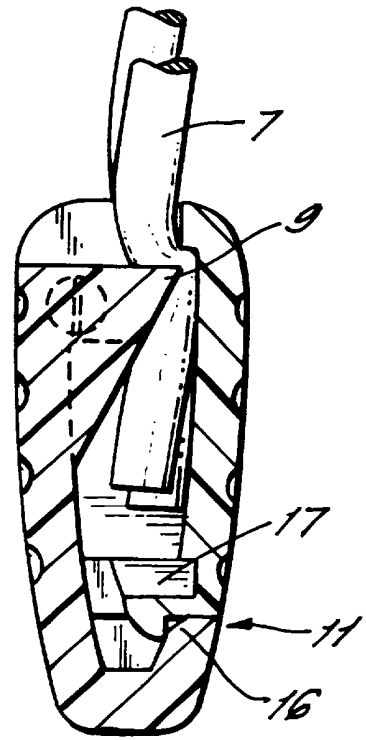

FIG. 5A.

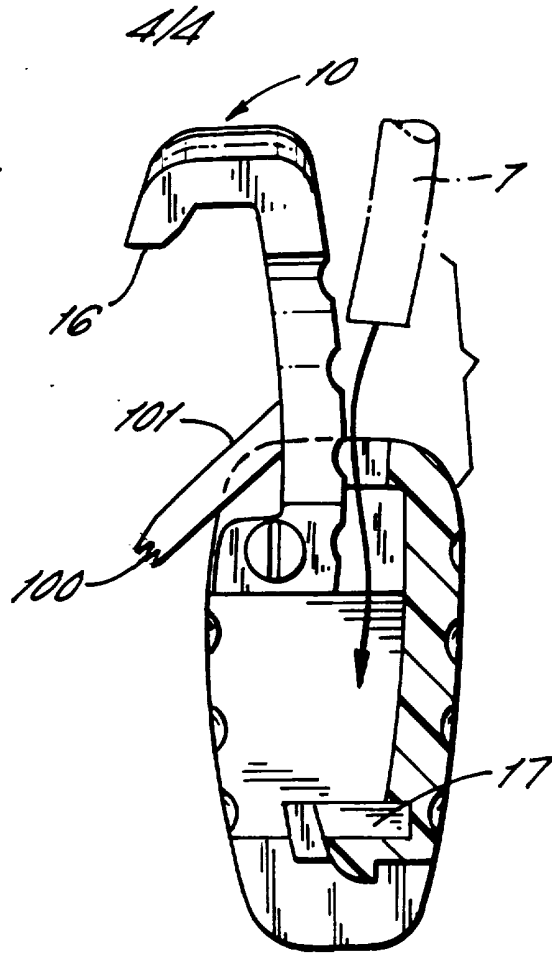

FIG. 7.

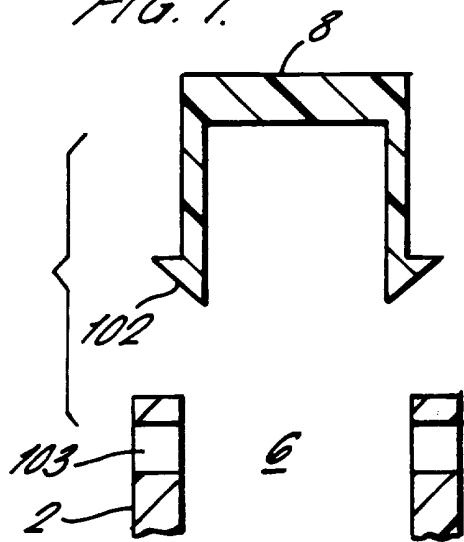
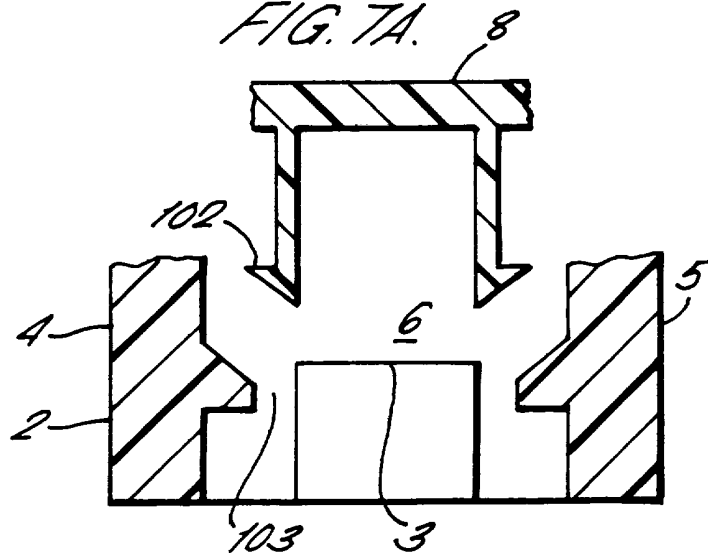

FIG. 7A.



ZIPPER PULL CORD FASTENER

5

The present invention relates generally to a device for selectively securing a cord, rope, or other elongated flexible article and more particularly to a device for selectively securing and attaching a zipper pull.

10

Various clamps are known in the prior art. For instance, U.S. Patent 4,368,999 discloses a coupling for connecting the end part of a flexible element such as a cable or wire. The part is formed from two separate portions. The first portion is a cage receiving the flexible element and includes laterally at least one extending flexible strip normally projecting outside of the cage. A second portion is a slider being adapted to be slid over the cage in order to urge the strip inwardly so that a portion of the strip is embedded in the flexible element.

15

20

U.S. Patent 5,283,930 discloses a clasp for a folded cord includes two portions which make to form a clasp body thereby capturing the folded cord therebetween. The portions include gripping teeth for defining a tortious path for the cord.

25

U.S. patent 4,688,337 discloses a two piece buckle type fastener including a receptacle and clasp. The clasp includes a base, a substantially rigid stem protruding from the base, a pair of resilient arms extending from the stem, and locking means on the arms. The receptacle includes a body that defines a cavity adapted to receive and to cooperatively engage the pair of resilient arms within the cavity. The fastener also includes means for disengaging the locking means so that the receptacle and clasp can be separated.

U.S. patent 5,469,583 discloses a buckle device for temporarily fastening at least two straps together having a base unit and an arm rotatably mounted on the base unit. The arm has a strap engagement part with a protuberance thereon, the arm being movable from a locked position to an open position, the arm in its locked position forcing at least two straps in engagement with each other between the engagement part and the base unit. The arm is movable to an open position wherein the engagement part is rotated away from the straps so that the straps are free to move relative to each other and relative to the device.

U.S. Des. 355,147 discloses a zipper pull.

One shortcoming of these prior art securing devices is that they may be complicated and, thus, expensive to manufacture.

Another shortcoming of these prior art devices is that it may be difficult or time consuming to introduce and remove the cord or rope from the securing device.

Yet another shortcoming of prior art devices is that the portions securing the cord or rope may tend to open or loosen in response to the cord or rope being pulled in a direction away from the housing.

It is an object of this invention to provide an apparatus for easily and quickly securing a rope or cord to a zipper that is simple and inexpensive to manufacture.

It is another object of this invention to provide an apparatus for securing a rope or cord to a zipper that urges the locking portions into a locking position in response to a pull or tug or other tension applied to the rope or cord.

It is another object of this invention to provide a device for selectively securing an elongated flexible article to a zipper, comprising: a device for selectively securing a zipper cord, comprising: a base portion having a base portion wall, a first side wall projecting from the base portion wall and a second side wall projecting from the base portion wall, the walls defining a U-shaped channel; and a locking arm rotatably mounted on the base portion, the locking arm provided with a

locking arm engagement protrusion, the locking arm rotatably
movable from an unlocked first position which provides a first
clearance between the base portion wall and the locking arm
engagement protrusion, the first clearance sufficient for the
5 zipper cord to be introduced into and withdrawn from the U-
shaped channel, the locking arm rotatable to a locked second
position providing a second clearance between the base portion
wall and the locking arm engagement protrusion, the second
clearance smaller than the first clearance and sized so that
10 when the locking arm is in the second position, the locking arm
engagement protrusion impinges on the zipper cord in an amount
sufficient to secure the zipper cord in the U-shaped channel,
the locking arm engagement protrusion sized and disposed so that
when the zipper cord is pulled in a direction away from the base
15 portion, the locking arm is urged toward the second position;
means for selectively moving the locking arm from the first
position to the second position; and means for locking the
locking arm in the second position.

It is yet another object of this invention to provide a
20 device for selectively securing a zipper cord, comprising a base
portion having a base portion wall, a first side wall projecting
from the base portion wall and a second side wall projecting
from the base portion wall, the walls defining a U-shaped
channel; and a locking arm rotatably mounted on the base

portion, the locking arm provided with a flexible tooth-like member, the locking arm rotatably movable from an unlocked first position which provides a first clearance between the base portion wall and the flexible tooth-like member, the first clearance sufficient for the zipper cord to be introduced into and withdrawn from the U-shaped channel, the locking arm rotatable to a locked second position providing a second clearance between the base portion wall and the flexible tooth-like member, the second clearance smaller than the first clearance and sized so that when the locking arm is in the second position, the flexible tooth-like member, impinges on the zipper cord in an amount sufficient to secure the zipper cord in said U-shaped channel, the flexible tooth-like member sized and adapted to accommodate and secure cords of varying diameters when the locking arm is disposed in the second position, the flexible tooth-like member sized and disposed so that when the zipper cord is pulled in a direction away from the base portion, the rotatable arm is urged toward the second position; means for selectively moving the locking arm from the first position to the second position; and means for locking the locking arm in the second position.

FIG. 1 shows a locking arm and base portion constructed in accordance with the invention with the locking arm in a first or unlocked position;

5 FIG. 2 is the device of FIG. 1 with the locking arm disposed in the second or locked position;

FIG. 3 is a side view of the device shown in FIG. 1;

FIG. 4 is a cross-sectional end view taken along line 4-4 of FIG. 3;

10 FIG. 5 is a cross-sectional side view taken along line 5-5 of FIG. 3 with the locking arm in the first or unlocked position;

FIG. 5A shows an alternative embodiment of the invention utilizing a flexible tooth-like member;

15 FIG. 6 shows the device shown in FIG. 5 with the locking arm moved to the second or locking position;

FIG. 7 shows an alternative embodiment of a locking means utilized in accordance with the invention; and

20 FIG. 7A shows an alternative embodiment of a locking means utilized in accordance with the invention.

25 FIG. 1 shows a zipper cord fastener 1 constructed in accordance with the present invention and shows a base portion 2

having a base portion wall 3, a first side wall 4 projecting from the base portion wall 3, and a second side wall 5 projecting from the base portion wall 3, defining a U-shaped channel 6. The U-shaped channel 6 is sized to receive an elongated flexible article such as a zipper cord 7, (shown in FIGS. 2, 5 and 6).

A locking arm is 8 rotatably mounted on the base portion 2 and is provided with a locking arm engagement protrusion 9. The locking arm 8 is rotatably movable from an unlocked first position 10 as shown in FIG. 5 to a locked second position 11 as shown in FIG. 6. Means are provided for selectively rotatably moving the locking arm 8 from the first or unlocked position 10 to the second or locked position 11. In one preferred embodiment, as shown in FIG. 4, the means for moving the locking arm 8 from the first position 10 to the second position 11 comprises a pair of cylindrical protrusions 12 and 13 extending from the locking arm 8 for close fitting engagement with a similarly shaped corresponding pair of depressions or apertures 14 and 15 disposed in the side walls 4 and 5. The outward ends of protrusions 12 and 13 may be cammed, as shown in FIG. 4, to facilitate a "snap-fit" engagement of protrusions 12 and 13 with depressions 14 and 15 and, thus, facilitate assembly.

When the locking arm 8 is disposed in the first position 10 it provides a first clearance C1 between the base portion wall 3 and the locking arm engagement protrusion 9. This first clearance C1 is sufficient to permit a zipper cord 7 or other elongated flexible article to be introduced into and withdrawn from the U-shaped channel 6. When the locking arm 8 is rotated and moved to the second or locking position 11 it provides a second clearance C2 between base portion wall 3 and the locking arm engagement protrusion 9. The second clearance C2 is smaller than the first clearance C1 which causes the locking arm engagement protrusion 9 to impinge upon a zipper cord, rope or wire 7 disposed in the U-shaped channel 6 in an amount sufficient to secure the zipper cord, rope or wire 7 in the U-shaped channel 6 of the base portion 2. The locking arm engagement protrusion 9 is sized and disposed so that when the rope, zipper cord or wire 7 is pulled or tugged in a direction away from the base portion 2, the pressure applied to the locking arm engagement protrusion 9 causes the locking arm 8 to be urged toward the second or locked position 11. Thus, the harder the cord or wire 7 is pulled, the tighter it is secured within the U-shaped channel 6 of the base 2.

In an alternative embodiment, shown in FIG. 5A the locking arm 8 is provided with a flexible tooth-like member 101 that is sufficiently flexible so as to accommodate cords of

varying diameters and is sufficiently rigid to secure cords of varying diameters in the channel 6 when the locking arm is in the second or locked position. The flexible tooth-like member 101 may be provided with serrations 100.

5 In a preferred embodiment, the device 1 is provided with a locking means for selectively locking the locking arm in the second or locked position 11. A variety of locking means well known to those skilled in the art as suitable for this purpose may be utilized, however, in a preferred embodiment a 10 male female interlock is used. In one preferred embodiment, shown in FIGS. 5 and 6, the locking arm 8 is provided with a first interlock protrusion 16 sized and adapted to selectively engage and disengage a second interlock protrusion 17 protruding from the base portion wall 3. In an especially preferred 15 embodiment, the locking arm 8 is provided with a fingernail tab 18 for grasping the locking arm 8, thus, facilitating the selective movement of the locking arm 8 from the second or locked position 11 to the first or unlocked position 10.

20 In yet another preferred embodiment of a locking means, shown in FIG. 7, the locking means comprises at least one interlock protrusion 102 extending from the locking arm. The base is provided with at least one corresponding interlock receiving aperture 103 sized and adapted to receive and interlock with the interlock protrusion 102 when the locking arm

is disposed in the second or locked position 11. The at least one corresponding receiving aperture 103 may be disposed in one or both of the first and second base portion side walls 4 and 5 as shown in FIG. 7. Alternatively, the at least one
5 corresponding receiving aperture 103 may be disposed in the base portion wall 3 as shown in FIG. 7A.

Although the present invention has been described in specific and detailed terms with respect to the preferred
10 embodiments as set forth above, various other embodiments of this invention including alterations in size, shape, etc., substitutions of conventional elements and other applications will be readily apparent to those with ordinary skill in the art without departing from the broader spirit and scope of the invention as set forth in the appended claims. Therefore, the
15 specification is to be regarded in an illustrative rather than restrictive sense.

WHAT IS CLAIMED IS:

1. A device for selectively securing a zipper cord, comprising:

a) a base portion having a base portion wall, a first side wall projecting from said base portion wall and a second side wall projecting from said base portion wall, said walls defining a U-shaped channel; and

b) a locking arm rotatably mounted on said base portion, said locking arm provided with a locking arm engagement protrusion, said locking arm rotatably movable from an unlocked first position which provides a first clearance between said base portion wall and said locking arm engagement protrusion, said first clearance sufficient for said zipper cord to be introduced into and withdrawn from said U-shaped channel, said locking arm rotatable to a locked second position providing a second clearance between said base portion wall and said locking arm engagement protrusion, said second clearance smaller than said first clearance and sized so that when said locking arm is in said second position, said locking arm engagement protrusion impinges on said zipper cord in an amount sufficient to secure said zipper cord in said U-shaped channel, said locking arm engagement protrusion sized and disposed so that when said zipper cord is pulled in a direction away from said base portion, said locking arm is urged toward said second position;

c) means for selectively moving said locking arm from said first position to said second position; and

d) means for locking said locking arm in said second position.

2. The device of claim 1, wherein said means for selectively moving comprises a plurality of protrusions extending from said locking arm sized and adapted to selectively engage corresponding apertures disposed in said side walls.

3. The device of claim 1, wherein said locking means comprises an interlock protrusion extending from said locking arm sized and adapted to selectively engage and interlock with a corresponding interlock protrusion extending from said base portion wall.

4. The device of claim 1, wherein said locking means comprises at least one interlock protrusion protruding from said locking arm and at least one interlock receiving aperture disposed in said base, said interlock protrusion and said interlock receiving aperture sized and adapted to interlock when said locking arm is disposed in said second position.

5. The device of claim 4, wherein said at least one interlock receiving aperture is disposed in at least one of said first and second sidewalls of said base portion.

6. The device of claim 4, wherein said at least one interlock receiving aperture is disposed in said base portion wall of said base portion.

7. A device for selectively securing a zipper cord, comprising:

a) a base portion having a base portion wall, a first side wall projecting from said base portion wall and a second side wall projecting from said base portion wall, said walls defining a U-shaped channel; and

b) a locking arm rotatably mounted on said base portion, said locking arm provided with a flexible tooth-like member, said locking arm rotatably movable from an unlocked first position which provides a first clearance between said base portion wall and said flexible tooth-like member, said first clearance sufficient for said zipper cord to be introduced into and withdrawn from said U-shaped channel, said locking arm rotatable to a locked second position providing a second clearance between said base portion wall and said flexible tooth-like member, said second clearance smaller than said first

clearance and sized so that when said locking arm is in said second position, said flexible tooth-like member impinges on said zipper cord in an amount sufficient to secure said zipper cord in said U-shaped channel, said flexible tooth-like member sized and adapted to accommodate and secure cords of varying diameters when said locking arm is disposed in said second position, said flexible tooth-like member sized and disposed so that when said zipper cord is pulled in a direction away from said base portion, said locking arm is urged toward said second position;

c) means for selectively moving said locking arm from said first position to said second position; and

d) means for locking said locking arm in said second position.

8. The device of claim 7, wherein said means for selectively moving comprises a plurality of protrusions extending from said locking arm sized and adapted to selectively engage corresponding apertures disposed in said base portion.

9. The device of claim 7, wherein said locking means comprises an interlock protrusion extending from said locking arm sized and adapted to selectively engage and interlock with a

corresponding interlock protrusion extending from said base portion wall.

10. The device of claim 7, wherein said locking means comprise at least one interlock protrusion protruding from said locking arm and at least one interlock receiving aperture disposed in said base, said interlock protrusion and said interlock receiving aperture sized and adapted to interlock when said locking arm is disposed in said second position.

11. The device of claim 7, wherein said at least one interlock receiving aperture is disposed in at least one of said first and second sidewalls of said base portion.

12. The device of claim 7, wherein said at least one interlock receiving aperture is disposed in said base portion wall of said base portion.

13. The device of claim 7, wherein said flexible tooth-like member is provided with serrations.

14. A device for selectively securing a zipper cord substantially as hereinbefore described with reference to and as shown in the accompanying drawings.



Application No: GB 9824031.0
Claims searched: 1-13

Examiner: Philip Silvie
Date of search: 21 January 1999

Patents Act 1977
Search Report under Section 17

Databases searched:

UK Patent Office collections, including GB, EP, WO & US patent specifications, in:

UK Cl (Ed.Q): E2A (AGKD, AGH, AGKFC)

Int Cl (Ed.6): A44B (11/12); F16G (11/10)

Other:

Documents considered to be relevant:

Category	Identity of document and relevant passage	Relevant to claims
A	GB 1 247 781 A (BENGTSSON) see figs. 1,2	1,7
A	GB 1 164 345 A (WALSALL) see figs. 2,3	1,7
A	US 5 469 583 A (BELL) see figs. 4A, 4B	1,7
X	US 4 639 978 A (BODEN) see column 6, lines 20-53	1-4, 6-10,12,13
X	US 4 373 234 A (BODEN) see fig. 5	1-5, 7-11,13

X Document indicating lack of novelty or inventive step
Y Document indicating lack of inventive step if combined with one or more other documents of same category.
& Member of the same patent family

A Document indicating technological background and/or state of the art.
P Document published on or after the declared priority date but before the filing date of this invention.
E Patent document published on or after, but with priority date earlier than, the filing date of this application.