



US006581341B1

(12) **United States Patent**
Baratuci et al.

(10) **Patent No.:** **US 6,581,341 B1**
(45) **Date of Patent:** **Jun. 24, 2003**

(54) **CONTINUOUS FLEXIBLE SPACER ASSEMBLY HAVING SEALANT SUPPORT MEMBER**

(75) Inventors: **James Lynn Baratuci**, Stow, OH (US); **Ronald Ellsworth Buchanan**, London, KY (US); **Patrick Anthony Drda**, Lyndhurst, OH (US); **Louis Anthony Ferri**, Solon, OH (US); **Eric W. Jackson**, Willoughby, OH (US)

(73) Assignee: **TruSeal Technologies**, Beachwood, OH (US)

(*) Notice: Subject to any disclaimer, the term of this patent is extended or adjusted under 35 U.S.C. 154(b) by 0 days.

(21) Appl. No.: **09/692,919**

(22) Filed: **Oct. 20, 2000**

(51) **Int. Cl.**⁷ **E06B 3/66**

(52) **U.S. Cl.** **52/204.5; 52/786.13; 52/786.11; 52/786.1; 52/172; 428/34**

(58) **Field of Search** **52/204.5, 408, 52/786.13; 428/34, 181**

(56) **References Cited**

U.S. PATENT DOCUMENTS

2,828,235 A	*	3/1958	Holland et al.	154/118
4,576,841 A	*	3/1986	Lingemann	428/34
4,791,773 A	*	12/1988	Taylor	52/790
5,013,377 A		5/1991	Lafond	
5,209,034 A	*	5/1993	Box et al.	52/171
5,270,091 A	*	12/1993	Krysiak et al.	428/68
5,436,040 A		7/1995	Lafond	
5,441,779 A		8/1995	Lafond	
5,443,871 A		8/1995	Lafond	
5,447,761 A		9/1995	Lafond	
5,472,558 A		12/1995	Lafond	
5,485,710 A		1/1996	Lafond	
5,491,953 A		2/1996	Lafond	

5,498,451 A	3/1996	Lafond	
RE35,291 E	7/1996	Lafond	
5,616,415 A	4/1997	Lafond	
5,635,019 A	6/1997	Lafond	
5,650,029 A	7/1997	Lafond	
5,656,358 A	8/1997	Lafond	
5,658,645 A	8/1997	Lafond	
5,691,045 A	11/1997	Lafond	
5,759,665 A	6/1998	Lafond	
5,762,738 A	6/1998	Lafond	
5,773,135 A	6/1998	Lafond	
5,806,272 A	9/1998	Lafond	
5,813,191 A	* 9/1998	Gallagher	52/786.13
5,851,609 A	* 12/1998	Baratuci et al.	428/34
5,876,554 A	3/1999	Lafond	
5,888,341 A	3/1999	Lafond	
5,975,181 A	11/1999	Lafond	
6,001,453 A	12/1999	Lafond	
6,035,602 A	* 3/2000	Lafond	52/786.13
D422,884 S	4/2000	Lafond	
6,148,890 A	11/2000	Lafond	
6,192,652 B1	* 2/2001	Goer et al.	52/786.13
6,250,358 B1	6/2001	Lafond	
6,329,030 B1	12/2001	Lafond	

FOREIGN PATENT DOCUMENTS

EP	500483 A1	*	2/1992
WO	9726434		7/1997
WO	WO 97/26434	*	7/1997

* cited by examiner

Primary Examiner—Carl D. Friedman

Assistant Examiner—Basil Katcheves

(74) *Attorney, Agent, or Firm*—Renner, Otto, Boisselle & Sklar, LLP

(57) **ABSTRACT**

A spacer and sealant strip comprising a sealant support member having a longitudinal axis and a planer surface bounded by first and second edges, a stiffener cooperating with said sealant support member, a shim in contact with said stiffener and said sealant support member, and a sealant.

26 Claims, 3 Drawing Sheets

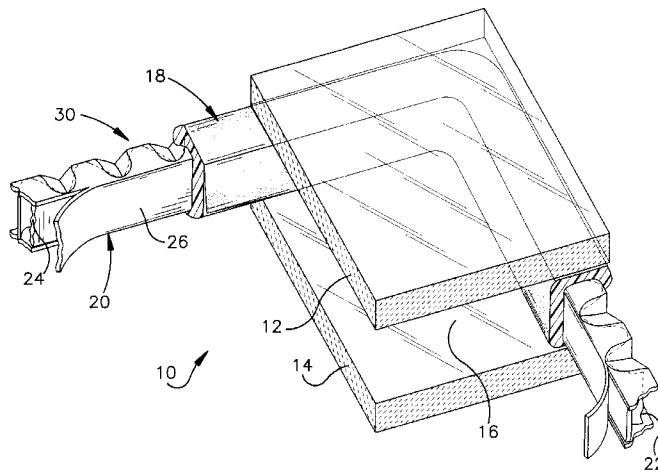

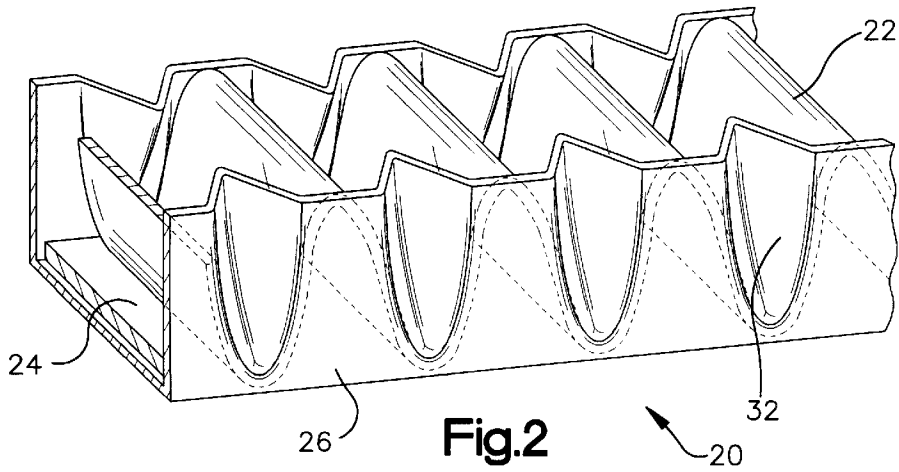
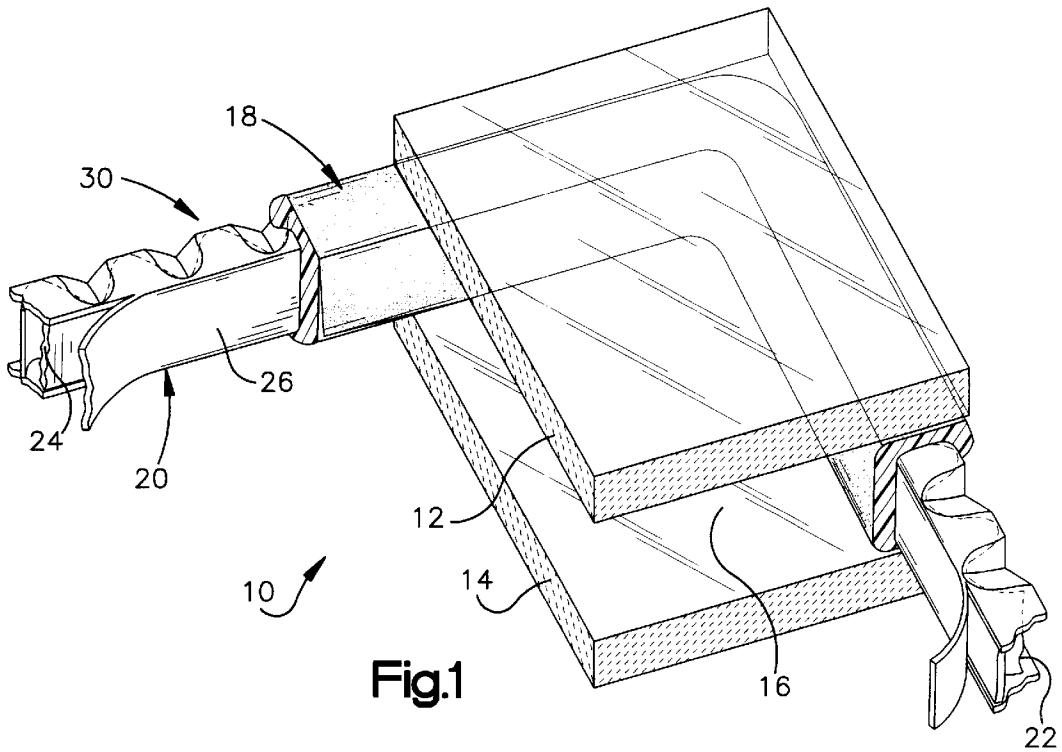

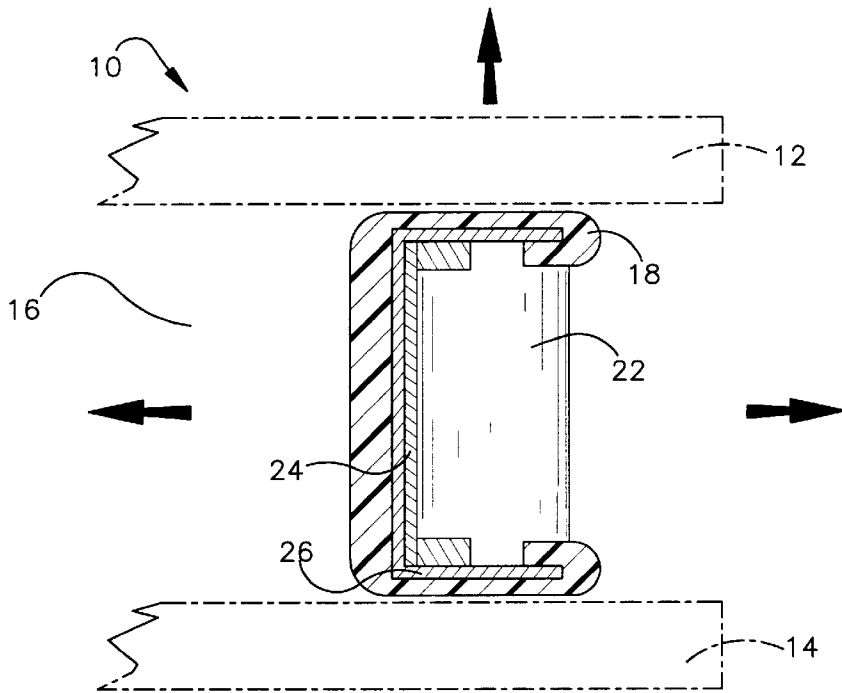

Fig.3

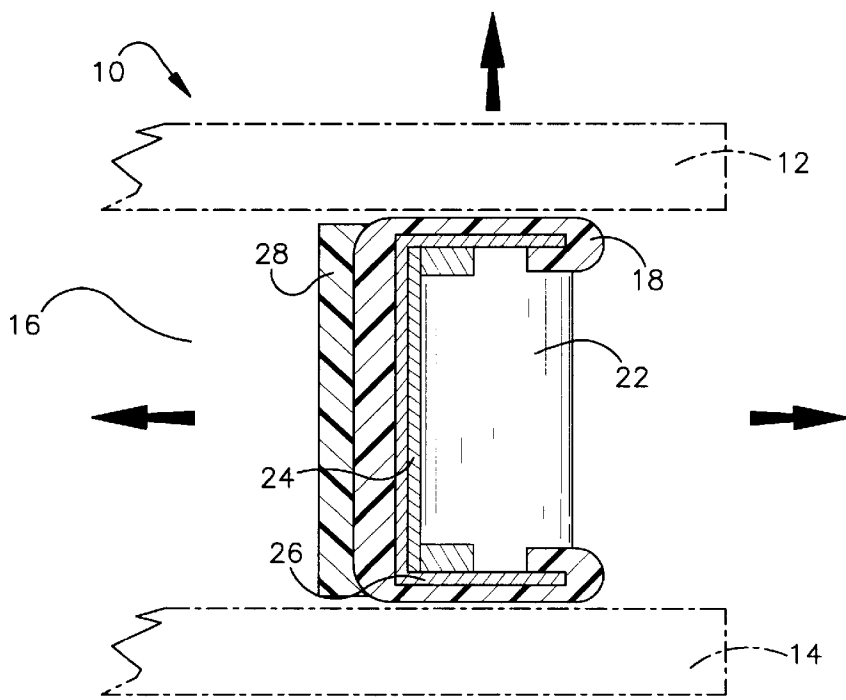
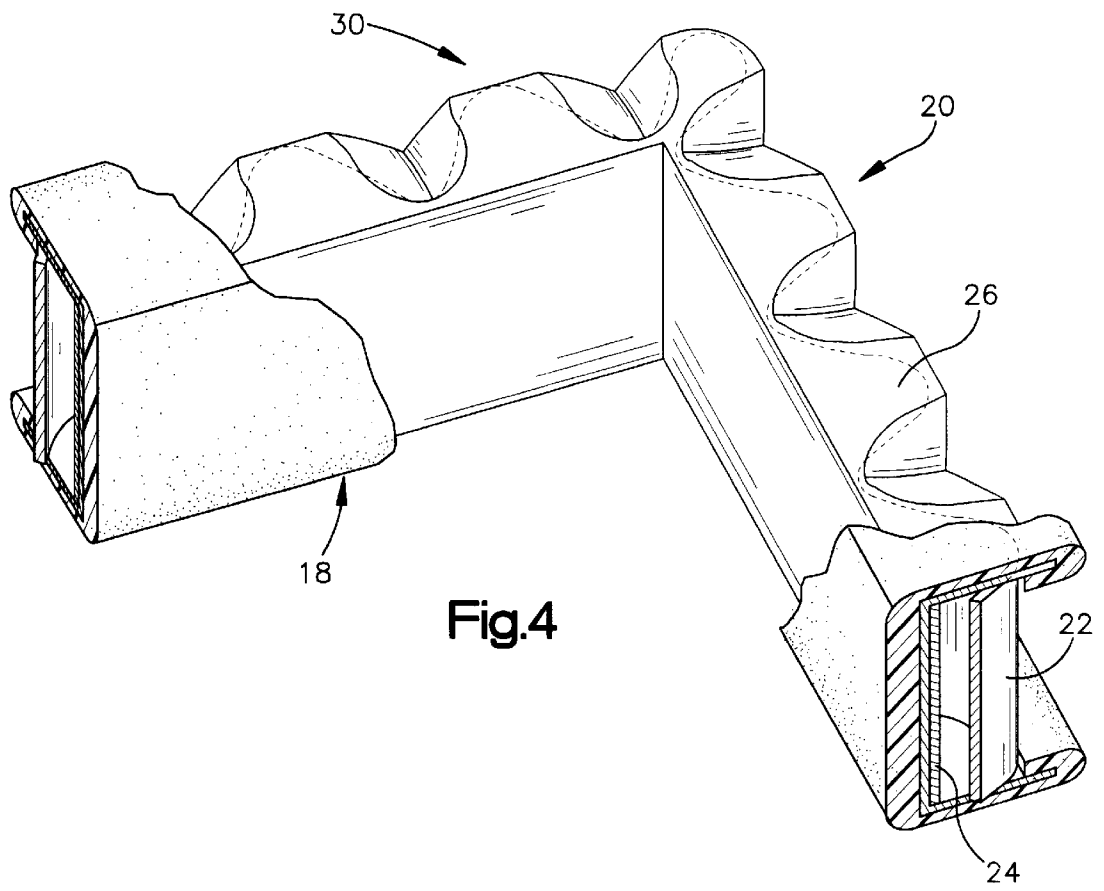

Fig.3A



**CONTINUOUS FLEXIBLE SPACER
ASSEMBLY HAVING SEALANT SUPPORT
MEMBER**

FIELD OF INVENTION

This invention relates to a composite spacer and sealant which can be used particularly in the fabrication of thermal insulating laminates such as windows.

BACKGROUND OF INVENTION

In general, the procedure for assembling an insulated window assembly involves placing one sheet of a glazed structure over another in a fixed, spaced relationship, and then injecting a sealant composition into the space between the two glazed structures, at and along the periphery of the two structures, thereby forming a sandwich-type structure having a sealed air pocket between the structures. In practice, glazed structures are typically glass sheets, but can also be plastic or other such suitable materials. To keep the glazed structures properly spaced apart, a spacer bar is often inserted between the two structures to maintain proper spacing while the sealant composition is injected into place. Also, the spacer bar and sealant can be prefabricated into a solitary unit and after fabrication placed into the space between the glazed structures to form the window structure.

Moisture and organic materials are often trapped inside the sealed air space as a result of the window assembly fabrication process. To minimize the effects of moisture and organic materials trapped in the sealed air pocket, desiccants can be used as a medium to absorb these artifacts. Typically, however, at least some moisture will diffuse into the sealed air pocket during the time the window assembly is in field service. This use of desiccants keeps moisture concentration low and thus prevents the moisture from condensing on and fogging interior surface of the glass sheets when the window assembly is in service. Desiccants can be incorporated into the spacer, into the sealant or into the entire sealant/spacer when the sealant/spacer assembly is a solitary component. Additional desiccant above the amount required to absorb the initial moisture content is included in the spacer/sealant assembly in order to absorb additional moisture entering the window assembly over its service life.

Various prior art practices for manufacturing windows are cumbersome, labor intensive or require expensive equipment. An answer to the previously discussed limitations is provided by U.S. Pat. No. 4,431,691, to Greenlee, in which a sealant and spacer strip having a folded or contoured spacer means to maintain the relative distance under compression of glass sheets, wherein the strip comprises a folded or contoured spacer means embedded or enveloped in a deformable sealant. This spacer strip has the advantage of being flexible along its longitudinal axis to enable it to be coiled for storage. The Greenlee assembly is thus a solitary component in which the sealant contains the desiccant.

Greenlee's assembly, while addressing previous limitations does not provide a flat sight line once the glass unit is constructed due to undulations in the spacer after the glazed structure are compressed into place. The sightline in a window is the portion of the spacer/sealant assembly that is viewed through the glass sheets, but is not in contact with these sheets. This flat sightline is desirable to improve aesthetic qualities of installed windows. Also, the Greenlee teaching uses high amounts of sealant material required to envelope the spacer and the folded assembly can be stretched during application as well as along its longitudinal

axis. This stretching can also lead to problems in maintaining a flat sightline.

To resolve some of Greenlee's shortcomings, U.S. patent application Ser. No. 08/585,822 (abandoned), filed in the PCT as PCT/US97/00258 and published as WO97/26434 (abandoned) shows use of a continuous flexible spacer assembly having a shim connected to stiffener resulting in a longitudinal flexible spacer strip. The spacer assembly has a so-called "open cell" construction. While this construction solves some of Greenlee's problems associated with the sightline, the open cell construction does not provide adequate support to the sealant when in contact with the glass sheets. Accordingly, this shim/stiffener construction is not suitable for maintaining a sealed window assembly over extended periods because the spacer/member bond, i.e. the bondline, tends to lose adhesion and become unsealed.

SUMMARY OF THE INVENTION

There remains a need for an improved flexible continuous spacer assembly that eliminates longitudinal stretching and, accordingly, makes it easier to consistently produce a window having a smooth sightline. Moreover, it would be desirable if such assembly allowed for a sharper radius when bending the sealant and spacer at the corners as compared to the prior art. Also, a need exists for improved lateral stability of the strip, while providing a more cost-effective product having the benefits of the Greenlee construction and other prior art. Finally, the assembly would provide the required support to maintain the adhesive seal between the spacer assembly and the glazed structures over the life of the window unit.

Thus, the sealant and spacer strip of the present invention provides the advantages over the prior art of eliminating the amount of necessary sealant material while maintaining the performance of the sealant and spacer strip; eliminating the tendency of the material to stretch along its longitudinal axis; improving the appearance of the sightline of the window; improving the durability of the bondline and providing the necessary ability to form sharper corners.

It is a further object of the present invention to provide an improved, longitudinally flexible, but laterally stable sealant and spacer assembly for application in the assembly of multiple glazed structures as well as for other laminates which can be coiled for storage and easier application.

In accordance with one aspect of the present invention, there is provided a flexible, crush-resistant sealant and spacer strip or composite tape structure comprising a longitudinally extending spacer, including an undulating strip of rigid material, a longitudinally coextending planar strip of a stiffener material and a longitudinally coextending sealant support member which is joined to the edges of the undulating strip and stiffener material. A deformable adhesive sealant is also included which seals the stiffener, shim and sealant support member to the glass sheets. The spacer is capable of resisting compressive forces exerted in a direction normal to a plane in which the longitudinal axis of the spacer lies, is in cooperation with the stiffener and maintains the ability to be coiled for storage.

BRIEF DESCRIPTION OF DRAWINGS

FIG. 1 is a fragmentary perspective view with parts in section showing an embodiment of a window made in accordance with the present invention;

FIG. 2 is a fragmentary perspective view of a spacer in accordance with the present invention;

FIG. 3 is a cross-section of the spacer assembly of the embodiment of FIG. 1;

FIG. 3A is a cross-section of the spacer assembly of the present invention showing use of a topcoat;

FIG. 4 is a perspective view of the spacer in accordance with the preferred embodiment of the present invention.

DETAILED DESCRIPTION

Referring now to the drawings, it will be seen that FIG. 1 illustrates a composite structure, such as but not limited to a window assembly, **10** comprising first substrate member **12** and second substrate member **14** having facing, generally parallel surfaces. First and second substrate members **12, 14** and are generally glass panes of a multiple glazed structure. The substrate members are **12, 14** joined together to form an enclosed space **16** which is hermetically sealed by a composite tape structure, i.e., sealant and spacer strip, which includes sealant **18** which at least partially envelopes a spacer assembly **20**. Members **12, 14** are formed of glass. However, it will be appreciated that the invention has applicability in the environment of an unrestricted variety of construction or structural materials, including, for example, cement, concrete, brick, stone, metals, plastics, and wood.

In accordance with a preferred embodiment of the invention, the spacer assembly **20** includes an undulating strip of rigid material, i.e., a "shim" **22** a generally planar strip of rigid material, i.e., a stiffener **24** which is coextending with, and preferably intermittently joined to the shim **22** at the peak of each of the undulations on one side of the shim **22** and a sealant support member **26**. The spacer assembly **20** is generally characterized as a linear series of adjoining hollow columns which may comprise tubular or prismatic cells. Thus, the spacer assembly **20** can loosely be referred to as "honey-combed." By "undulating," it is meant that the shim **22** has a repeating contour which gives edge-to-edge structural integrity in the "z" direction, i.e., parallel to the long axis of the cells as illustrated in FIG. 3. The undulations may include folds, ribs, creases, and sinusoidal waves having a cross-sectional profile which can be curved or angular or any combination thereof. Typically, the undulations will have a "peak" and a corresponding "valley" as is understood in the art and illustrated in FIG. 2. The amplitude of the shim **22** is the peak-to-peak distance.

As illustrated in FIGS. 1 and 3, for purposes of this patent, "interior" means facing into the sealed air pocket **16** of the window assembly **10** while "exterior" means facing out of the sealed air pocket **16** of the window assembly **10**. Also, FIG. 3 illustrates the orientation of the x, y, and z axes as used herein.

A particularly favorable undulating shim **22** profile includes flat surfaces at the peaks of the undulations which can be adhered to the sealant support member **26** with the stiffener **24** resting or attached to an interior surface of the sealant support member **26** relative to the interior of the window assembly **10**. However, it should be appreciated that the stiffener **24** could be attached to the opposing interior surface of the sealant support member **26** and still achieve the same benefits. Further, the undulations provide the shim **22** with a profile which is capable of resisting compressive forces in the "z" direction.

Consequently, spacer assembly **20** is "crush-resistant," i.e., capable of resisting forces tending to reduce the spacing between members during use. Moreover, the spacer assembly **20** with stiffener **24** is more resistant to torque or twisting about the longitudinal axis than the shim **22** by itself. This aspect of the invention facilitates the ease of application of

this spacer assembly **20** while reducing the twist due to torsional forces since prior art spacers tended to twist during assembly of multiple glazed structures. It should be understood that it would be within the scope of the invention to construct the spacer assembly **20** as a single unit rather than an assembly of components.

The shim **22** can be formed of any material having sufficient rigidity to resist compressive forces exerted in a direction normal to the parallel planes in which the edges of the undulating strip lie. Suitable materials include steel, stainless steel, aluminum, coated paper, cardboard, plastics, foamed plastics, metalized plastics or laminates of any combination of the above.

The undulations of the shim **22** are generally transverse to the longitudinal axis to ensure flexibility for coiling or winding about the z-axis. The frequency of the undulations may range from 1 to about 10 per inch, preferably from about 2 to about 8 per inch, and most preferably from about 2 to about 5 per inch, while the total amplitude, i.e., thickness of the crest and trough together in the x-y plane, is from about 0.05 to about 0.5 inch with from about 0.08 to about 0.25 inch being preferred. For some applications, however, one of skill in the art will readily appreciate that larger configurations may be needed.

In accordance with the present invention, the compressive load strength of the spacer assembly **20** is augmented by the presence of the stiffener **24**, which is coextensive with the shim **22**. The stiffener **24** is preferably in cooperation with the peaks in the undulations of the shim **22**. The stiffener **24** may be fabricated from plastic, aluminum, steel, stainless steel, coated paper or any thermoset or thermoplastic foam as well as any laminate made from any combination of the above list. Plastic, however, preferred. The shim **22** is attached to an exterior surface of the sealant support member **26**. One method of adhering the sealant support member **26** and the shim **22** is for the sealant support member **26** to include an adhesive layer which is intermediate to the sealant support member **26** and the shim **22**.

Suitable thicknesses for the sealant support member **26** range from about 0.001 to about 0.06 inch, preferably from about 0.001 to about 0.03 inch, and most preferably from about 0.002 to about 0.015 inch. The shim **22** has a thickness of from about 0.003 to about 0.012 inch, preferably from about 0.003 to about 0.04 inch, and most preferably from about 0.005 to about 0.01 inch when the shim **22** is formed from a metallic material. The stiffener has a thickness of from about 0.005 to 0.06 and most preferably from 0.006 to 0.03. These ranges will be used in the typical window assembly **10** with one of skill in the art readily appreciating that larger ranges may be utilized if necessary.

The sealant support member **26** may be fabricated from aluminum foil, plastic, plastic laminates, paper/foil, metalized plastic or any other suitable combination of the above with a plastic/aluminum laminate being preferred.

The sealant **18** seals the gap formed between the sealant support member and the substrate surfaces **12, 14**. Thus at least the two longitudinal edges of the sealant support member **26** include longitudinally extending ribbons of sealant **18** which are of sufficient width to provide a low-permeability seal. In particular, the sealant **18** adheres to at least the opposing longitudinal edges of the sealant support member **26**. The sealant **18** may also include a lateral face so as to have generally a U-shaped cross-section.

Suitable dimensions for the composite sealant and spacer assembly **30** will depend upon the window construction with the length corresponding generally to the window perimeter

length. The width will correspond to the desired spacing between the glazed structures. The spacer assembly **20**, however, will often be slightly smaller than the desired spacing between the glazed structures **12, 14** with the addition of the sealant **18** to the assembly resulting in a slightly greater width than the desired spacing. The desired spacing is obtained during manufacture when the glazed structures **12, 14** are pressed into the final desired thickness. It should be understood, however, that the present invention can be manufactured in continuous lengths for any desired length resulting in flexibility for any application.

The shim **22** can be manufactured by any of various methods. For example, it can be extruded, stamped, pressed, vacuum-molded, or crimped, depending upon the material used. The shim **22** can be joined to the stiffener **24** by any suitable means such as by welding, thermally fusing, joining with adhesives or by crimping the shim **22** to the stiffener **24**. The stiffener **24** can also be joined to the sealant support member **26** by similar such treatments.

The sealant **18** can subsequently be applied to the spacer assembly **20** such as by dipping, painting, injecting or extruding the sealant **18** to the lateral edges of the sealant support member **26**. Desiccant can be carried in the sealant **18** and the sealant/desiccant can be applied to the edges and interior surface of the sealant support member **26** in a single step. In another embodiment, as illustrated in FIG. **3A**, a topcoat **28** containing desiccant is adhered to the sealant **18** on its interior surface(s). By using the desiccated topcoat **28**, a desiccated sightline is formed. Alternatively, the desiccant can be applied to the sealant support member **26** facing the interior of the window.

The spacer assembly **20** of the preferred embodiment, comprising a shim **22** attached to a stiffener **24** with both secured to a sealant support member **26** to define a honeycomb or cellular structure, has several important advantages over the prior art. The columnar aspect shim **22**, sealant support member **26** and stiffener **24** of the spacer assembly **20** improves its compressive strength and improves the resistance to torque about the longitudinal axis. Moreover, the stiffener **24** and the sealant support member **26** act as a longitudinally stable backing which inhibits the shim **22** from stretching along its longitudinal axis. Furthermore, the sealant support member **26** improves the bondline formed between the sealant **18** and the glazed structures **12, 14** by keeping the sealant **18** in contact with both glazed members **12, 14**.

As best illustrated in FIG. **2**, the sealant support member **26** may be pleated or crimped to facilitate forming corners. Pleated as used herein means any formation in the sealant support member **26** that allows stretching when forming corners. Thus, as used herein, pleated includes pleats, gussets, crimps or folds. The pleats **32** of the sealant support member **26** allow for sharper corners without tearing or otherwise damaging the spacer assembly **20**. The pleats **32** also provide for flexibility necessary to bend the sealant/spacer assembly **30** into corners and to allow for coiling of the sealant/spacer assembly **30**.

In a preferred embodiment of the invention, the planar face of the sealant support member **26** is interior of the shim **22** and carries a sealant **18** and/or topcoat **28** along the sight line. However, it should be understood that the fabrication of the sealant/spacer assembly **30** may be reversed so that the undulations of the shim **22** carry the sealant **18** and/or topcoat **28** and form the sight line, and the sealant support member **26** is substantially free from sealant and faces the exterior of the window assembly **10**. Finally, the sealant/

spacer assembly **30** serves to displace sealant as taught in the prior art so as to reduce the sealant adhesive which is necessary to achieve an effective seal. This results in a substantial reduction in the amount of sealant used.

As previously noted, elongated ribbons of deformable sealant **18** are carried by at least the lateral edges of spacer assembly **20**. The thickness to which elongated ribbon extends beyond the surfaces and edges of spacer assembly **20** is not critical as an absolute measurement, but is important in terms of functional considerations. For most applications, where the surfaces of the two members **12, 14** being sealed are relatively smooth, the thickness of the sealant **18** extending beyond the spacer assembly **20** should be in the range of 0.005–0.015 inch for each edge. Because the surfaces of tempered glass may not be as flat as the surfaces untempered glass, somewhat greater thicknesses may be required to provide tempered glass with an adequate seal.

The term “deformable” as used herein, is intended to characterize a sealant, whether thermoplastic, thermosetting, or thermoplastic-thermosetting, which when used in the fabrication of composite structures **10** contemplated by this invention, is at least initially incapable of resisting deforming forces exerted upon it. Thus, the term deformable is intended to characterize a material which resists deformation or flow under low forces placed on a window assembly **10** throughout its lifetime, but is readily deformable under higher forces encountered during manufacture of a window assembly **10**.

A wide variety of materials may be used as the base for the adhesive sealant **18**, including polysulfide polymers, urethane polymers, acrylic polymers, and the styrene-butadiene polymers. Included among the latter are a class of thermoplastic resins which, when below their flow temperature, exhibit elastic properties of vulcanized polymers. Such resins are sold by Shell Chemical Co. under the trademark “Kraton.” A preferred class of sealants **18** is butyl rubbers. The adhesive sealant **18**, however, is preferably a pressure sensitive adhesive which is thixotropic. If a topcoat **28** is applied, the topcoat **28** is preferably a desiccant loaded, deformable material.

Window assemblies **10** often require a desiccant to lower the concentration of moisture and organic materials trapped in the air space **16** between the two glazed structures **12, 14** of the window assembly **10**. Conveniently, in the present invention, the desiccant can be incorporated within the deformable adhesive sealant **18** and this can be applied to the front face of the sealant **18** or, alternatively, a different material containing desiccant can be used and co-extruded or otherwise applied to the sight line of the spacer means. A particularly suitable class of desiccant is synthetically produced crystalline zeolite sold by UOP Corporation under the name “Molecular Sieves.” Another desiccant which may be used is silica gel. Combinations of different desiccants are also contemplated.

In a preferred embodiment, the back or exterior face of the shim **22** is substantially free from sealant **18** and more particularly is substantially free from sealant **18** which includes a desiccant. By “substantially free” it is meant that at least one-third and more preferably one-half or even three-fourths (depending on the ultimate window gap width) of the exterior surface of the shim **22** is free of sealant **18**. More specifically, the peaks of the shim **22** may contain the sealant **18**, but the valleys of the shim **22** will be relatively free from the sealant **18**. As is shown in FIG. **3**, the sealant **18** and/or topcoat **28** is advantageously U-shaped before it is

applied to the window assembly **10**. Thus, the sealant **18** and/or topcoat **28** extends along the lateral face of the spacer assembly **20**, i.e., the sightline, and along the lateral edges, i.e., the bond line.

The preferred method of manufacturing the sealant/spacer assembly **30** in accordance with the present invention is by co-extrusion. This can be accomplished with commercially available co-extruding equipment which, in some instances, may require minor modification. In general, a previously formed or immediately pre-formed spacer assembly **20** is fed through the center of an extrusion die and the deformable sealant **18** is extruded about the spacer assembly **20** leaving its exterior surface substantially free from sealant **18**. The composite material is then fed through a sizing die to obtain a sealant/spacer assembly **30** having the desired outside dimensions and the proper thickness of sealant **18** extending beyond the spacer assembly **20**. A releasable liner or paper is contacted longitudinally along the sightline for ease of coiling. As the sealant/spacer assembly **30** is applied to form a window assembly **10**, the releasable liner is removed and discarded. One of skill in the art will readily appreciate that other well known methods may be used to produce the invention.

In one embodiment, the spacer assembly **20** of the present invention is constructed by forming the shim **22** by passing it through intermeshing gears to make the undulations. After the shim **22** is formed, the stiffener **24** is joined to the shim **22** using an adhesive. The adhesive can be placed on the stiffener **24** as the shim **22** comes off the gears or the adhesive can be pre-applied. The now joined shim/stiffener can then be joined to the sealant support member **26** also using an adhesive. In one embodiment, the shim/stiffener are centered on a flat sealant support member **26** bearing an adhesive. Opposing edges of the sealant support member **26** are then folded to contact the sides of the shim **22**. The sealant **18** and if desired, the topcoat **28**, are then adhered to the spacer assembly **20** as previously described. While one of skill in the art will appreciate that any variety of adhesives may be used, it is preferred that the adhesives maintain a degree of flexibility within the spacer assembly **20**.

Alternately, the sealant **18** may be extruded onto both edges of the pre-formed spacer assembly **20** and a topcoat **28** may simultaneously or sequentially be applied to the front lateral surface of the spacer assembly **20**, such as by co-extrusion, coating, or other lamination techniques. This topcoat **28** may be a different material from the sealant **18** and may be formulated for aesthetic purposes, for desiccating purposes, or other reasons.

Finally, while the embodiments described herein relate to window assemblies having two glazed structures, one of skill would readily understand that window assemblies having multiple glazed structures such as triple-paned window assemblies can be formed using the present invention. In another embodiment, a groove or indentation is formed in the sealant **18** and/or topcoat **28** along the sightline. A glazed member can be placed into this groove to form a triple-paned window assembly.

While in accordance with the patent statutes the best mode and preferred embodiment has been set forth, the scope of the invention is not limited thereto, but rather by the scope of the attached claims.

What is claimed is:

1. A spacer and sealant assembly comprising:

a stretchable sealant support member having a planar surface bounded by first and second edges wherein said first and second edges have at least one pleated portion;

a shim having at least one undulating portion in contact with said first and second edges of said stretchable sealant support member so that said at least one pleated portion is oriented concavely inward into said at least one undulating portion of said shim to facilitate bending; and

a sealant joined to at least said first and second edges of said sealant support member.

2. The spacer and sealant assembly of claim 1 further comprising a stiffener in contact with said stretchable sealant support member.

3. The spacer and sealant assembly of claim 2 further comprising a topcoat having a desiccant and joined to said sealant.

4. The spacer and sealant assembly of claim 3 wherein said shim is undulating along a longitudinal axis.

5. The spacer and sealant assembly of claim 4 wherein said stiffener is adhered to said stretchable sealant support member by a first adhesive.

6. The spacer and sealant assembly of claim 5 wherein said stiffener is adhered to said shim by a second adhesive.

7. The spacer and sealant assembly of claim 6 wherein said shim is adhered to said stretchable sealant support member by a third adhesive.

8. A spacer and sealant assembly comprising:

a stretchable sealant support member having a planar surface bounded by first and second edges wherein said first and second edges are crimped to form at least one pleated portion;

a stiffener in contact with said planar surface of said sealant support member;

a shim undulating along a longitudinal axis and partially in contact with said first and second edges of said stretchable sealant support member wherein said at least one pleated portion extends generally inward within at least one void created by the undulations to form at least one bendable prismatic cell; and

a sealant joined to at least said first and second edges of said sealant support member.

9. The spacer and sealant assembly of claim 8 further comprising a topcoat having a desiccant and joined to said sealant.

10. The spacer and sealant assembly of claim 9 wherein said stiffener is adhered to said stretchable sealant support member by a first adhesive.

11. The spacer and sealant assembly of claim 10 wherein said stiffener is further adhered to said shim by a second adhesive.

12. The spacer and sealant assembly of claim 11 wherein said shim is adhered to said stretchable sealant support member by a third adhesive.

13. The spacer and sealant assembly of claim 12 wherein said assembly is coilable.

14. A window assembly comprising:

a stretchable sealant support member having a planar surface bounded by first and second edges wherein said first and second edges have at least one pleated portion;

a shim having at least one undulating portion in contact with said first and second edges of said stretchable sealant support member so that said at least one pleated portion is oriented concavely inward into said at least one undulating portion of said shim to facilitate bending;

a sealant joined to at least said first and second edges of said sealant support member and having first and second glass engaging surfaces;

9

a first glass structure adhered to said first glass engaging surface of said sealant; and
a second glass structure adhered to said second glass engaging surface.

15. The spacer and sealant assembly of claim 14 further comprising a stiffener in contact with said stretchable sealant support member.

16. The spacer and sealant assembly of claim 15 further comprising a topcoat having adesiccant joined to said sealant.

17. The spacer and sealant assembly of claim 16 wherein said shim is undulating in a longitudinal axis.

18. The spacer and sealant assembly of claim 17 wherein said stiffener is adhered to said stretchable sealant support member by a first adhesive.

19. The spacer and sealant assembly of claim 18 wherein said stiffener is adhered to said shim by a second adhesive.

20. The spacer and sealant assembly of claim 19 wherein said shim is adhered to said stretchable sealant support member by a third adhesive.

21. A window assembly comprising:

a sealant support member having a planar surface bounded by first and second edges wherein said first and second edges are crimped to form at least one pleated portion;

a stiffener in contact with said planar surface of said sealant support member;

a shim undulating along a longitudinal axis and partially in contact with said first and second edges of said stretchable sealant support member wherein said at least one pleated portion extends generally inward within at least one void created by the undulations to form at least one bendable prismatic cell;

a sealant joined to at least said first and second edges of said sealant support member and having substantially parallel first and second glass engaging surfaces;

10

a first glass structure adhered to said first glass engaging surface of said sealant; and

a second glass structure adhered to said second glass engaging surface of said sealant.

22. The spacer and sealant assembly of claim 21 further comprising a topcoat having a desiccant joined to said sealant.

23. The spacer and sealant assembly of claim 21 wherein said stiffener is adhered to said stretchable sealant support member by a first adhesive.

24. The spacer and sealant assembly of claim 23 wherein said stiffener is adhered to said shim by a second adhesive.

25. The spacer and sealant assembly of claim 24 wherein said shim is adhered to said stretchable sealant support member by a third adhesive.

26. A method for forming a spacer sealant strip for joining and hermetically sealing two substantially parallel surfaces comprising the steps of:

forming a shim generally undulating along a longitudinal axis;

at least partially crimping first and second edges of a stretchable sealant support member to form at least one partially pleated portion;

joining said shim to shim joining-surfaces of first and second edges of a stretchable sealant support member so that said at least one pleated portion extends generally inward within at least one void created by the undulations to form at least one bendable prismatic cell;

joining a stiffener to a planar surface of said stretchable sealant support member; and

applying a deformable adhesive sealant to at least sealant joining surface of said first and second edges of said stretchable sealant support member.

* * * * *