

(12) **UK Patent Application** (19) **GB** (11) **2579750** (13) **A**

(43) Date of Reproduction by UK Office **01.07.2020**

(21) Application No: **2003414.6**  
(22) Date of Filing: **31.08.2017**  
Date Lodged: **09.03.2020**  
(86) International Application Data:  
**PCT/US2017/049679 En 31.08.2017**  
(87) International Publication Data:  
**WO2019/045736 En 07.03.2019**

(51) INT CL:  
**C09D 101/02** (2006.01) **B05D 5/00** (2006.01)  
**B05D 7/24** (2006.01) **C09D 5/02** (2006.01)  
**C09D 123/00** (2006.01) **C09D 191/06** (2006.01)

(56) Documents Cited:  
**WO 2011/161173 A1** **WO 2005/077429 A1**  
**US 20140323633 A1** **US 20130273368 A1**  
**US 20080145664 A1**

(58) Field of Search:  
INT CL **A61L, B05D, B23B, C09D, D21H**  
Other: **eKOMPASS (KIPO internal)**

(71) Applicant(s):  
**Kimberly-Clark Worldwide, Inc.**  
**2300 Winchester Road, Neenah 54956, Wisconsin,**  
**United States of America**

**The Board of Trustees of the University of Illinois**  
**352 Henry Administration Building,**  
**506 S.Wright Street, Urbana 61801, IL,**  
**United States of America**

(72) Inventor(s):  
**Jian Qin**  
**Donald E Waldroup**  
**Corey T Cunningham**  
**Constantine M Megaridis**  
**Jared Morrissette**  
**Patrick Carroll**  
**Ilker S. Bayer**

(74) Agent and/or Address for Service:  
**Dehns**  
**St. Bride's House, 10 Salisbury Square, LONDON,**  
**EC4Y 8JD, United Kingdom**

(54) Title of the Invention: **Superhydrophobic surfaces using non-fluorinated compositions with plant-based materials**

Abstract Title: **Superhydrophobic surfaces using non-fluorinated compositions with plant-based materials**

(57) A superhydrophobic surface includes a substrate treated with a composition including a hydrophobic matrix component free of fluorine; filler particles, wherein the filler particles are plant-based elements of a size ranging from 100 nm to 100 µm; and water, wherein the hydrophobic component is in an aqueous dispersion, and wherein the surface exhibits a water contact angle of 150° or greater. Also, a disposable absorbent article includes a substrate having a surface, the surface including a composition including a hydrophobic matrix component free of fluorine; filler particles, wherein the filler particles are plant-based elements of a size ranging from 100 nm to 100 µm, wherein the plant-based elements include micro- and nano-fibrillated cellulose; and water, wherein the hydrophobic component is in an aqueous dispersion, and wherein the surface exhibits a water contact angle of 150° or greater.

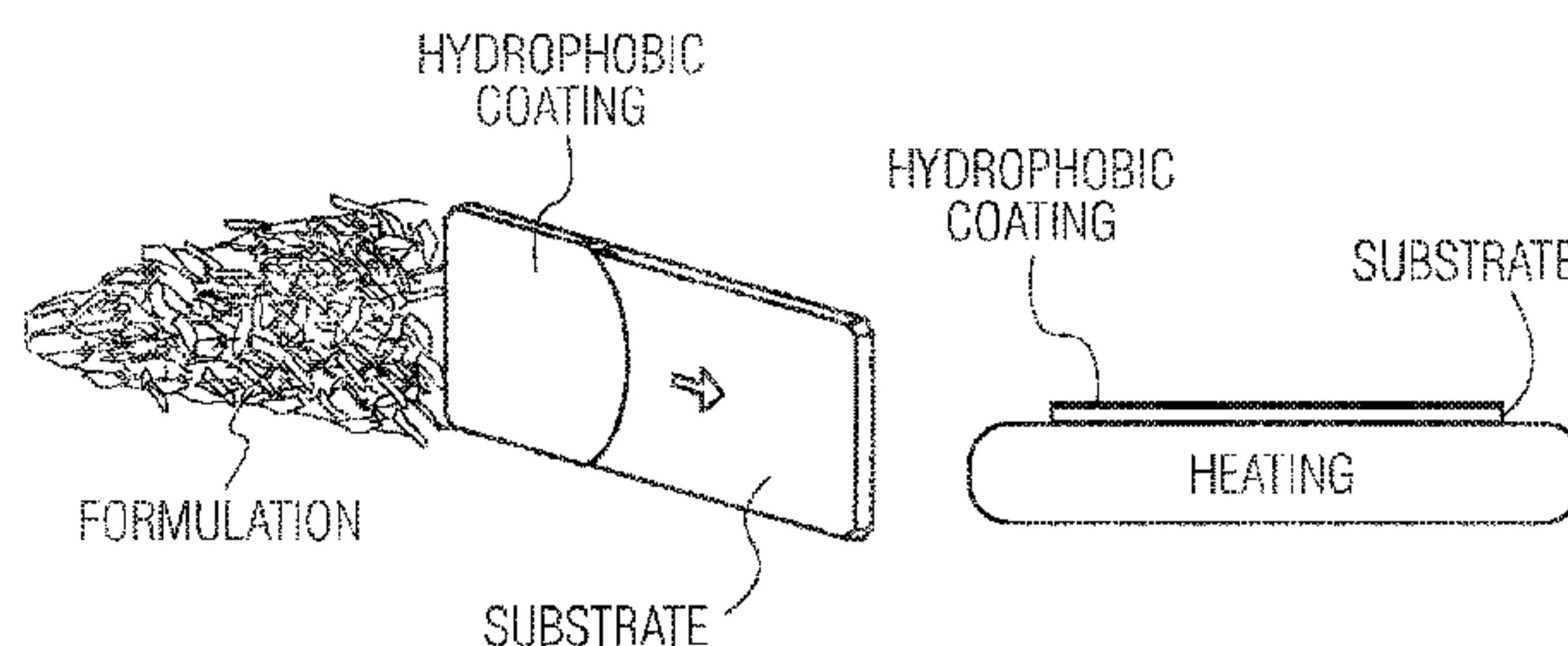

FIG. 1

GB 2579750 A