



US00RE46313E

(19) **United States**  
(12) **Reissued Patent**  
**Johnson et al.**

(10) **Patent Number:** **US RE46,313 E**  
(45) **Date of Reissued Patent:** **Feb. 21, 2017**

(54) **WELDING CART**

(71) Applicants: **Travis Johnson**, Eagan, MN (US);  
**David Anderson**, Appleton, WI (US)

(72) Inventors: **Travis Johnson**, Eagan, MN (US);  
**David Anderson**, Appleton, WI (US)

(73) Assignee: **Northern Tool & Equipment Company, Inc.**, Burnsville, MN (US)

(21) Appl. No.: **29/492,097**

(22) Filed: **May 28, 2014**

**Related U.S. Patent Documents**

Reissue of:

(64) Patent No.: **Des. 629,028**  
Issued: **Dec. 14, 2010**  
Appl. No.: **29/360,173**  
Filed: **Apr. 21, 2010**

(51) **LOC (10) Cl.** ..... **15-09**

(52) **U.S. Cl.**  
USPC ..... **D15/144**

(58) **Field of Classification Search**  
USPC ..... D15/144, 144.1, 144.2; D34/12-27;  
219/136; 414/444, 448, 466, 469, 546;  
280/47.131, 47.19, 47.26, 47.27, 47.33,  
280/47.34, 47.35, 79.5, 79.6, 79.7

See application file for complete search history.

(56) **References Cited**

**U.S. PATENT DOCUMENTS**

2,891,802 A \* 6/1959 Moran ..... 280/654  
D202,616 S 10/1965 Larson  
(Continued)

*Primary Examiner* — Phillip S Hyder

(74) *Attorney, Agent, or Firm* — Patterson Thuent  
Pedersen, P.A.

(57) **CLAIM**

The ornamental design for a welding cart, as shown and described.

**DESCRIPTION**

[FIG. 1 is a front perspective view of a welding cart according to the invention;]

[FIG. 2 is a top plan view of the welding cart depicted in FIG. 1;]

[FIG. 3 is a left side elevation view of the welding cart depicted in FIG. 1;]

[FIG. 4 is a right side elevation view of the welding cart depicted in FIG. 1;]

[FIG. 5 is a front elevation view of the welding cart depicted in FIG. 1; and,]

[FIG. 6 is a rear elevation view of the welding cart depicted in FIG. 1.]

*FIG. 7 is a front perspective view of a welding cart according to an embodiment of the invention;*

*FIG. 8 is a top plan view of the welding cart depicted in FIG. 7;*

*FIG. 9 is a left side elevation view of the welding cart depicted in FIG. 7;*

*FIG. 10 is a right side elevation view of the welding cart depicted in FIG. 7;*

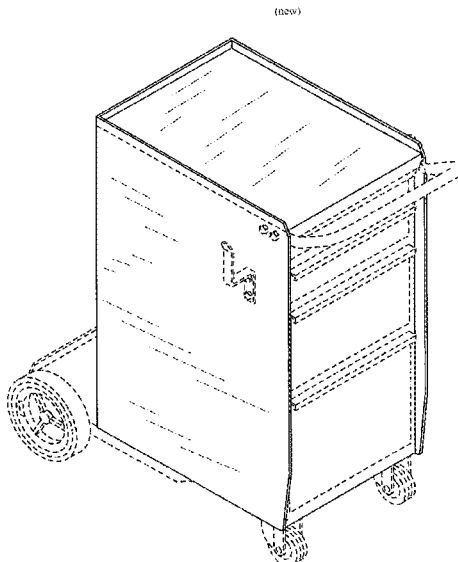
*FIG. 11 is a front elevation view of the welding cart depicted in FIG. 7; and,*

*FIG. 12 is a rear elevation view of the welding cart depicted in FIG. 7.*

*The broken lines depict portions of the welding cart in which the design is embodied that are not considered part of the claimed design.*

**1 Claim, 8 Drawing Sheets**

**Matter enclosed in heavy brackets [ ] appears in the original patent but forms no part of this reissue; matter printed in italics indicates the additions made by reissue.**



(56)

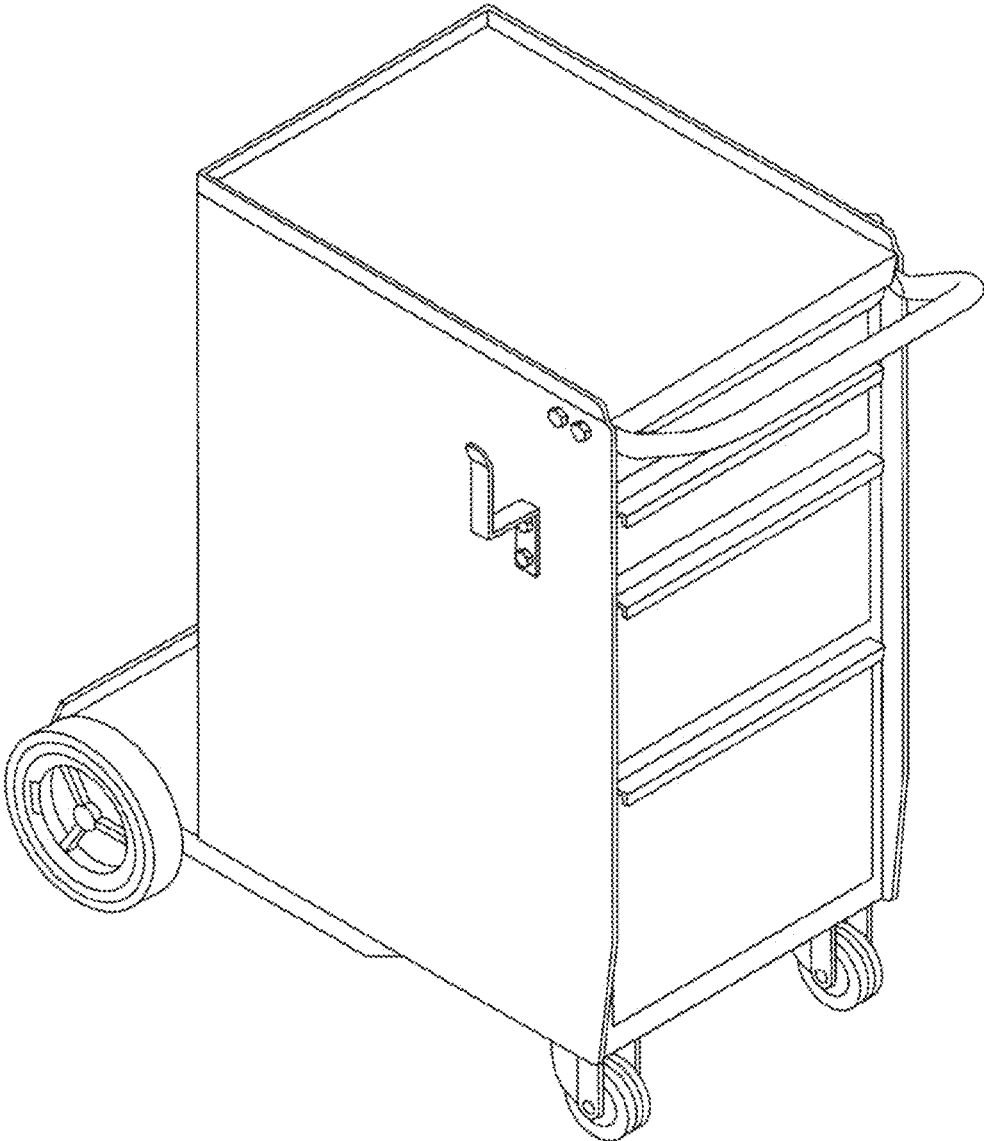
**References Cited**

U.S. PATENT DOCUMENTS

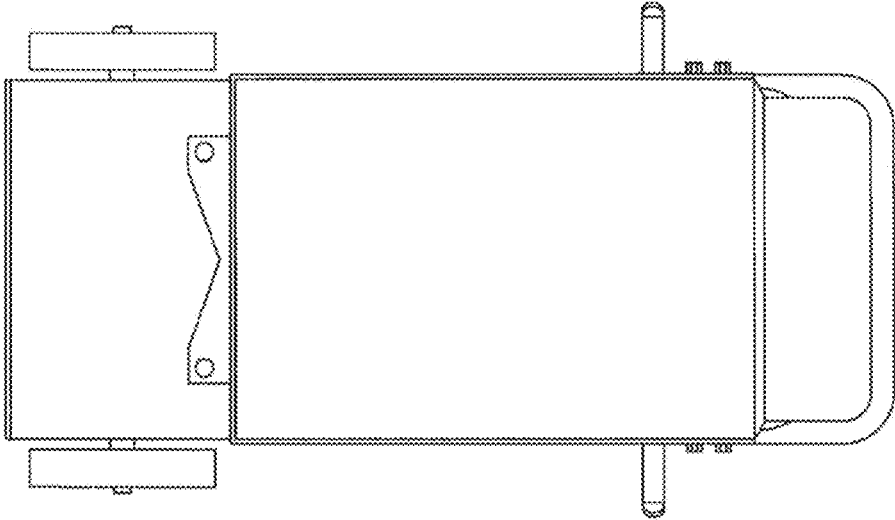
4,726,485	A *	2/1988	Bailey	220/6
D322,501	S *	12/1991	Legault	D34/24
D330,789	S *	11/1992	Powell	D34/5
D361,643	S *	8/1995	Snell	D34/21
6,590,184	B1 *	7/2003	Andersen	219/136
D530,875	S *	10/2006	Rosine et al.	D34/17
D546,017	S *	7/2007	Wise	D34/19
7,252,297	B1	8/2007	Barritt et al.	
7,338,054	B2 *	3/2008	Pint	280/79.2
D567,464	S	4/2008	Dullum	
7,357,398	B2 *	4/2008	O'Connor	280/47.34
7,374,185	B1 *	5/2008	Hollis	280/47.35
D575,023	S *	8/2008	Girard	D34/19
D598,622	S *	8/2009	Wise	D34/19
D612,562	S *	3/2010	Henderson	D34/24

\* cited by examiner

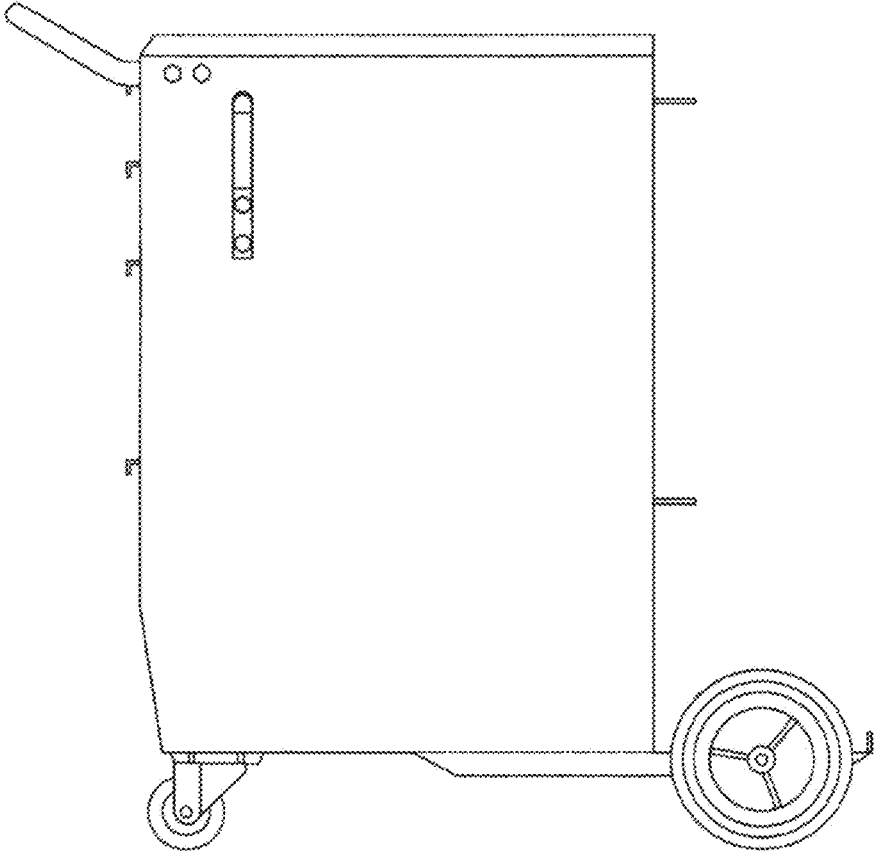
**Fig. 1** (Cancelled)



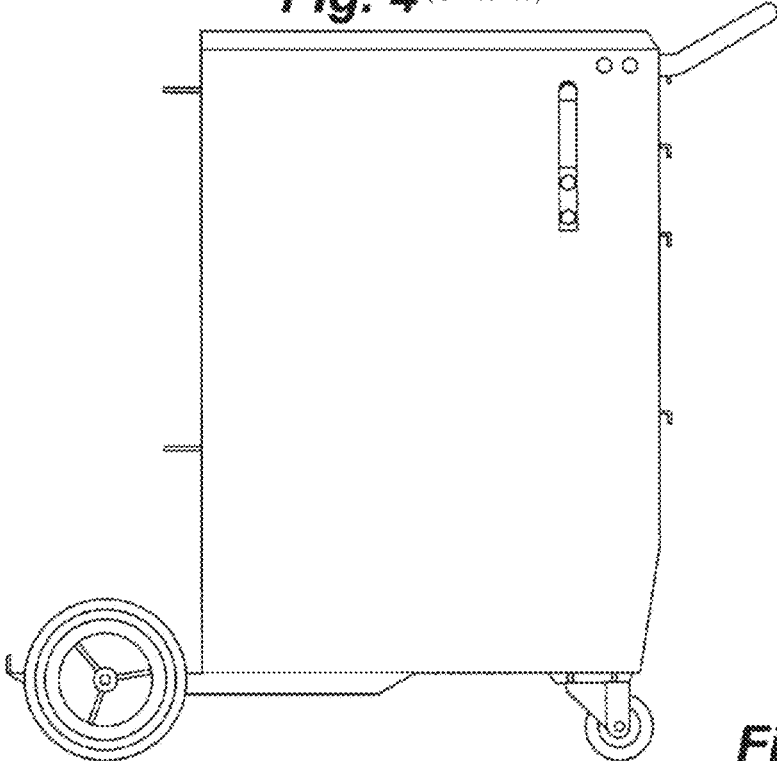
**Fig. 2** (Cancelled)



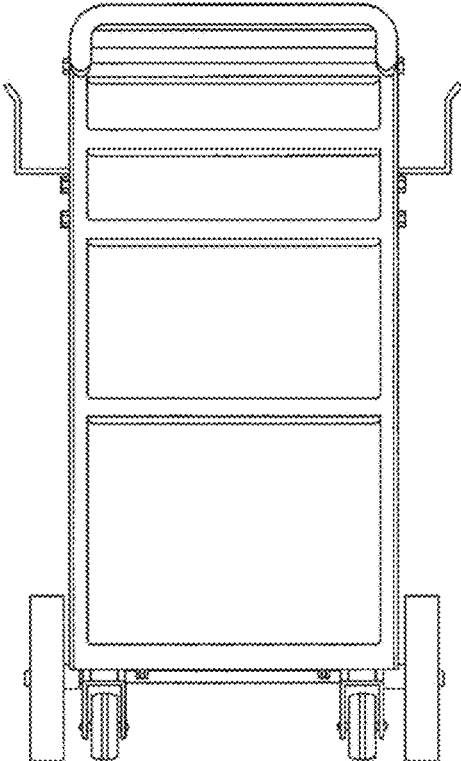
**Fig. 3** (Cancelled)



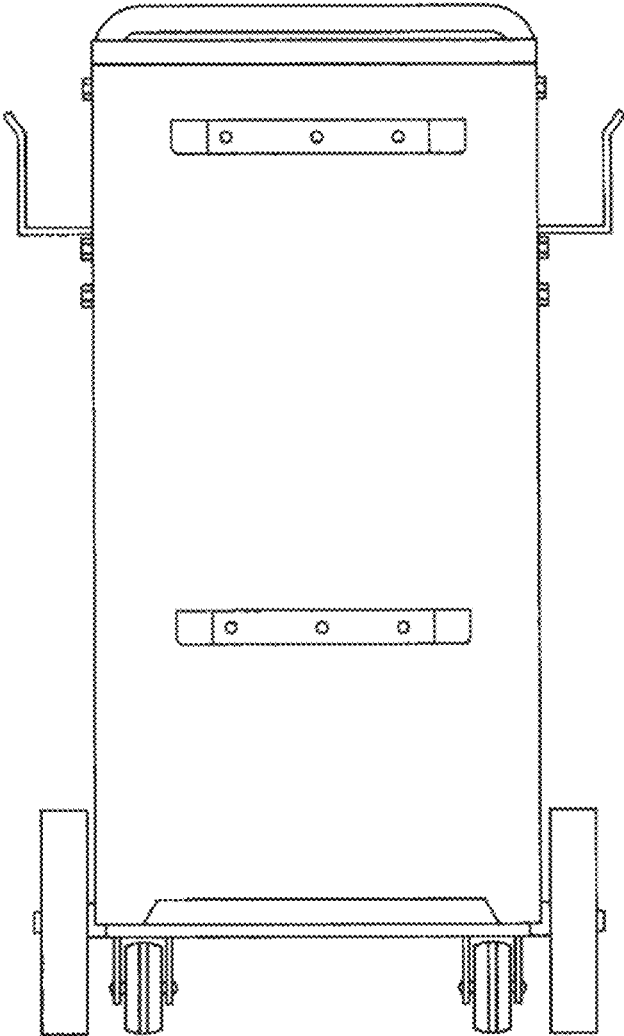
**Fig. 4** (Cancelled)



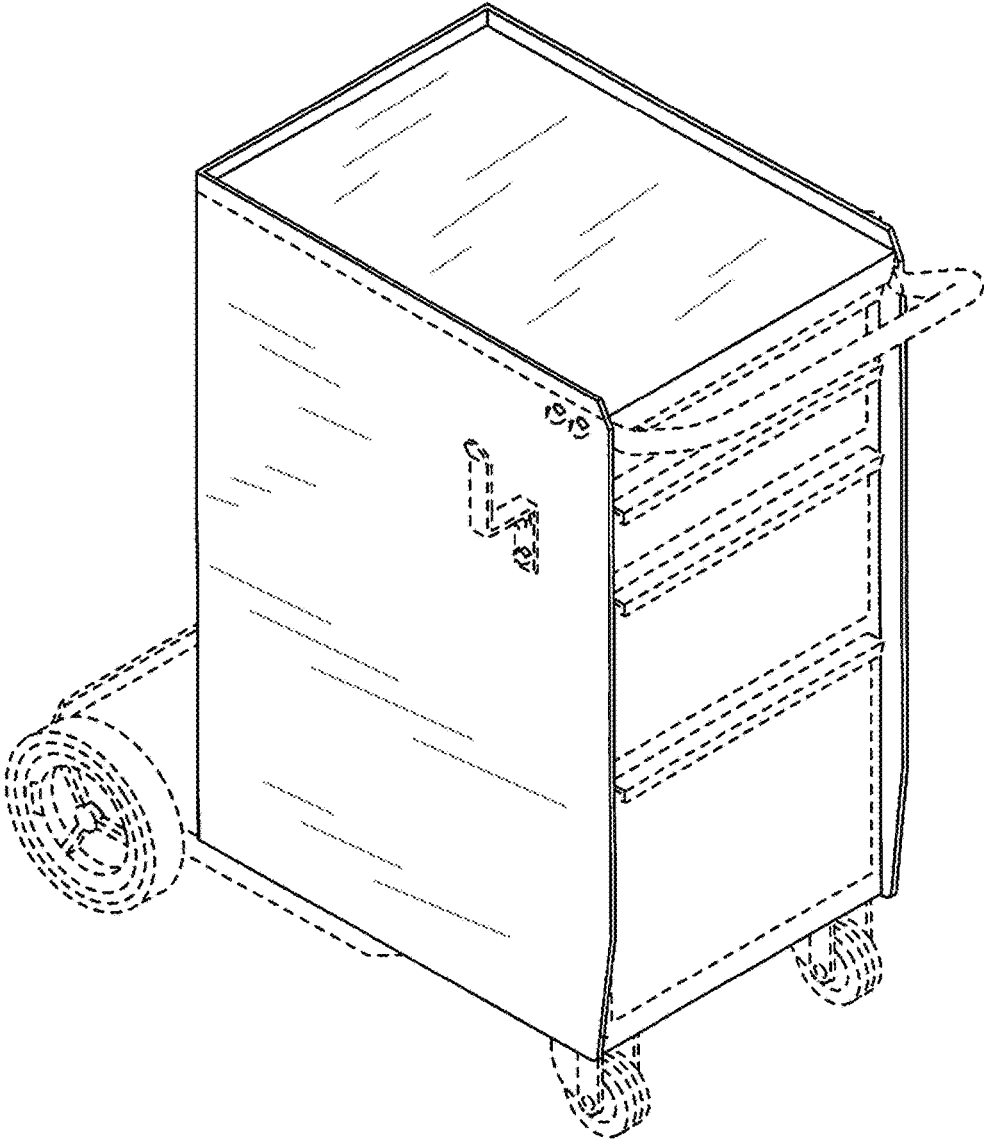
**Fig. 5** (Cancelled)



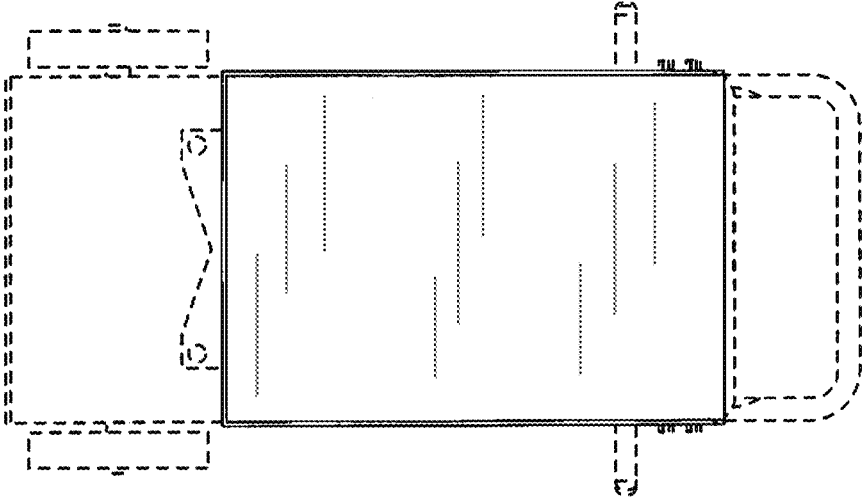
**Fig. 6** (Cancelled)



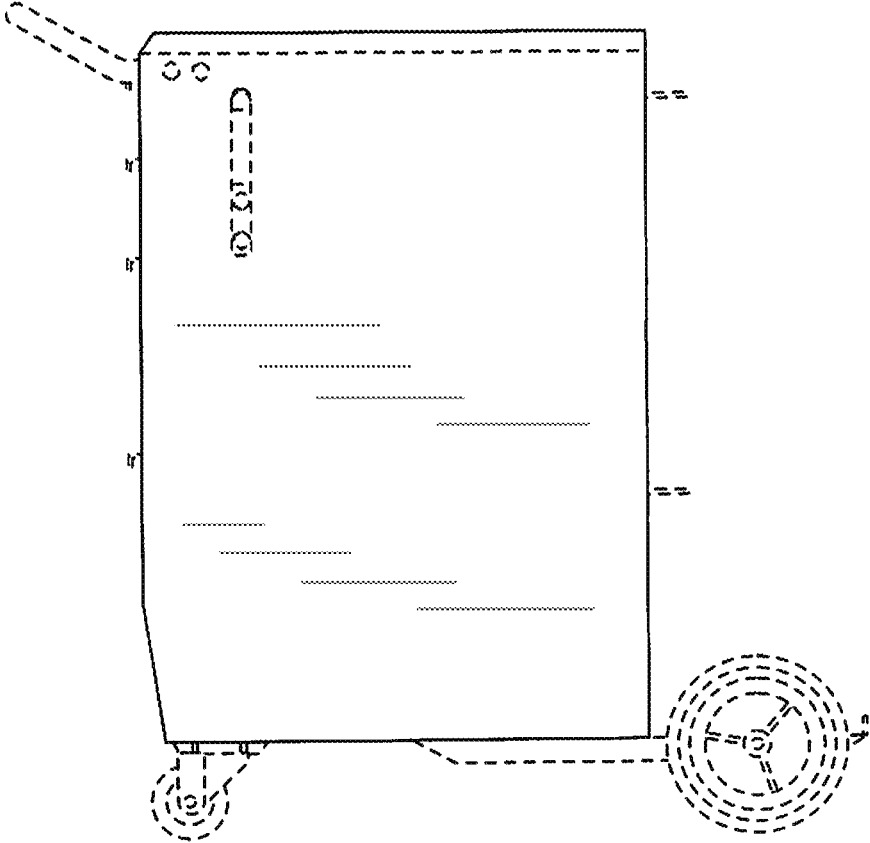
**Fig. 7** (new)



**Fig. 8** (new)

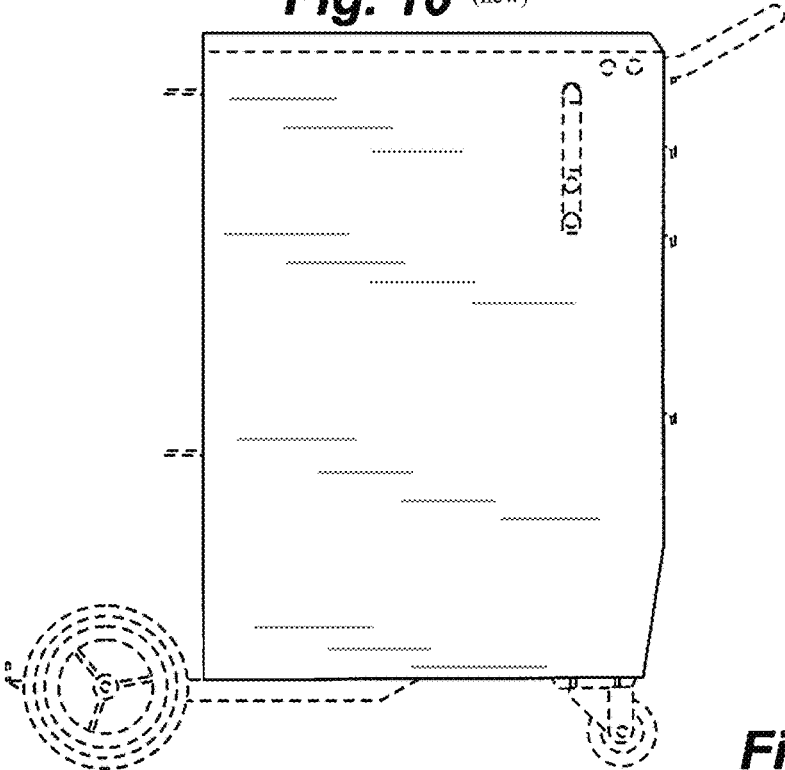


**Fig. 9** (new)

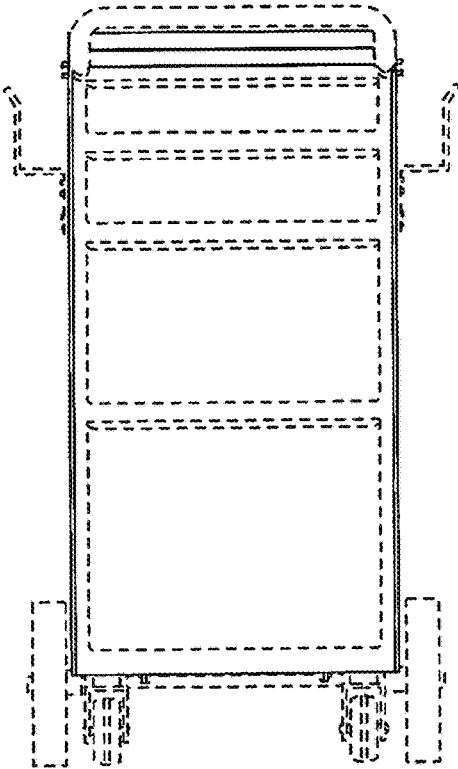




**Fig. 10** (new)



**Fig. 11** (new)



**Fig. 12** (new)

