

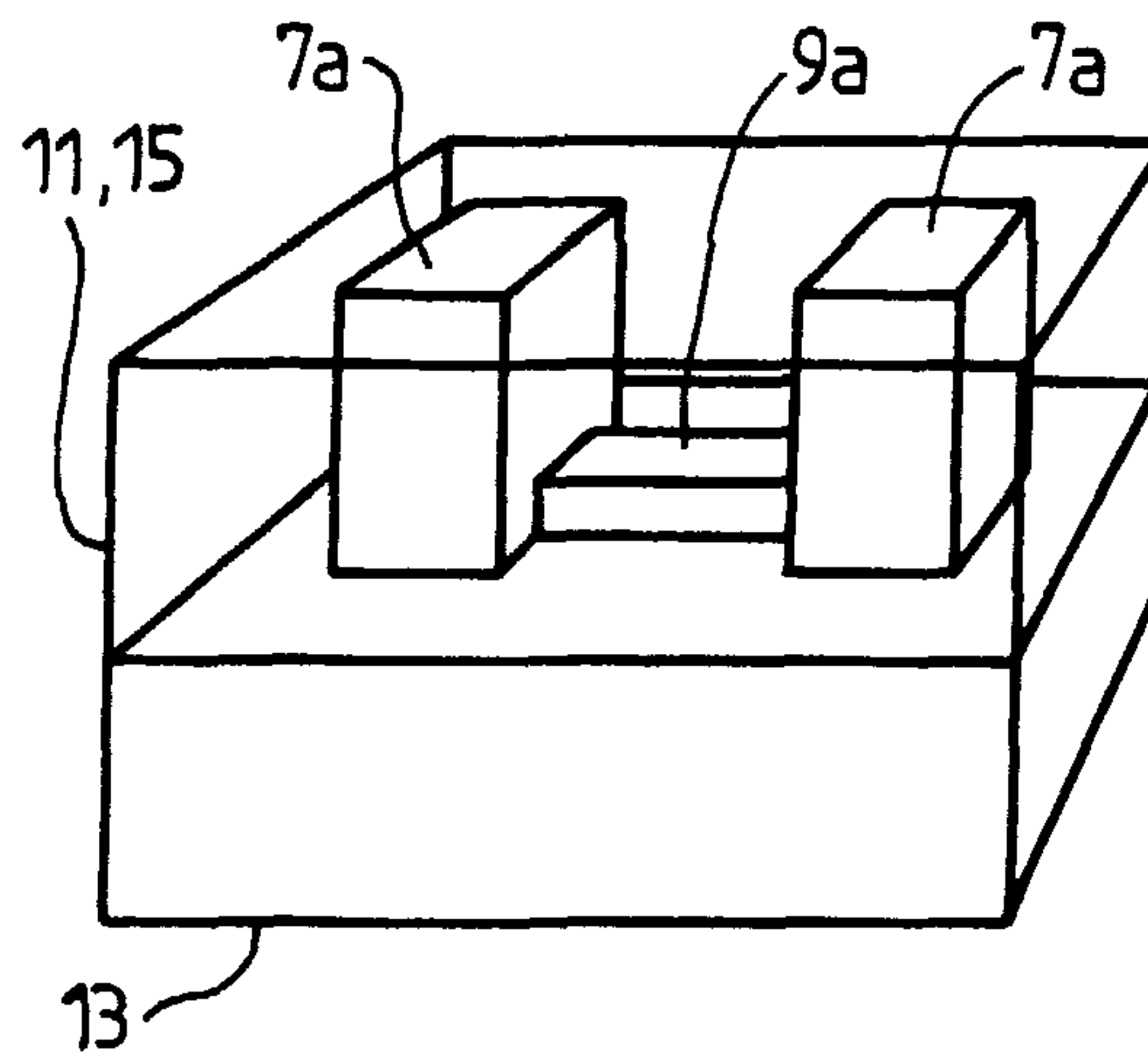

(86) Date de dépôt PCT/PCT Filing Date: 2001/06/08
 (87) Date publication PCT/PCT Publication Date: 2002/12/19
 (85) Entrée phase nationale/National Entry: 2003/12/01
 (86) N° demande PCT/PCT Application No.: EP 2001/007058
 (87) N° publication PCT/PCT Publication No.: 2002/100542

(51) Cl.Int.⁷/Int.Cl.⁷ B01L 3/00
 (71) Demandeur/Applicant:
 CENTRE NATIONAL DE LA RECHERCHE
 SCIENTIFIQUE, FR
 (72) Inventeurs/Inventors:
 LE PIOUFLE, BRUNO, FR;
 FUJITA, HOROYUKI, JP;
 TAMIYA, EIICHI, JP;
 GRISCOM, LAURENT, FR;
 DEGENAAR, PATRICK, JP
 (74) Agent: BORDEN LADNER GERVAIS LLP

(54) Titre : PROCEDE DE FABRICATION D'UNE STRUCTURE MICROFLUIDIQUE, EN PARTICULIER UNE PUCE A ADN ET STRUCTURE OBTENUE PAR LEDIT PROCEDE
 (54) Title: METHOD OF MANUFACTURING A MICROFLUIDIC STRUCTURE, IN PARTICULAR A BIOCHIP, AND STRUCTURE OBTAINED BY SAID METHOD



(57) **Abrégé/Abstract:**

A method of manufacturing a microfluidic structure, in particular a biochip, said method consisting at least :- in manufacturing a three-dimensional micro-mould with means for defining a three-dimensional geometry including at least micro-wells and micro-grooves or micro-channels interconnecting said micro-wells ; and- in using only said three-dimensional micro-mould for molding a membrane made of a polymer material, said membrane incorporating at least said micro-wells and said micro-grooves or micro-channels, said membrane constituting a three-dimensional microfluidic structure.

(12) INTERNATIONAL APPLICATION PUBLISHED UNDER THE PATENT COOPERATION TREATY (PCT)

(19) World Intellectual Property Organization
International Bureau(43) International Publication Date
19 December 2002 (19.12.2002)

PCT

(10) International Publication Number
WO 02/100542 A1

- (51) International Patent Classification⁷: **B01L 3/00**
- (21) International Application Number: PCT/EP01/07058
- (22) International Filing Date: 8 June 2001 (08.06.2001)
- (25) Filing Language: English
- (26) Publication Language: English
- (71) Applicant (for all designated States except US): **CENTRE NATIONAL DE LA RECHERCHE SCIENTIFIQUE** [FR/FR]; 3, rue Michel-Ange, F-75794 Paris Cedex 16 (FR).
- (72) Inventors; and
- (75) Inventors/Applicants (for US only): **LE PIOUFLE, Bruno** [FR/FR]; 88, rue du Moulin Vert, F-75014 Paris (FR). **FUJITA, Horoyuki** [JP/JP]; 9-14 Senkawa 1-chome, Toshima-ku, Tokyo 1711-0041 (JP). **TAMIYA, Eiichi** [JP/JP]; School of Materials Science, Japan Advanced Institute of Science and Technology, Tatsunokuchi, Ishikawa 923-1292 (JP). **GRISCOM, Laurent** [FR/FR]; 50, rue de Paris, F-35000 Rennes (FR). **DEGENAAR, Patrick** [NL/JP]; Bld 5-503, Jaist dormitory, Jaist, 1-8 Asahidai, Tatsunokuchi, Nomi-gum, Ishikawa 923-1211 (JP).
- (74) Agent: **CABINET ORES**; 6, avenue de Messine, F-75008 Paris (FR).
- (81) Designated States (*national*): AE, AG, AL, AM, AT, AU, AZ, BA, BB, BG, BR, BY, BZ, CA, CH, CN, CR, CU, CZ, DE, DK, DM, DZ, EE, ES, FI, GB, GD, GE, GH, GM, HR, HU, ID, IL, IN, IS, JP, KE, KG, KP, KR, KZ, LC, LK, LR, LS, LT, LU, LV, MA, MD, MG, MK, MN, MW, MX, MZ, NO, NZ, PL, PT, RO, RU, SD, SE, SG, SI, SK, SL, TJ, TM, TR, TT, TZ, UA, UG, US, UZ, VN, YU, ZA, ZW.
- (84) Designated States (*regional*): ARIPO patent (GH, GM, KE, LS, MW, MZ, SD, SL, SZ, TZ, UG, ZW), Eurasian patent (AM, AZ, BY, KG, KZ, MD, RU, TJ, TM), European patent (AT, BE, CH, CY, DE, DK, ES, FI, FR, GB, GR, IE, IT, LU, MC, NL, PT, SE, TR), OAPI patent (BF, BJ, CF, CG, CI, CM, GA, GN, GW, ML, MR, NE, SN, TD, TG).
- Published:**
— with international search report
- For two-letter codes and other abbreviations, refer to the "Guidance Notes on Codes and Abbreviations" appearing at the beginning of each regular issue of the PCT Gazette.

(54) Title: METHOD OF MANUFACTURING A MICROFLUIDIC STRUCTURE, IN PARTICULAR A BIOCHIP, AND STRUCTURE OBTAINED BY SAID METHOD

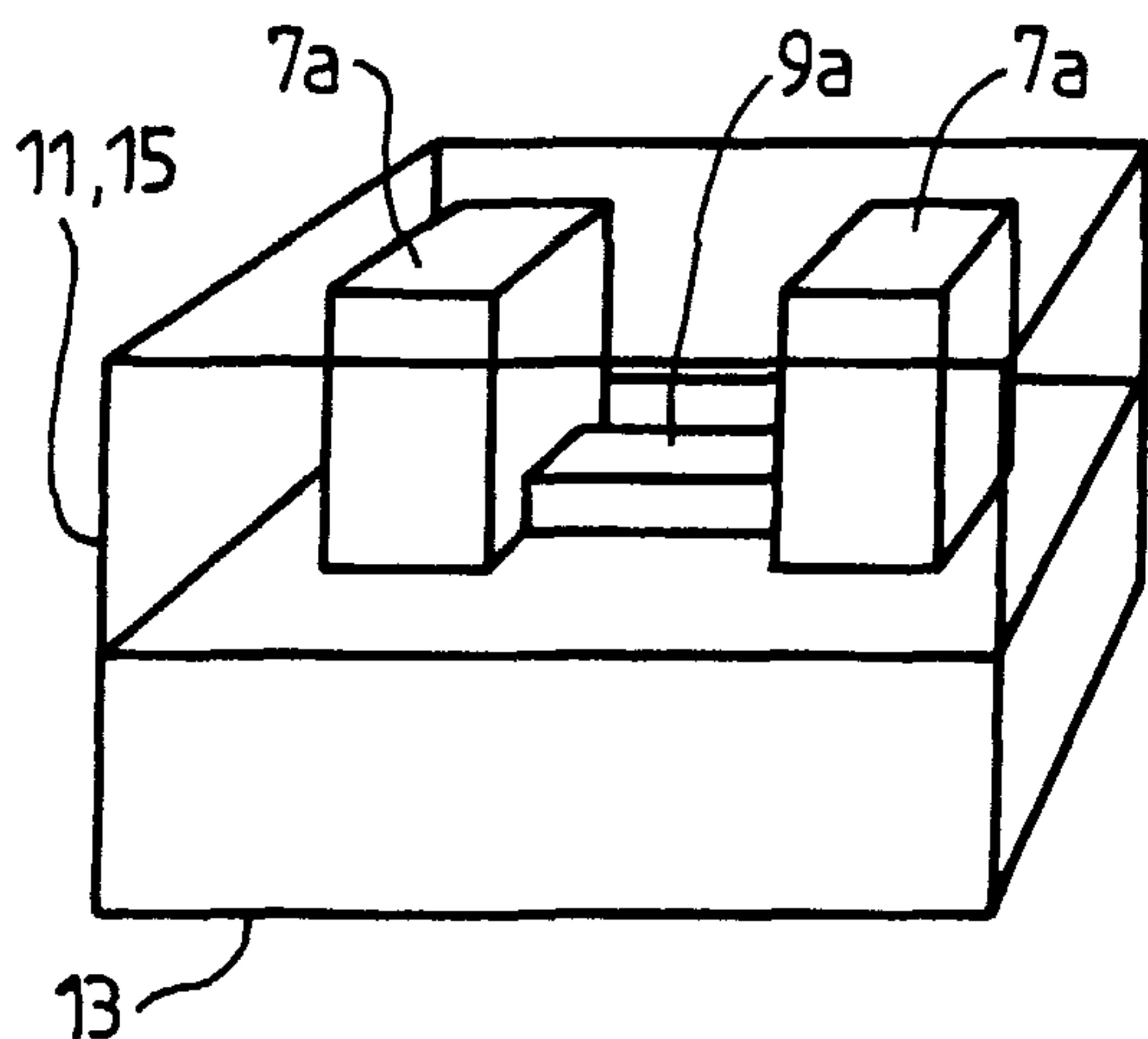

(57) Abstract: A method of manufacturing a microfluidic structure, in particular a biochip, said method consisting at least :- in manufacturing a three-dimensional micro-mould with means for defining a three-dimensional geometry including at least micro-wells and micro-grooves or micro-channels interconnecting said micro-wells ; and- in using only said three-dimensional micro-mould for molding a membrane made of a polymer material, said membrane incorporating at least said micro-wells and said micro-grooves or micro-channels, said membrane constituting a three-dimensional microfluidic structure.

WO 02/100542 A1

METHOD OF MANUFACTURING A MICROFLUIDIC STRUCTURE, IN PARTICULAR A BIOCHIP, AND STRUCTURE OBTAINED BY SAID METHOD

The present invention relates to a method of manufacturing a
5 microfluidic structure, in particular a biochip, and to a structure obtained by said method.

There is increasing interest in the biological and medical research community to integrate micromachined structures and microelectronics for biological measurements or micromanipulation. Microstructures for rapid separation and
10 isolation of cells in biological assays are of great interest for research laboratories and pharmaceutical industry. For instance, in the case of neural cultures, controlled guidance of neurons is a desired feature of a biochip for the research and understanding of complex developing neural networks.

The new field of microfluidics is turning out to be a boon for the
15 biotech industry in providing inexpensive, biologically compatible and disposable tools for handling small quantities of biological materials and chemicals. Microfluidic structures have become essential in techniques such as PCR and capillary electrophoretic cell manipulation. These microfluidic tools are often made using a variant of poly-dimethylsiloxane (PDMS) in which the channels are typically made
20 through micromoulding and placement on a glass substrate. These structures, however, are often closed structures limited to two dimensions with an input and an output end. Some more complex multi level structures can be made through stacking multiple layers of microfluidics, but these are often difficult to align and are do not offer truly micro scale alignment.

25 An object of the invention is to conceive a new microfluidic structure, in particular a biochip, said microfluidic structure having a three-dimensional geometry.

To this end, the invention provides a method of manufacturing a microfluidic structure, in particular a biochip, said method consisting at least :

- in manufacturing a three-dimensional micro-mould with means for defining a three-dimensional geometry including at least micro-wells and micro-grooves or micro-channels interconnecting said micro-wells ; and

5 - in using only said three-dimensional micro-mould for molding a membrane made of a polymer material, said membrane incorporating at least said micro-wells and said micro-grooves or micro-channels, said membrane constituting a three-dimensional microfluidic structure.

In another implementation, the method consists in completing the three-dimensional microfluidic structure by a substrate, one face of the substrate being
10 applied on one face of the membrane.

In particular, the method consists :

- in manufacturing said three dimensional micro-mould with means for defining a three-dimensional geometry including at least means for defining micro-wells and micro-grooves,

15 - in using only said three-dimensional micro-mould for molding a membrane made of polymer material, where the micro-wells are crossing the membrane, and the micro-grooves are located on one of the membrane faces and interconnecting said micro-wells, and

20 - in setting into contact said one face of the membrane and one face of the substrate in order to close one free end of the micro-wells, and to close the micro-grooves to form embedded channels interconnecting said micro-wells.

By way of example, the method consists in injecting the polymer material between the micro-mould and a plate pressed onto the top of the micro-mould, and in baking the polymer material at a temperature of about 70°C
25 during approximatively one hour, in order to form said membrane with said micro-wells crossing the membrane and said micro-grooves located on one of the membrane faces.

Advantageously, the method consists in using a polymer material having hydrophobic properties to form the membrane, and in using a substrate made
30 of a material having also hydrophobic properties, in order to obtain a natural adherence between the membrane and the substrate.

By way of example, the method consists in using a polymer material such as a polydimethylsiloxane (PDMS) to form the membrane.

Advantageously, the method consists in rendering hydrophilic the micro-wells and the micro-grooves or the micro-channels of the membrane by a
5 treatment such as an oxygen plasma treatment.

In particular, the method consists in setting in contact said membrane with a glass substrate before applying the oxygen plasma treatment, the face of the membrane in contact with the glass substrate keeping its hydrophobic properties.

10 In a first implementation, the method consists in obtaining a silicon micro-mould by an Inductive Coupled Plasma Reactive Ion Etching (ICP RIE), said etching being tri-dimensional and requiring at least a first etching to form the micro-grooves or micro-channels and a second etching to form the micro-wells.

Advantageously, in said first implementation, the method consists in
15 exposing the obtained silicon micro-mould to a CHF₃ plasma treatment in order to minimize the adherence between the surface of the obtained silicon micro-mould and the membrane to be molded in said silicon micro-mould.

In a second implementation, the method consists in obtaining a resist micro-mould by at least two successive UV exposures through a mask and without
20 intermediate developing, the first exposure defining means for forming the micro-grooves and the second exposure, after spin-coating a second resist layer, defining means for forming the micro-wells.

Advantageously, in said second implementation, said method consists in using a resist such as a SU8.

25 The invention relates also to a three-dimensional microfluidic structure as obtained by the method according to the invention.

Combination of micromachined biochips to three-dimensional structured microfluidic membranes will lead to highly parallelised bio-microsystems, capable to isolate single cells , or small groups of living cells, in an array of minimum
30 several hundreds of wells, for sensing or manipulation purposes. These so called cell-biochips have great interest for industry or for the research.

In particular, the invention is useful where a great number of parallel manipulations have to be held on living cells. The proposed three-dimensional microfluidic structure, arranging cells in an array of micro-wells, underground-connected by means of microfluidic channels may have applications for:

- 5 - Pharmacology and high output screening where highly parallelized techniques are absolutely necessary ; in the three-dimensional microfluidic structure, the open wells containing single cells are connected to underground microfluidic network which permits the addressing of pharmaceuticals products (very few products, fast, highly parallelized),
- 10 - Gene transfer, as nowadays transfection techniques are not efficient, and the cell-chip of the invention could be a key device, being capable to isolate single cells as an array for analysis and optimization of the transfection,
- ex-vivo culture and guided growth of neurons, for fundamental research, and
- 15 - cell bio-sensors (measurement of environment effects and pollution effects on cells).

Other characteristics, advantages, and details of the invention appear from the following explanatory description with reference to the accompanying drawings, given purely by way of example, and in which :

- 20 - Figure 1 is fragmentary perspective view of a three-dimensional microfluidic structure manufactured according to the method of the invention, and
- Figure 2a to 2e are schematic views for illustrating the method of the invention according to a preferred implementation.

A three-dimensional microfluidic structure 1 according to one embodiment of the invention is illustrated on figure 1.

The three-dimensional microfluidic structure 1 is formed by at least a membrane 3 and a substrate 5. The membrane 3 incorporates at least an array of vertical micro-wells 7 crossing said membrane 3, and longitudinal micro-grooves 9 located on one of the membrane faces and interconnecting at least some of said micro-

30 wells 7.

This three-dimensional microfluidic structure 1 is directly obtained by molding according to a first or second technique.

The first technique permits to obtain a silicon micro-mould, by means of deep plasma etching (ICP RIE Inductive Coupled Plasma Reactive Ion Etching). The etching has to be tri-dimensional, and at least two-levels etching are required: one for the micro-channels and one for the open wells.

Advantageously, the surface of the three-dimensional microfluidic structure is covered by a carbonic polymer, obtained by means of exposing the surface to a CHF₃ plasma, in order to minimize the adherence between the surface of the obtained micro-mould and the micro-membrane to be molded.

The second technique permits to obtain a thick resist mould, the resist used being SU8 for example. In general, at least two successive UV exposures are required through a mask, without any intermediate developing, permit to define the three-dimensional geometry of the membrane. Concretely, at least a first exposure permits to define the geometry of the micro-channels, and a second exposure, after spin-coating a second resist layer, permits to define the geometry of the micro-wells. The alignment between the two geometries can be made without developing the resist of successive layers: indeed the UV exposure changes the refraction index of exposed resist, the exposed surfaces becoming thus visible. A more complex structure could be obtained by spin-coating and UV exposing of successive layers. The total geometry of the micro-mould is then developed in a specific developer.

In particular, the method consists in a first step as illustrated on figure 2a, to spin-coat a first layer 11 of SU8 on a face of a substrate 13. The thickness of this first layer 11 is of about 20µm to 300µm, this thickness being defined by the speed and the duration of the spin-coating operation. The first layer 11 is then baked.

In a second step as illustrated on figure 2b, the first resist layer 11 is submitted to a UV exposure through a mask (not represented) to define at least the geometry 9a of the micro-grooves 9.

In a third step as illustrated on figure 2c, without developing the first layer 11, a second resist layer 15 is spin-coated on the first layer 11. The thickness of the second layer 15 is also defined by the speed and the duration of this spin-coating

operation, the thickness being of about 20 μ m to 300 μ m. The second layer 15 is then baked.

In a fourth step as illustrated on figure 2d, the second resist layer 15 is submitted to a UV exposure through a mask (non represented) for defining at least
5 the geometry 7a of the micro-wells 7.

In a final step as illustrated on figure 2e, the structure is developed in a manner known per se to obtain a three-dimensional micro-mould 20 including means for defining longitudinal micro-grooves 9 and vertical micro-wells 7. The alignment between the layers 11 and 15 is performed owing to the change of the
10 refractive index of the exposed surfaces which become visible by microscopy.

The three-dimensional micro-mould 20, obtained by one of the two methods presented, is then used to mould a membrane made of a polymer material, such as a polydimethylsiloxane (PDMS) having hydrophobic properties. The polymer (PDMS) is injected between the mould and a polyacrylic plate, pressed onto the top of
15 the mould structure. After one hour of 70°C baking, the membrane is formed: micro-wells are crossing the membrane, and micro-channels are formed on one of the membrane faces.

In a first embodiment, the micro-molded membrane can constitute a three-dimensional microfluidic structure.

20 In a second embodiment, as illustrated on figure 1, the micro-molded membrane 3 is associated with the substrate 5.

By way of example, the substrate 5 can be constituted by an electronic chip comprising at least micro-electrodes 22 which are connected to an electronic circuitry through micro-conductors 24. The micro-electrodes 22 can be
25 golded and, advantageously, the substrate 5 is made of a material having hydrophobic properties.

The membrane is directly placed onto the electronic chip, under a microscope, so that micro-wells can be aligned onto the electrodes of the electronic-chip. The membrane and the electronic-chip adhere together due to their
30 hydrophobic properties.

Advantageously, the micro-conductors 24 and the substrate 5 are transparent, in order to be able to visualize the microfluidic structure through microscopy. For instance, the substrate 5 is formed by a glass plate, and the micro-conductors 24 are in ITO.

5 In general, the materials are chosen in order to ensure the biocompatibility of the microfluidic structure with biological substances and living cells to be treated by the microfluidic structure. If the materials used do not satisfy the condition of biocompatibility, said materials are treated accordingly, i.e. with an appropriate coating.

10 Micro-wells and micro-channels have to be rendered hydrophilic, in order to permit to cells to enter into the micro-wells, and to permit to aqueous bio-chemical compounds to enter into the micro-channels. In the other hand, the micro-membrane surface facing the electronic chip has to keep its hydrophobic properties in order to keep adherence between both surfaces. For example, an oxygen
15 plasma treatment is applied to the membrane while maintaining this one stuck onto a glass substrate (different to the electronic chip substrate): the plasma penetrates and modifies the properties of micro-wells and micro-channels, rendering their surfaces hydrophilic.

In general, in a three-dimensional microfluidic structure obtained by
20 the method according to the invention, the micro-wells of the membrane have dimensions varying from 30 μm to 100 μm , the membrane has a thickness of about 40 μm to 300 μm . Furthermore, the micro-channels have a rectangular section with sizes vary from 10 μm to 300 μm , and the number of micro-wells can be comprised in a range of 100 to 10 000 / cm^2 .

25

CLAIMS

- 5 1. A method of manufacturing a microfluidic structure, in particular a biochip, said method consisting :
- in manufacturing a three-dimensional micro-mould with means for defining a three-dimensional geometry including at least micro-wells and micro-grooves or micro-channels interconnecting said micro-wells ; and
 - 10 - in using said three-dimensional micro-mould for **directly** molding a membrane made of a polymer material, said membrane incorporating at least said micro-wells **crossing** said membrane and said micro-grooves or micro-channels **interconnecting** at least some micro-wells on one of the membrane faces, said membrane constituting a three-dimensional microfluidic structure with a number of
 - 15 **micro-wells comprised in a range of 100 to 10 000/cm².**
2. A method according to claim 1, consisting in completing the three-dimensional microfluidic structure by a substrate one face thereof being applied on one face of the membrane.
3. A method according to claim 2, consisting:
- 20 - in manufacturing said three dimensional micro-mould with means for defining a three-dimensional geometry including at least means for defining micro-wells and micro-grooves,
 - in using only said three-dimensional micro-mould for molding a membrane made of polymer material, where the micro-wells are crossing the membrane,
 - 25 and the micro-grooves are located on one of the membrane faces and interconnecting said micro-wells, and
 - in setting into contact said one face of the membrane and one face of the substrate in order to close one free end of the micro-wells, and to close the micro-grooves to form embedded channels interconnecting said micro-wells.
- 30 4. A method according to any of the preceding claims, consisting in injecting the polymer material between the micro-mould and a plate pressed onto the top of the micro-mould, and in baking the polymer material at a temperature of about 70°C during approximatively one hour, in order to form said membrane with said micro-wells crossing the membrane and said micro-grooves on one of the membrane faces.
- 35 5. A method according to any of the preceding claims, consisting in using a polymer material having hydrophobic properties, in order to obtain a natural adherence between the membrane and the substrate.

6. A method according to claim 5, consisting in using a polymer material such as a polydimethylsiloxane (PDMS) to form the membrane.

7. A method according to any of the preceding claims, consisting in rendering hydrophilic the micro-wells and the micro-grooves or the micro-channels of the membrane by a treatment such as an oxygen plasma treatment.

8. A method according to claim 7, consisting in setting in contact said membrane with a glass substrate before applying the oxygen plasma treatment, the face of the membrane in contact with the glass substrate keeping its hydrophobic properties.

9. A method according to any of the preceding claims, consisting in obtaining a silicon micro-mould by an Inductive Coupled Plasma Reactive Ion Etching (ICP RIE), said etching being tri-dimensional and requiring at least a first etching to form the micro-grooves or micro-channels and a second etching to form the micro-wells.

10. A method according to claim 9, consisting in exposing the obtained silicon micro-mould to a CHF₃ plasma treatment in order to minimize the adherence between the surface of the obtained silicon micro-mould and the membrane to be molded in said silicon micro-mould.

11. A method according to any of the preceding claims 1 to 8, consisting in obtaining a resist micro-mould by at least two successive UV exposures through a mask and without intermediate developing, the first exposure defining means for forming the micro-grooves and the second exposure, after spin-coating a second resist layer, defining means for forming the micro-wells.

12. A microfluidic structure as manufactured by the method according to any of the preceding claims.

13. A microfluidic structure according to claim 12, characterized in that it comprises at least a membrane made of a polymer material and including at least micro-wells and micro-grooves or micro-channels interconnecting said micro-wells, said membrane constituting a three-dimensional micro-structure.

14. A microfluidic structure according to claim 13 characterized that it comprises also at least a substrate, one surface of said substrate being applied on a surface of the membrane.

15. A microfluidic structure according to claim 13, characterized in that said membrane is made of a polymer material.

16. A microfluidic structure according to claim 14, characterized in that said structure is transparent.

17. A microfluidic structure according to claim 15 or 16 characterized in that said membrane is made of a polydimethylsiloxane.

18. A microfluidic structure according to any of claims 13 or 17, characterized in that the micro-wells of the membrane have dimensions varying from 30 μ m to 100 μ m, in that the membrane has a thickness of about 40 μ m to 300 μ m, in that the micro-channels have a rectangular section which sizes vary from 10 μ m to 300 μ m and in that the number of micro-wells can be comprised in a range of 100 to 10 000/cm².

19. A microfluidic structure according to anyone of the claims 13 to 18, characterized in that the material(s) used for the microfluidic structure is biocompatible or rendered compatible by a specific coating, with the biological substances and living cells to be treated by said microfluidic structure.

