

(19) World Intellectual Property Organization  
International Bureau



(43) International Publication Date  
11 January 2001 (11.01.2001)

PCT

(10) International Publication Number  
WO 01/02282 A1

(51) International Patent Classification<sup>7</sup>: B67D 1/06, 3/02, G09F 23/04, 23/06

(21) International Application Number: PCT/GB00/02596

(22) International Filing Date: 6 July 2000 (06.07.2000)

(25) Filing Language: English

(26) Publication Language: English

(30) Priority Data:  
9915818.0 6 July 1999 (06.07.1999) GB

(71) Applicants and

(72) Inventors: DOUGLAS, Dennis [GB/GB]; 1 Bertrand Street, Lewisham, London SE13 7AX (GB). DOUGLAS, Kevin [GB/GB]; 1 Bertrand Street, Lewisham, London SE13 7AX (GB).

(74) Agent: STURT, Clifford, Mark; Miller Sturt Kenyon, 9 John Street, London WC1N 2ES (GB).

(81) Designated States (*national*): AE, AL, AM, AT, AU, AZ, BA, BB, BG, BR, BY, CA, CH, CN, CR, CU, CZ, DE, DK, DM, EE, ES, FI, GB, GD, GE, GH, GM, HR, HU, ID, IL, IN, IS, JP, KE, KG, KP, KR, KZ, LC, LK, LR, LS, LT, LU, LV, MA, MD, MG, MK, MN, MW, MX, NO, NZ, PL, PT, RO, RU, SD, SE, SG, SI, SK, SL, TJ, TM, TR, TT, TZ, UA, UG, US, UZ, VN, YU, ZA, ZW.

(84) Designated States (*regional*): ARIPO patent (GH, GM, KE, LS, MW, MZ, SD, SL, SZ, TZ, UG, ZW), Eurasian patent (AM, AZ, BY, KG, KZ, MD, RU, TJ, TM), European patent (AT, BE, CH, CY, DE, DK, ES, FI, FR, GB, GR, IE, IT, LU, MC, NL, PT, SE), OAPI patent (BF, BJ, CF, CG, CI, CM, GA, GN, GW, ML, MR, NE, SN, TD, TG).

Published:

— With international search report.

For two-letter codes and other abbreviations, refer to the "Guidance Notes on Codes and Abbreviations" appearing at the beginning of each regular issue of the PCT Gazette.

(54) Title: APPARATUS FOR HOLDING A BOTTLE AND ILLUMINATING THE BEVERAGE

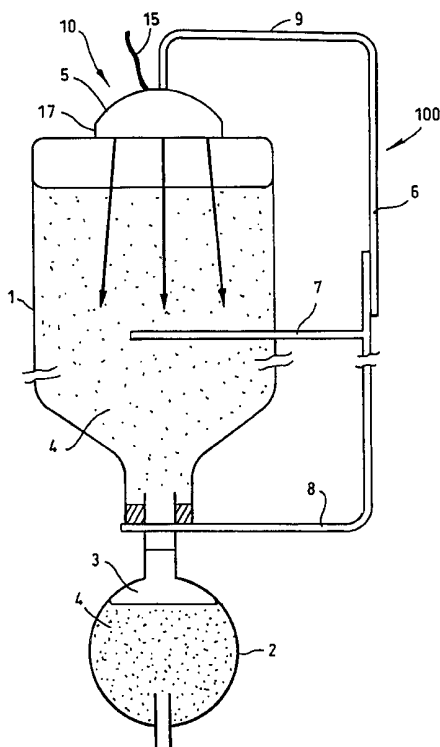

(57) Abstract: Apparatus for holding and displaying a bottle (1) in an inverted position, comprising a main support member (6) having means (8) for retaining the neck-end portion of a bottle (1) and means (5, 9) for retaining the base of a bottle (1), the means for retaining the base of a bottle comprising a cap (5), characterised in that the cap (5) is provided with a light emitting component (13) arranged to illuminate the base of a bottle (1) held by the apparatus. Also, an apparatus comprising a dispensing means (22, 23, 24) for dispensing a beverage (28) and an illuminating means (10) for illuminating at the time of dispensing the beverage (28) that has been dispensed.



WO 01/02282 A1

## APPARATUS FOR HOLDING A BOTTLE AND ILLUMINATING THE BEVERAGE

The present invention relates to an apparatus for holding and displaying a bottle, for example a bottle containing a drink, particularly a "spirit" such as whiskey, and as used with a so-called "optic" for dispensing the drink in a specific measured quantity.

It is common practice in public houses and bars to present bottles containing a spirit, cordial or other drink in an inverted position and to dispose an optic in the opening of the bottle. The optic provides a fast and convenient method of dispensing a specific measured quantity of the drink into a glass. The bottles are arranged so as to be clearly displayed to customers so as to assist in their selection of a particular drink. Thus, in addition to the convenience of the optic (which requires the bottle to be held in an inverted position), the display of the bottle is very important. The display of the bottle can help entice customers to purchase a drink such as a spirit which is more expensive than other drinks such as beer. Also, of course, the display is important for enabling customers to select between different brands and to appreciate the choice available.

It is an object of the present invention to provide an apparatus for holding a bottle which enhances the display of the bottle.

According to a first aspect of the present invention there is provided an apparatus for holding and displaying a bottle in an inverted position, comprising a main support member having means for retaining the neck-end portion of a bottle and means for retaining the base of a bottle, the means for retaining the base of a bottle comprising a cap, characterised in that the cap is provided with a light emitting component arranged to illuminate the base of a bottle held by the apparatus.

According to a second aspect of the present invention, there is provided an apparatus

for illuminating a beverage dispensed via a dispensing means, said apparatus comprising a light emitting means and an attachment means, the attachment means operably attaching the light emitting means to a dispensing means so as to enable the light emitting means to illuminate a beverage while the beverage is being dispensed by the dispensing means.

The conventional apparatus for holding an inverted bottle for use with an optic comprises a rubber cap or cup for holding the base of the bottle. This arrangement assists in the ease of replacement of the bottle when the contents thereof have been fully dispensed. In a preferred embodiment of the present invention the conventional rubber cup is replaced by a rubber cup which is not substantially larger or different in shape from the conventional component but which contains one or more light emitting diodes (LEDs) for illuminating the bottle and the content thereof. The full convenience of the conventional apparatus is maintained but the attractiveness of the display can be considerably and surprisingly enhanced.

Embodiments of the present invention will now be described by way of further example only and with reference to the accompanying drawings, in which:

Fig. 1 is a side view of a bottle, bottle holder and optic in accordance with an embodiment of the present invention.

Fig. 2 is an underside view of the bottle retaining cap shown in figure 1; and

Fig 3. is a cross-sectional view of the bottle retaining cap shown in figure 1.

Fig. 4 is a side view of a beer dispenser and a illuminating apparatus in accordance with a second embodiment of the present invention.

An embodiment of the present invention is shown schematically in figures 1 to 3 of the drawings herewith. A bottle 1 containing a drink (liquid) 4 is held in an inverted position by means of a bottle holder 100. An optic 2 is disposed in the opening of the bottle, for

measuring a quantity of the drink into a glass, by means of a transparent “measure” chamber 3.

In accordance with the common conventional apparatus, the bottle holder 100 comprises a vertical arm 6 of adjustable length (to accommodate bottles of different heights), a lower horizontal support 8, and a top horizontal support 9. Optionally, one or more horizontal arms 7 may be provided to provide for further retention of the bottle. The lower support 8 directly retains the neck-end portion of the bottle and the upper support 9 retains the base of the bottle using a rubber cap 5. The vertical arm 6 may be sprung-loaded and a bottle 1 with an optic 2 inserted in the neck thereof is mounted on the bottle holder by extending the vertical arm 6 against the force of the spring (not shown) and sliding the bottle 1 between the horizontal arms 7. A portion of the optic 2, or the rim or neck of the bottle 1, is supported by the lower horizontal support 8. The force of the spring (not shown) acting to shorten the length of the vertical arm 6 clamps the bottle in position between the upper and lower supports 8 and 9 with the resiliency of the rubber cap 5 assisting this function and accommodating for the shape of the base of the bottle which usually is not flat but has at least a slight dome shape (not shown) towards the inside of the bottle.

In the illustrated embodiment of the present invention, the cap 5 is an open-ended, flexible rubber cup which forms a housing for one or more light emitting components. As shown in figures 2 and 3, a circular printed circuit board 12 is mounted in the housing 10, for example by seating in a groove provided on the internal surface of the housing. Mounted on the circuit board 12 is at least one light emitting diode (LED) 13, three LEDs 13 being shown in the present embodiment. Resistors 11 for regulating the power supply to respective LEDs are also provided on the circuit board 12.

A reflector plate 14 is also preferably provided in the housing 10. The reflector plate

14 is disposed between the printed circuit board 12 and the open end of the cap 5 such that the resistors 11 lie between the circuit board 12 and the reflector plate 14. An aperture is provided in the reflector plate 14 for each LED 13 and the reflector plate is mounted in the housing 10 by means of a groove provided on the inner surface of the housing. The LEDs 13 protrude through the apertures. A surface coating, for example a tin coating, may be provided on at least the side of the reflector plate 14 adjacent to the base of the bottle 1. The reflector plate 14 acts to direct light from the LEDs and/or to redirect light reflected from the bottle back onto the base of the bottle. The reflector plate 14 may be planar or it may have a curved cross-section. A flange portion 17 of cap 5 extends beyond the reflector plate 14 in the direction of the open end of the cap, so as to contact the base of the bottle. Electrical cabling 15 is provided for connecting the circuit board 12 to a transformer (not shown) which is in turn connected to the mains power supply, for powering the LEDs 13. A convenient arrangement is provided by terminating the cabling 15 with a jack plug (not shown) which can be plugged into a power supply outlet adjacent the location of the bottle holder.

The majority of heat generated by in the housing 10 is generated by the resistors 11. The reflector plate 14 also serves to prevent heat generated by the resistors 11 from heating the bottle 1 and the liquid 4 therein. Rather, this heat is primarily dissipated through the rubber housing 10.

An LED socket mount 16 may be provided in each reflector plate aperture. The LED 13 is arranged to protrude through the socket mount 16, such that is surrounded and protected by the socket mount 16. The provision of the reflector plate 14 and the socket mounts 16 protects the LEDs 13 against breakage through contact with the bottle 1 or other objects and adds rigidity to the housing 10. Thus, the reflector plate 14 and socket mount 16 further enhance the safety and robustness of the apparatus.

In operation, light from the LEDs 13 is directed to the base of the bottle 1. The apparatus is particularly effective when used with a clear glass bottle containing a clear liquid. Of course, the colour of the light emitted by the LEDs can be chosen to give a desired effect. The colour can be chosen to complement or enhance the general colouring used to distinguish a particular drink or brand of drinks. In any event, the rays of light penetrating the liquid can provide a most attractive and appealing display. Needless to say, attention is particularly drawn to illuminated bottles which are clearly distinguished from unilluminated bottles. Further, a particularly striking effect is generated by the reflection and refraction of light emitted from the LEDs by air bubbles rising through the liquid in the bottle after a measure has been dispensed from the optic.

A further striking aspect of the apparatus is that it is effective not only when used with a clear glass bottle but also when used with “frosted” glass and even coloured glass bottles. In such cases, in addition to any illumination of the liquid which might be visible, the light from the LEDs appears to give the bottle a shimmering or a shiny, polished appearance.

Most notably where the name or logo associated with the drink is marked on the bottle 1, by means of a label or a frosting or etching process, the name or logo appears illuminated and thus gains in prominence in attracting the attention of a customer.

It will be apparent that the ambient lighting in public houses and bars is usually low and consequently, even with a single LED, an aesthetically pleasing, attention-drawing effect can be achieved.

The LEDs 13 are conventional and may typically each have an output of luminous intensity between 0.4 and 9 cd. Such LEDs typically require a power supply providing a current of 20 to 25 mA and have a life span of the order of 100,000 hours. The apparatus thus has a negligible power consumption, has a long life span and can be inexpensive, safe

and robust.

Conventionally, the internal light emitting element of an LED may be disposed such that the direction of strongest light emission is not parallel to the longitudinal axis of the LED. This feature can be used so that the direction of strongest emission of light forms an angle with a line normal to the surface of the circuit board 12. This angle may typically fall in the range of 8 to 45°. Thus selection of the LEDs enables adjustment of the intensity of the light emitted directly towards the bottle 1. That is, the angle of inclination is selected in accordance with the effect to be achieved.

The individual LEDs 13 may all be of the same colour, for example white or blue, or they may be of two or more colours. The colour of the individual LEDs may be selected in accordance with the colour of the bottle 1, and/or the liquid 4 and/or the label or logo on the bottle 1. For example, in the case of a clear bottle containing peach schnapps (which is a clear spirit), the LEDs 13 may be selected to impart a peach colour to the bottle 1 and the liquid 4. Thus, attention is drawn both to the illumination of the bottle 1 and its contents and to their apparent colour. Moreover, the peach colour which might naturally be used in the logo is highlighted.

Where the LEDs 13 are selected to be of differing colours, it is possible to achieve a rainbow effect in the bottle 1, particularly with the rising air bubbles when a drink is dispensed. Suitable colours for LEDs include yellow, blue, green, red, red/orange, amber and white.

Control electronics (not shown) may be provided for controlling the operation of the individual LEDs 13. The control electronics may be provided either on the circuit board 12 or, preferably, outside of the housing 10. The control electronics may be used to control the duration and timing of the light emission from the individual LEDs 13. By this means, a

number of different effects can be achieved, for example a flashing effect, the effect of changing colours, a strobe effect, a searchlight effect or a combination of effects. Moreover, switch means may be provided, operable either automatically by means of a timer or manually, for switching between different lighting effects.

A plurality of apparatuses 10 may be provided for use with a single power supply transformer and/or control electronics. The jack plug of the cabling 15 of each apparatus may be connected for example to a power supply distribution trunking which runs along a shelf to which the bottle holders are attached.

The present invention is of particular benefit where it is desired to indicate the promotion of one or more drinks and enables many novel uses. For example, in a first period of a "happy hour" one or more spirits may be sold at a discounted price, whilst in a second period of a "happy hour" other spirits may be sold at discounted prices. During the first period, the illuminating LEDs associated with bottles containing spirits to be sold at the discounted prices may be lit while those of other apparatuses are switched off. At the beginning of the second period, the illuminating LEDs associated with bottles containing the new spirits to be sold at the discounted prices may be lit while the other, previously lit, LEDs are switched off. At the end of the "happy hour" all the apparatuses may be lit or switched off. The switching means may be either automatic or manual.

Similarly, the control electronics previously described for controlling the duration and timing of the light emission from the individual LEDs 13 in a single illuminating apparatus 10 may be combined with the control electronics for controlling the operation of each apparatus. Thus, during a promotional "happy hour", all or some of the apparatuses 10 may be lit, but only apparatuses associated with promoted spirits may be controlled to provide, for example, a searchlight effect.



According to another aspect of the present invention, an illuminating apparatus 10 may be mounted for illuminating a beverage such as lager as it is dispensed from a tap 22, 23, 24. An example of such an arrangement is shown in Fig. 4, in which a beverage 28 is dispensed under gas pressure from a barrel (not shown) by means of pump through a pipe 22 and a nozzle 24 so that it is dispensed in a stream 27 into a glass 26. Control of the dispensing is achieved by means of a valve 23 which is operated by bar staff, so that the beverage 28 is either prevented from or allowed to pass through the pipe 22. Typically, the pipe 22, valve 23 and nozzle 24 are rigidly mounted on a bar in a public house and the stream 27 of beverage 28 and the glass 26 are in full view of the public when the beverage 28 is dispensed. Usually a sign 20 is disposed adjacent to the tap 22, 23, 24 to indicate the type of beverage 28 that is available to be dispensed by means of that tap. The sign 20 may be illuminated and is typically the only means by which different beverages can be distinguished from one another.

In accordance with a second aspect of the present invention, an illuminating apparatus 10 may be mounted, for example, on the pipe 22 by means of a bracket 30. Preferably, the bracket 30 is an adjustable bracket such as a ball and socket bracket. The position and mounting angle of the illuminating apparatus 10 may be adjusted so that light from the LEDs 13 is directed at either of or both the stream 27 and the glass 26. In this way, the beverage is illuminated to provide an aesthetically pleasing, eye-catching effect for consumers. Moreover, the bubbles and froth present in the beverage during and after dispensing refract the light to heighten this effect.

The illuminating apparatus may be substantially the same as the illuminating apparatus 10 described hereinabove in connection with a bottle holding apparatus. Thus, the illuminating apparatus 10 of the first and second aspects will have many or all of their

features in common. For example, the illuminating apparatus 10 of the second aspect may have one or more LEDs 13 of one or more colours, which are disposed at one or more angles to a circuit board 12.. In Fig. 4, three LEDs 13 are shown. The illuminating apparatus 10 of the second aspect may also be provided with control electronics to provide various effects, such as a searchlight effect in the glass. Additionally, two or more illuminating apparatuses 10 may be mounted to respective taps and they may be provided with centralised control electronics to provide varying effects.

Furthermore, an illuminating apparatus 10 need not be permanently switched on. Rather, a switch or other suitable connection may be provided between the valve 23 and the illuminating apparatus 10 to control whether the illuminating apparatus is turned on. Thus, the illuminating apparatus 10 may only be operational during the time a beverage 28 is dispensed. Further, a timer may be provided so that the illuminating apparatus 10 remains operational for a selected duration after the valve 23 is closed and dispensing has finished, but is then itself switched off.

Moreover, the illuminating apparatus 10 may be provided with plate 14. Plate 14 acts as a splash guard from the beverage 28 and serves to protect the LEDs 13 and the circuit board 12 from damage caused by coming into contact with the beverage. The plate 14 may be a reflector plate 14 and may be provided with a surface coating, for example a tin coating, on either or both sides. The adjustable bracket 30 serves to provide further protection for the illuminating apparatus 10 in that the mounting position and angle can be adjusted to minimise contact with the beverage 28 and to maximise the lighting effect.

Moreover, in common with the first aspect, the shape of the illuminating apparatus 10 is not restricted to a circular shape. Rather, the illuminating apparatus 10 may have an elongated rectangular or other shape to maximise lighting of both the stream 27 and the glass

26. In addition, the illuminating apparatus 10 need not be mounted on the pipe 22 but could instead be mounted in any other appropriate place adjacent to, and suitable for illuminating, the stream and/or the glass.

It is to be noted that the arrangement shown in Fig. 4 is most commonly used for dispensing lager beer, although other beverages such as soft drinks, bitter beer and stout beer may all be dispensed in this way. However, other beverage dispensing arrangements will be known to those skilled in the art, which are commonly used for dispensing other beverages and are equally included in the present invention. For example, in the case that bitter is the beverage is to be dispensed, it is common for the beverage to be dispensed using a hand operated lever pump as the valve shown in Fig. 4. In this case, the illuminating apparatus 10 could again be supported on the rigidly mounted pipe 22 using an adjustable bracket 30 for illuminating the beverage 28. Again, a connection may be provided between the lever pump and the illuminating apparatus 10 to control the operation of the illuminating apparatus 10.

It is also common for soft drinks to be dispensed using a hand held "soda gun". In such an arrangement, one or more beverages are dispensed through a hand held nozzle, which is attached to bar by means of a flexible pipe. The nozzle is provided with a handle having a number of buttons, any one of which is depressed by an operator to select and commence dispensing of a beverage through the nozzle. In such an arrangement it is not uncommon for a large number of different beverages to be dispensable through the same nozzle.

In the present invention, an illuminating apparatus 10 may be mounted on the soda gun nozzle, for example underneath or adjacent to the handle, for illuminating the beverage as it is dispensed. Again, a connection may be provided, for example between each of the buttons and the illuminating apparatus 10, to control the operation of the illuminating apparatus 10. Thus, both the time during which the illuminating apparatus 10 is switched on and the effect

to be provided by the illuminating apparatus 10 may be controlled. In this way, each different beverage dispensed by the soda gun may be illuminated by a different colour and/or with a different effect. This provides not only an aesthetically pleasing effect for consumers but also provides the operator with additional certainty that he is dispensing the correct beverage.

The foregoing description has been given by way of example only and it will be appreciated by a person skilled in the art that modifications can be made without departing from the scope of the present invention. In particular, light emitting devices other than LEDs may be used and whereas a cup-shaped cap has been described and illustrated, other arrangements may be used. The cap may for example be a flat plate with the LEDs attached thereto and, in the case in which it is used in conjunction with a bottle holder, which is spaced from and holds the base of the bottle via a plurality of legs.

## CLAIMS

1. Apparatus for holding and displaying a bottle in an inverted position, comprising a main support member having means for retaining the neck-end portion of a bottle and means for retaining the base of a bottle, the means for retaining the base of a bottle comprising a cap, characterised in that the cap is provided with a light emitting component arranged to illuminate the base of a bottle held by the apparatus.
2. An apparatus according to claim 1, further comprising a circuit board supporting the light emitting component and mounted in or on the cap.
3. An apparatus according to claim 1 or claim 2, further comprising a reflector arranged to reflect light from the light emitting component on to the base of a bottle held by the apparatus.
4. An apparatus according to any one of the preceding claims, wherein the light emitting component comprises a plurality of light emitting elements.
5. An apparatus as claimed in claims 1 to 3, wherein the cap is cup-shaped and the circuit board and reflector are mounted in the cap with the reflector being adjacent to the mouth of the cup, the reflector being provided with an aperture through which part of the light emitting component extends or through which light from the light emitting component is projected.

6. An apparatus according to any one of the preceding claims, wherein said light emitting component comprises one or more light emitting diode.
7. An apparatus according to claim 4, wherein the light emitting elements all emit light of substantially the same colour.
8. An apparatus according to any one of the preceding claims, further comprising means for electrically connecting the light emitting component to a power supply, said means including a lead terminating in a jack plug.
9. An apparatus according to any one of the preceding claims, further comprising control electronics for varying the emission of light by the light emitting component.
10. Apparatus for illuminating a beverage dispensed via a dispensing means, said apparatus comprising a light emitting means and an attachment means, the attachment means operably attaching the light emitting means to a dispensing means so as to enable the light emitting means to illuminate a beverage while the beverage is being dispensed by the dispensing means.
11. An apparatus according to claim 10, wherein the dispensing means comprises a valve for controlling the dispensing and said illuminating is actuated when the valve is operated to dispense the beverage.
12. An apparatus according to claim 10 or claim 11, wherein the light emitting means

comprises a circuit board.

13. An apparatus according to any one of claims 10 to 12, wherein the light emitting means comprises a plurality of light emitting elements.

14. An apparatus according to any one of claims 10 to 12, wherein the light emitting means comprises one or more light emitting diodes.

15. An apparatus according to any one of claims 10 to 14, wherein the apparatus further comprises a plate, the plate being provided with one or more apertures through which part of the light emitting means extends or through which the light from the light emitting means is projected.

16. An apparatus according to claim 15, wherein either one side or both sides of the plate is provided with a reflective coating.

17. An apparatus according to any one of claims 10 to 16, wherein the apparatus further comprises a housing for mounting the light emitting means.

18. An apparatus according to claim 13, wherein the light emitting elements all emit light of substantially the same colour.

19. An apparatus according to any one of claims 10 to 18, further comprising means for electrically connecting the light emitting means to a power supply, said means for electrically

connecting including a lead terminating in a jack plug.

20. An apparatus according to any one of claims 10 to 19, further comprising control electronics for varying the emission of light by the light emitting means.

21. An apparatus according to any one of claims 10 to 20, wherein the attachment means comprises an adjustable bracket.



Fig. 1.

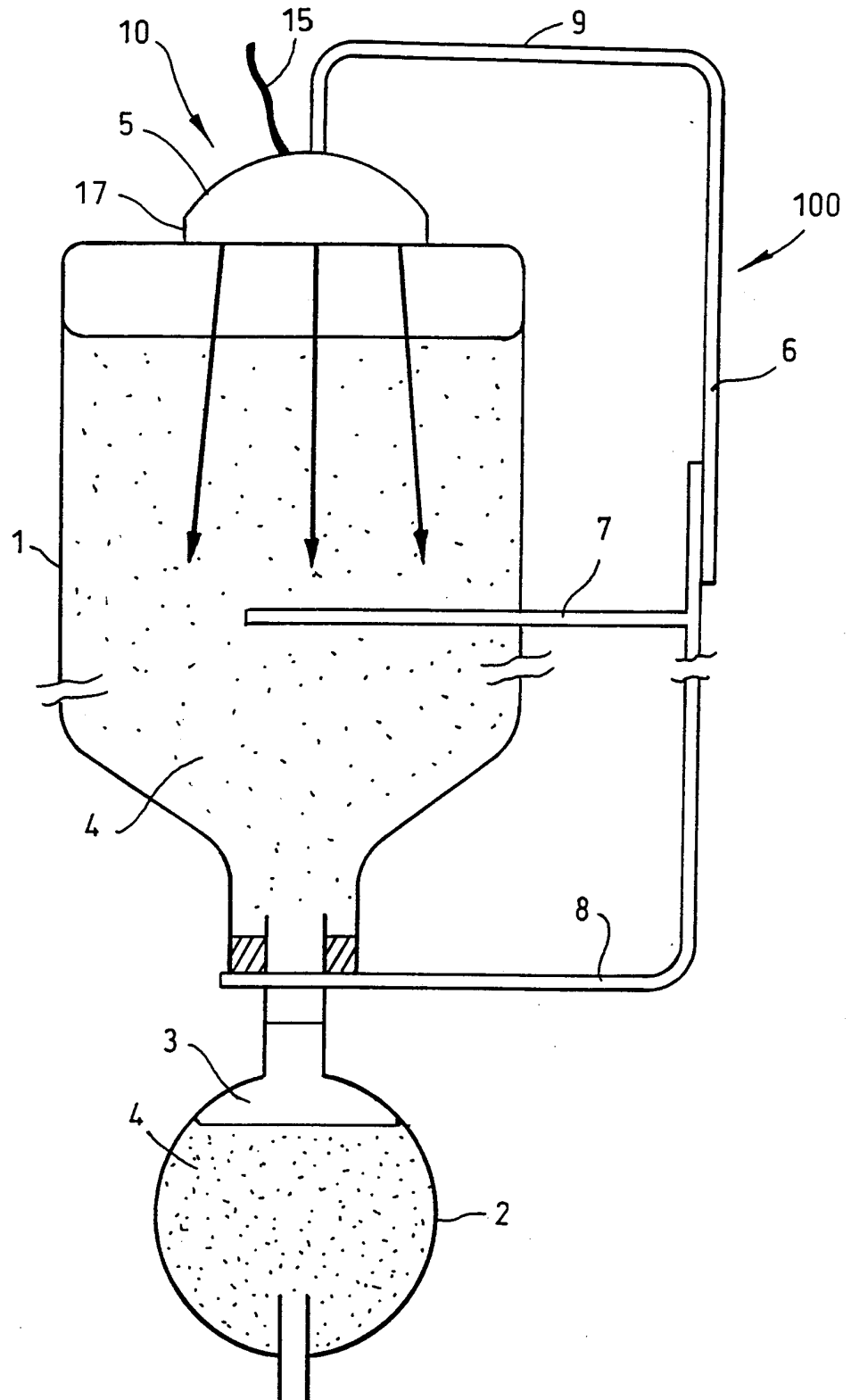

Fig.2.

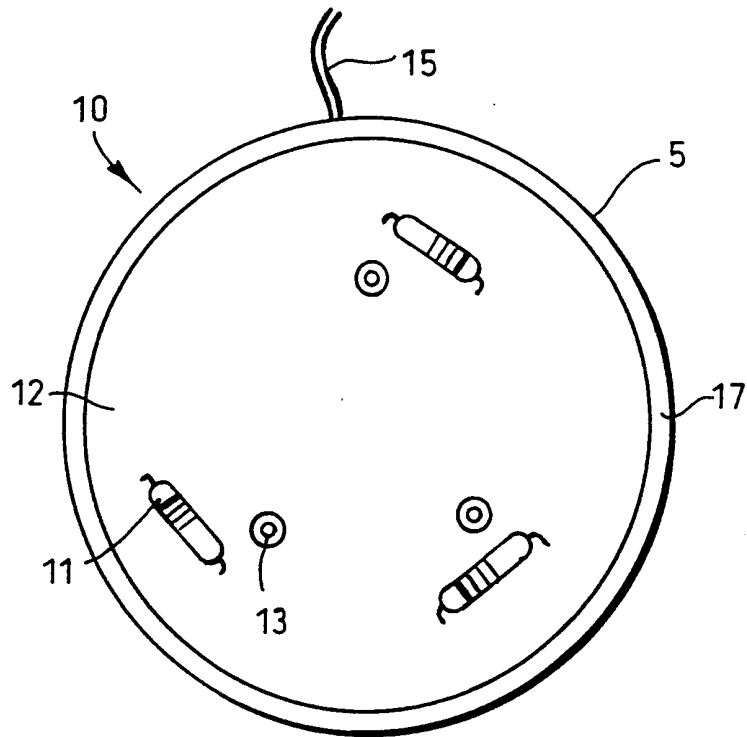

Fig.3.

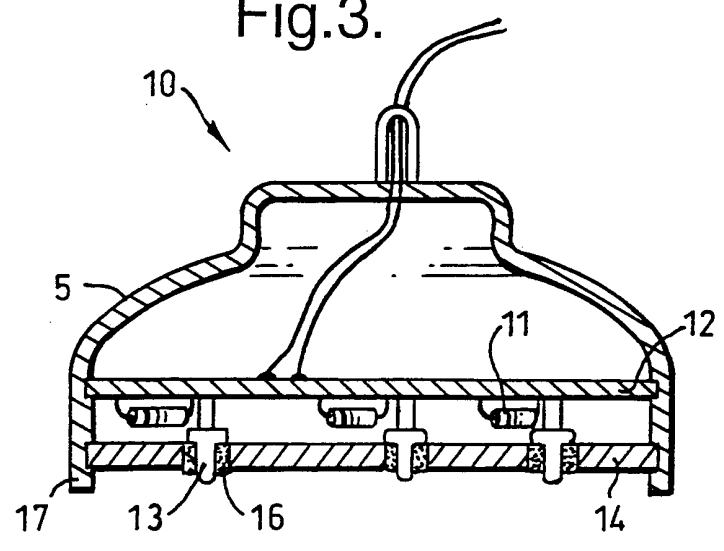
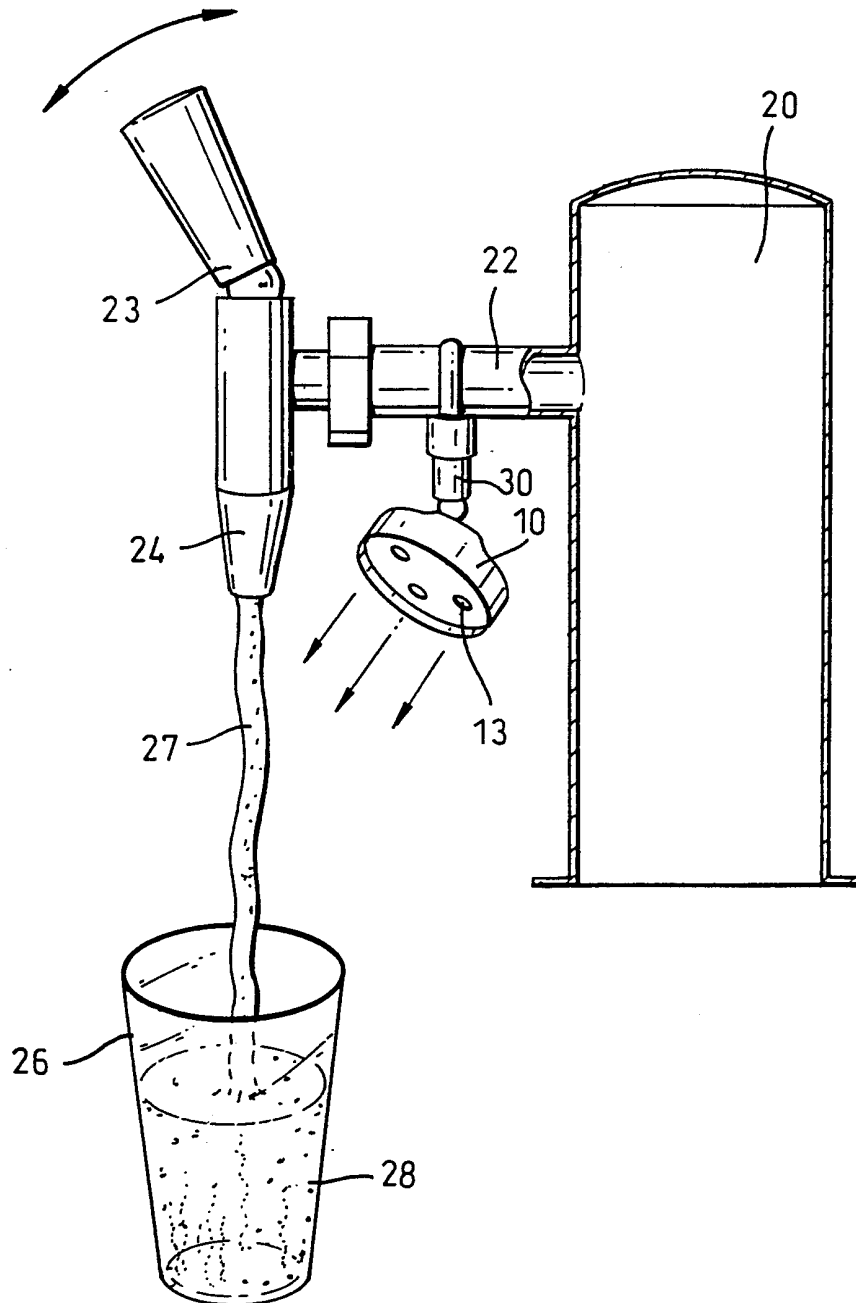

Fig.4.



# INTERNATIONAL SEARCH REPORT

International Application No  
PCT/GB 00/02596

**A. CLASSIFICATION OF SUBJECT MATTER**

IPC 7 B67D1/06 B67D3/02 G09F23/04 G09F23/06

According to International Patent Classification (IPC) or to both national classification and IPC

**B. FIELDS SEARCHED**

Minimum documentation searched (classification system followed by classification symbols)

IPC 7 B67D G09F

Documentation searched other than minimum documentation to the extent that such documents are included in the fields searched

Electronic data base consulted during the international search (name of data base and, where practical, search terms used)

EPO-Internal

**C. DOCUMENTS CONSIDERED TO BE RELEVANT**

Category *	Citation of document, with indication, where appropriate, of the relevant passages	Relevant to claim No.
X	US 5 491 617 A (CURRIE JOSEPH E) 13 February 1996 (1996-02-13) abstract; figures 1,3 ---	10-13, 15,17-21
X	US 4 426 021 A (ROSENTHAL L KENNETH) 17 January 1984 (1984-01-17)  column 1, line 53 -column 2, line 8; figure 2 ---	10,12, 15,17, 19,20
X	WO 97 26209 A (WELLS CHARLES LTD ;HODGSON STEPHEN T (IE)) 24 July 1997 (1997-07-24) page 4, line 21 - line 23; figure 1 ---	10,11, 15,17
A	US 2 746 646 A (HALL, OWEN F.) 22 May 1956 (1956-05-22) figure 2 ---	1
	-/--	

Further documents are listed in the continuation of box C.

Patent family members are listed in annex.

\* Special categories of cited documents :

- \*A\* document defining the general state of the art which is not considered to be of particular relevance
- \*E\* earlier document but published on or after the international filing date
- \*L\* document which may throw doubts on priority claim(s) or which is cited to establish the publication date of another citation or other special reason (as specified)
- \*O\* document referring to an oral disclosure, use, exhibition or other means
- \*P\* document published prior to the international filing date but later than the priority date claimed

- \*T\* later document published after the international filing date or priority date and not in conflict with the application but cited to understand the principle or theory underlying the invention
- \*X\* document of particular relevance; the claimed invention cannot be considered novel or cannot be considered to involve an inventive step when the document is taken alone
- \*Y\* document of particular relevance; the claimed invention cannot be considered to involve an inventive step when the document is combined with one or more other such documents, such combination being obvious to a person skilled in the art.
- \*&\* document member of the same patent family

Date of the actual completion of the international search

27 September 2000

Date of mailing of the international search report

06/10/2000

Name and mailing address of the ISA

European Patent Office, P.B. 5818 Patentaan 2  
NL - 2280 HV Rijswijk  
Tel. (+31-70) 340-2040, Tx. 31 651 epo nl,  
Fax: (+31-70) 340-3016

Authorized officer

Wartenhorst, F

# INTERNATIONAL SEARCH REPORT

International Application No

PCT/GB 00/02596

C.(Continuation) DOCUMENTS CONSIDERED TO BE RELEVANT		
Category °	Citation of document, with indication, where appropriate, of the relevant passages	Relevant to claim No.
A	US 1 654 841 A (SMITH H.C.) 3 January 1928 (1928-01-03) figures 2,3 -----	1

# INTERNATIONAL SEARCH REPORT

Information on patent family members

International Application No

PCT/GB 00/02596

Patent document cited in search report	Publication date	Patent family member(s)	Publication date
US 5491617 A	13-02-1996	NONE	
US 4426021 A	17-01-1984	NONE	
WO 9726209 A	24-07-1997	EP 0876293 A GB 2309295 A,B US 5967371 A	11-11-1998 23-07-1997 19-10-1999
US 2746646 A	22-05-1956	NONE	
US 1654841 A	03-01-1928	NONE	