

1 600 646

- (21) Application No. 11424/78 (22) Filed 22 Mar. 1978 (19)
- (44) Complete Specification Published 21 Oct. 1981
- (51) INT. CL.<sup>3</sup> F16H 15/50  
H02K 7/116
- (52) Index at Acceptance  
F2D 2A4 2C1A 2C1B2 2C4B2 2D3 2D5  
2D6A 2D6F 2D6Q 2D6R 2D6T 2F2A 2F2C  
H2A VA



(54) A POWER TRANSMISSION HAVING A CONTINUOUSLY VARIABLE GEAR RATIO

(71) I, HENRY TOFTDAHL OLESEN, of Danish Nationality, of 48-50 Søndergaard-svej, DK-3500 Væløse, Denmark, do hereby declare the invention, for which I pray that a patent may be granted to me and the method by which it is to be performed, to be particularly described in and by the following statement:-

5 The present invention relates to a power transmission having a continuously variable gear ratio. 5

10 Such a power transmission is shown in the specification of French patent No. 1,030,702. In this transmission the torque is transmitted by friction forces in the points of tangency between balls and runways, and two groups of balls are provided, the balls in each group rolling freely on two runways forming a respective bipartite track with other points in contact with rotating runways connected to the driving and driven shaft respectively. The two groups of balls are coupled in series through a pair of interconnected runways. Between the input runway connected to the driving shaft and the output runway connected to the driven shaft a ball bearing is interposed which must take up the large thrust necessary for transferring the useful force in the points of rolling contact. The friction of said ball bearing reduces the efficiency of the power transmission. 15

20 The present invention provides a power transmission having a continuously variable gear ratio and in which the torque is transmitted by friction forces at points of contact between balls rotatable about an axis of the transmission and runways along which the balls run during such rotation and wherein the balls and runways are divided into two groups, the balls in the two groups being coupled in parallel and each group comprising four runways, two of which are stationary or intercoupled to rotate about the axis with a fixed ratio between their angular velocities and two of which are coupled to the driving and the driven shafts respectively, the four runways being arranged such that, in cross-section they are symmetric about a radial line, a respective, radially inner, runway of each group being connected to a respective, radially inner, runway of the other group to resist relative axial movement of said radially inner runway and a respective, radially outer, runway of each group being connected to a respective, radially outer, runway of the other group to resist relative axial movement of said radially outer runways, two of the runways in each group being axially displaceable such that the relative axial displacements of the centres of the balls and the radially inner and outer runways, respectively, are the same for the two groups, the cross-sectional shapes of the runways being determined by the equations 25 30

35  $\frac{dy}{dx} = \tan u; \frac{dy}{dz} = -\tan v; \frac{dy_1}{dx} = -\tan u_1; \frac{dy_1}{dz} = \tan v_1$  35

40 and  $f = \frac{\sin u \cdot (y - \cos v)}{\sin v \cdot (y + \cos u)} = \frac{\sin u_1 \cdot (y_1 - \cos v_1)}{\sin v_1 \cdot (y_1 + \cos u_1)}$ , 40

45 where x and z represent the variable relative axial displacements of the centres of the balls and the radially outer and inner runways respectively, y and y<sub>1</sub> represent corresponding variable radial distances of the centres of the balls from the axis, u, u<sub>1</sub>, v and v<sub>1</sub> are the angles between ball radii through the points of contact between the balls and the runways 45

and the radial lines of symmetry and  $f$  is the gear ratio of the transmission.

More particularly, in the power transmission of the present invention in its preferred form, the two groups of balls and runways are arranged in parallel with the four runways of each group forming two bipartite tracks each having a radially inner and a radially outer part. The radially inner parts of the axially outer bipartite tracks of the transmission are fixedly interconnected, as also are the radially outer parts of the axially outer bipartite tracks, and two members each in contact with both groups of balls, respectively provide the runways coupled to the driving shaft and the runways coupled to the driven shaft. By this arrangement a closed structure is obtained in which all axial thrusts are taken up by the torque transmitting balls and hence are useful in effecting said torque transmission.

The gear ratio in this preferred embodiment is altered by moving the radially outer interconnected parts of the bipartite tracks in relation to the radially inner, interconnected parts of said tracks. In order to preserve contact between all of the balls and runways during said movements the shapes of the two sets of runways fulfil certain conditions which can be expressed in mathematical terms as will appear from the following exemplary description with reference to the drawings in which:

*Figures 1 and 2* show a vertical cross-section and a longitudinal section respectively of an embodiment of the power transmission according to the invention, each figure showing the movable part in two different operating positions,

*Figure 3* is a schematic longitudinal section on a larger scale showing the upper half of the torque transmitting parts of a power transmission according to the invention,

*Figure 4* is a schematic section illustrating certain geometrical conditions in a specific embodiment of the invention,

*Figure 5 (A and B)* shows calculated shapes of runway sections in position for minimum and maximum gear ratio respectively,

*Figures 6 and 7* show respective modified embodiments of the power transmission according to the invention in longitudinal section,

*Figure 8* is a cross sectional view of the embodiments shown in *Figures 6 and 7*, and

*Figure 9* shows a specific embodiment of the invention particularly suited for automobile transmissions, and

*Figures 10-13* show longitudinal sections of still further respective embodiments of the power transmission according to the invention.

The power transmission shown in *Figures 1 and 2* comprises a housing 10, to which a flanged motor 11 having a spline shaft 12 is bolted. The shaft 12 extends into the housing 10 and carries on its splined end portion an annular body 13 which engages with the splines of the shaft so as to allow axial displacement but prevent rotation of the body relatively to the shaft. The annular body 13 is provided with oppositely facing runways 14 and 15 for respective sets of balls 16 and 17 each consisting of six balls, said runways being concave and convex respectively. Surrounding the balls is a ring 20 which is also provided with a concave and a convex runway 18 and 19 respectively. Said ring 20 is secured to the outer peripheral portion of a generally cup shaped member 21, the inner, central portion of which is secured to a gear 22, which is rotatably mounted by means of a roller bearing 23 on a sleeve 24 in such a manner that said sleeve is axially displaceable relatively to the gear. Said gear 22 engages with a larger gear 25 fastened to an output shaft 26 which is rotatably mounted by means of ball bearings 27 and 28 in the walls of the housing 10. The balls 17 roll on two convex runways 29 and 31 formed on annular non-rotatable bodies 30 and 32 respectively which are secured to the inner ends of the sleeve 24 and a shaft 33 respectively, the outer end of which shaft is spline connected to a bushing 34 in the end wall of the housing 10. The balls 16 roll on two concave runways 36 and 38 formed on non-rotatable annular bodies 35 and 37 respectively which are secured to the housing 10 by means of a resilient annular plate 39 and to the inner ends of three equiangularly spaced rods 40 respectively, the outer ends of which rods are secured to a generally triangular plate 41 which in turn is secured to the outer end of the sleeve 24.

An end cap 42 having an internally threaded cylindrical skirt 43 is in engagement with external threads provided on the bushing 34 and abuts the outer end of the shaft 33 projecting from the bushing 34. The outer face of the end cap 42 is formed with a pair of recesses 44 for receiving a suitable tool by means of which the end cap can be turned to adjust the thrust of the shaft 33 and hence to the runway 31.

A cylindrical sleeve 45 having a square thread formed in its outer cylindrical face is rotatably mounted on the skirt 43 of the end cap 42. A radial flange 46 on the end cap 42 projects into a rebate 47 formed circumferentially in the inner cylindrical face of the sleeve 45 at the outer end thereof. Between the flange 46 and the bottom of the rebate 47 spring members 48 are interposed urging the sleeve 45 in friction contact with the outer face of the end wall of the housing 10. An annular collar 49 having an internal thread in engagement with the external thread of the sleeve 45 is secured to the plate 41 by means of a number of

rods 50 extending through respective openings in the wall of the housing 10. A cup shaped cover 51 with a center opening for receiving the end cap 42 is secured to the sleeve 45 by means of screws 52. The cover 51 can be rotated manually by operating a control lever 53 secured to the cover whereby the collar 49 as well as the outer runways 29 and 38 connected thereto are axially displaced. By such a displacement the position of said outer runways is altered with respect to the inner stationary runways 31 and 36, whereby the speed of rotation of the ring 20 and hence the output shaft 26 relatively to that of the input shaft 12 is varied. The instantaneous axes of rolling of the balls being indicated by dot-and-dash lines 1 and the points of tangency with the rings 13 and 20 being designated A and B respectively, the gear ratio is found from the distances of said points from the axes of rolling of the balls in proportion to the distances of the same points from the main axis  $c$ . In order to avoid sliding, of course, said relations must be identical for both sets of balls. In the embodiment shown in Figures 1 and 2 this condition has been fulfilled by the provision of concave and convex runways respectively having appropriately chosen radii of curvature, as will be further elucidated in the following with reference to Figure 3.

The necessary force of pressure on the balls is provided by two adjustable arrangements, the force acting between the outer runways 29 and 38 through the balls 16 and 17 and the intermediate ring 13 being determined by the tension of the rods 40, whereas the force acting on the balls 17 from the stationary inner runway 31 and transferred through the ring 20 and the balls 16 to the inner stationary runway 36 is determined by adjustment of the end cap 42. A uniform pressure is ensured by the resiliency of the annular plate 39 and by the inherent resiliency of the parts interconnecting the runways 29 and 38.

In the schematic sectional view of Figure 3 the balls, runways and bodies of which the latter are formed are designated by the same reference numbers as in Figure 2. Also the above mentioned points of tangency A and B have been marked in Figure 3. Additionally, in this figure the angles between radii to the points of tangency of the balls and runways have been designated by  $u$ ,  $u_1$ ,  $v$ , and  $v_1$  respectively, and the variable distances by which the outer and inner runways are displaced relatively to the balls are designated by  $x$  and  $z$  respectively. The correspondingly varying radial distances of the ball centers from the main axis  $c$  are designated by  $y$  and  $y_1$  respectively. Furthermore the angular velocities of the inner ring 13 and the outer ring 20 are designated  $\omega_1$  and  $\omega_o$  respectively. The angular velocities  $\omega_a$  and  $\omega_b$  of the bodies 32, 35 and 30, 37 respectively are zero as also indicated in Figure 3. Finally the axial distance between the ball centers is designated  $d$ , this distance being constant in view of the fact that the runways are symmetric in pairs. the condition of the uninterrupted contact between the balls and the runways is given by

$$\frac{dy}{dx} = \tan u, \quad \frac{dy}{dz} = -\tan v, \quad \frac{dy_1}{dx} = -\tan u_1, \quad \text{and}$$

$$\frac{dy_1}{dz} = \tan v_1 \quad \text{from which is obtained the relation}$$

$$\frac{\tan u}{\tan v} = \frac{\tan u_1}{\tan v_1} = \frac{dz}{dx} = g$$

by which a variable quantity  $g$  is defined.

Taking the ball radius as a unity of length, the distances from the main axis  $c$  of the points of tangency with the outer runways 19, 29 and inner runways 15, 31 on the left side of Figure 3 are  $y + \cos u$  and  $y - \cos v$  respectively. The instantaneous movement of the ball being a rotation about the points of tangency on the non-rotating runways 29 and 31, the proportion between the velocities of the points of tangency with the outer and inner rotating runways 19 and 15 respectively is equal to the proportion between the distances of said points from the instantaneous axis of rotation of the ball which is equal to

$$\frac{\sin u}{\sin v}$$

Thus the gear ratio on the left side is determined by

$$5 \quad \frac{w_o}{w_i} = f = \frac{\sin u, (y - \cos v)}{\sin v, (y + \cos u)} \quad 5$$

which for any position of adjustment must be equal to

$$10 \quad f_1 = \frac{\sin u_1, (y_1 - \cos v_1)}{\sin v_1, (y_1 + \cos u_1)} \quad 10$$

15 in order that the balls can roll without sliding in both sides of the transmission. 15

If the left-hand runway sectional curves are established,  $f$  and  $g$  are known for any  $x$  and  $z$  values belonging together, and the corresponding curves for the right-hand runways are determined by the condition that

$$20 \quad \frac{f}{g} = \frac{\frac{y}{\cos v} - 1}{\frac{y}{\cos u} + 1} = \frac{\frac{y_1}{\cos v_1} - 1}{\frac{y_1}{\cos u_1} + 1} \text{ and } \frac{\tan u_1}{\tan v_1} = g \quad 20$$

25 shall be fulfilled in any point. 25

This leads to

$$30 \quad \frac{f + g}{y_1} = \frac{g}{\cos v_1} - \frac{f}{\cos u_1} \quad 30$$

35 which may be transformed to the differential equation 35

$$40 \quad \sqrt{g^2 + \left(\frac{dy_1}{dx}\right)^2} - f \sqrt{1 + \left(\frac{dy_1}{dx}\right)^2} = \frac{f + g}{y_1} \quad 40$$

for determination of  $y_1$ , when  $f$  and  $g$  are known functions of  $x$ .

45 For positive values of  $dy_1/dx$  the given  $y$ -function forms a particular solution of the equation for the given runway curves, whereas solutions for determining the sought, corresponding runway curves must satisfy the equation with negative roots. 45

Among the innumerable runway curves that fulfil said condition an example shall be given which is distinguished by the possibility of relatively easy determination of section curves by numerical integration.

50 The shape of the convex runways is so selected that the displacements of the outer and inner runways are determined by 50

55  $x = a \tan u$  and  $z = b \tan v$ , so that: 55

$$\frac{dy}{dx} = \frac{x}{a} \frac{dy}{dz} = \frac{z}{b}, \quad y = \frac{x^2}{2a} + K_1 = K_2 - \frac{z^2}{2b},$$

60 the contents  $a$ ,  $b$ ,  $K_1$  and  $K_2$  being chosen to suit the requirements for gear ratio etc. 60

Above it has been assumed that both pairs of runway curves at one side of the transmission are determined arbitrarily, after which the outer pair of runways at the opposite side of the transmission is calculated from the differential equation

$$y_1 = F(x_1 \frac{dy}{dx} 1),$$

5 and the inner pair of runways subsequently determined by the obtained  $(x, y_1)$ -function in connection with the known relation between  $x$  and  $z$ . 5

For the sake of completeness it is noted that it is also possible, of course, to determine the  $(z, y_1)$ -function directly from the rewritten differential equation:

$$10 \quad g \sqrt{1 + \left(\frac{dy_1}{dz}\right)^2} = f \sqrt{1 + \left(g \frac{dy_1}{dz}\right)^2} = \frac{f + F}{y_1} \quad 10$$

and thereafter find the  $(x, y_1)$ -curve by use of the  $(x, z)$ -function.

15 In principle the section shape of two arbitrary runways may be chosen freely and the remaining runways be determined by the stated equations. In practice, however, it will usually be preferable to choose the runway curves at one side of the transmission and calculate the two corresponding pairs of runways as shown above. 15

20 As an example of another choice of known runways Figure 4 shows schematically an embodiment having two spherical pairs of runways consisting of internal spherical faces with the radius  $R$  at one side of the transmission and external spherical faces with the radius  $r$  at the other side. 20

In this case the condition of identical gear ratios at both sides can be expressed by

$$25 \quad \left(\frac{y}{\cos u} + 1\right) \left(\frac{Y_1}{\cos v_1} - 1\right) = rR \quad 25$$

30 which for any value of  $R = r + 2$  is satisfied for the center movement curves determined by the parametric equations: 30

$$35 \quad \begin{aligned} (x, y) &= (\sqrt{rR} - 2\sqrt{rR} \cdot F, \sqrt{1 + 2\sqrt{rR} \cdot t(tR - 1)}) \\ (z, y_1) &= (\sqrt{rR} - 2\sqrt{rR} \cdot t(tF - 1), \sqrt{1 + 2\sqrt{rR} \cdot F}) \end{aligned} \quad 35$$

in which the independent variable

$$40 \quad t = -\frac{d(z^2)}{d(x^2)} = \frac{z}{x} \cdot g = \frac{y}{x} \tan u = \frac{z}{y} \cotan v, \quad 40$$

and

$$45 \quad F = F(t) = \frac{t + 1 \ln t + C}{(t + 1)^2} \quad 45$$

The arbitrarily chosen constant  $C$  decides the possible curves in various distances from the main axis, and may be selected to suit particular requirements in respect to gear ratio etc. 50 Based on a fixed center distance in the symmetrical position,  $C$  is established by putting 50

$$55 \quad \begin{aligned} y = y_1 = a &= \sqrt{1 + 2\sqrt{rR} \cdot \frac{t_0}{t_0^2 - 1}}, \\ t_0 &= \frac{\sqrt{rR} + \sqrt{rR + (a^2 - 1)^2}}{a^2 - 1}, \quad C = \frac{2t_0}{t_0 - 1} - \ln t_0. \end{aligned} \quad 55$$

For any choice of  $C$ , and in any position, the gear ratio is given by

$$f = \frac{g}{t} \cdot \sqrt{\frac{r}{R}} = \frac{x}{z} \cdot \sqrt{\frac{r}{R}}$$

and the co-ordinates of the center movement curves mutually inter-related by the general equations:

$$\begin{aligned} 5 \quad x^2 + y_1^2 &= (r + 1)^2, \quad x^2 t^2 + y^2 &= (\sqrt{rR} \cdot t - 1)^2 & 5 \\ z^2 + y^2 &= (r + 1)^2, \quad z^2 + y_1^2 t^2 &= (\sqrt{rR} + t)^2 \end{aligned}$$

10 Center curve angles (equal to runway face angles at corresponding points) may be computed from: 10

$$\begin{aligned} 15 \quad x &= (r + 1) \sin u_1 = (\sqrt{rR} - \frac{1}{t}) \sin u & y &= (r + 1) \cos v = (\sqrt{rR} \cdot t - 1) \cos u & 15 \\ z &= (r + 1) \sin v = (\sqrt{rR} + t) \sin v_1 & y_1 &= (r + 1) \cos u_1 = (\frac{\sqrt{rR} z}{t} + 1) \cos v_1 \end{aligned}$$

20 Thus, the co-ordinates of the sought outer runways are given by the parametric presentation: 20

$$\begin{aligned} 25 \quad X &= x - \sin u = \frac{(\sqrt{rR} - 1)t - 1}{\sqrt{rR} \cdot t - 1} \cdot \sqrt{rR - 2\sqrt{rR} \cdot F} & 25 \\ Y &= y + \cos u = \frac{\sqrt{1 + 2\sqrt{rR} \cdot t(tF - 1)}}{1 - \frac{1}{\sqrt{rR} \cdot t}} \end{aligned}$$

30 and, for the inner runways: 30

$$\begin{aligned} 35 \quad Z &= z + \sin v_1 = \frac{\sqrt{rR} + 1 + t}{\sqrt{rR} + t} \cdot \sqrt{rR - 2\sqrt{rR} \cdot t(tF - 1)} \\ Y_1 &= y_1 - \cos v_1 = \frac{\sqrt{1 + 2\sqrt{rR} \cdot F}}{1 + \frac{1}{\sqrt{rR}}} \end{aligned} \quad 35$$

40 For geometrical construction of runway curvatures it may be noticed that the length of the perpendicular to the runway face in point (X, Y) from said point to the point of crossing with the main axis equals  $\sqrt{rR} \cdot t$  while the projection on the axis of same perpendicular's section from ball center to the axis is  $x \cdot t$ , and analogous for point (Z, Y<sub>1</sub>) with reciprocal values of t, as indicated on the figure. 40

45 Figure 5, A & B show the actual shapes of runway pairs computed from the above equations selecting  $r, R = 2, 4$  and  $C = 3.08$ , and putting  $t_{\max} = 1.81$  and  $t_{\min} = 1.08$  respectively. 45

50 In the embodiment of Figures 1 and 2 the axially outer pair of runways at each side are stationary whereas the rotating movement is transferred from an radially inner pair of runways with the angular velocity  $\omega_i$  to an radially outer pair of runways with the angular velocity  $\omega_o = f \cdot \omega_i$ . However, there is nothing to prevent choice of other combinations of stationary and rotary pairs of runways, the relative rotations being generally determined by the relation 50

$$55 \quad \omega_o - \omega_b = f(\omega_i - \omega_a) \quad 55$$

60 using the designations shown in Figure 3. If, for example, the intermediate pairs of runways are linked by a toothed gearing allowing axial displacement, so that  $\omega_i = \omega_o$ , and  $\omega_a = 0$  is chosen, then 60

$$\omega_b = (1 - f)\omega_i$$

which shows that the gear ratio from a shaft connected to the intermediate pairs of runways to the axially and radially outer runways can be regulated down to zero, if  $f_{\max}$  is brought up to 1 (whereby lines through the points of tangency intersect on the main axis  $c$ ).

5 The variable power transmission according to the invention can be combined with planet gears in various ways whereby particular properties may be obtained. 5

A simple structure of this type is shown in Figures 6 and 8, in which the input and output shafts as well as the torque transmitting balls and annular bodies cooperating therewith are designated by the same reference numbers as the corresponding parts in Figures 1 and 2.

10 The overall gear mechanism is enclosed in a gear box 54 provided with internal teeth 55 with which three planet gears 56 are in engagement. The journals 57 of said planet gear are carried by the unit constituted by the outer runway bodies 30 and 37 which is so mounted as to be axially displaceable but not rotatable with respect to the unit constituted by the inner runway bodies 32 and 35. In engagement with the planet gears 56 is also a sun gear constituted by external teeth 58 on the ring 20 on which the driven runways are formed. The ring 20 is freely displaceable and rotatable. The annular body 13 on which the driving runways are formed is slidingly, but non-rotatably mounted on the input shaft 12. The body 13 can be displaced by operation of a control lever 59, which extends through a helical slot 60 in the gear box and activates a sleeve 61 carrying the body 13 through a ball bearing 62. The axial position of the annular body 13 determines the gear ratio of the transmission. 15

20 The inner runway bodies 32 and 35 being secured to the output shaft 26 and the planet carrier 30, 37 being non-rotatably connected to the output shaft, the overall gear ratio of the transmission will be 20

$$25 \quad f_t = \frac{s \cdot f}{s \cdot f + p} \quad 25$$

30 where  $s$  and  $p$  are the numbers of teeth on the ring 20 and in the gear box 54 respectively, whereas  $f$  is the gear ratio between the inner ring 13 and the outer ring 20 in the case when the outer runway bodies 30 and 37 are held against rotation (in which case the gear box 54 would rotate in the opposite direction with the speed of rotation  $sf/p$  relatively to the input shaft). 30

35 If so desired, of course, the direction of power flow through the transmission may be reversed, so that the shaft 26 is used as input shaft and the shaft 12 as output shaft. 35

Whereas in the embodiment of Figure 6 the variation of the gear ratio  $f_t$  is reduced as compared with the variation of  $f$ , Figure 7 shows a power transmission in which the friction gear is combined with a double planet gear in such a manner that the gear ratio variation can be increased as desired by appropriate choice of the gear ratio of one planet gear, the sun gear 63 of which is slidingly but non-rotatably mounted on the input shaft 12 being 40 fixedly connected with the sleeve 61 carrying the inner ring 13. In Figure 7 the same reference numbers as in Figure 6 have been used for similar parts. The ring gear 64 of the latter planet gear is formed on the inner cylindrical wall of the gear box 54, and the planet gear wheels 65 are supported by journals 66 which are fixed to the structure comprising the inner runway bodies 32 and 35. Thus the axially outer runways are rotated with a constant angular speed relatively to the input shaft 12. The output shaft 26 is fixedly connected to an internally toothed ring 67, the teeth 68 of which are in engagement with the planet gear wheels 56 carried by the runway bodies 30 and 37. 45

50 The overall gear ratio of this power transmission is determined by 50

$$55 \quad f_q = \frac{e - sf}{p + e} \quad 55$$

55 where  $e$  is the number of teeth of the sun gear wheel 63 on the input shaft 12, the stationary ring gear 64 having the same number of teeth  $p$  as the rotating ring gear 67, 68. 55

60 If  $f$  can be varied from  $f_{\min}$  to  $f_{\max}$  and a variation of the speed of the output shaft from standstill to maximum number of revolutions in the direction of the input shaft is required,  $e = s \cdot f_{\max}$  is selected, whereas  $e = s \cdot f_{\min}$  is used, if variation from standstill to full speed in the opposite direction is required. In both cases  $f_q$  will be variable from 60

$$0 \text{ to } f_{q \max} = \frac{s}{p + e} (f_{\max} - f_{\min}).$$

By choosing an intermediate size of the number  $e$  the rotation of the output shaft can be varied from a given number of revolutions in one direction via standstill to a given number of revolutions in the opposite direction. If, for example,

$$e = \frac{s}{2} \cdot (f_{\max} + f_{\min}) \quad 5$$

is chosen, the gear ratio can be varied between 10

$$\pm \frac{s}{2(p + e)} \cdot (f_{\max} - f_{\min})$$

The section shown in Figure 8 is common to the structures shown in Figures 6 and 7, the planet gear wheels 65 which are only present in the latter embodiment being shown in dotted lines in Figure 8. 15

In the embodiment of Figure 9 the axially outer runway bodies 32 and 35 are fitted on the input shaft 12, whereas the axially inner double runway bodies 13 and 20 are freely displaceable axially but coupled for joined rotation by splines 77. The annular body 20 is provided with teeth 58 in engagement with planet gears 56, the journals of which are fixedly positioned at the body 30, 37 carrying the outer runways and being rotatable in same direction as the input shaft rotates, but held against reverse rotation by a one-way stop device 69, and axially displaceable by actuation of a non-rotatable ring member 70 connected to an external ring 71 through pins 72. The planet gears 56 also engage with the teeth 68 of an internally toothed gear wheel 67 on the output shaft 26. 20

The numbers of teeth on the gear 67 and the member 20 being  $p$  and  $s$  respectively, the gear ratio is determined by 25

$$\frac{\omega_i}{\omega_o} = \frac{p}{s} \left( \frac{1}{f} - 1 \right) = -\frac{1}{F} \quad 30$$

Choosing  $f_{\max} = \frac{p}{p + s}$  results in  $F_{\max} = 1$ , 35

involving that the torque will be transmitted directly through the gear mechanism so that no reaction momentum will be transferred to the ring 70. Operating in this position, therefore, the member 30,37 may rotate freely at any speed with no influence on the 1:1 transmission from input to output shaft, and may as well revolve with the speed identical to that of the said shafts, in order to eliminate wear and energy loss in the gear system. 40

The synchronous rotation of the entire gear (the housing 54 being the only exception) is ensured by a friction coupling consisting of a cone 73 on the member 35 which in the  $f_{\max}$ -position engages with a conical surface 74 on the member 37. 45

At any gear ratio different from the direct transmission occurring for  $f = f_{\max}$  the torque conversion will induce a reverse momentum on the ring member 70 through the back stop device 69, while the balls and gears will co-operate in rotating the output shaft at reduced speed compared to the input shaft. 50

In Figure 9 the runway curvature is based on the double spherical design shown in Figure 4 and 5, giving  $f_{\min} \approx 1/3$  and  $f_{\max} \approx 2/3$ . Thus, with  $p/s = 2$  the resulting gear ratio varies from  $F_{\min} = 1/4$  to  $F_{\max} = 1/1$ . Such range of gear ratios is suitable for automobile transmissions where the advantage of eliminated wear and energy losses can be turned to account during the gear part of driving hours when no gearing down is required. 55

If, in Figure 9, the housing 54 is removed, and the gear wheel 67 held against rotation, the member 30, 37 will rotate in the reverse direction relative to the shaft 12, the gear ratio being

$$- F_1 = \frac{p}{sf} - \frac{p + s}{s}$$



Thus, the gear ratio  $F_1$  equals zero when

$$f = \frac{P}{p + s}$$

causing non-rotation of the shaft 12 if employed as output (and extended to the right) with the unit 30, 37 connected to the input shaft.

Figure 10 shows a gear motor having stator windings 75a mounted on the inner cylindrical wall of a housing 76 and rotor windings 75b mounted on a generally cylindrical member 78 comprising annular runway bodies 30 and 37 like those shown in Figures 2 and 3. The gear motor further comprises stationary annular runway bodies 32 and 35 as well as intermediate runway rings 13 and 20 and balls cooperating with said bodies and rings in a manner similar to that described in connection with Figures 1-3. However, in the present structure the inner ring 13, which is splined to the motor shaft 79 and is axially displaceable thereon by means of a control lever 74 and a screw mechanism 80, 81, is also coupled to the outer ring 20 through splines 77, so that said rings 13 and 20 and shaft 79 rotate with the same velocity relatively to the rotor as determined by the gear ratio  $\frac{1}{1-f}$ .

If the cylindrical member 78 instead of being part of the rotor of an electromotor is coupled to a shaft (not shown) and the direction of powertransmission is reversed, then  $f = 1$  will correspond to non-rotation of the output shaft. Thus the speed of rotation of the output shaft can be varied continuously from zero to a maximum value or between two values on either side of the zero point.

Figure 11 shows a longitudinal section through a power transmission based on the abovementioned principle, with all parts similar to previously described embodiments designated with reference numerals identical to those formerly used. The upper portion of the figure illustrates the zero-rotation position of runways, whereas underneath the main axis the transmission is shown in its maximum speed position.

The gear ratio is varied by turning a worm spindle 82 in engagement with teeth at the circumference of an annular collar 83 having external thread in engagement with the internal thread of a sleeve 84 fastening to the housing 10. The axial displacement of the collar 83 is transmitted to the outer runway carrying body 30, 37 through a ball bearing 62 and a pinion gear 22 fixedly connected to the said body. The pinion gear 22 is in engagement with the gear wheel 25 fitted on the output shaft 26, the revolutions of which thus can be varied infinitely from zero to maximum speed.

An increase of the range of variation can be obtained by providing a double set of runways. Figure 12 shows such a structure comprising three intermediate runway rings which are interconnected through splines 85 and 86 and are freely rotating with a common angular velocity  $\omega_2$ , and annular bodies 87 and 88 which are fixed to the housing 89 and formed with axially outer, radially intermediate, stationary runways. Letting  $f$  and  $F$  be the gear ratios determined by the inner and outer ball sets respectively, the overall gear ratio, i.e. the ratio between the angular velocity  $\omega_3$  of the generally cylindrical member 90 and the angular velocity  $\omega_1$  of the shaft 12 is found to be

$$F_2 = \frac{\omega_3}{\omega_1} = \frac{1-F}{1-\frac{1}{f}}$$

It is noted that this gear ratio is negative corresponding to reversal of the direction of rotation when  $f < 1$  and  $F < 1$ . If the runways are so arranged that  $F$  increases with decreasing  $f$ , the resulting variation becomes large, even if  $f$  and  $F$  vary only relatively little individually, for example from 0.5 to 0.75 in which case  $\omega_3$  varies from  $-0.25 \omega_1$  to  $-1.5 \omega_1$ , i.e. in the proportion 1:6 as compared to the proportion 1:1.5 for  $f$  and  $F$ .

In Figure 13 a modification of the power transmission described in connection with Figures 1 and 2 is shown. Parts corresponding to those of the latter structure have been designated with the same reference numerals as used in said figures. In the embodiment of Figure 13 the non-rotatable shaft 33 is provided with oppositely directed helical grooves 91 and 92 in which balls 93 and 94 respectively are received which are also in engagement with corresponding helical grooves 95 and 96 formed in the bore of the runway ring 32 and the sleeve 24 respectively. A projection 97 on the plate 41 is connected to one end of a tension spring 98 the opposite end of which is connected to the housing 10, so that the spring counteracts the torque transmitted to the runway bodies 30 and 37. In this arrangement an increase of the torque affecting the ring 32 in one direction will cause an increased axial thrust on the ring whereby the pressure acting between the ball and the ring runway is also

increased. In a similar way the ball-and-groove coupling between the shaft 33 and the sleeve 24 connected with the spring loaded runway bodies 30 and 37 will cause automatic adjustment of the gear ratio in dependence of the transmitted torque.

In another arrangement for automatic load controlled variation of the gear ratio the cylindrical sleeve 45, Figure 2, is secured to the shaft 33 carrying the runway body 32, and said shaft 33 is made rotatable against the action of a spring. The torque transmitted to the runway body 32 being always half the torque of the input shaft 12, an automatic control of the gear ratio can be obtained by suitable choice of the spring torque.

Many modifications of the devices shown and described above can be made within the scope of the invention.

In the preceding calculations all equations have been derived from the assumption of equal size of the two sets of balls, using the radius as unit of length.

There is, however, nothing to prevent the employment of different diameters for the two sets of balls, if the formulas for computation of runway cross sections are amended correspondingly.

As an example it can be mentioned that in the embodiment of two runway pairs being spherical, having external radius  $r$  at one side and internal radius  $R$  at the other side, and ball diameters  $D$  and  $D_1$  for the two sides respectively, the remaining pairs of runways are determined by the cross section shapes given by the parametric presentation:

$$X = \left(1 - \frac{1}{2A/D^2 - 1/t}\right) \cdot \sqrt{R(R - D_1) - AF}$$

$$Y = \frac{\sqrt{D^2/4 + At(tF - 1)}}{1 - D^2/2AT}$$

$$Z = \left(1 + \frac{1}{2A/D_1^2 + t}\right) \cdot \sqrt{r(r + D) - At(tF - 1)}$$

$$Y_1 = \frac{\sqrt{D_1^2/4 + AF}}{1 + D_1^2 t/2A}$$

$$\text{in which } A = D\sqrt{R(R - D_1)} \text{ and } F = F(t) = \frac{t + 1nt + C}{(t + 1)^2},$$

while  $D$ ,  $D_1$ ,  $r$  and  $R$  may be chosen arbitrarily with the only limitation that  $R/D_1 - r/D = 1$ .

The gear ratio is for any choice of constants expressed by

$$f = \sqrt{\frac{r(RrD_1 - ADF)}{R(RrD - AD_1 t(tF - 1))}}$$

WHAT I CLAIM IS:

1. A power transmission having a continuously variable gear ratio and in which the torque is transmitted by friction forces at points of contact between balls rotatable about an axis of the transmission and runways along which the balls run during such rotation and wherein the balls and runways are divided into two groups, the balls in the two groups being coupled in parallel and each group comprising four runways, two of which are stationary or intercoupled to rotate about the axis with a fixed ratio between their angular velocities and two of which are coupled to the driving and the driven shafts respectively, the four runways being arranged such that, in cross-section they are symmetric about a radial line, a respective, radially inner, runway of each group being connected to a respective, radially inner, runway of the other group to resist relative axial movement of said radially inner runways and a respective, radially outer, runway of each group being connected to a respective, radially outer, runway of the other group to resist relative axial movement of said radially outer runways, two of the runways in each group being axially displaceable such that the relative axial displacements of the centres of the balls and the radially inner and outer runways, respectively, are the same for the two groups, the cross-sectional shapes

of the runways being determined by the equations

$$5 \quad \frac{dy}{dx} = \tan u; \quad \frac{dy}{dz} = -\tan v; \quad \frac{dy_1}{dx} = -\tan u_1; \quad \frac{dy_1}{dz} = \tan v_1 \quad 5$$

$$10 \quad \text{and } f = \frac{\sin u \cdot (y - \cos v)}{\sin v \cdot (y + \cos u)} = \frac{\sin u_1 (y_1 - \cos v_1)}{\sin v_1 (y_1 + \cos u_1)}, \quad 10$$

where x and z represents the variable relative axial displacements of the centres of the balls and the radially outer and inner runways respectively, y and  $y_1$  represent corresponding variable radial distances of the centres of the balls from the axis, u,  $u_1$ , v and  $v_1$  are the angles between ball radii through the points of contact between the balls and the runways and the radial lines of symmetry and f is the gear ratio of the transmission. 15

2. A power transmission according to claim 1, characterized in that the runways in one group are concave, whereas the runways of the other group are convex.

3. A power transmission according to claim 1 or 2, characterized in that the runways of the two groups are formed on three axially spaced pairs of annular bodies, the bodies of each pair being spaced radially, each of the middle bodies being provided with two opposite runways. 20

4. A power transmission according to claim 3 and comprising a stationary housing, in which the balls and runway bodies are mounted, characterized in that the radially inner, axially outer bodies are firmly connected to said housing, that the radially inner middle body is slidingly, but non-rotatably mounted on the driving shaft of the transmission, and that the radially and axially outer bodies are interconnected and jointly displaceable, but non-rotatable, the radially outer middle body being geared to the driven shaft. 25

5. A power transmission according to claim 3 and comprising a housing in which the balls and runway bodies are mounted, characterized in that the axially outer bodies are firmly connected to the driven shaft, that the radially inner middle body is slidingly, but non-rotatably mounted on the driving shaft, and that the radially outer middle body is freely rotatable and displaceable, said latter body being provided with external teeth slidingly engaging with teeth on a number of planet gears carried by the outer bodies assembly and further engaging with internal teeth provided on the inner wall of said housing. 30

6. A power transmission according to claim 3 and comprising a housing, in which the balls and runway bodies are mounted, characterized in that the axially outer bodies are firmly interconnected and carry two sets of planet gears, one of which is in engagement with a sun gear firmly connected to the radially inner middle body and slidingly, but non-rotatably mounted on the driving shaft, as well as with a ring gear provided on the inner wall of said housing, the second set of planet gears engaging with external teeth on the radially outer middle body, which is freely displaceable, and with a ring gear which is firmly mounted on the driven shaft. 40

7. A power transmission according to claim 3, characterized in that the radially inner, axially outer bodies are mounted on the driving shaft, and that the middle bodies are freely displaceable and coupled for joint rotation, the radially outer middle body being provided with teeth in engagement with planet gears carried by the radially and axially outer bodies, which are displaceable and jointly rotatable in the same direction as the driving shaft, but prevented from rotating in the opposite direction, said planet gears further engaging with a ring gear on the driven shaft. 45

8. A power transmission according to claim 7, characterized in that a friction coupling is provided between one of the radially inner, axially outer bodies and the correspondingly radially and axially outer body, which friction coupling is adapted to engage when the transmission is adjusted to maximum gear ratio. 50

9. A power transmission according to claim 3 and having a housing, in which the balls and runway bodies are mounted, characterized in that the transmission forms part of a gear motor having stator windings mounted on the inner wall of said housing and rotor windings mounted on the interconnected radially and axially outer runway bodies, the radially inner, axially outer bodies being firmly connected to the housing and the radially inner middle body being displaceably, but non-rotatably mounted on the shaft of the gear motor and slidingly, but non-rotatably connected to the radially outer middle body. 55

10. A power transmission according to claim 3 and having a stationary housing, in which the balls and runway bodies are mounted, characterized in that the radially inner, axially outer bodies are firmly connected to the housing, that the radially inner middle body 60

is firmly mounted on the driving shaft and is slidingly, but non-rotatably connected to the radially outer middle body, and that the radially and axially outer bodies are interconnected and jointly displaceable, said latter bodies being further geared to the driven shaft.

5 11. A power transmission according to claim 3, characterized in that each group further  
comprises a second set of balls and associated runways which surround the balls and  
runways of the first set, radially inner runways of said second set being firmly connected to  
the radially outer runways of the first set. 5

10 12. A power transmission according to claim 11 and comprising a stationary housing in  
which the balls and runway bodies are mounted, characterized in that the radially inner,  
axially outer bodies are firmly mounted on the driving shaft, that the radially middle, axially 10  
outer bodies are firmly connected to the housing, that the axially middle bodies are  
slidingly, but non-rotatably interconnected and as a whole are freely displaceable and  
rotatable, and that the radially and axially outer bodies are interconnected.

15 13. A power transmission according to claim 4, wherein one of the radially inner,  
axially outer runway bodies is mounted on a stationary shaft which is mounted coaxially 15  
with the driving shaft, and wherein a sleeve firmly connected with the radially and axially  
outer bodies is slidingly mounted, characterized in that said stationary shaft is provided with  
oppositely handed helical grooves cooperating with corresponding grooves in the bores of  
said radially inner, axially outer runway body and said sleeve respectively to form  
substantially closed channels, in which balls are received, and that a radially extending arm 20  
fixed to said sleeve in under the influence of a spring, which counteracts the torque  
transmitted to the radially and axially outer bodies. 20

25 14. A power transmission according to any of the preceding claims, characterized in  
that spring means are provided to urge one or more of the axially outer runways towards the  
balls. 25

15. A power transmission substantially as herein described with reference to Figures 1  
and 2, Figure 3, Figure 4, Figure 5a, Figure 5b, Figure 6 or 7 with Figure 8, Figure 9, Figure  
10, Figure 11, Figure 12 or Figure 13 of the accompanying drawings.

30 R.G.C. JENKINS & CO.,  
Chartered Patent Agents,  
Chancery House,  
53/64 Chancery Lane,  
London WC2A 1QU.  
35 Agents for the Applicant. 35

Fig. 1.

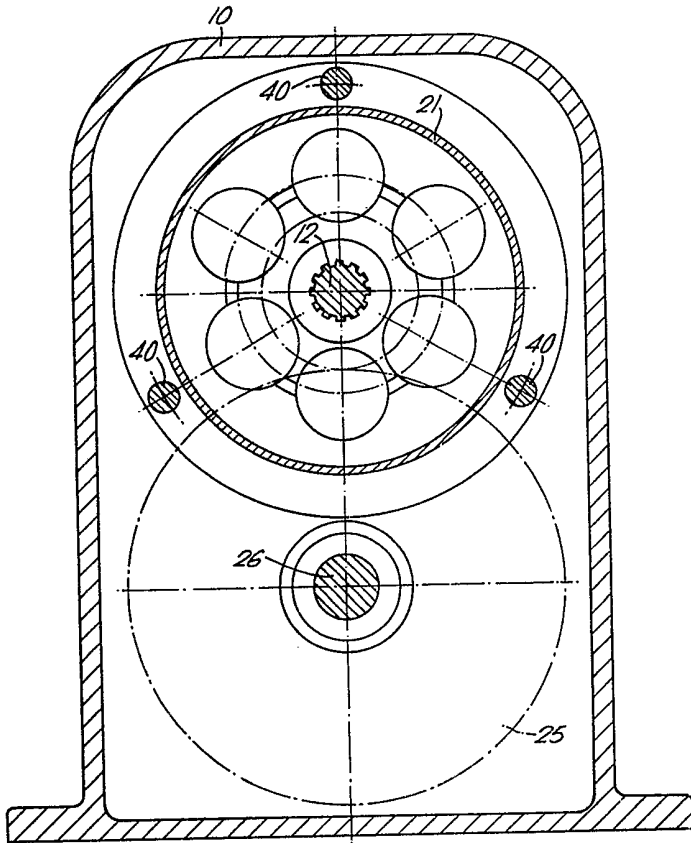
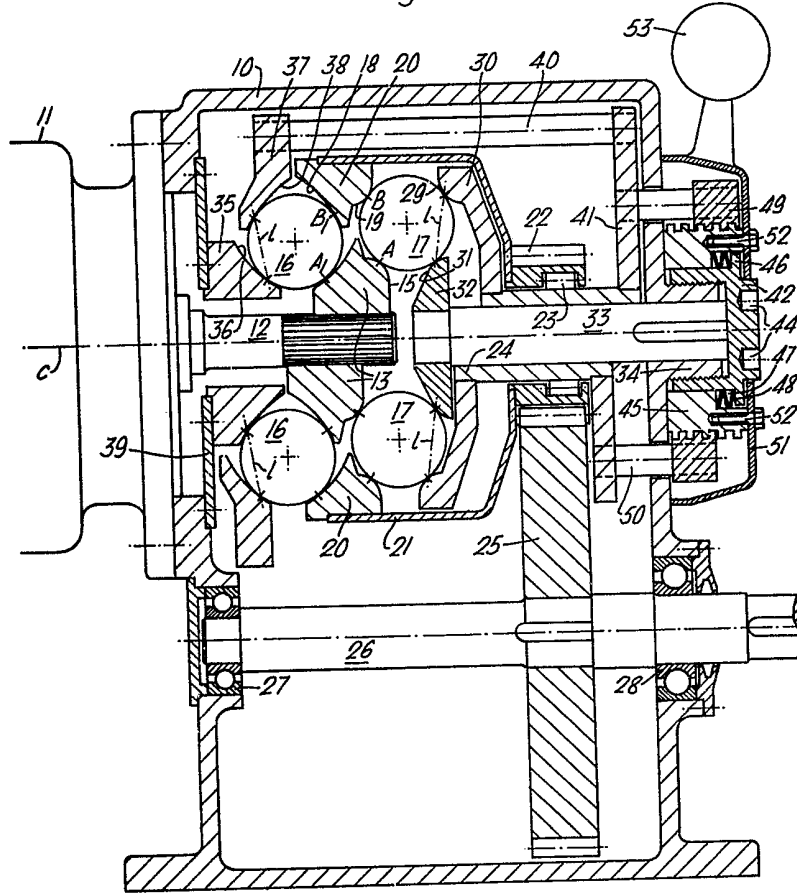

Fig. 2.



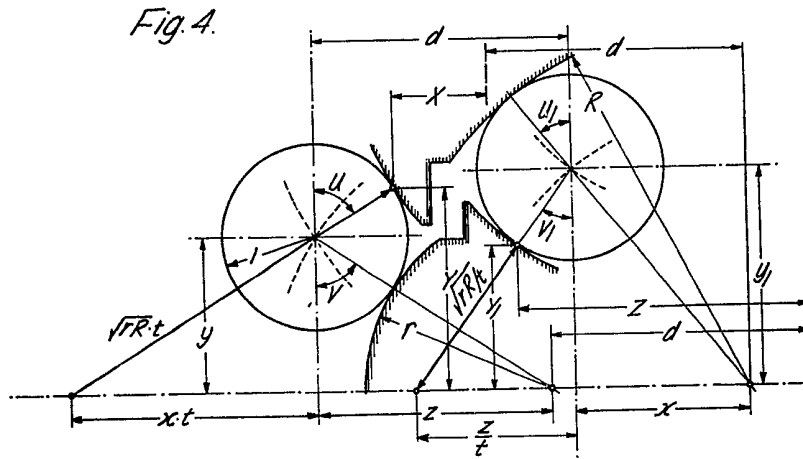
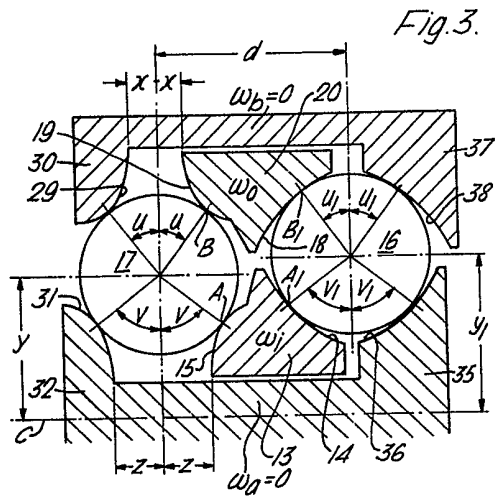

Fig. 5.

$r=2$   $R=4$   $C=3.08$

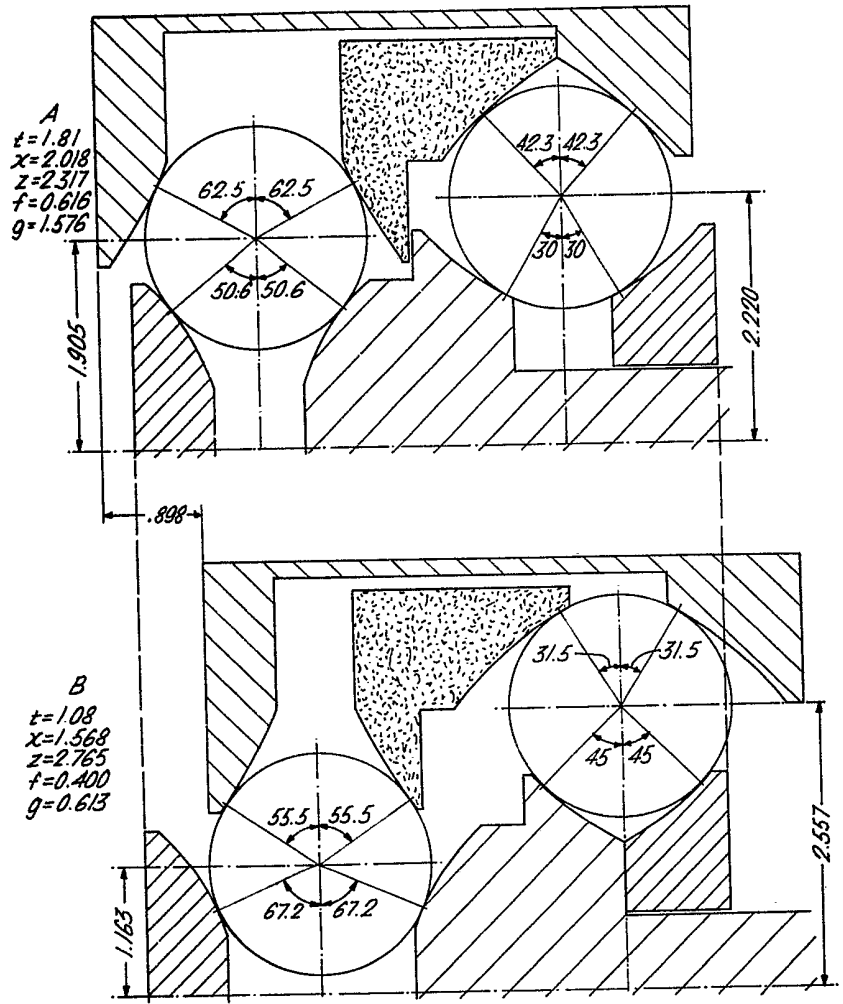
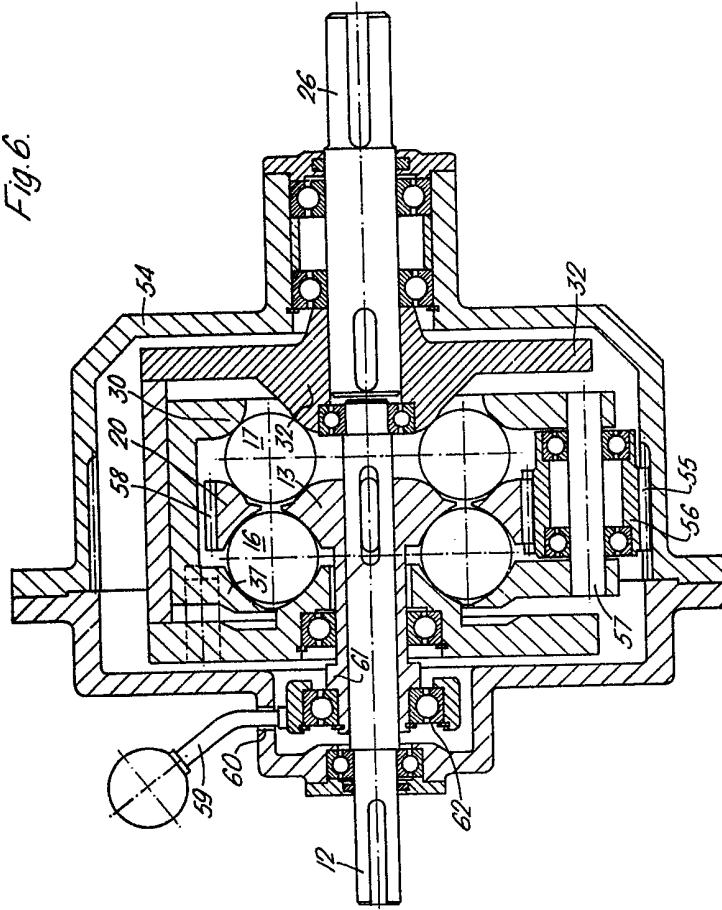



Fig. 6.



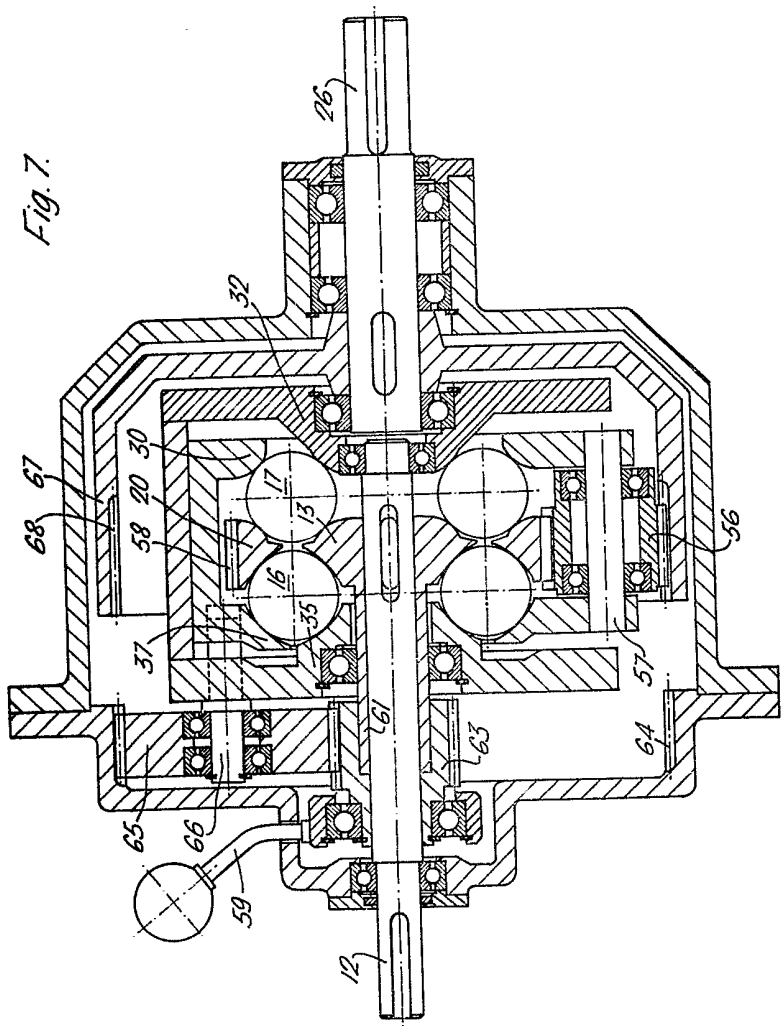
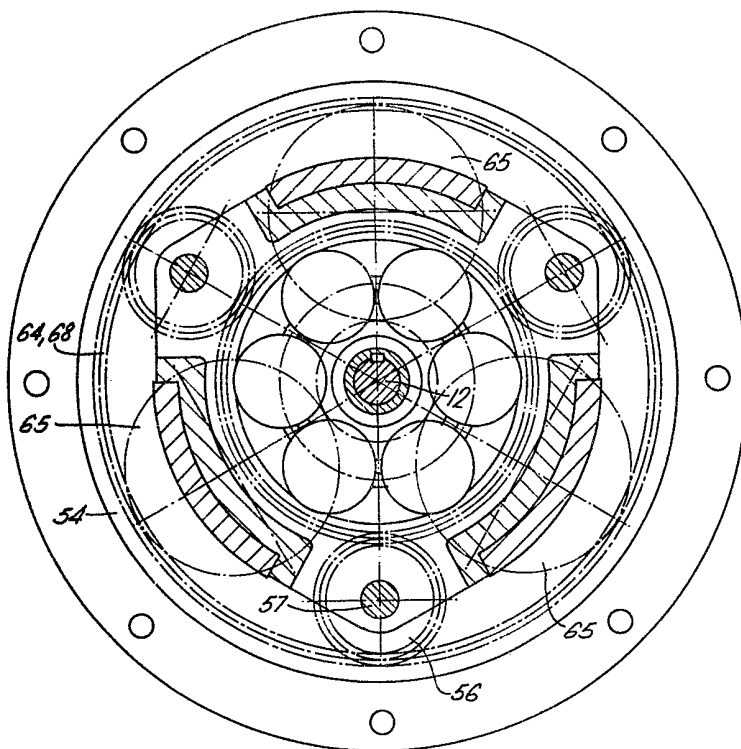
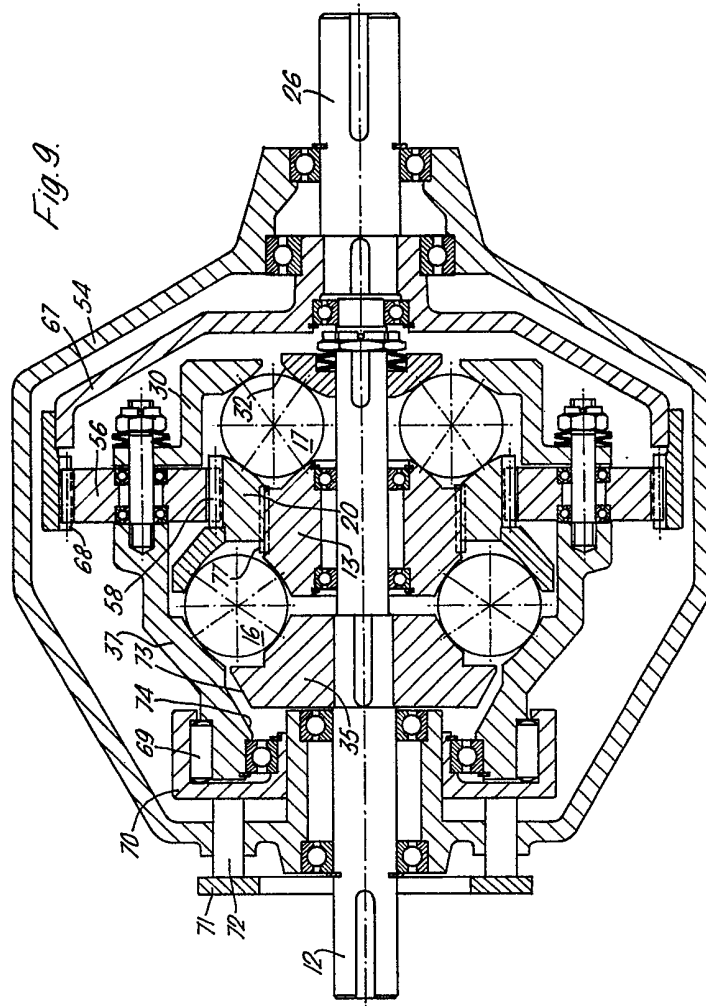

Fig. 8.





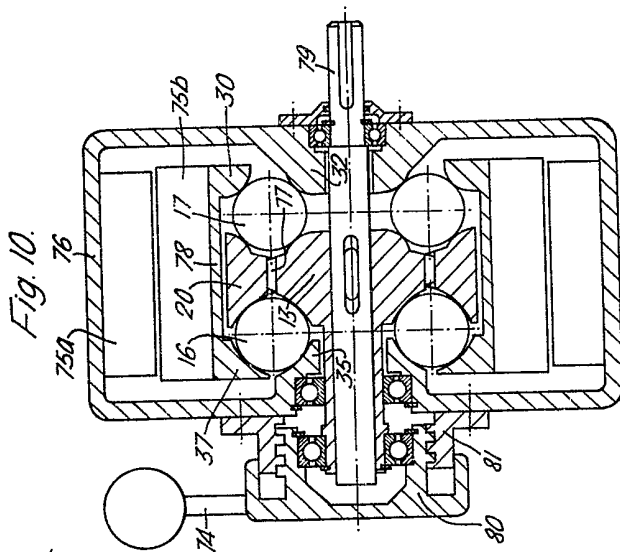
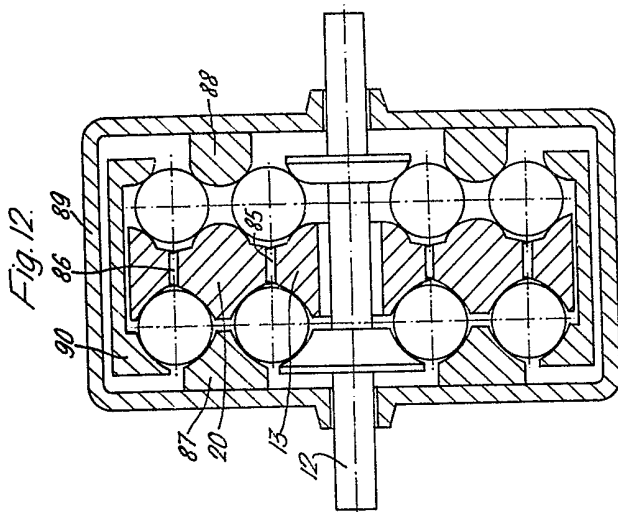

Fig. 11.

