



US0D1048635S

(12) **United States Design Patent**  
**Xiao**

(10) **Patent No.:** **US D1,048,635 S**

(45) **Date of Patent:** **\*\* Oct. 22, 2024**

(54) **DINING CAR**

(71) Applicant: **Shenzhen Yuanchenshi Technology Co., LTD, Shenzhen (CN)**

(72) Inventor: **Xiaolong Xiao, Shenzhen (CN)**

(73) Assignee: **Shenzhen Yuanchenshi Technology Co., LTD, Shenzhen (CN)**

(\*\*) Term: **15 Years**

(21) Appl. No.: **29/950,266**

(22) Filed: **Jul. 2, 2024**

(51) **LOC (14) Cl.** ..... **12-02**

(52) **U.S. Cl.**  
USPC ..... **D34/17; D34/12**

(58) **Field of Classification Search**  
USPC ..... D34/12, 17, 23; D21/534, 536, 425  
CPC .. B62B 3/02; B62B 3/10; B62B 3/007; B62B 1/12; B62B 1/22; B62B 5/0438; B62B 2205/12; B62B 2205/30; B62B 7/008  
See application file for complete search history.

(56) **References Cited**

**U.S. PATENT DOCUMENTS**

D388,473	S	*	12/1997	Pasin	.....	D12/129
D730,010	S	*	5/2015	Jin	.....	D34/12
9,085,311	B1	*	7/2015	Chen	.....	B62B 3/001
9,145,154	B1	*	9/2015	Horowitz	.....	B62B 5/0013
D748,739	S	*	2/2016	Horowitz	.....	D21/425
9,956,981	B1	*	5/2018	Fitzwater	.....	B62B 5/082
10,040,470	B1	*	8/2018	Horowitz	.....	B62B 3/102
11,465,664	B1	*	10/2022	Choi	.....	B62B 3/025
D979,171	S		2/2023	McBride		
11,590,994	B2	*	2/2023	DeBry	.....	B62B 3/002

D1,000,536	S	*	10/2023	Wu	.....	D34/12
D1,000,537	S	*	10/2023	Wu	.....	D34/12
D1,000,538	S	*	10/2023	Wu	.....	D34/12
2015/0151771	A1	*	6/2015	Jin	.....	B62B 5/0013 280/651
2018/0170418	A1	*	6/2018	Choi	.....	C08L 63/00
2020/0340267	A1	*	10/2020	Zemskov	.....	B62B 9/14
2021/0002919	A1	*	1/2021	Camillo	.....	B62B 5/0013

**OTHER PUBLICATIONS**

Wonderfold, announced Mar. 2021 [online], [site visited Aug. 19, 2024]. Avail from int, URL: [https://www.amazon.com/WONDERFOLD-Luxe-Stroller-Wagon-Seater/dp/B08S3TN1S9/ref=sr\\_1\\_3](https://www.amazon.com/WONDERFOLD-Luxe-Stroller-Wagon-Seater/dp/B08S3TN1S9/ref=sr_1_3) (Year: 2021).\*

\* cited by examiner

*Primary Examiner* — Cynthia Ramirez  
*Assistant Examiner* — Tamara L Hahn

(57) **CLAIM**

The ornamental design for a dining car, as shown and described.

**DESCRIPTION**

FIG. 1 is a front perspective view of a dining car, showing my new design;  
FIG. 2 is a rear perspective view thereof;  
FIG. 3 is a front view thereof;  
FIG. 4 is a rear view thereof;  
FIG. 5 is a left side view thereof;  
FIG. 6 is a right side view thereof;  
FIG. 7 is a top view thereof; and,  
FIG. 8 is a bottom view.  
The broken lines in the drawings illustrate the portions of the dining car, which form no part of the claimed design.

**1 Claim, 8 Drawing Sheets**

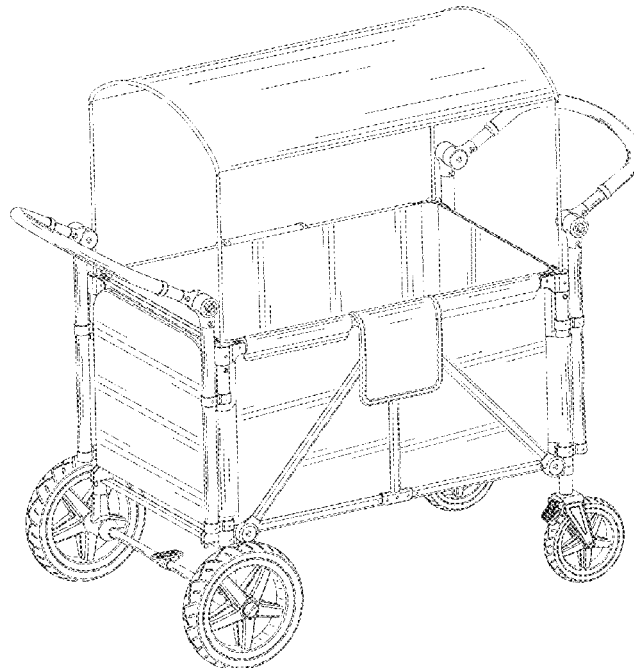

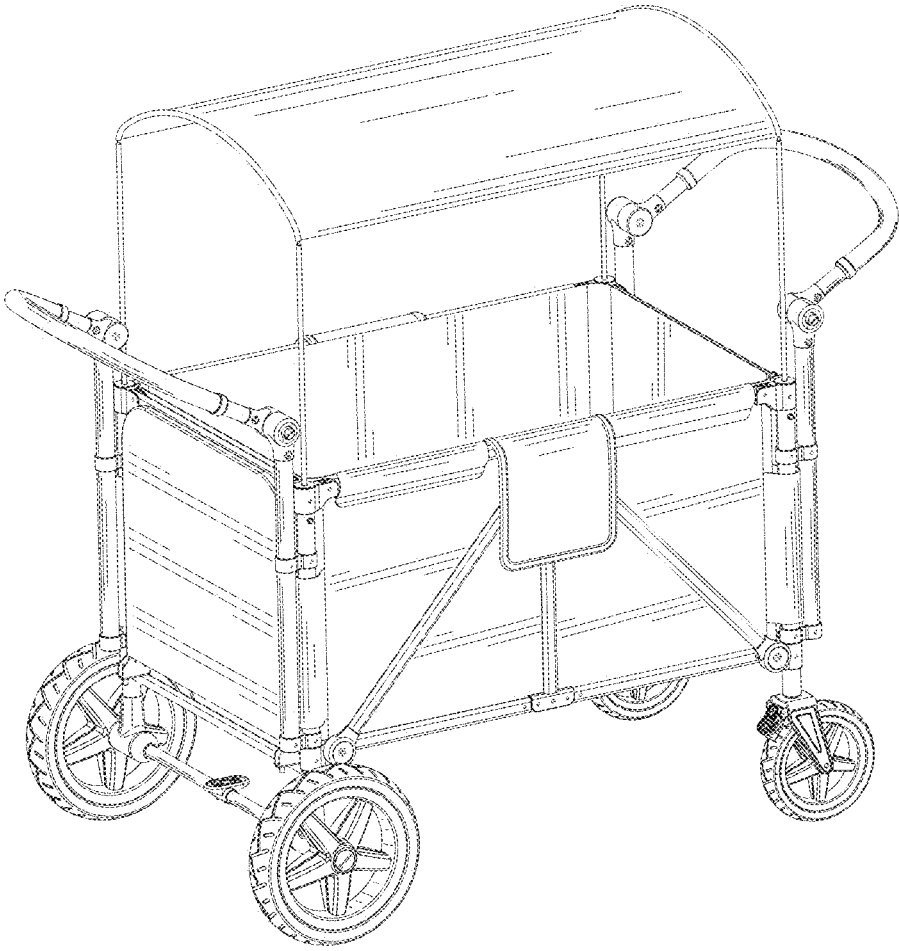
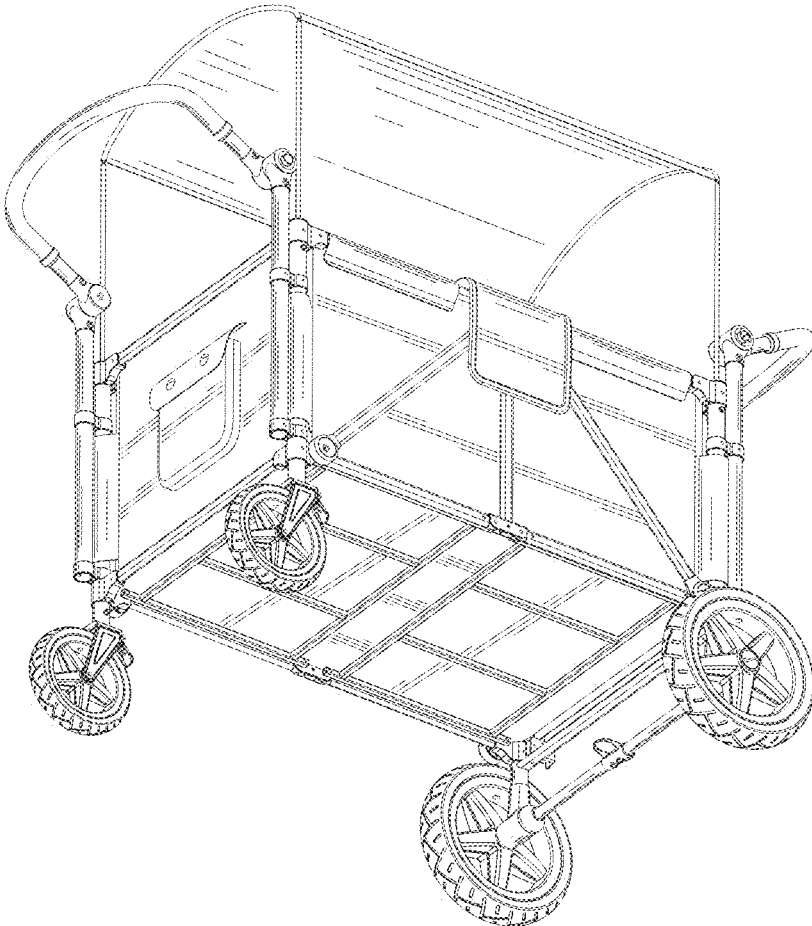

FIG. 1



**FIG. 2**

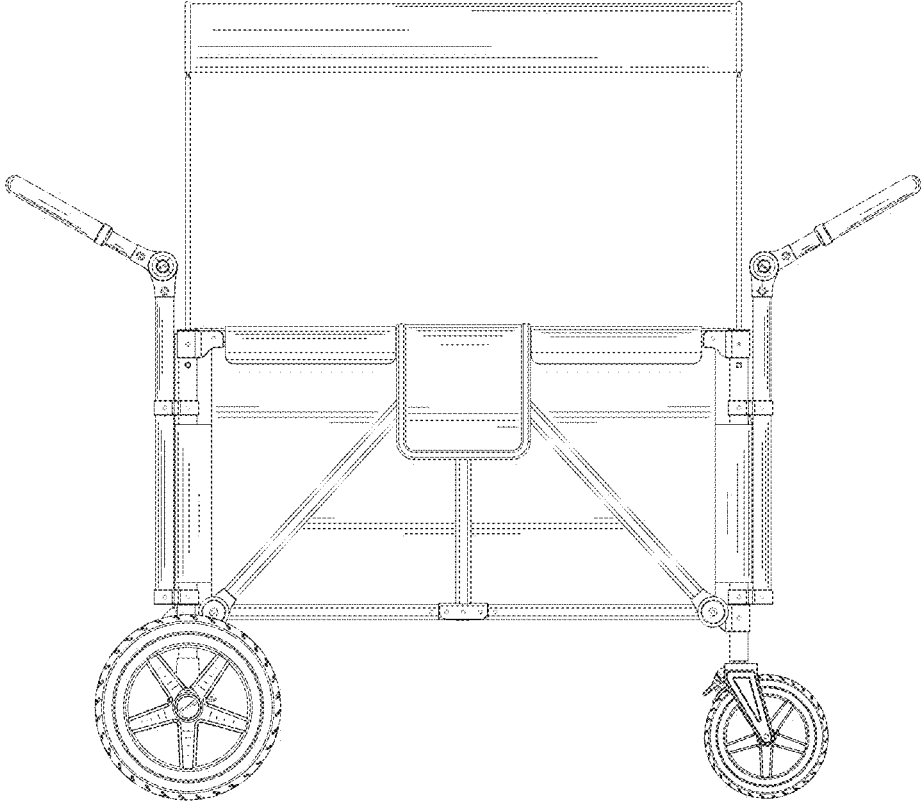

FIG. 3

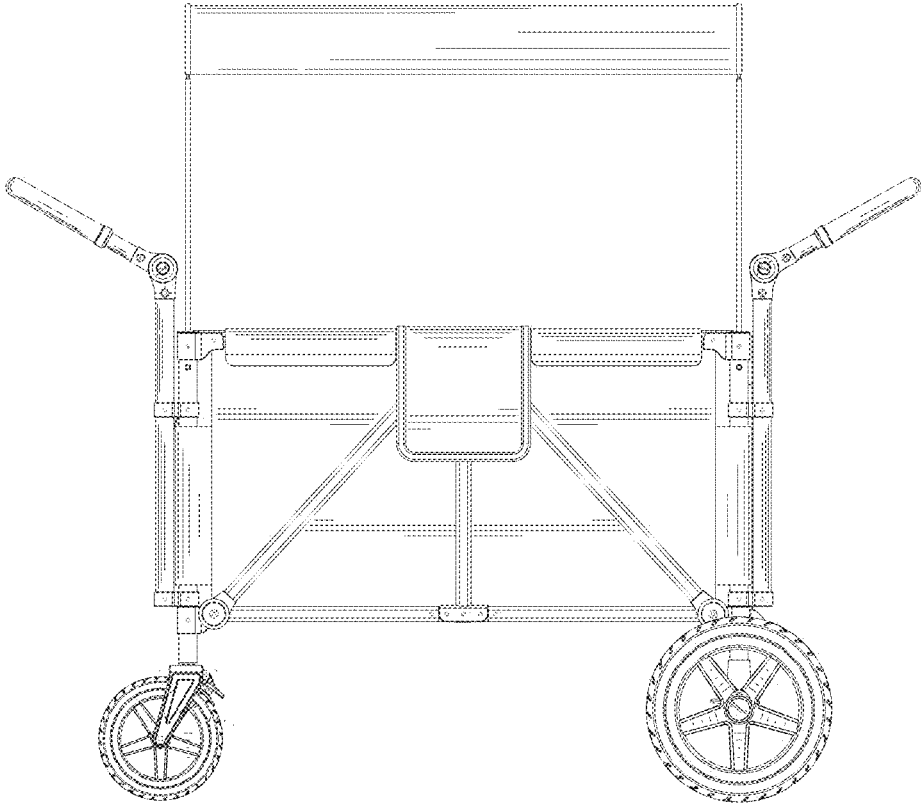

FIG. 4

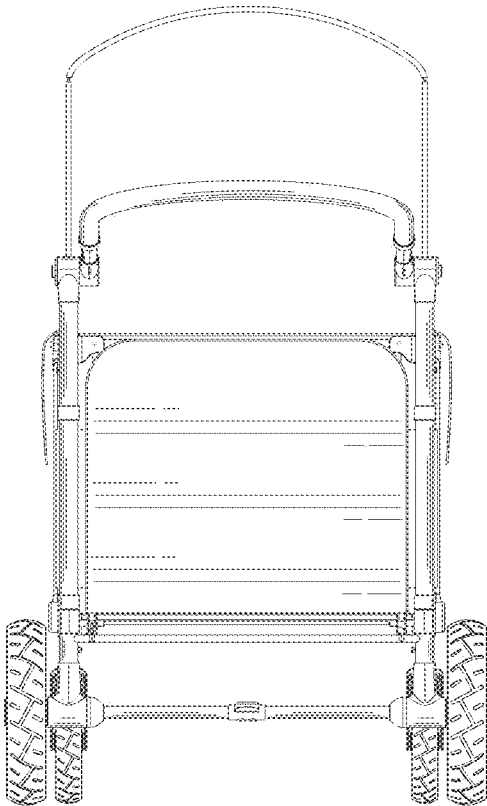
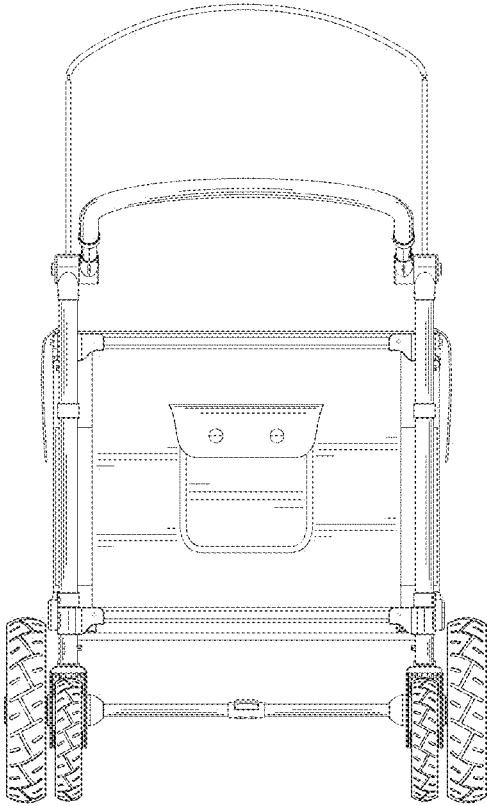

FIG. 5



*FIG. 6*

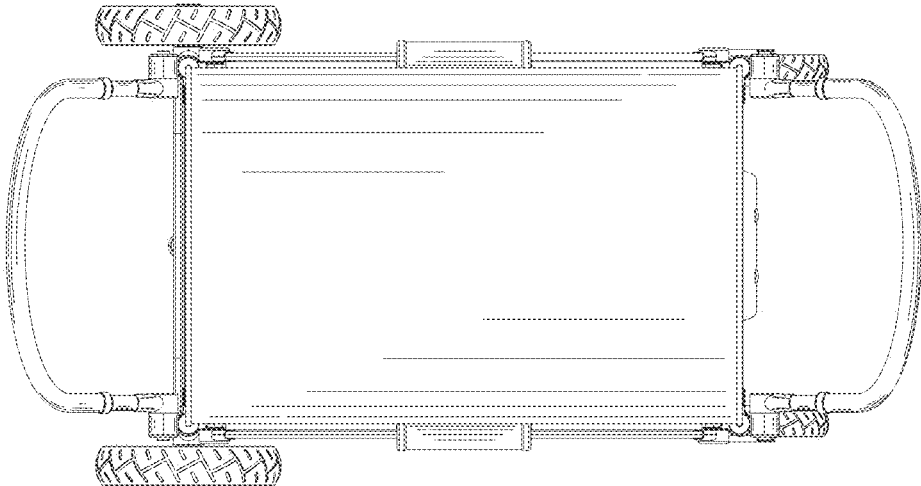

FIG. 7



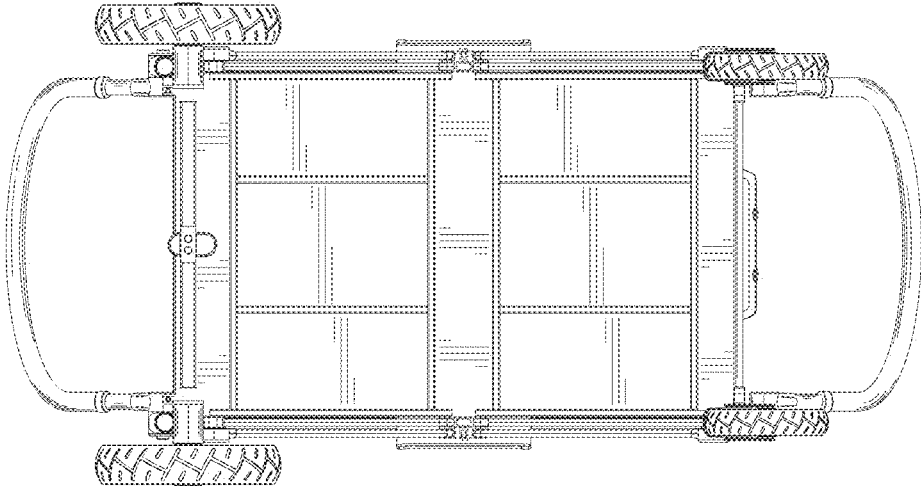

FIG. 8