

M. CAMPBELL.
SPINNING MACHINE.

APPLICATION FILED JUNE 24, 1901.

7 SHEETS—SHEET 1.

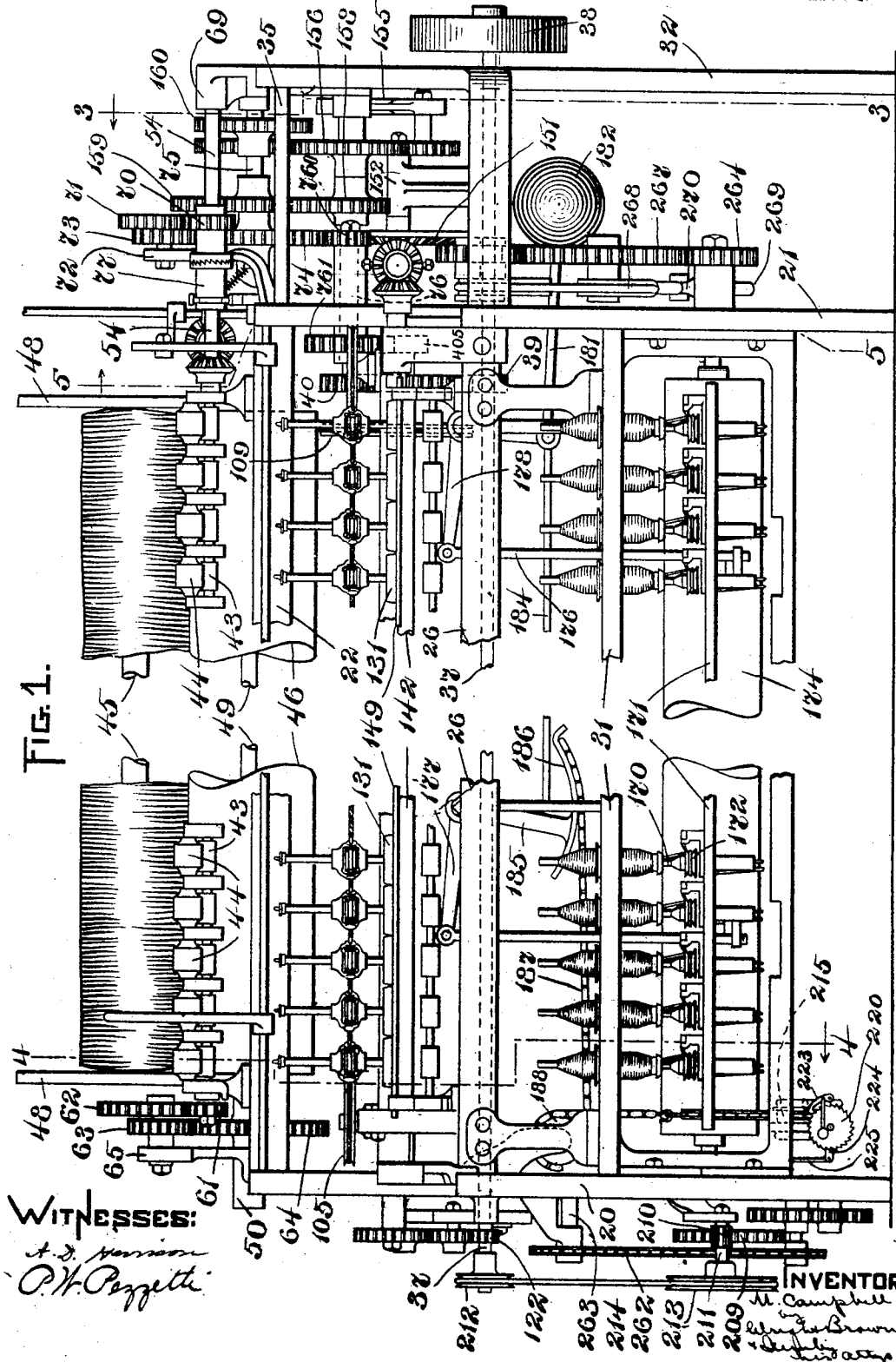

FIG. 1.

WITNESSES:
A. J. Harrison
O. H. Pezzetti

INVENTOR
M. Campbell
M. Campbell

M. CAMPBELL.
SPINNING MACHINE.
APPLICATION FILED JUNE 24, 1901.

7 SHEETS—SHEET 2.

FIG. 2.

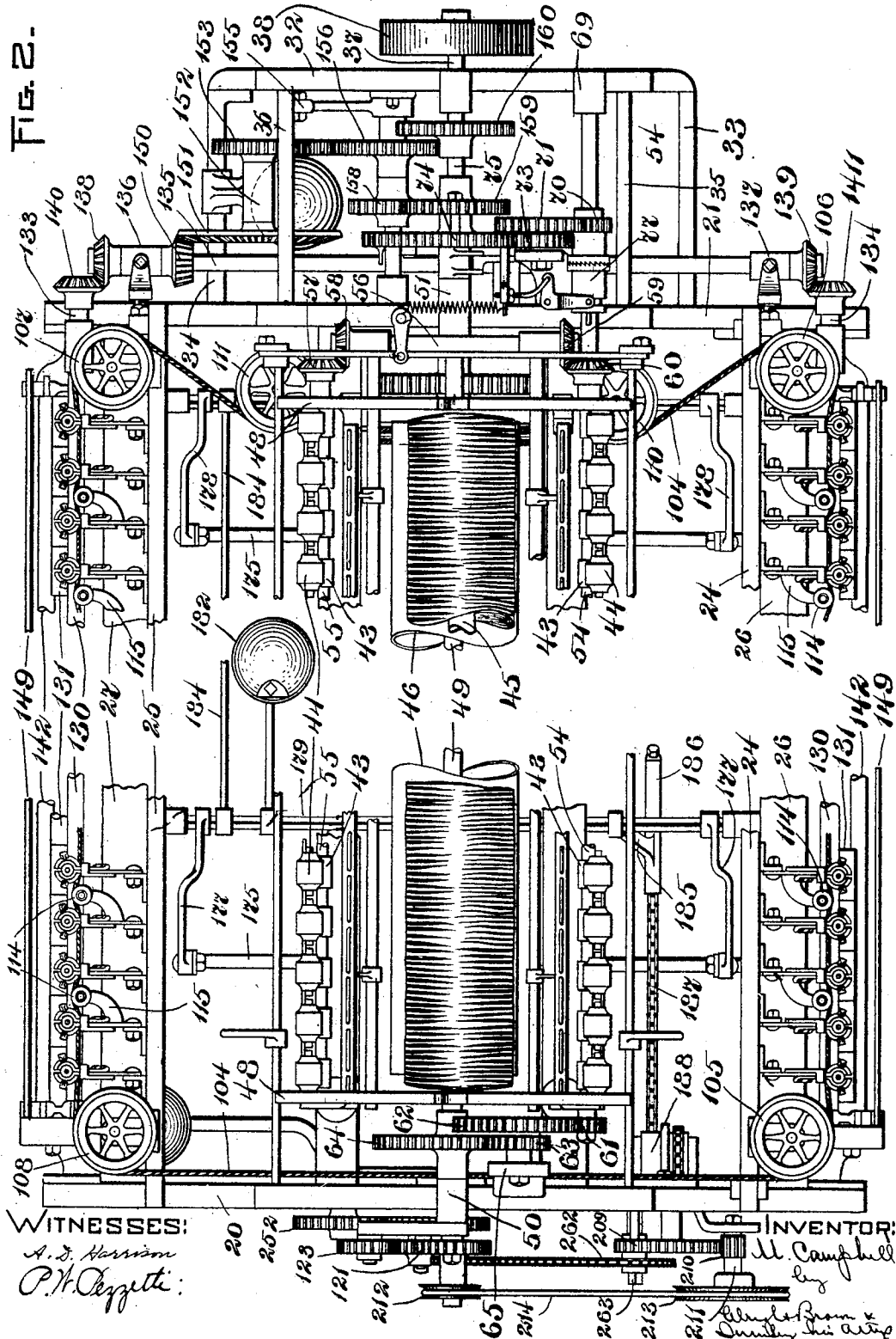

M. CAMPBELL.
SPINNING MACHINE.
APPLICATION FILED JUNE 24, 1901.

FIG. 3.

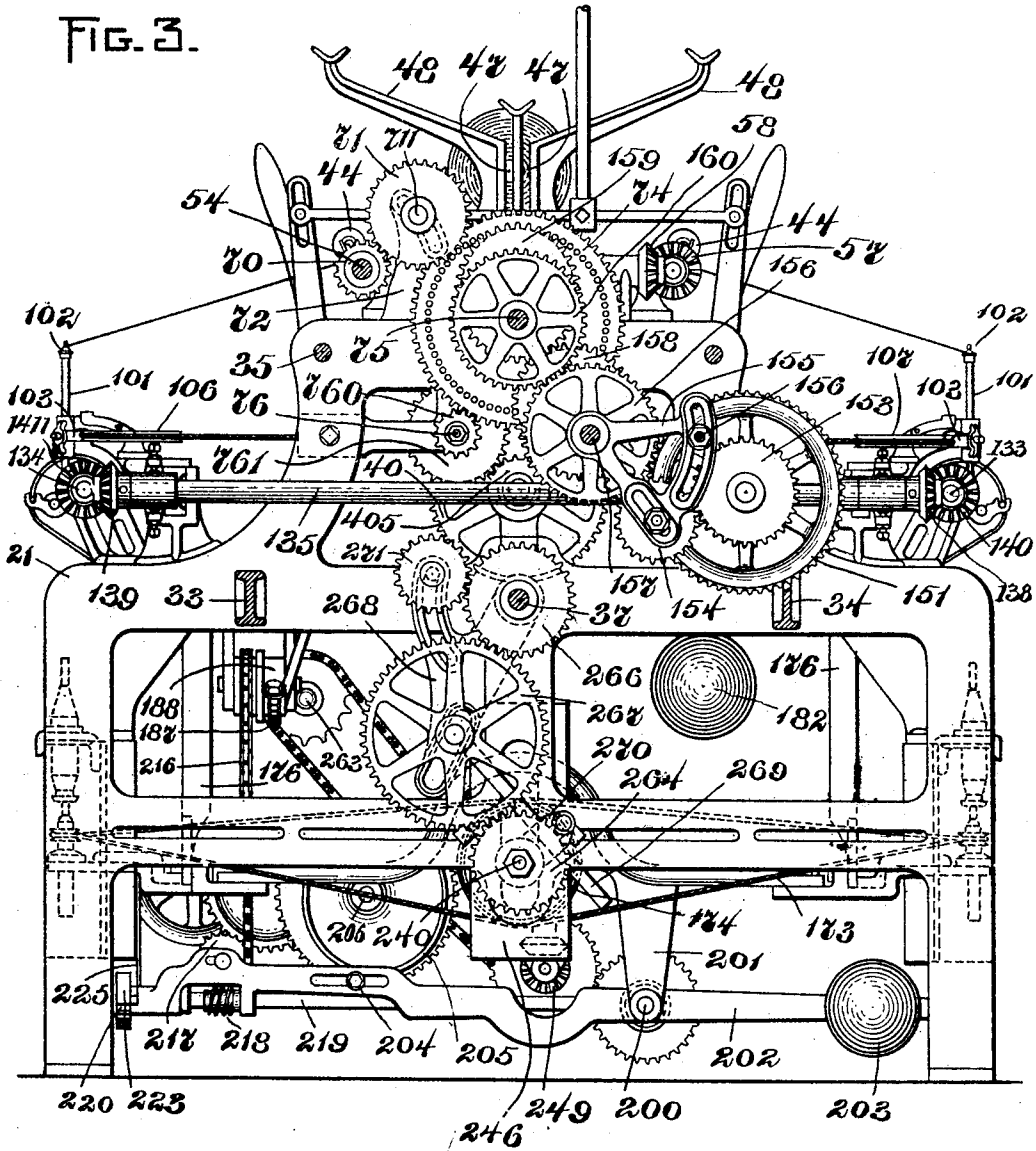

WITNESSES:

A. S. Hattin
P. H. Gazzelle

INVENTOR:

Malcolm Campbell.
by
Charles Brown - Dudley
his Atty

M. CAMPBELL.
SPINNING MACHINE.
APPLICATION FILED JUNE 24, 1901.

FIG. 4.

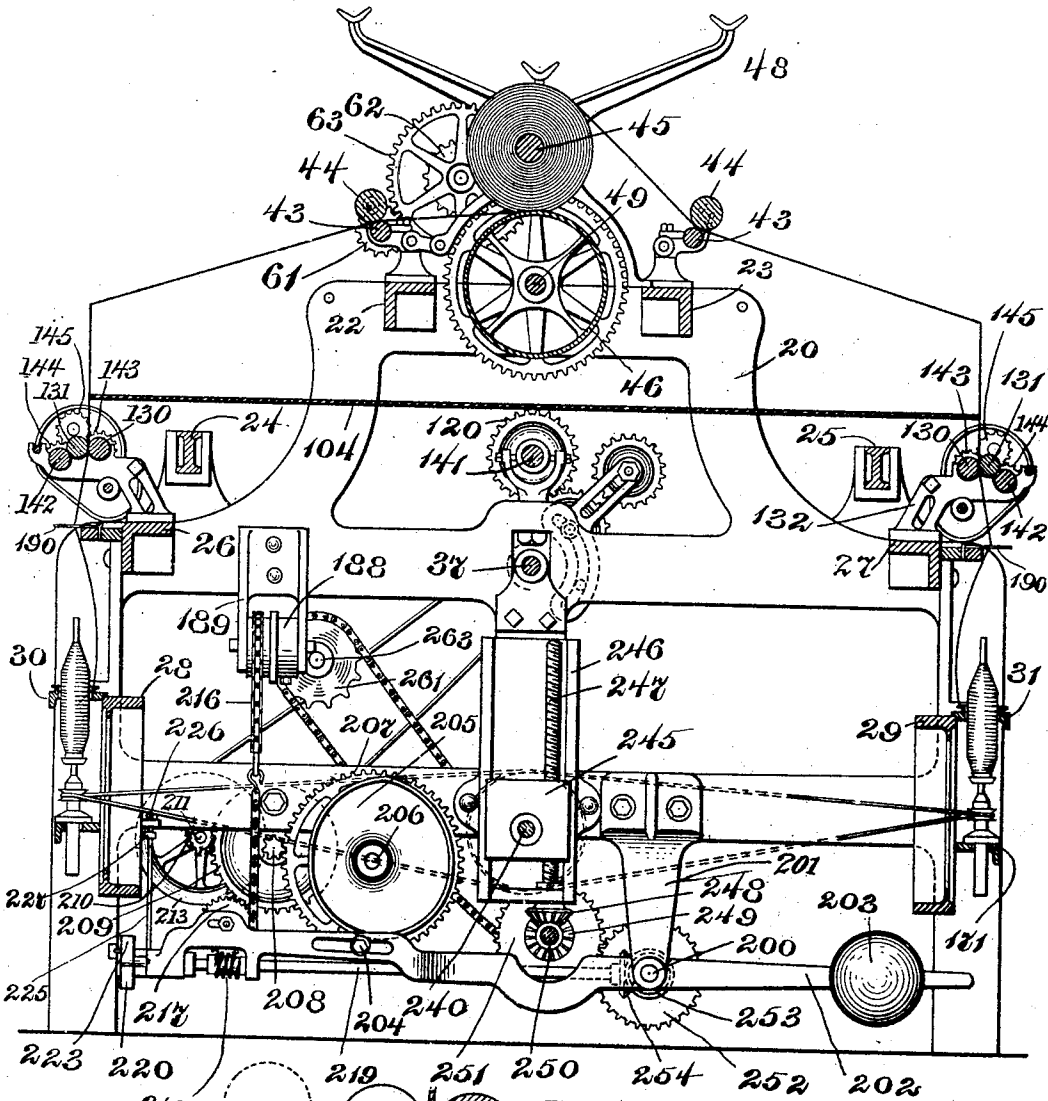
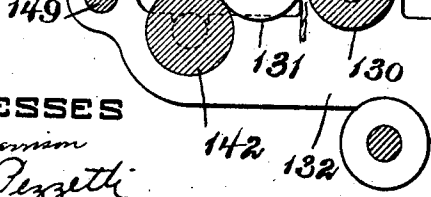

FIG. 10.



WITNESSES
A. S. Herman
P. H. Pezzetti

INVENTOR:
M. Campbell
by
Edw. Brown &
Co.
Attorneys

M. CAMPBELL.
SPINNING MACHINE.
APPLICATION FILED JUNE 24, 1901.

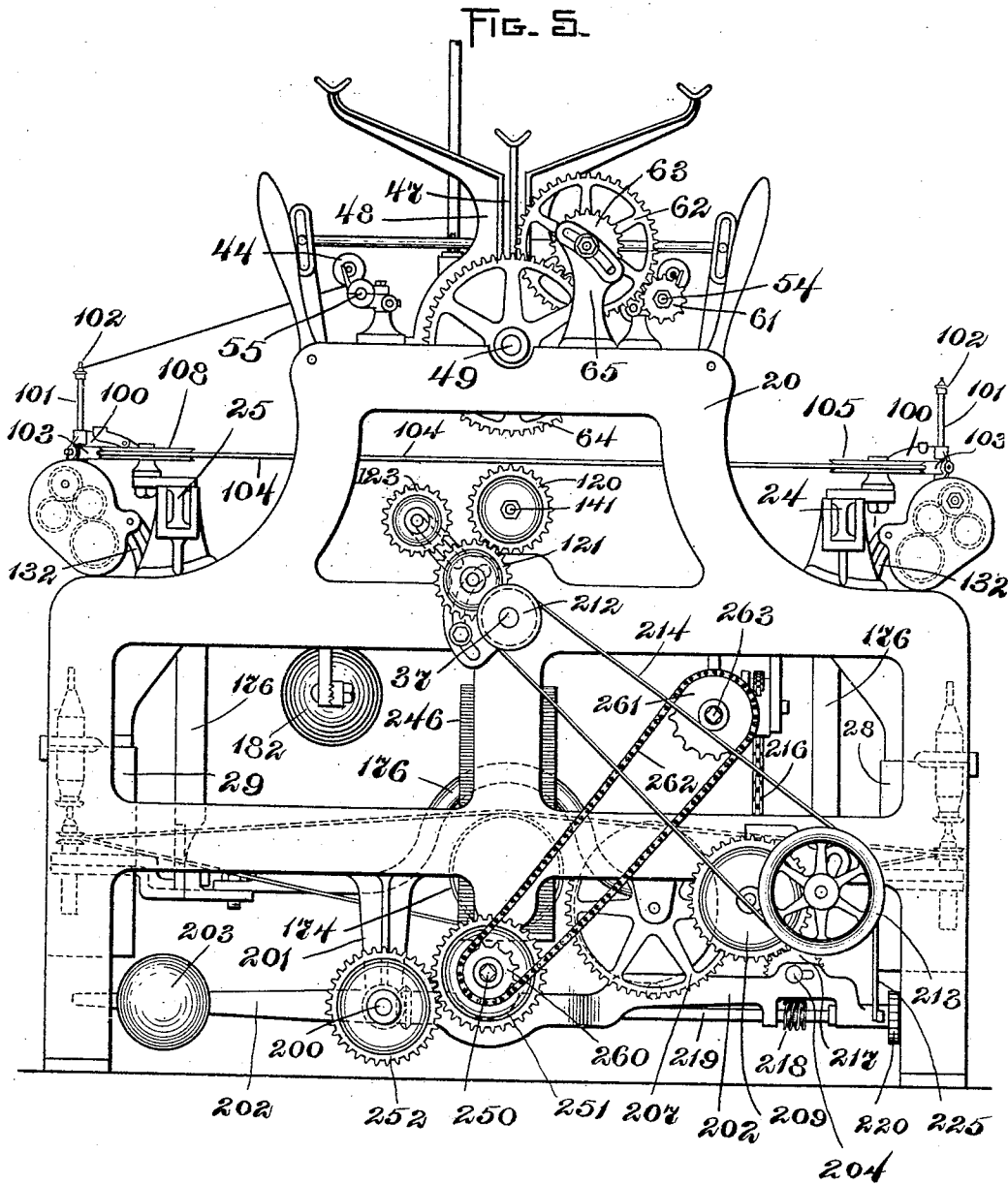

WITNESSES:
A. S. Harrison
P. W. Pezzetti

INVENTOR:
Malcolm Campbell
 by *Wm. Brown & Quincy*
his attys

M. CAMPBELL.
SPINNING MACHINE.
APPLICATION FILED JUNE 24, 1901.

FIG. 6.

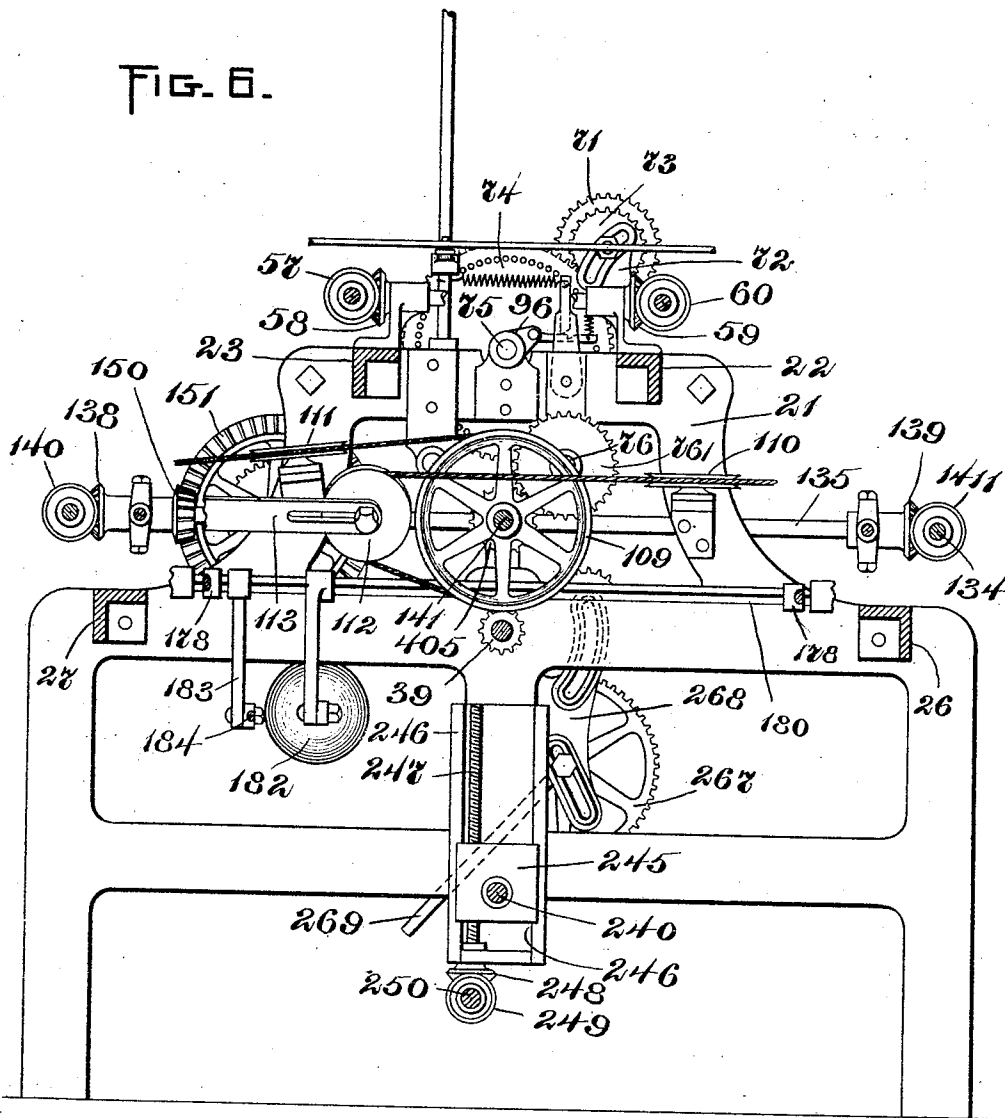

WITNESSES:

A. D. Harrison
P. H. Pizzetti

INVENTOR:

M. Campbell
By *Alfred Brown & Son*
his attys

M. CAMPBELL.
SPINNING MACHINE.
APPLICATION FILED JUNE 24, 1901.

7 SHEETS—SHEET 7.

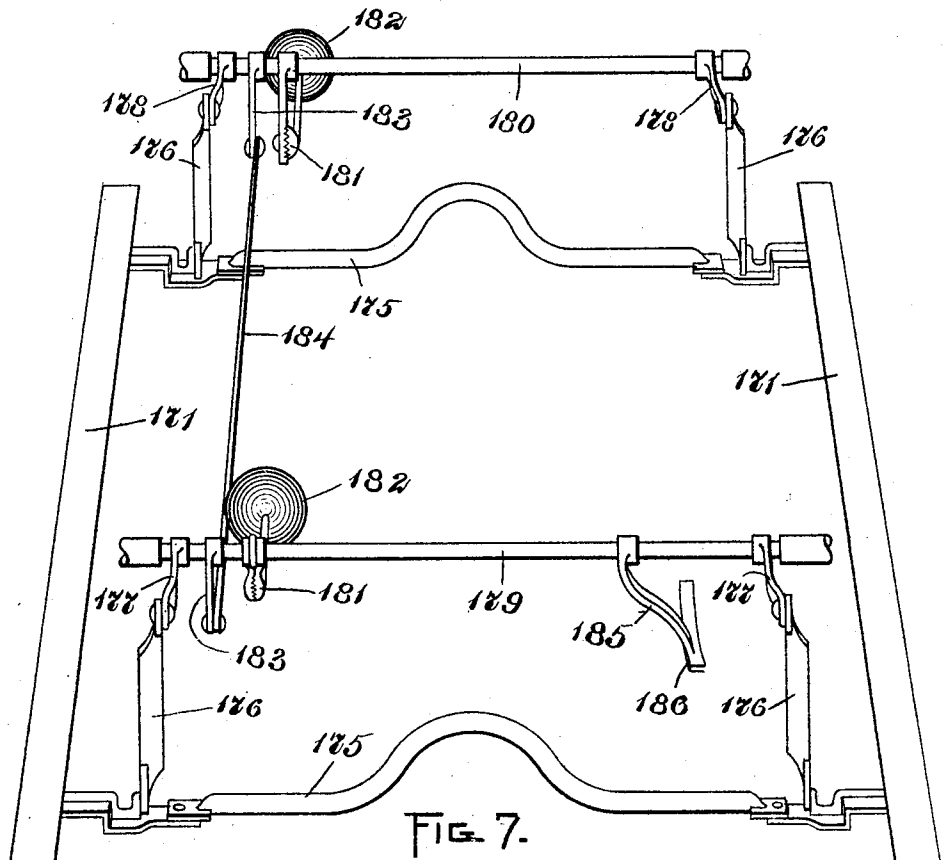
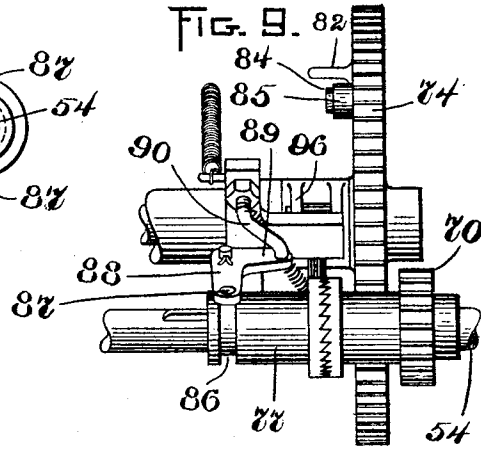
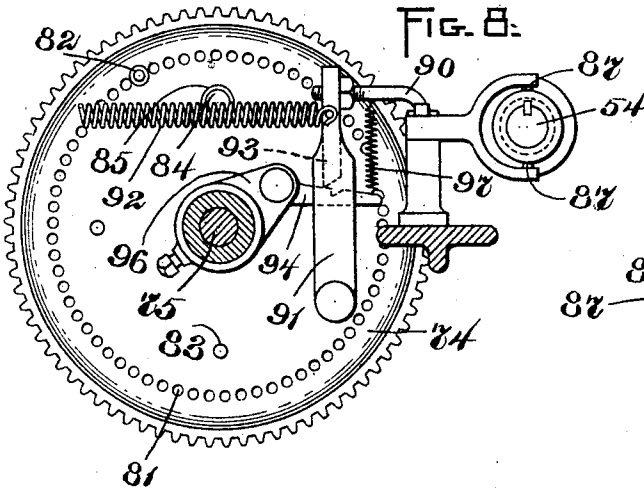

WITNESSES:
A. D. Harrison
O. W. Pezzetta.

INVENTOR:
Malcolm Campbell
by
Wm. H. Brown & Son
Ins. Atty.

UNITED STATES PATENT OFFICE.

MALCOLM CAMPBELL, OF BOSTON, MASSACHUSETTS.

SPINNING-MACHINE.

No. 803,551.

Specification of Letters Patent.

Patented Nov. 7, 1905.

Application filed June 24, 1901. Serial No. 65,818.

To all whom it may concern:

Be it known that I, MALCOLM CAMPBELL, of Boston, in the county of Suffolk and State of Massachusetts, have invented certain new and useful Improvements in Spinning-Machines, of which the following is a specification.

This invention has relation to spinning-machines, having for its object to provide certain improvements therein whereby the efficiency of such machines may be enhanced and the quality and production of the yarn increased.

Referring to the accompanying drawings, which illustrate one embodiment of the invention, Figure 1 represents a front elevation with the middle portion broken away of a machine embodying my invention. Fig. 2 represents a plan view of the same. Fig. 3 represents a gearing in end elevation, being a section on the line 3 3 of Fig. 1 looking in the direction of the arrow. Fig. 4 represents a section on line 4 4 of Fig. 1. Fig. 5 represents a section on line 5 5 of Fig. 1 looking in the direction of the arrow. Fig. 6 represents an end elevation of the machine looking from the left in Fig. 1. Fig. 7 represents in perspective view the spindle-rails and the means for supporting and moving them. Figs. 8 and 9 represent in detail the automatic clutch-operating mechanism. Fig. 10 shows in detail the lower drawing-roll.

The machine is provided with delivery-rolls to which the roving is delivered from a beam resting upon a drum. Each roving passes from the delivery-rolls, which are rotated intermittingly, to twister-heads, by means of which it is elongated or drawn and twisted, passing thence to the drawing-rolls, from which it is delivered to the ring-spinning mechanism. The twister-heads and the bobbin-spindles are rotated at a uniform constant speed, whereas the drawing-rolls may be driven either at a constant speed or else with an intermittently accelerated and retarded speed, the acceleration in speed of the drawing-rolls taking place coincidentally with the period of rotation of the delivery-rolls, so that the drawing action of the drawing-rolls is more rapid during the let-off of the roving than at other times. In these respects the machine is somewhat similar in function to the machine illustrated and described in the patent to Edmund K. Baker, No. 519,491, dated May 8, 1894.

General construction.—The machine is formed with the usual framework, including the end standards 20 21, connected by the rails

22 23 for the delivery-rolls, the rails 24 25 for the twister-heads, the rails 26 27 for supporting the lower drawing-rolls, and the frames 28 29 upon which the ring-rails 30 31 are mounted. Projecting from one end of the machine is a frame comprising the outer standard 32, the side bars 33 34, and tie-rods 35 36. (See Figs. 1 and 3.) In the standards 20, 21, and 32 is journaled the main driving-shaft 37, carrying the belt-pulley 38. The said shaft has secured thereto a pinion 39, intermeshing with and driving a large gear 40, loose on a shaft 141, from which power is carried to the lower drawing-rolls by means which I shall subsequently describe.

Yarn-delivering mechanism.—The trunnions of the roving-beam 45 project into slots 47 in uprights 48, supported upon rails 22 23, and the said beam rests loosely upon the drum 46, which is secured upon a shaft 49, projected beyond the side standards 20 21 and journaled in bearings 50 51 on the tops of said standards. The drum rotates in unison with the delivering-rolls 43 44, being geared thereto, as will be described. The delivery-rolls 43 44 are on two shafts 54 55, (see Fig. 2,) which are geared together through the cross-shaft 56 and the bevel-gears 57 58 59 60. The shaft 54, to which the power is supplied from the main driving-shaft, is equipped at one end with a pinion 61, intermeshing with a large gear 62, with which is compounded a smaller gear 63, in operative engagement with a large gear 64 on the drum-shaft. The shaft for the gears 62 63 is adjustably secured in a bracket 65, rising from the top of standard 20, and provision is made for the interchange of larger or smaller gears to effect different speeds of the drum. The shaft 54 is longitudinally extended to have its ends in a bearing 69 in the standard 32, so that rotative movement may be imparted to it from the main driving-shaft 37. Mounted loosely upon said shaft 54 is a pinion 70, which may be clutched thereto by mechanism to be described. This pinion intermeshes with and is driven by change-gear 71 on a stud-shaft 711, adjustably mounted in a bracket 72 on the top of standard 21. Affixed to the gear 71 is a smaller gear 73, intermeshing with and driven by a large gear 74, fast on a shaft 75, journaled in standards 21 32. This shaft 75 is in parallelism with and directly above the shaft 37, and it is driven from said shaft 37 by the following train of gearing: The gear 39 on the shaft 37 drives the gear 40, which is loose on the

shaft 41. A gear 405 is fast with the gear 39 and drives a gear 761, fast on the shaft 76. The shaft 76 has upon it a pinion 760, intermeshing with and driving the said gear 74, so that the power is transmitted directly from the main power-shaft to the gear 70 and thence to the delivery-rolls, as will be set forth. The top rolls 44 are loosely mounted, as ordinarily, and may be removed by hand, bearing frictionally against the lower rolls 43, so as to grip the yarn thereagainst.

Mechanism is provided to stop and start the rolls 43, so that the let-off of the roving will be intermittent. To accomplish this, I utilize the clutch 77 on the shaft 54. The said clutch is splined on the shaft and is provided with teeth adapted to coact with similar teeth formed on the hub of the gear 70. The clutch is automatically operated once for each rotation of gear 74. This gear I term the "pin-wheel," as it is provided with a circular row of apertures 81 for the reception of a pin 82. (See Figs. 8 and 9.) This pin 82 may be inserted in any one of the apertures 81 and is designed to effect the unclutching of the gear 70 and the shaft 54. The wheel or gear 74 is also provided with a plurality of apertures 83, arranged inside of the row of apertures 81. As shown, there are four of said apertures 83; but they may be increased or decreased in number, as desired. Said apertures are provided for the reception of a pin 84, carrying a roll 85, by which the engagement of the clutch with the gear 70 is effected. The clutch is provided with a groove 86, with which pins 87 on a bell-crank 88 are engaged. Said bell-crank is bifurcated, as shown in Fig. 8, and its other arm 89 is connected by a rod 90 with a lever 91, fulcrumed on a bracket 40 extending out from the end standard, (not shown,) as indicated in Fig. 6. A helical spring 92 tends to draw the lever 91 into position to effect the disengagement of the clutch from the gear. Said lever is provided with a cam projection 93, adapted to be engaged by the roll 84, to move said lever against stress of the spring 92 and thrust the clutch into operative position. To hold it there, I provide a latch 94, fulcrumed on a collar 96, secured to the bearing of the shaft 75, said latch having a notch to receive the end of the cam projection 93. A spring 97 holds the latch upwardly in position to engage the cam projection. The end of the latch is in position to be engaged by the pin 82 as the wheel 74 rotates. In the operation of the device the wheel 74 rotates constantly, and each time the roll 84 engages the lever 91 it effects the clutching of the gear 70 and the shaft 54, so as to rotate the delivering-rolls and let off the roving. As soon as the pin 82, however, engages the latch 94 the lever 91 is released, and the spring 92, drawing it backward, thrusts the clutch into inoperative position. Inasmuch as the delivering-rolls and the drum are geared together, their

movement is in unison, and when one stops the other stops also.

Each twister-head is mounted in a separate standard, (indicated at 100,) and it consists of a tube 101, arranged substantially vertically or at an angle to the line connecting the delivering-rolls with the drawing-rolls, so that the yarn takes the path shown in Fig. 4. The upper end of each tube 101 is formed with a projection 102 to engage and release the yarn at each rotation thereof. The lower end of the spindle is formed with a suitable gripper to engage the roving and twist it. Each spindle or tube is provided with a whirl 103, and all of the whirls are engaged by single continuous bands 104, which may be a cord, tape, rope, or belt. Preferably I employ a cord, which passes around idlers 105 106, arranged on one side of the frame, and idlers 107 108, arranged at the other side of the frame. The cord, as shown in Figs. 2 and 6, is driven from a driving-wheel 109 on shaft 141, being passed around inclined idlers 110 111, arranged between the idlers 106 107. A take-up roll 112 is interposed between the idler 110 and the driving-wheel 109, and it is adjustably journaled on a bar 113, bolted to the back of one of the twister-head rails. In order to cause the engagement of the band 104 with the whirls and the twisters, I provide a plurality of idlers 114, mounted in brackets 115, secured on the top of the twister-head rails 24 25, said idlers being disposed between each pair of whirls, so as to effect a proper engagement of a cord or driving-band 104 therewith. The wheel 109 is, as stated, mounted upon shaft 141, which extends through the machine from end to end and has upon its outer end, as shown in Figs. 1 and 5, a gear 120, intermeshing with and driven by a change-gear 121, in turn rotated by a pinion 122 on the main power-shaft 37. In order to vary the direction of rotation of the shaft 141, I employ an extra gear 123, which may be brought into engagement with the gears 120 and 121, in which event the last-named gear is adjusted in the slot in the bracket to which its shaft is secured. From this description it will be seen that the cord or pin-driving shaft receives its power directly from the main driving-shaft 37, so that the twister-heads rotate at a constant uniform speed.

Drawing-rolls and actuating mechanism therefor.—The drawing-rolls have a differential or constant movement at will, mechanism being provided for imparting to such rolls either an accelerated rotation or a uniform rotation, as desired. The said drawing-rolls are in pairs and are indicated at 130 131. The said drawing-rolls 130 are journaled in bearings 132, supported upon the rails 26 and 27, and they are formed on long shafts which extend from end to end of the machine, said shafts being indicated at 133 134 and arranged on the two sides of the machine. The said shafts

are connected together by a cross-shaft 135, journaled in bearings 136 137 and having on its ends bevel-gears 138 139, intermeshing with bevel-gears 140 141 on the shaft 133 134, respectively. Of each pair of drawing-rolls one is freely movable relatively to the other. It consists of a plurality of loose sections, one for each roving, as shown in Fig. 2, and it rests upon the roll 130 and upon a roll 142, which is journaled in bearings in the bracket 132 and is geared to its corresponding or adjacent roll. At the ends of the shafts opposite the ends upon which the bevel-gears are mounted the rolls 130 142 are equipped with gears 143 144 and with a common intermeshing idler 145, by means of which they are caused to rotate in the same direction. The rolls 130 and 142 are placed so closely together that the sections of the rolls 131 lie between them and are supported thereby, as shown in Figs. 4 and 10, so as to grip the roving against the roll 130. Inasmuch as the two roll-shafts rotate in the same direction, the roll-sections 131 will be caused to rotate in unison with them, so as to effect a firm grip on the roving and draw it as it leaves the twister-head. In order to permit "piecing up," each roll-section of the rolls 131 may be displaced and laid temporarily in the space between the roll 142 and the rod 149, placed in front of it and having its ends supported in brackets 132.

The means for imparting the accelerated motion to the lower drawing-rolls is best shown in Figs. 1, 3, and 6. The shaft 135 is provided with a bevel 150, with which is engaged a large driving bevel-gear 151, having its shaft journaled in the bearing 152. (See Figs. 1 and 2.) It receives its power from a gear 153, intermeshing with an idler-gear 154, having its shaft secured to an adjustable bearing 155, adapted to be adjusted in position and secured after adjustment by a screw 156, passed into the standard 32. The idler-gear 154 is driven by a gear 156 on shaft 157, having its ends journaled in standards 21 and 22. Fast upon said shaft is an elliptical gear 158, adapted to intermesh with and be driven by a complementary elliptical gear 159, splined on shaft 75. The shaft 75 carries, however, a plain gear 160, which may be intermeshed with the gear 156, in which event the elliptical gear 159 will be slid out of engagement with the elliptical gear 158. By means of the gears 156 160 or the gears 158 159 the shaft 135, and consequently the lower drawing-roll, may be driven at either a uniform constant speed or else at an accelerated speed, according to which gear, 159 or 160, is in engagement with its corresponding gear 158 or 156. When the accelerated gears are engaged so as to drive the lower drawing-rolls, they are so arranged that the period of acceleration of the drawing-rolls is coincident with the let off of the roving by the delivering-rolls, as previously explained.

Spindle and spindle-driving mechanism.—The spindles, which are of the ordinary construction, are indicated at 170. They are stepped in the vertically-reciprocating spindle-rail 171 and are each provided with a whirl 172, so as to be rotated by a cord 173, passed around the cylinder or driving-drum 174, as ordinarily. The spindle-rails 171 are connected by the cross-bars 175, which are secured to the lower end of links 176. There are a plurality of the latter and they depend from crank-arms 177 178, projecting laterally outward from the rock-shafts 179 180, respectively. The latter are journaled in suitable bearings, and they are provided with the angular jointed arms 181 181, to which the weights 182 are attached to counterbalance the weight of the rails and the spindles. The shafts are connected together by the arms 183 183 and the connecting-rod 184, so that they are caused to oscillate in unison. The shaft 179 is provided with an arm 185, having at its end a segmental extension 186. The segmental extension is connected to a chain 187, the other end of which is secured to an idler-drum 188, journaled in a bracket 189, secured to the standard 20, and, by means which I shall subsequently describe, the drum 188 is rotated or oscillated to take up or let out the chain 187 and cause the raising and lowering of the spindle-rails 171. The spindles and the bobbins are adapted to reciprocate through apertures formed in the ring-rails 31, the latter being equipped with the usual rings upon which are placed travelers. The yarn passes from the lower drawing-rolls to the travelers and thence to the bobbins, there being suitable yarn-guides or pig-tails 190 190, as ordinarily, interposed between the rings and the drawing-rolls.

For rotating the drum 174 it is secured upon a shaft 240, having at one end a gear 264, to which power is transmitted from the main driving-shaft 37. (See Fig. 3.) The transmitting mechanism includes a gear 266, fast on the shaft 37, and an idler-gear 267, whose stud-shaft is adjustably secured in an arm 268, pivoted upon the shaft 37. The said arm is hinged to a rod 269, which is adjustably secured to a rocker 270, pivoted upon the drum-shaft 240. These parts permit a movement of the shaft 240 toward and from the shaft 37 without disengaging the gear 267 from either the gears 264 266, since said gear 267 is placed to one side of a line connecting the axes of said shafts. To reverse the rotation of the drum, I employ a change-gear 271, the stud-shaft of which is adjustably secured in a curved lateral extension of the arm 268.

Builder mechanism.—The builder mechanism, by means of which the spindle-rails are caused to reciprocate, includes contrivances by means of which the spindle-driving cylinder or drum is raised and lowered coinci-

dently with the movement of the spindle-rail to cause the even and uniform rotation of the spindles and bobbins and also to prevent an increased strain upon the spindle-driving bands or cords.

Referring to Figs. 3 and 4, it will be seen that fulcrumed on the shaft 200, journaled in the bracket 201, there is a lever 202, bearing on one end of the counterweight 203. It is provided with an adjustable pin 204, carrying a roll which is caused by the weight 203 to bear against the cam 205 on a shaft 206. This shaft is provided with a large gear 207, intermeshing with a small pinion 208 on an idler-shaft, there being on said shaft also a larger gear 209, intermeshing with a small pinion 210 on a shaft 211 at the left end of the machine. (See Figs. 1 and 4.) Power is imparted to said shaft 211 from the driving-shaft 37 by means of the belt-pulleys 212 213 and the belt or cord 214. By means of this reducing-gear the cam is caused to rotate relatively slowly (say fifty or sixty turns per minute) and to cause the oscillation of the lever 202 a similar number of times per minute. Journaled on the end of lever 202 is a drum 215, and between it and the drum 188 is a two-part chain 216, one end of which is secured to one drum and the other end of which is secured to the other drum. Consequently the drum 188 is caused to oscillate in accordance with the oscillations of lever 202 to cause the reciprocation of the spindle-rails 171, and to thereby effect what is known as a "cop-build." The drum 215 is, however, formed with a worm-wheel 217, intermeshing with a worm 218 on a shaft 219, journaled in the lever, as shown in Fig. 3. This worm prevents the worm-wheel and the drum from unwinding, but when rotated itself causes the rotation of the drum 215 in one direction or the other, according to the lead of the worm-threads. On the extreme end of the shaft 219, which projects beyond the end of the lever 202, there is a ratchet-wheel 220 rigidly secured thereto. A weighted pawl 223 is hung upon the end of a lever 224, fulcrumed upon the shaft 219, and is connected at its end to an upright rod 225. This rod is provided with two adjustable nuts 226 227, above and below a lug 228, projecting out from the frame 28, and through which the rod 225 passes. The movement of the rod relatively to the lug is limited by the nuts 226 227. Thus it will be seen that each time the lever 202 is oscillated the small lever 224 will be likewise oscillated to cause the ratchet 223 to impart a partial rotation to the ratchet 220. Consequently, although the two-part chain 216 is moved up and down, by the lever 202, it will be gradually taken up and let out, as the case may be, from the drum 218 to cause a gradual lowering or raising of the spindle-rails in addition to the reciprocations thereof. I utilize this mechanism for adjusting or partially moving the

spindle-driving drum 174. This drum, as stated, is mounted upon the shaft 240, whose ends are journaled in boxes 245, adapted to slide vertically in guides 246, secured to the standards 20 and 21. The said boxes 245 are moved simultaneously up and down, being internally threaded to receive upright screw-rods 247, which are journaled in the guides 246 and are provided at their lower ends with bevels 248, intermeshing with bevel-gears 249 on a shaft 250, journaled in the standards. On its end the shaft 250 is provided with a gear 251, intermeshing with and driven by a gear 252 (see Fig. 5) on the end of shaft 200, previously referred to. This shaft 200 has a bevel-gear 253 intermeshing with and driven by a bevel-gear 254 on the worm-shaft 219. Consequently when said shaft 219 is rotated to cause the gradual raising and lowering of the spindle-rails the shaft 250 is also rotated slowly to cause a gradual movement of the journal-bearings 235 for the spindle-driving drum or cylinder. In order to doff the filled bobbins, the spindle-rails are raised to a position directly under the ring-rail. To accomplish this, I provide mechanism for manually rotating the shaft 250, by which the worm-shaft 219 is also rotated, and which, it will be remembered, is geared to the worm-gear 219.

I can, if desired, square the end of the shaft 250 or make it with a wrench-retaining formation; but for convenience I equip it with a sprocket-wheel 260 and stretch between it and another sprocket 261 a chain 262. The sprocket 261 is on a stud-shaft 263, the latter being formed at its end to receive a wrench or other tool, by which it may be rotated. Consequently after throwing the pawl 223 to an inoperative position the shaft 263 can be rotated to move the spindle-rail to any desired position.

It will be understood that while I have seen fit to describe the construction of the machine in detail, yet I may greatly vary many of the parts without departing from the spirit and scope of the invention, and various mechanical equivalents may be substituted for the several mechanisms which for convenience I have selected.

So far as I am aware I am the first to have caused the spindle-driving drum to be raised and lowered by the builder mechanism irrespective of the particular means for accomplishing it. I believe this mechanism to be a very desirable feature in a spinning-machine, for it effects a uniform rotation of the spindles and prevents a variation in the yarn. I likewise regard the elliptical gearing for effecting a differential movement of the drawing-rolls as an advance in the art, for it permits the proper acceleration of the said rolls without permitting them to actually stop and provides for a direct drive from the power-shaft.

The machine possesses many other features in addition to those of which special mention

has been made which are desirable and beneficial; but they will be understood and appreciated by those skilled in the art to which this invention relates, and I will not refer to them more specifically than has already been done.

Having thus explained the nature of the invention and described a way of constructing and using the same, although without attempting to set forth all of the forms in which it may be made or all of the modes of its use, I declare what I claim is—

1. A spinning-machine having a ring, a rotary spindle, builder mechanism, spindle-driving mechanism, and means supported independently of said builder mechanism and controlled by the latter, whereby the position of said spindle-driving mechanism is automatically controlled.

2. A spinning-machine having a ring and a traveler, a rotary spindle, a reciprocating spindle-rail, means for reciprocating the same, a spindle-driving drum, and means independent of said former means for adjusting said drum simultaneously with said rail.

3. A spinning-machine comprising a plurality of spindles, a spindle-rail, builder mechanism for raising and lowering said rail, a spindle-driving drum, and means supported independently of said builder mechanism and controlled thereby, whereby the position of said spindle-driving drum is automatically controlled.

4. A spinning-machine comprising a ring and traveler, a spindle, a spindle-rail, builder mechanism for raising and lowering said rail, a spindle-driving drum, and means independent of and actuated by said builder mechanism for adjusting said drum.

5. A spinning-machine having a reciprocating spindle-rail, means for raising and lowering the same, a spindle-driving drum, bearings therefor supported independent of said rail-reciprocating means, and means for raising and lowering said bearings as said spindle-rail is raised or lowered.

6. A spinning-machine having a reciprocating spindle-rail, a spindle-driving drum, bearings for said drum, and automatically-actuated screw mechanism for raising or lowering said bearings, and said drum, as the spindle-rail is raised or lowered.

7. A spinning-machine having a reciprocating spindle-rail, builder mechanism for actuating said rail, said mechanism including a lever, a spindle-driving drum, and mechanism independent of said former mechanism and operated by said lever for raising and lowering said drum.

8. A spinning-machine having a spindle-driving drum, a builder mechanism, including a worm-shaft, and means independent of

said builder mechanism and operated by said worm-shaft for automatically raising and lowering said drum.

9. A spinning-machine comprising a spindle-rail, means for moving said spindle-rail, a spindle-driving drum, means for adjusting the latter, a builder mechanism independent of said drum-adjusting means and connected with said rail-moving means, and means for simultaneously actuating said builder mechanism and said drum-adjusting means.

10. A spinning-machine comprising a spindle-rail, means for moving said spindle-rail, a spindle-driving drum, means for adjusting said drum, and a builder mechanism having provisions for simultaneously actuating said spindle-rail-moving means and said drum-adjusting means, said mechanism including a shaft geared both to the spindle-rail-moving means, and to the drum-adjusting means.

11. A spinning-machine comprising a spindle-rail, means for moving said spindle-rail, a spindle-driving drum, means for adjusting said drum, and a builder mechanism having provisions for simultaneously actuating said spindle-rail-moving means and said drum-adjusting means, said mechanism including a shaft geared both to the spindle-rail-moving means, and to the drum-adjusting means, a lever carrying said shaft and devices for effecting a rotation of said shaft.

12. A spinning-machine having delivery-rolls, a twister-head, drawing-rolls, and interchangeable elliptical and plain gearing whereby said drawing-rolls may be rotated either at a uniform speed by the plain gearing or at an intermittently accelerated and retarded speed by the elliptical gearing.

13. A spinning-machine having a twister-head, delivery-rolls, means including an automatic clutch for intermittently actuating said delivery-rolls, drawing-rolls, and mechanism including elliptical gears for actuating said drawing-rolls, said parts being arranged and related whereby said elliptical gears impart an accelerated movement to said drawing-rolls when the delivery-rolls are letting off the roving.

14. In combination, two separated rolls geared together to rotate in the same direction, a loose roll supported by said rolls, and adapted to coact with one of them, and a rod in such relation to the rolls, that said removable roll may be moved to inoperative position upon said rod and one of the first-said rolls.

In testimony whereof I have affixed my signature in presence of two witnesses.

MALCOLM CAMPBELL.

Witnesses:

C. C. STECHER,
E. BATCHELDER.