

June 26, 1923.

1,459,761

C. W. ANDREWS

PORTABLE HOUSE

Filed April 12, 1921

2 Sheets-Sheet 1

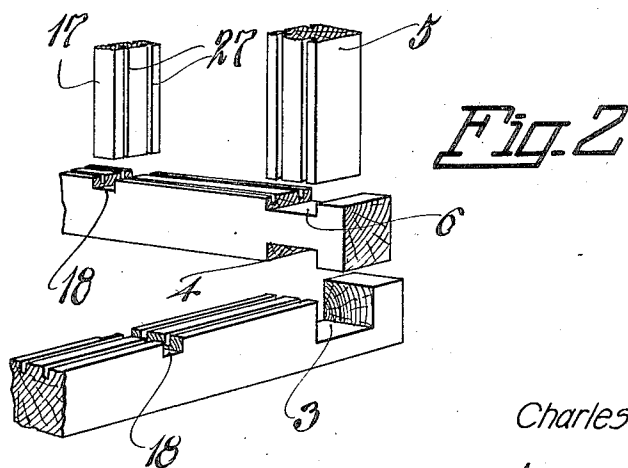
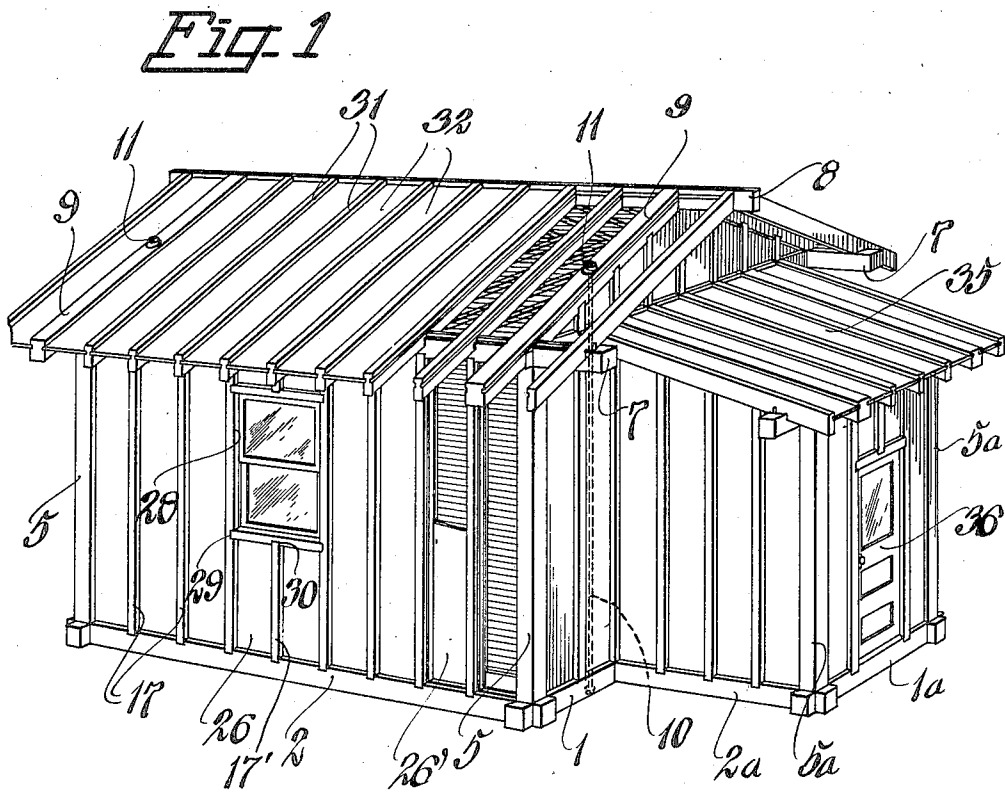

By

Inventor
Charles W. Andrews
Herbert E. Smith
Attorney

June 26, 1923.

1,459,761

C. W. ANDREWS

PORTABLE HOUSE

Filed April 12, 1921

2 Sheets-Sheet 2

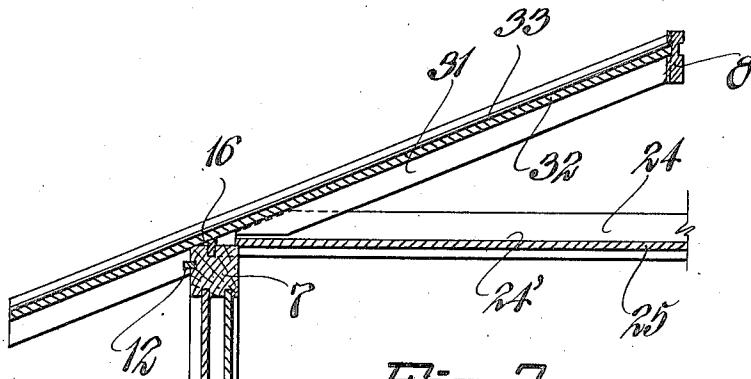

Fig. 3

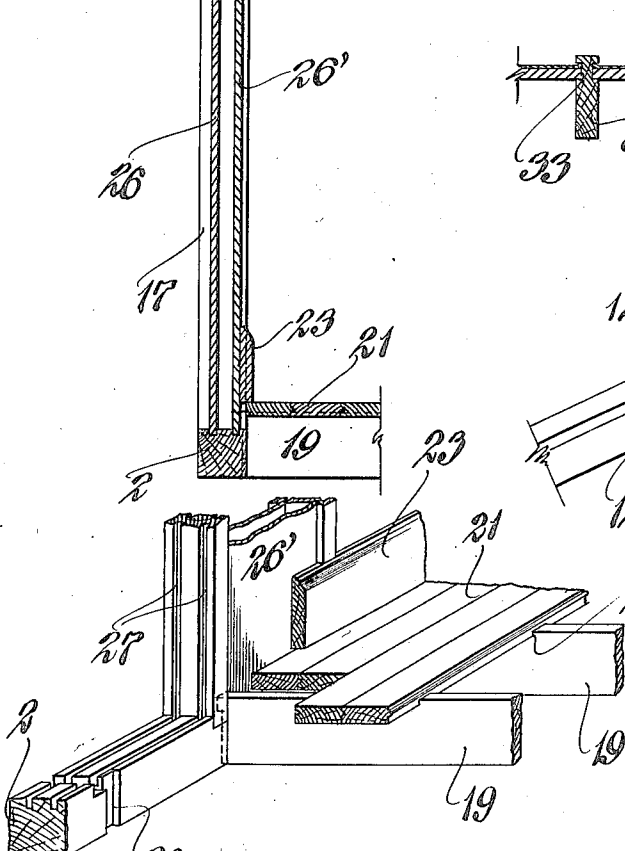

Fig. 4

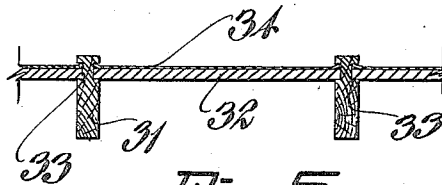

Fig. 5

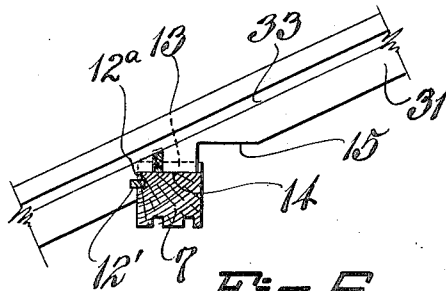

Fig. 6

Inventor
Charles W. Andrews

By
Herbert E. Smith
Attorney

UNITED STATES PATENT OFFICE.

CHARLES W. ANDREWS, OF SPOKANE, WASHINGTON.

PORTABLE HOUSE.

Application filed April 12, 1921. Serial No. 460,710.

To all whom it may concern:

Be it known that I, CHARLES W. ANDREWS, a citizen of the United States, residing at Spokane, in Spokane County and State of Washington, have invented certain new and useful Improvements in Portable Houses, of which the following is a specification.

My present invention relates to improvements in portable houses of that type which may be readily knocked down, or separable with facility, and again set up for use.

The primary object of the invention is the provision of a house of this character, of which the framework is so interlocked and tied together as to form a substantial structure for the sideboards, roof members, etc., and insure a weatherproof building, which in its erection avoids the use of nails, but is strongly and firmly braced against collapse or dislodgment of the roof section.

In the accompanying drawings I have illustrated one complete example of the physical embodiment of my invention, in which the parts are combined and arranged according to the best mode I have thus far devised for the practical application of the principles of my invention. While I have illustrated one type of structure, it will readily be understood that as the members or parts constituting the structure are standardized, these members may be incorporated in houses of different shapes and dimensions, but will retain the same architectural appearance, and while a one room house is illustrated it will be apparent that an offset or ell, or other features may be added to the structure shown.

Figure 1 is a perspective view of a portable, knock down, or separable house, erected according to the principles of my invention.

Figure 2 is a detail perspective view showing the ends of sills adapted to be jointed, and the relation of a corner stud and of an intermediate scantling or upright, to the sill.

Figure 3 is a transverse vertical sectional view of one half of the house, enlarged.

Figure 4 is a perspective view showing in detail the relation of floor sills, the flooring, washboard floor joists, etc., at one side of the house.

Figure 5 is a detail sectional, longitudinal view through a portion of the roof showing the relation of the rafters to the roof members.

Figure 6 is a detail sectional view showing the relation between the roof rafters and side beams.

In the preferred form of the invention as illustrated in the drawing, the several parts are fashioned in standardized form at the factory in order that the house may be shipped in knock-down or compact form, and erected with facility and a minimum of labor and time. Thus the end sills 1 and side sills 2 of the rectangular shaped house, are sawed and finished at the factory in predetermined sizes and shapes, of suitable timber, and near the ends of one pair of sills, as for instance, the end sills 1, a mortise 3 is cut in the upper face of the sill, with which a complementary mortise 4 in the lower face of the side sill, co-acts to form an interlocking joint at the corners of the sill frame of the house. At each of the four corners of the house are erected uprights or studs 5 of suitable height, and of approximately the dimensions of the floor sills and the lower ends of these corner studs are fitted in complementary mortises 6 in the upper faces of the side sills, near their ends, and extending transversely of the sills. All the joints are cut to fit neatly and the parts are dimensioned with accuracy to insure neat and workmanlike finish and to prevent dislodgment or displacement of parts.

The upper framework of the house is supported at the top of the four posts or corner studs, and comprises side beams and end beams indicated as 7, which are mortised at their ends on their undersides to engage the upper ends of the corner studs and are also mortised together to form corner joints similar to the sill joints described, and shown in Figure 2.

The beams 7 form an upper, rectangular frame for the roof support, and the gable roof is provided with a longitudinally extending, centrally located, and elevated ridge beam 8, from, which the two pairs of declining rafters 9, 9, extend, beyond the side beams 7 to form eaves. The front and rear, alined pairs of rafters 9 are located directly above the two end sills 1, 1 of the house, in the same vertical plane with these sills and with the corner studs, and the supporting framework of the house structure is firmly held together, braced, and secured by two pairs of tie bars 10.

One pair of tie rods is located at the front of the house and another pair at the rear, and the rods of the front and rear pairs are spaced equidistant from the longitudinal center of the structure. Each rod, or metal bar, is passed upwardly through an opening in the end sills, a socket being provided in the underside of the sill for the head of each tie bar or rod, and when the upper end beams 7 and roof rafters 9 are placed in position, these members, which are perforated for the purpose, are slipped over the threaded end of the tie rods. After the beams and rafters are in place, a nut 11, with suitable washers if necessary, is turned home on the threaded end of the tie rods projecting through the roof rafters. In this manner it will be apparent that the sill frame, the uprights or corner studs, the upper framework and the roof rafters are interlocked, braced, and tied together in a strong rigid structure as a support for the building.

In Figure 6 it will be seen that the roof rafters have additional fastening means for joining them to the side beams 7, where a dowel 12, squared in cross section, is forced into complementary grooves, one groove 12' transversely disposed in the rafter and the other groove 12^a extending longitudinally a sufficient distance in the outer face of the beam 7. At 13 in Figure 6 a mortise, indicated by dotted lines, is provided in the upper face of the beam 7, and the underside of the rafter is notched at 14 and 15, the former notch providing a seat in the mortise 13 for the rafter.

In Figure 6, and also in Figure 3, a tenon 16 is shown which forms a locking tongue, extending longitudinally of the beam 7, along a groove in its upper face, and through successive grooves in the intermediate roof members. Thus it will be apparent that the roof members are jointed to the upper side beams 7 at the outer sides thereof by dowels or tenons forming keys 12 in groove 12' to prevent upward strains on the roof, and at the top of these side beams the roof members are jointed to the upper side beams by tenons or keys 16 in grooves 12^a to hold the beam in the notches 14 against

relative movement of the roof and side beams. This jointing of the roof members and side beams is effective against the force of the wind under the eaves of the roof.

Between the respective corner studs, are spaced at regular intervals a series of intermediate uprights or scantlings 17, preferably made from smaller timber or lumber than the corner studs, and these scantlings, at their lower ends are jointed to the end sills and side sills in mortises 18 as best seen in Figure 2, it being understood that the upper ends of the scantlings are secured to the end and side beams in similar manner. The scantlings are placed in position before the upper framework, or beams 7, are secured, and the scantlings are firmly held between the beams and sills by the action of the tie rods 10.

The floor joists 19, as best seen in Figure 4 are seated at their ends in mortises 20 extending vertically at the inner sides of the end and side sills, and the joists as well as the sills may rest upon solid supports of approved form to provide a solid foundation for the superstructure or building. The flooring 21 is made up of tongue and groove material or boards each of the boards being mortised at 22 to register with the floor joists and be jointed thereto against displacement, and wash-boarding 23 may be provided around the edges of the flooring to make a finished appearance therefor.

The ceiling of the room, as shown in Figure 3 is made up of spaced ceiling rafters 24 having lateral grooves 24' extending longitudinally thereof, and between the ceiling rafters ceiling boards 25 are interposed, with their longitudinal edges fitted in the grooves 24'. The utility of the notch 15 in the rafters 9 of the roof will be apparent by an inspection of Figure 3 where it will be seen that the boards 25 extend horizontally into these notches against the vertical wall thereof.

The side walls are made up of side boards 26, arranged vertically between the scantlings 17, which latter are grooved as at 27 to receive the edges of the boards. A double thickness for the wall is desirable, and it will be seen that the scantlings have parallel grooves 27 to receive the inner and outer boards of the double-thick wall, the inner boards being designated 26' in the sectional view Figure 3.

In Figure 1 a window frame 28 is shown with a pair of sashes, and the frame is fitted in mortises 29 in the adjoining scantlings 17, while the bottom bar of the window frame is grooved or mortised at 30 to fit over the upper end of a short scantling 17', thus providing joints for securely holding the frame in position.

The opposite side wall of the house, not shown may also be provided with a window,

and if desirable a third window may be utilized at the rear in the end wall of the house.

5 The roof portions of the house are constructed in manner quite similar to the side and end walls, and between the front and rear main rafters 9 of the roof are arranged intermediate rafters 31, spaced at regular intervals as are the scantlings in the vertical walls, and between the intermediate rafters and main rafters are interposed roofing boards 32. Longitudinally extending grooves 33 are arranged laterally of the intermediate roof rafters to receive the edges of the roofing boards, and roofing felt or other material 34 in Figure 5 may be cemented or otherwise fastened to the outer surface of the boards to make the roof weatherproof.

20 For convenience and protection a vestibule as shown may be located at the front end of the house, the short sills 1^a and 2^a being jointed in manner similar to the longer sills, and the corner 5^a, boards 27 and roof structure 35 are similar to the corresponding members in the main portion of the house. Entrance to the house may be had through the door 36 of the vestibule.

30 The skilled mechanic will encounter no difficulty in erecting the house, and the unskilled person, after a little experience or instruction will be enabled to erect the structure with facility and convenience. The sills and floor joists are of course first placed in position and plumbed or leveled, after which the supporting frame for the structure is erected with due care and the tie rods fastened. The boards for the sides and roof portions may be placed in position between their grooved supports and then the vertical walls and roof portions, when separately assembled, may be properly located, the flooring, ceiling, and vestibule being subsequently put up to complete the building.

45 The double thick walls are preferable, of course, but in some instances the single wall will suffice for a house, and these wall boards may be of lumber fashioned to proper shape and dimensions, or they may be of composite material used for wall boards. The structure as thus described is well braced and joined by the interlocking joints between sills, studs and rafters, as well as scantlings, and the roof structure is retained against wind pressure by the dowels or keys which join the roof rafters with the upper side beams. The floor is also stiffened and

the floor boards held against longitudinal movement by their mortised connection with the floor joists.

Having thus fully described my invention, what I claim as new and desire to secure by Letters Patent is—

1. The combination in a knock-down house with an end sill and grooved side sill having complementary mortises and intercepting mortises in the upper face of the grooved side sill, of grooved studs seated in said intercepting mortises, an upper beam supported on said studs and provided with a groove in its under face, side boards having their edges in said grooved members, a roof member comprising notched rafters, means for keying said rafters to said upper beam, and tie rods extending through said rafters, beam and sill.

2. The combination with a side beam having a longitudinally extending lateral groove and spaced transverse mortises in its upper face, of a roof member comprising notched rafters having vertically extending transverse grooves fitted over said mortises and provided with transverse grooves in one wall of the notches, a lateral tenon engaging the lateral groove of the beam and the transverse grooves of the rafters and an upper tenon passing through said mortises and through vertically extending transverse grooves in the notched rafters.

3. In a knock down house, the combination with a sill frame, corner studs, and a complementary upper frame supported on said studs, of a ridge beam and laterally extending, notched roof rafters, detachable keys co-acting with means at the outer and upper sides of the side beams of said upper frame for forming temporary joints with said roof rafters, and vertically extending tie rods joining the sill frame and roof rafters and passing through said upper frame.

4. In a knock down house, the combination with a sill frame, corner studs and an upper frame, of a ridge beam and notched rafters having transversely extending pairs of grooves, a pair of grooves in the side beams of the upper frame complementary to said transverse grooves, a pair of locking keys engaging the registering grooves, and vertically extending tie rods joining the sill frame and rafters and passed through said upper frame.

In testimony whereof I affix my signature.
CHARLES W. ANDREWS.