

(21) Application No 9204872.7

(22) Date of filing 05.03.1992

(30) Priority data

(31) 9106789

(32) 02.04.1991

(33) GB

(71) Applicant

British Technology Group plc

(Incorporated in the United Kingdom)

101 Newington Causeway, London,
SE1 6BU, United Kingdom

(72) Inventors

John Alec Sidney Smith
Julian David Shaw

(74) Agent and/or Address for Service

Paul Dennis Cozens
British Technology Group plc, Patents Department,
101 Newington Causeway, London, SE1 6BU,
United Kingdom

(51) INT CL⁵

G01R 33/46, G01V 3/14

(52) UK CL (Edition K)

G1N N508 N522 N524 N526 N546 N553 N556
U1S S1310 S1348 S2196

(56) Documents cited

GB 2200462 A GB 1329776 A GB 1329647 A
US 4063150 A
Journal of Magnetic Resonance, Vol. 91(1991), pages
630-36

(58) Field of search

UK CL (Edition K) G1N
INT CL⁵ G01N, G01R, G01V 3/14 3/175
Online databases: WPI, INSPEC

(54) Method of and apparatus for NQR testing

(57) In carrying out a test (eg for detecting the presence of explosives or drugs) on a sample using nuclear quadrupole resonance (NQR) effects, measures are taken to ensure that variations in the characteristic NQR frequencies of materials due to environmental changes (eg in temperature or pressure) do not render the test ineffective. The measures include the use of a plurality of excitation frequencies or flip angles to cover the range within which an NQR frequency would be shifted by environmental changes. Spatial distribution of temperature within a sample may also be investigated.

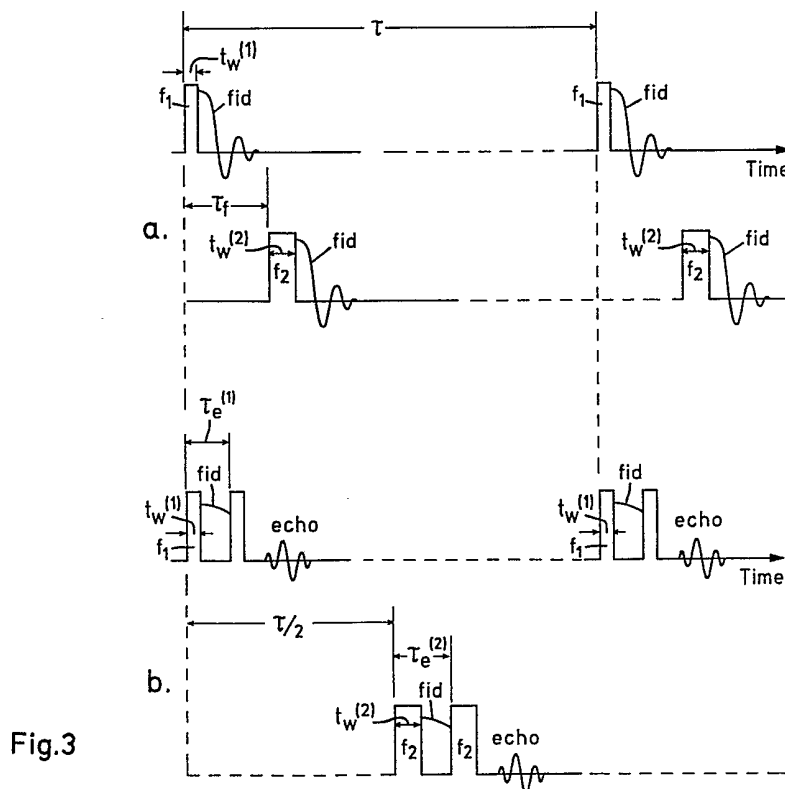

Fig.3

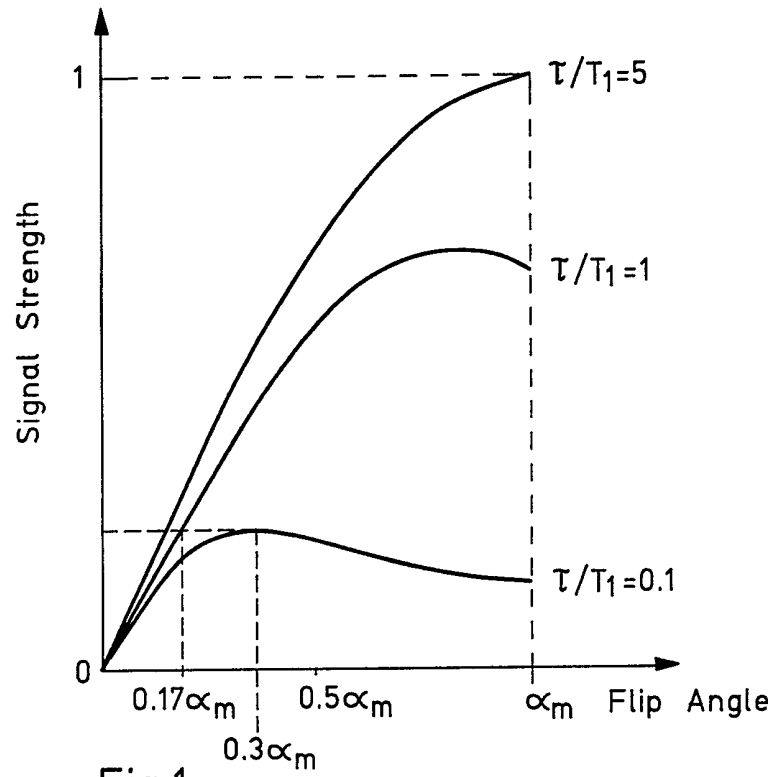

Fig.1

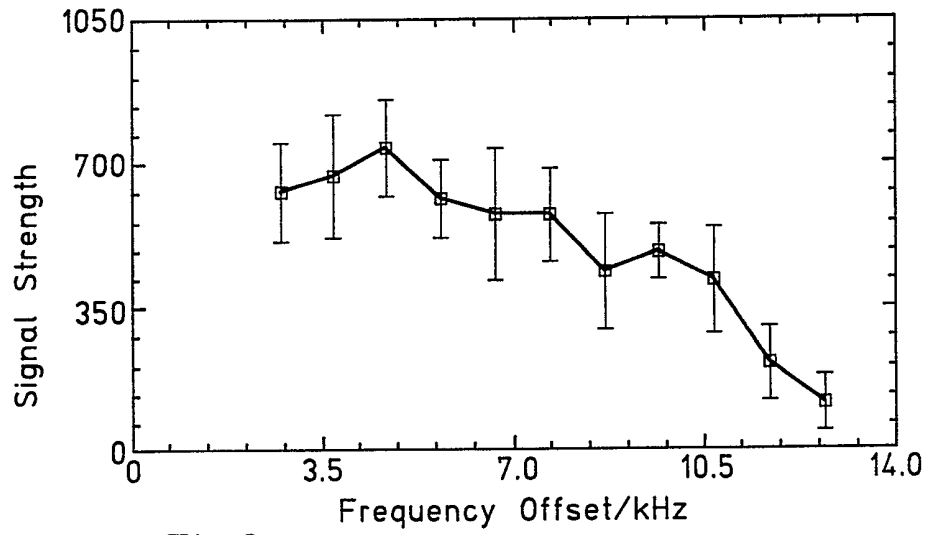

Fig.2

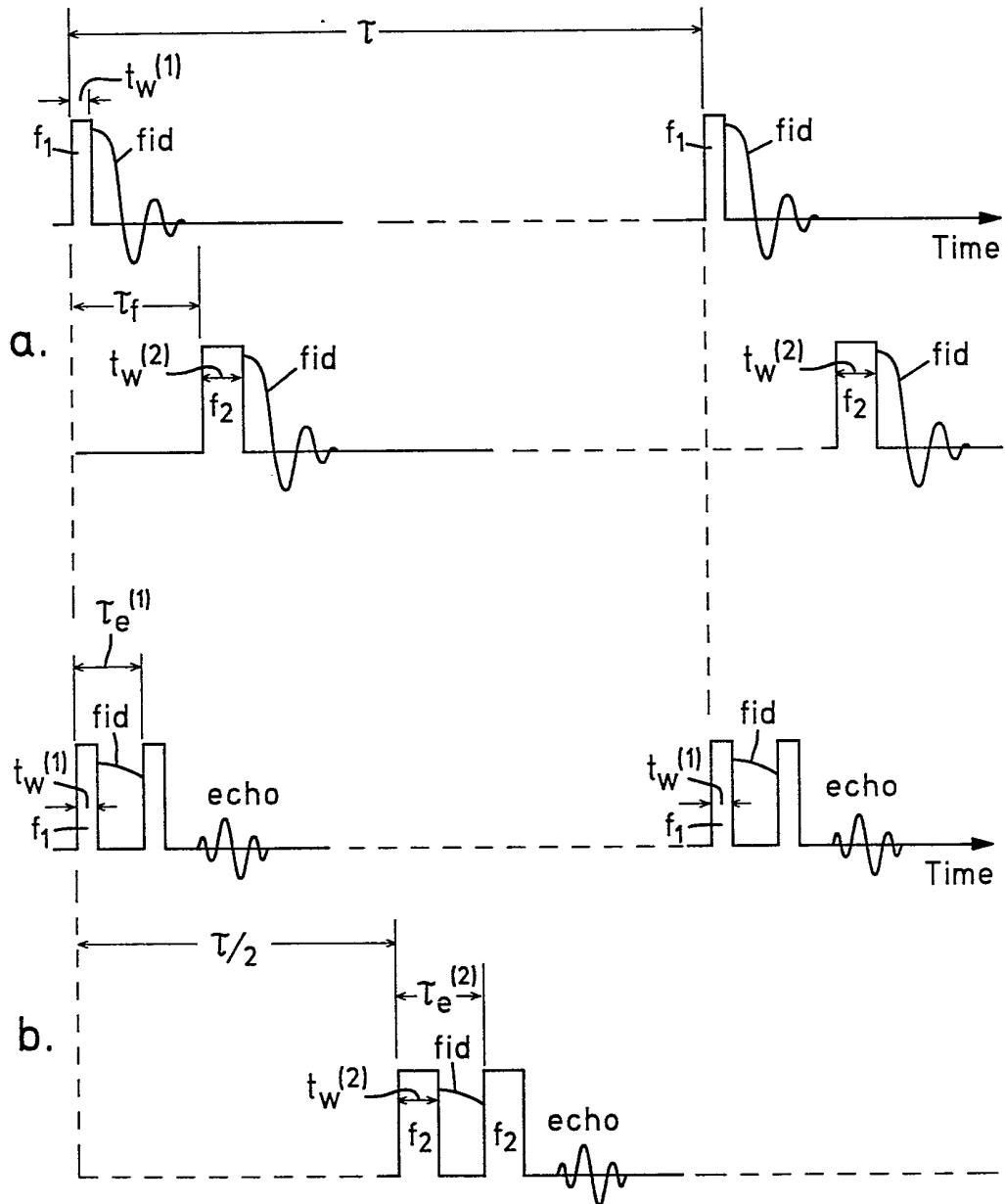

Fig.3

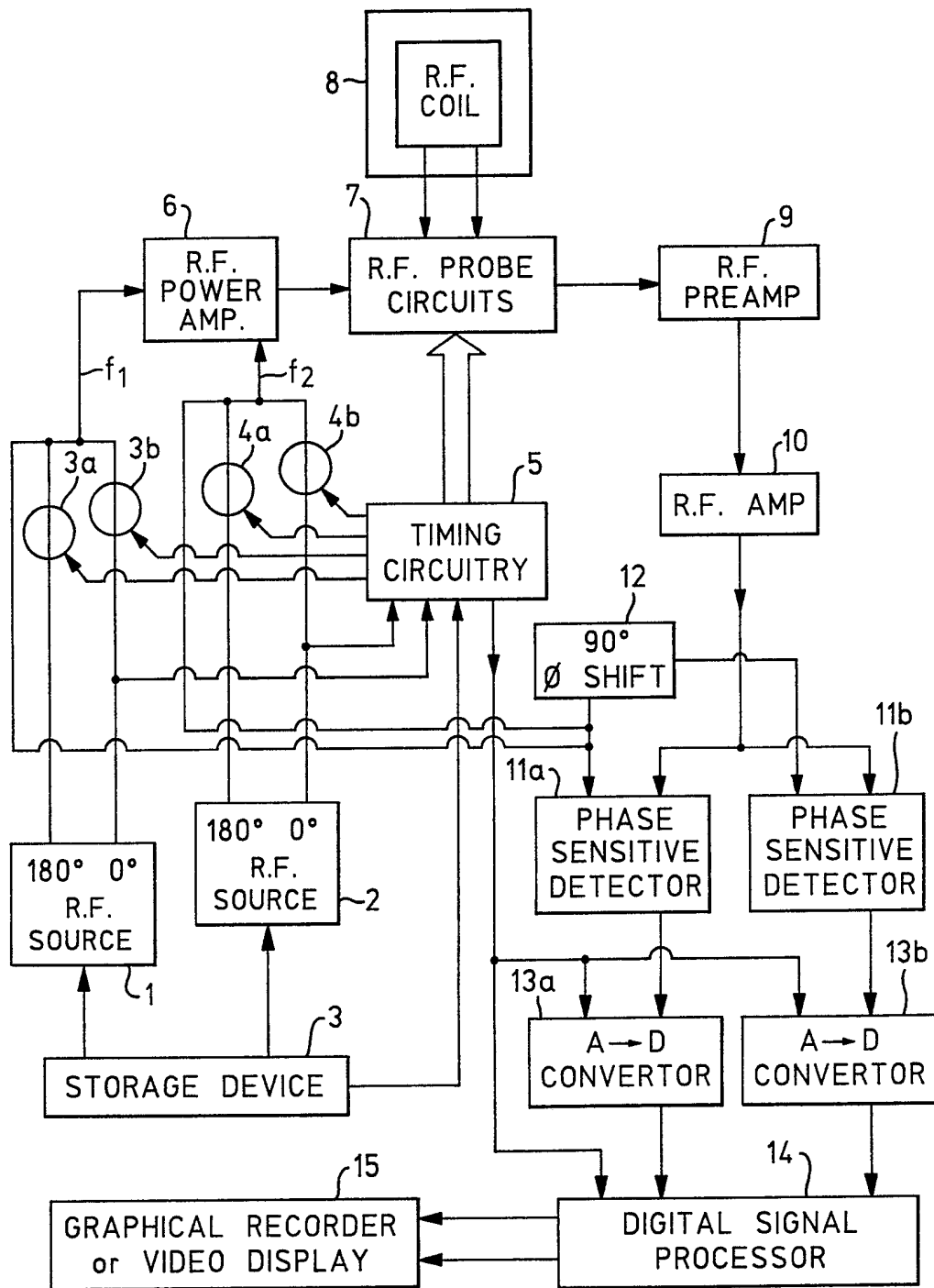

Fig.4

METHOD OF AND APPARATUS FOR NQR TESTING

This application claims priority from United Kingdom Patent Application No. 9106789.2, filed on 2nd April 1991, whose disclosure is incorporated herein by reference.

This invention relates to a method of, and apparatus for, Nuclear Quadrupole Resonance (NQR) testing a sample having at least one NQR property (particularly NQR resonance frequency or an NQR relaxation time, T_1 , T_2 , T_{2e} and T_2^*) which varies with a given environmental parameter, such as pressure, magnetic field or more particularly temperature. It also relates to a method of, and apparatus for, NQR testing for the presence of selected nuclei (particularly nuclei of integral spin quantum number, such as ^{14}N) in a sample. It also relates to a method of determining the spatial distribution of temperature within a sample.

As an example, the invention has application to the detection in the field of ^{14}N quadrupole resonance signals from the explosive RDX concealed in parcels or luggage or on the person, or deployed in explosive devices. As another example, it has application to the detection of concealed drugs, for instance at airports.

NQR measurements have the advantage that they do not require the sample to be placed in a strong magnetic field, and therefore do not require the large, expensive and sample-size limiting magnet structures which are needed for nuclear magnetic resonance (NMR) measurements.

Quadrupolar nuclei have a nuclear spin quantum number I equal to or greater than unity ($I \geq 1$). If they are half integral, the quadrupole interaction (in zero magnetic field) produces two doubly degenerate levels for the case of $I=3/2$ and one allowed transition ($1/2 \rightarrow 3/2$), three doubly degenerate levels for $I=5/2$ and two strongly-allowed ($1/2 \rightarrow 3/2$, $3/2 \rightarrow 5/2$) and one weakly-allowed ($1/2 \rightarrow 5/2$) transition, and so on. For integral spin nuclei, the most important of which is ^{14}N with $I=1$, there are usually three levels and three transition frequencies, dropping to one for

nuclei in axially-symmetric environments. All these transitions have a characteristic frequency and relaxation time (or times) which can be used to identify the substance under investigation. These frequencies and relaxation times do not depend on the presence of other substances, provided that they do not have transitions in the same frequency range.

Nuclear quadrupole resonance response signals are conventionally detected by means of pulsed radiofrequency (rf) radiation of the correct excitation frequency (ν_0) to excite the selected transition (at a resonance frequency ν_Q); a pulse of preset width t , rf field amplitude B_1 , and flip angle α generates a decaying signal immediately following the pulse known as a free induction decay (f.i.d.), and two or more pulses of pre-set widths and spacings can generate echoes. The pulse width which produces the maximum f.i.d. for a given quadrupolar nucleus in a solid powder is given the symbol t_m and the corresponding flip angle the symbol α_m (equivalent, for example, to a "90°" pulse in NMR).

Usually in NQR testing a repetitive pulse train is used with spacings between pulses, τ , which depend on the relaxation times T_1, T_2 and T_{2e} , and a number of f.i.d.'s and/or echoes is accumulated to provide the required sensitivity of detection. By "sensitivity of detection" is meant the number of selected nuclei (or amount of material) that can be detected at a given level of probability in a fixed volume of sample over a given test time. This sensitivity may be further improved by Fourier transformation of the accumulated signals to give an absorption spectrum, the area under which is then measured by integration between appropriate limits. A paper by N.E. Ainbinder *et al.* (Advances in Nuclear Quadrupole Resonance, 3, 1978, 67-130) provides information on this background state of the art.

The present invention seeks to provide an improved method of and apparatus for NQR testing.

According to the present invention, there is provided a method of NQR testing a sample having at least one NQR property

which varies with a given environmental parameter, comprising applying excitation to the sample to excite NQR resonance and detecting the NQR response signal, the excitation being such as to excite an NQR response signal which is detectable during the
5 detection step over a predetermined range of the environmental parameter.

The invention is based on our discovery that the NQR properties of a sample, such as resonance frequency (or frequencies), spin-lattice relaxation time (T_1), spin-spin
10 relaxation time (T_2), effective spin-spin relaxation time (T_{2e}) or free induction decay relaxation time (T_2^*), may vary considerably with a given environmental parameter, such as temperature, pressure or magnetic field, and that it is therefore necessary to take account of or compensate for these variations
15 when carrying out NQR tests to cover a predetermined range of the environmental parameter. Such compensation can have the unexpected advantage of considerably more sensitive tests than have hitherto been achieved.

Since the NQR testing would usually be carried out in the
20 field, (such as at an airport), the given predetermined range of the environmental parameter may typically be the range of that parameter likely to be encountered in the field (possibly the national or global average range or maximum range of that parameter). If the parameter is temperature, the predetermined
25 range may be $\pm 10^\circ\text{C}$ (possibly between 5°C and 25°C) or $\pm 20^\circ\text{C}$ (possibly between -10°C and $+30^\circ\text{C}$). The range may be as much as from -30°C (corresponding to arctic conditions) to $+40^\circ\text{C}$ (corresponding to desert conditions). In some industrial applications, considerably wider temperature ranges may be
30 encountered. If the environmental parameter is pressure, the predetermined range may be, for example, $\pm 1\%$ (corresponding to a typical average daily pressure range) or $\pm 5\%$ (corresponding to a maximum range).

As used herein, the term "detectable" preferably connotes a
35 signal/noise ratio which, within the measurement time of the

detection step, is significantly above the actual or expected noise levels, the degree of significance being determined, for example, by standard statistical methods, such as the upper Student's t-distribution.

5 Take, as an example, the detection of NQR signals from the explosive RDX concealed in parcels or luggage or on the person, with the environmental parameter being temperature. The NQR property resonance frequency is considered first. The three NQR resonance frequencies, ν_x, ν_y, ν_z , are all triplets due to crystal
10 effects; near 298 K, the highest set (ν_x) occurs at 5047 (N_1), 5192 (N_2), and 5240 (N_3) kHz. Between 240 and 340 K, their frequencies in kHz follow closely the equations

$$\begin{aligned} N_1 \quad \nu_Q^{(1)} &= 5148 - 0.223T - 0.000395T^2 \\ N_2 \quad \nu_Q^{(2)} &= 5277 - 0.139T - 0.000506T^2 \\ 15 \quad N_3 \quad \nu_Q^{(3)} &= 5332 - 0.108T - 0.000670T^2 \end{aligned} \quad (1)$$

where T is temperature.

If the RDX were in airport luggage, it might be subjected to a temperature variation of -30 to $+20^\circ\text{C}$ about a mean of 20°C (i.e. a variation from -10 to $+40^\circ\text{C}$). Different samples might be
20 at different temperatures, and/or the same sample might have a non-uniform temperature. Equation (1) predicts that $\nu_Q^{(1)}$ will vary significantly (between 5041 and 5062 kHz) for a temperature range of -10 to $+40^\circ\text{C}$. The present invention can, for example, provide that the excitation is such as to excite detectable NQR
25 resonance at resonance frequencies between 5041 and 5062 kHz, that is, over a temperature range likely to be experienced with airport luggage.

Considering now the NQR property spin-lattice relaxation time (T_1), we have discovered that the effects on the spin-lattice
30 relaxation time (T_1) of temperature (and also pressure) variations can be very significant. For example, with the RDX sample described above, over the temperature range -10 to $+40^\circ\text{C}$ it is believed that T_1 follows the expression

$$T_1 = aT^2 + be^{c/KT} \quad (3)$$

35 in which a and b vary according to the transition and c is about

70 kJ mol⁻¹. For N₁ in RDX T₁ varies, surprisingly, by a factor of approximately 8 between 5 and 25°C.

We have further discovered that one particularly important effect of the variation of T₁ is on the ratio τ/T_1 , where τ is the pulse spacing between consecutive excitation pulse repetitions (sometimes known as the pulse repetition time). As an example, reference is made to Figure 1, in which the variation of signal strength with flip angle (α) is shown for different values of τ/T_1 . Figure 1 is derived from equations derived by Vega (J. Chem. Phys., 1974, 61, 1099, Eq. IV-29) for spin-1 nuclei which predict the strength of the steady-state NQR signal in a powder as a function of τ for a given T₁; at a given ratio of τ/T_1 (<5) the signal is predicted to pass through a maximum as the flip angle is varied, this maximum moving to flip angles less than α_m and to lower signal strengths as the ratio of τ/T_1 drops below 5, as shown in Figure 1. Suppose, at $\tau/T_1=5$, the maximum f.i.d., corresponding to a flip angle α_m , has a relative strength of unity; at $\tau/T_1=0.1$, it has shifted to $0.3\alpha_m$ and has a relative signal strength of 0.25. For constant τ and at a constant flip angle α_m , a variation in τ/T_1 between 1 and 0.1 (an increase in T₁ by a factor of ten, corresponding, for N₁ in RDX, to a temperature increase near ambient of roughly 20°C) gives rise to an approximately 70% loss in response signal strength. Such a loss may render the response signal undetectable if it is overwhelmed by noise. The present invention can accommodate the variation of T₁ with an environmental parameter such as temperature.

Further, we have also discovered that the relaxation times T₂, T_{2e} and T₂^{*} may vary with temperature or pressure, although in general it is believed that this variation is less marked than with T₁. As is well-known, T₂ and T_{2e} are spin-spin relaxation times which are relevant to the generation of echoes. T₂^{*} is relevant to the generation of f.i.d.'s. One important effect of the variation of the spin-spin relaxation times is on the ratios τ_e/T_2 , τ_e/T_{2e} and τ_f/T_2^* , where τ_e is the pulse spacing between

the pulses used to generate one or more echoes and τ_f is the pulse spacing between the pulses (possibly at different frequencies) used to generate f.i.d.'s. Variation of these ratios is important because response signal strength is a function of τ_e/T_2 , τ_e/T_{2e} and τ_f/T_2^* , an exponential being one form of function which is often encountered. Again, the present invention can accommodate the variation of such relaxation times with an environmental parameter such as temperature.

In putting the invention into effect, if the NQR property under consideration is resonance frequency, the excitation may be at least one excitation pulse (e.g. a simple or composite pulse) at a single excitation frequency, the or each pulse having a power spectrum sufficient to excite a detectable NQR resonance response signal over the range of resonance frequency corresponding to the range of the environmental parameter. Thus all frequencies to be encountered lie within (preferably well within) the power spectrum of the excitation pulse or pulses. A disadvantage of this approach is the high rf powers required.

Therefore, it is preferred that the excitation is applied at a plurality of different excitation frequencies so that a detectable NQR resonance response signal can be excited over the range of resonance frequency corresponding to the range of the environmental parameter. This can be achieved, for instance, by applying separate excitation pulses at different frequencies, or by frequency modulating the fundamental frequency of one or more excitation pulses, or by varying the frequency of each individual pulse.

Now the signal strength for any transition varies according to the relative values of the off-set frequency $\Delta\nu_0$ and the precessional frequency ν_1 in the rf B_1 field:-

$$\nu_1 = \frac{\omega_1}{2\pi} = \gamma_N B_1/2\pi \quad (2)$$

where γ_N is the gyromagnetic ratio (1.932×10^7 rad s^{-1} T $^{-1}$ for ^{14}N nuclei). The strength falls off significantly as soon as $\Delta\nu_0$ becomes much larger than ν_1 . For the N_1 resonance at 5047 kHz in

RDX, the variation is shown in Figure 2 for a $60\mu\text{s}$ rf pulse of B_1 amplitude corresponding to a value of ν_1 of about 9 kHz; the diminution in signal strength with increasing $\Delta\nu_0$ becomes important when $\Delta\nu_0$ is greater than roughly 9 kHz.

5 In the present invention, by applying the excitation to the sample at a plurality of different frequencies so that a detectable NQR resonance response signal can be excited over the range of resonance frequency corresponding to the range of the environmental parameter, the maximum frequency off-set can be
10 reduced so as to be kept within acceptable limits. From the point of view of keeping the maximum frequency off-set within acceptable limits, the number of different frequencies at which the excitation is applied should be as large as possible. On the other hand, a conflicting requirement is that the greater the
15 number of frequencies, the longer may be the NQR test.

In putting the invention into effect, if the NQR property under consideration is a relaxation time, then the excitation is preferably applied as a series of excitation pulses, at a plurality of different pulse spacings and/or so as to produce a
20 plurality of different flip angles, so that a detectable NQR resonance response signal can be excited over the range of the relaxation time corresponding to the range of the environmental parameter.

This is based on our discoveries, as described above, of the
25 effects on the spin-lattice, spin-spin and f.i.d. relaxation times of, for example, temperature and pressure variations and of the effect that these have on signal strength.

If the relaxation time under consideration is T_1 , the pulse spacings (in this case the pulse repetition times, τ) and/or flip
30 angles can be chosen according to the principles explained in relation to Figure 1 to excite a detectable NQR response signal over the entire T_1 range of interest. If the relaxation time is T_2 , T_{2e} or T_2^* , since signal strength is a function of the ratio of pulse spacing to the relevant relaxation time as well as a
35 function of flip angle, pulse spacing (in this case the spacing

referred to as τ_e or τ_f) may be varied in direct proportion to the relevant relaxation time, or else flip angle may be appropriately adjusted, to excite a detectable NQR response signal over the entire range of interest of the relevant
5 relaxation time.

It is advantageous that the NQR testing takes into account variations both in resonance frequency and T_1 caused by variations in the environmental parameter or parameters. To achieve this, preferably the excitation is applied as a
10 repetitive series of excitation pulses at each of a plurality of different excitation frequencies, the pulse repetition time being the same for each series, the flip angle being different for each series. One particular advantage of this arrangement is that the pulses associated with the different frequencies can be
15 interleaved without a pulse at one frequency interfering with the response signals generated by pulses at other frequencies.

If it is desired to take into account variations in T_2 or T_{2e} , and the excitation is applied as a series of excitation pulses at each of a plurality of different excitation
20 frequencies, each series including a plurality of pulses for generating echoes, then the spacing between each of the plurality of the pulses (τ_e) is preferably different for each series (and chosen according to the variation of T_2 or T_{2e} with the environmental parameter). The variation in T_1 can thus still be
25 compensated for by varying flip angle.

If it is desired to take into account variations in T_2^* , and the excitation is applied as a series of excitation pulses at each of a plurality of different excitation frequencies, for generating detectable f.i.d.'s, pulses at the different
30 frequencies are preferably applied at staggered spacings (τ_f) chosen according to the variation of T_2^* with the environmental parameter. τ_f may be some multiple of (say two or three times) T_2^* , such as allows a reasonable proportion of the f.i.d. produced by the preceding pulse to be detected before the
35 succeeding pulse is applied, without being so long as to unnecessarily slow down the test.

These techniques for taking into account variations in T_2 , T_{2e} or T_2^* are particularly advantageous when combined with the aforementioned technique for taking into account variations in resonance frequency and T_1 . In this event, flip angle adjustment
5 can be reserved for compensating for T_1 variations whilst pulse spacing adjustment can be reserved for compensating for T_2 , T_{2e} or T_2^* variations. This leads to experimental simplicity.

Preferably, the excitation is such that the NQR response signal/noise ratio would be substantially equal at at least two
10 differing values of the environmental parameter. It is preferable that the signal/noise ratio would be substantially equal at as many differing values of the environmental parameter as possible, and that it would be substantially constant between these values (that is, so that it would be substantially constant
15 over the range of the environmental parameter). "Substantially" is to be interpreted in the context of the large variations in signal/noise ratio which may be occasioned by changes in an environmental parameter. Thus by "substantially equal" and "substantially constant" may be meant a minimum signal/noise
20 level within 50%, 60% or preferably 75% of a maximum signal/noise level.

A particular advantage of the NQR response signal/noise ratio being substantially equal at at least two differing values of the environmental parameter and preferably substantially constant
25 over the range of the environmental parameter is that it facilitates accurate NQR testing for the presence of selected nuclei in a sample, such as would be required in the example of RDX detection above. The invention envisages that an alarm signal would be produced if a predetermined threshold of
30 detection were exceeded. This threshold might typically be derived from a number of tests carried out on a variety of substances other than the substance of interest in order to determine expected levels of background noise. The threshold would typically be set above these expected levels (preferably
35 several standard deviations above these levels). By providing

that the signal/noise ratio remains substantially constant over the range of the environmental parameter, the effect of the threshold will also be substantially constant. In other words, the sensitivity of detection will be substantially constant.

5 Substantial equality in the signal/noise ratio could be obtained by "post-processing" of the detected NQR response signal by some form of noise filter. However, it is more preferably obtained by "pre-processing", by appropriate adjustment of the response signal strengths. It will be understood that the
10 "noise" component of the signal/noise ratio need not be specifically measured. It can usually be assumed that noise will be virtually invariant across the range of the environmental parameter. If this is so, then maintaining the signal/noise ratio substantially equal reduces to a requirement to maintain
15 the NQR response signal strength substantially equal. If noise actually varies across the range, then a suitably varying threshold might be appropriate.

The invention envisages that the NQR response signal/noise ratio may be rendered substantially equal at the at least two
20 differing values of the environmental parameter by compensation for resonance frequency, T_1 , T_2 , T_{2e} or T_2^* variations. Indeed, compensation may be for a combination of or even all of such variations.

If the NQR resonance frequency of the sample varies with the
25 given environmental parameter, and the excitation is applied at a plurality of different excitation frequencies, it is preferred that the number and spacing of these frequencies is such that the NQR response signal/noise ratio is substantially constant over the range of the environmental parameter. In the example given
30 above, if $\nu_Q^{(1)}$ lies between 5041 and 5062 kHz over a temperature range of -10 to $+40^\circ\text{C}$, this range of $\nu_Q^{(1)}$ can be covered by the use of two excitation pulse sequences, one at a radio frequency of 5048 kHz and the other at 5055 kHz; the maximum off-set at any temperature within the specified range is $\Delta\nu_Q = 7$ kHz, and,
35 with this value, either one pulse train or the other will give

optimum or near-optimum sensitivity of detection for a pulse width of $60 \mu\text{s}$ and $\nu_1 \geq 9 \text{ kHz}$, with the NQR response signal strength remaining substantially constant. On the assumption that noise is constant across the frequency range of interest, the signal/noise ratio and hence the sensitivity of detection
5 also remains substantially constant.

The spectrometer in this example is tuned to a mean frequency of 5051.5 kHz , and the probe Q factor and receiver band width are selected so that signal responses at 5041 and 5062 kHz are
10 amplified to the same extent. After separate Fourier transformation of the accumulated f.i.d.'s or echoes from both rf pulse trains, the absorption mode signals from each are then separately integrated between frequency limits pre-set to ensure that the majority of the spectral line lies within the
15 integration limits anywhere in the frequency range from 5041 to 5062 kHz ; in this example, integration limits of (say) 2 to 10 kHz will accept a signal from one or other of the excitation frequencies of $5048, 5055 \text{ kHz}$. The lower limit of 2 kHz is selected to reduce the effects of changes in the base-line
20 response signal. The integrals from both rf sequences are then separately monitored, or added to give the summed output. It will be understood that, in the example described, excitation pulses at different excitation frequencies may in some circumstances excite a single resonance frequency to a
25 significant extent. The summed output of such pulses is not in this experiment nearly as great as if pulses were applied separately in isolation from each other, and their outputs were then summed, because the first pulse saturates subsequent response signals (although clearly this may not always be the
30 case).

Preferably, for simplicity, the excitation is applied at $n-1$ equally spaced frequencies, where n is the nearest integer satisfying the equation

$$n \geq \Delta\nu_0 / \Delta\nu_{\text{off}},$$

35 where $n \geq 2$, $\Delta\nu_0$ is half of the value of the resonance frequency

range corresponding to the range of the environmental parameter, and $\Delta\nu_{\text{off}}$ is approximately equal to the precessional frequency (ν_1) (and is therefore a measure of the maximum frequency off-set above which significant reductions in response signal/noise ratio would be observed for a given resonance frequency).

The lowest frequency may therefore be $\nu_0 - \Delta\nu_0 / 2 + \Delta\nu_{\text{off}}$, the next $\nu_0 - \Delta\nu_0 / 2 + 2\Delta\nu_{\text{off}}$, and so on. In the example given above, the integration limits for the Fourier transformed spectrum can then be set between (say) 2 kHz and $\Delta\nu_{\text{off}}$. The integrals from all pulse sequences may then be monitored consecutively or summed to obtain the final output. The receiver band width and Q-factor of the rf coil would be selected to provide constant sensitivity over the frequency range from $\nu_0 - \Delta\nu_0$ to $\nu_0 + \Delta\nu_0$.

If a relaxation time of the sample varies with the given environmental parameter, and the excitation is applied as a series of excitation pulses at a plurality of different pulse spacings and/or so as to produce a plurality of different flip angles, the pulse spacings and/or flip angles are preferably such that the NQR response signal/noise ratio is substantially constant over the range of the environmental parameter. This can facilitate accurate NQR testing for the presence of selected nuclei in a sample, as discussed previously.

If the NQR resonance frequency of the sample also varies with the environmental parameter and the excitation pulses are applied at a plurality of different excitation frequencies, the pulse spacings and/or flip angles associated with the excitation frequencies preferably are such as to produce an NQR response signal of substantially equal signal/noise ratio at the respective values of the environmental parameter at which the NQR resonance frequency equals the respective excitation frequency. This affords a particularly simple way of compensating for the variation of resonance frequency and relaxation time.

As an example, the case where only two excitation frequencies are utilised is considered. To ensure that the sensitivity of detection at two different frequencies with different spin-

lattice relaxation times remains the same, it is necessary to change the flip angle α according to Vega's equations, either by using different pulse shapes (especially widths) or different rf powers at the two frequencies. The method of selection is
5 illustrated diagrammatically in Figure 1 for the steady-state signal generated by pulse trains of two different ratios of τ/T_1 . If τ/T_1 at one frequency and temperature is equal to 1, setting the flip angle to $0.17 \alpha_m$ will give the same response signal strength as at another frequency and temperature at which
10 $\tau/T_1 = 0.1$ and the flip angle is set to $0.3 \alpha_m$. Thus the same number of accumulations at either frequency will give rise to the same integrated signal strength and therefore generally the same signal/noise ratio.

The flip angles selected will only be correct at the spot
15 frequencies of the excitation pulses, but deviations at intermediate frequencies will be reduced in their effect if integrated signal strengths from consecutive irradiation frequencies are summed. In practice, inhomogeneities in the B_1 field and varying flip angles caused by temperature shifts
20 between samples and/or temperature variations within a sample will also ensure that the idealised predictions are not followed exactly. It may therefore be necessary in a given case to apply small adjustments to the predicted flip angles to allow for such effects with a given coil geometry and NQR frequency.

25 Whilst the excitation might suitably take the form of simple rectangular pulses, it may be preferable that the excitation includes at least one excitation pulse which is so shaped as to produce a response signal whose strength is substantially constant over a limited resonance frequency range. Simple
30 rectangular pulses typically have a curved response signal characteristic like that shown in Figure 2; a relatively flat characteristic afforded by a suitably shaped pulse would have the advantage that the sensitivity of detection would be more uniform over the limited resonance frequency range. Suitable pulse
35 shapes will be known to the skilled person. One particularly

suitable shape is an Hermite pulse (see the paper by M. McCoy and W.S. Warren, J. Mag. Res., 1985, 65, 178), which has the additional advantage of requiring less power than a rectangular pulse to generate a given B_1 field.

5 The invention extends to apparatus for NQR testing a sample having at least one NQR property which varies with a given environmental parameter, comprising:-

storage means in which is stored information on how the or each NQR property varies over a predetermined range of the
10 environmental parameter;

means for applying excitation to the sample to excite NQR resonance;

means for detecting the NQR response signal; and

means, responsive to the information stored in the storage
15 means, for controlling the applying means to excite an NQR response signal which is detectable by the detection means over a predetermined range of the environmental parameter.

The invention further extends to a method of NQR testing for the presence of selected nuclei in a sample, comprising:

20 deriving an NQR response signal from the sample in such a way that the signal/noise ratio would be substantially equal at at least two differing values of an environmental parameter; and

producing an alarm signal from the NQR response signal in dependence on whether a predetermined threshold of detection has
25 been exceeded.

As alluded to earlier, by this arrangement, a particularly accurate and sensitive NQR test for the presence of selected nuclei can be carried out, since the signal/noise ratio will have the same significance in relation to the threshold value at the
30 two or more differing values of the environmental parameter.

This aspect of the invention extends to apparatus for NQR testing for the presence of selected nuclei in the sample analogous to the method described immediately above. All the features of the invention as a whole described above apply to
35 this aspect of the invention.

The invention extends to a method as aforesaid of NQR testing a sample having at least one NQR property which varies with a given environmental parameter, the method being for determining the spatial distribution of temperature within a sample, wherein
5 a relaxation time (T_1 , T_2 , T_{2e} , T_2^*) varies with temperature, and such spatial distribution is determined according to the variation of relaxation time within the sample.

This method is based on our discovery that relaxation time varies substantially with temperature. It can provide a
10 sensitive technique for temperature distribution imaging.

It is preferred that the spatial variation distribution of temperature is determined according to the variation of the spin-lattice relaxation time, T_1 , within the sample, since we have found that this relaxation time may be most sensitive to
15 temperature. One preferred way of putting this method into practice is to apply a series of excitation pulses to the sample in which the pulse repetition time is varied whilst the flip angle is kept constant. The pulses would be applied, for instance, in the presence of a weak magnetic field to provide
20 spatial encoding of the data. Decoding of the data can be carried out by well-known techniques such as Fourier analysis. T_1 data could be converted to temperature data via a look-up table.

The spatial distribution of temperature may also be
25 determined according to the variation of a spin-spin relaxation time within the sample. This method would be put into practice by varying the spacing (τ_e) between pulses whilst keeping the flip angle constant, in order to encode spatially data relating to the relevant relaxation times. It is thought that this
30 technique may apply to the times T_2 and T_{2e} but not to the time T_2^* , since in the case of T_2^* there is no relevant pulse spacing which can be varied.

The invention extends to a method for detecting the presence within a larger article of a specific substance containing
35 quadrupolar atomic nuclei, wherein the irradiation can allow for

resonance frequency shifts caused by $\pm 20^{\circ}\text{C}$ temperature variations. It also extends to a method for detecting the presence within a larger article of a specific substance containing quadrupolar atomic nuclei, wherein the power spectrum of the irradiation pulses provides substantial power within about 5 0.1% of any frequency to which NQR resonance may be shifted by any environmental conditions likely to apply to the article. The irradiation pulses may be at one or more frequencies equal or close to (maybe within 0.1% of) a resonant frequency of 10 quadrupolar nuclei within the substance to be detected.

The substance may be drugs, for instance heroin or cocaine, or explosives, for instance HMX, RDX, PETN, or TNT. The quadrupolar nuclei in these substances may be ^{14}N . The environmental conditions are such conditions as temperature, 15 pressure or magnetic fields. One use for these methods is in the examination of airline baggage or airfreight, where in a typical case ± 10 kHz resonance frequency shifts may be caused by $\pm 20^{\circ}\text{C}$ temperature variations. For the detection of the explosive RDX a suitable resonance frequency is 5.191 MHz; rf drive signals 20 having a power spectrum of width 18 kHz at half height may be used to allow for the effects of the $\pm 20^{\circ}\text{C}$ temperature variation.

For any aspect of the invention, apparatus features analogous to the described method features may be provided.

Preferred features of the invention will now be described, by 25 way of example, with reference to the accompanying drawings, in which:-

Figure 1 is a plot of the steady-state NQR response signal strength against flip angle for differing values of the ratio τ/T_1 ;

30 Figure 2 is a plot of NQR response signal strength against frequency off-set for a $60 \mu\text{s}$ excitation pulse ($\nu_1 \approx 9$ kHz);

Figures 3 are timing diagrams for two embodiments of the invention; and

Figure 4 is a block diagram of NQR apparatus used in the 35 present invention.

Referring to the timing diagram of the first embodiment of the invention shown in Figure 3(a), two radio frequency pulses (either simple or composite) of width $t_w^{(1)}$ and $t_w^{(2)}$ and of differing frequencies f_1 and f_2 are repeated at pulse repetition
5 times τ ($\tau \gg t_w$) which are much longer than the longer T_1 - say $\tau = 5T_1$ - to ensure full signal recovery between pulses; phase shifts of alternate pulses or suitable combinations of pulses of width t_w and $2t_w$ may be used to eliminate probe ringing. After
10 phase-sensitive detection and manipulation of the appropriate signals, the residual oscillations can be made to cancel and only the true NQR response signal is observed. Since τ is much longer than either T_1 value, no T_1 compensation is necessary (see Figure 1).

The overall time of the test is limited by the longer T_1 ; if
15 $\tau = 5T_1$ (where T_1 is the longer T_1 value) and the allowed observation time is T_{obs} , the maximum number of accumulations possible is $N = T_{obs} / (t_w + \tau) = T_{obs} / (t_w + 5T_1)$. Signal/noise ratio is proportional to \sqrt{N} , so that it is important to set the pulse repetition time τ so that τ is not significantly longer
20 than $5T_1$; otherwise information is lost. As mentioned previously, a restriction on the separation, τ_f , between the two pulses is that τ_f should exceed, say, $2T_2^*$ or $3T_2^*$, in order to allow the f.i.d. from the first pulse to decay substantially before the second pulse is applied. Since T_2^* may vary, for
25 example, with temperature, it may be important to adjust τ_f in the manner described previously to compensate for this.

In an alternative form of this first embodiment, the pulse repetition time τ is made less than $5T_1$ (where T_1 is now the shorter T_1 value) and the pulse width and/or rf power adjusted to
30 produce flip angles which are less than α_m and which allow for the variation of τ/T_1 with temperature, as described earlier in relation to Figure 1. That is, the excitation is such as would produce equal signal strengths at the temperatures at which f_1 and f_2 are the resonant frequencies. The signals are weaker than
35 when $\tau/T_1 \approx 5$, but more can be accumulated in a given time and a lower rf power is required.

In a second embodiment of the invention shown in Figure 3(b), case (b), series of excitation pulses are applied at two different frequencies f_1 and f_2 to excite separate echoes at staggered intervals. The pulse repetition time τ can be equal to
5 or less than $5T_1$ (as with the two forms of the first embodiment), and the pulse width and/or rf power may be adjusted if necessary to produce flip angles which allow for the variation of τ/T_1 with NQR resonance frequency, as described earlier in relation to Figure 1. The echoes at $\tau/T_1 < 5$ are weaker than when $\tau/T_1 \approx 5$, but
10 more can be accumulated in a given time. In order to compensate for the variation of T_2 with temperature, it may be important to vary the pulse spacings between the excitation pulses (τ_e) from f_1 to f_2 so that the ratio τ_e/T_2 would be constant at the temperatures at which f_1 and f_2 are the resonant frequencies.

15 Interleaving of the pulses in the way shown in Figure 3(b) is possible if $\tau \gg T_2$. In the embodiment shown in Figure 3(b) the pulses are at only two frequencies, f_1 and f_2 . However, several different radiofrequencies could be interleaved to cover as wide a temperature/frequency range as is required, consistent with the
20 band width of the rf probe and receiver.

In a third embodiment of the invention, case (c) (not shown), a long series of short high-power rf pulses at a single frequency and appropriate phases is used with a spacing τ_e less than the spin-spin relaxation time T_2 ; the responses are then observed as
25 a train of echoes between each pulse and decay with a time constant T_{2e} , where in favourable cases $T_{2e} \gg T_2$. These echoes are sampled and accumulated to provide the final signal. The whole process is then repeated at one or more different frequencies. This embodiment is particularly advantageous where
30 T_{2e} is long. It will be appreciated that any temperature variation of the relaxation times, T_1 , T_2 and T_{2e} , may need to be allowed for.

NQR apparatus for putting the invention into effect will now be described with reference to Figure 4. Two radio frequency
35 sources, 1 and 2, provide pulsed rf excitation pulses at

frequencies of f_1 and f_2 , to cover the frequency range produced by differing sample temperatures. f_1 and f_2 are selected according to the output of a storage device 3, in which is stored information on how the NQR resonance frequency, spin-lattice relaxation time, T_1 , spin-spin relaxation times, T_2 , T_{2e} and f.i.d. relaxation time, T_2^* of the sample vary with temperature and/or pressure. More frequencies may be necessary if the frequency range is larger than a few tens of kHz. Alternatively, a switched frequency synthesizer could be used, provided that the switching time was much less than the f.i.d. time T_2^* (for RDX, this quantity is about 0.8 ms at 298K).

The rf sources 1 and 2 have normal and phase-shifted outputs (typically 0° and 180°) connected through rf gates 3a,b and 4a,b which are controlled by master timing circuitry 5, which also adjusts the width of each rf pulse according to the excitation frequency, the pulse repetition time, τ , and the spin-lattice relaxation times stored in the storage device. The rf pulse sequences pass to an rf power amplifier 6 of constant output over the frequency range of the rf sources, and thence to an rf probe 7 and rf coil (or coils) 8 surrounding the sample. The rf probe receives inputs from the timing circuitry 5 so that the tuning elements can be adjusted to take account of differing excitation frequencies f_1 , f_2 , etc., which may be necessary for high-Q rf coils. The coils produce a uniform field over the working region of the probe. The signals generated pass to a pre-amplifier 9 and rf amplifier 10 of sufficient band width to amplify at constant gain all NQR response signal frequencies likely to be encountered. The response signals are detected in two separate phase-sensitive detectors 11a,b, to generate in-phase and quadrature outputs.

The output of gates 3a,b, controlling pulses of radio frequency f_1 (channel 1) is connected as a reference signal to detector 11a and through a 90° phase-shift network 12 to detector 11b. Outputs from the detectors 11a,b are sampled and digitised by analogue-to-digital converters 13a,b under the

control of the timing circuitry 5 and then passed to a digital signal processor 14 for display in graphical recorder or video display 15.

5 The output of gates 4a,b controlling pulses of radio frequency f_2 (channel 2) is connected as a reference signal to the detector 11a and through the 90°-phase-shift network 12 to the detector 11b. Outputs from the detectors 11a,b are sampled and digitised by the analogue-to-digital convertors 13a,b and stored in a separate memory from the signals in channel 1, this selection being controlled by trigger pulses from the timing
10 circuitry 5. After processing in the digital signal processor 14, both signals are either separately displayed, or summed before display to provide the output of the instrument. An alarm (not shown) may then sound if this signal exceeds a
15 pre-set threshold.

It will of course be understood that the present invention has been described above purely by way of example, and modifications of detail can be made within the scope of the invention.

CLAIMS

1. A method of NQR testing a sample having at least one NQR property which varies with a given environmental parameter, comprising applying excitation to the sample to excite NQR resonance and detecting the NQR response signal, the excitation
5 being such as to excite an NQR response signal which is detectable during the detection step over a predetermined range of the environmental parameter.
2. A method according to Claim 1 wherein the NQR resonance
10 frequency of the sample varies with temperature and the excitation is such as to allow for resonance frequency shifts caused by $\pm 20^{\circ}\text{C}$ temperature variations.
3. A method according to Claim 1 or 2 wherein the NQR resonance
15 frequency of the sample varies with the given environmental parameter and the excitation is applied at a single excitation frequency, the excitation being sufficient to excite a detectable NQR resonance response signal over the range of resonance frequency corresponding to the range of the environmental parameter.
- 20 4. A method according to Claim 1 or 2 wherein the NQR resonance frequency of the sample varies with the given parameter and the excitation is at a sufficient number of excitation frequencies that every value of resonance frequency in a range corresponding to the range of the environmental parameter is within 0.1% of an
25 excitation frequency.
5. A method according to Claim 1 or 2 wherein the NQR resonance frequency of the sample varies with the given environmental parameter and the excitation is applied at a plurality of
30 different excitation frequencies so that a detectable NQR resonance response signal can be excited over the range of resonance frequency corresponding to the range of the environmental parameter.
6. A method according to any of the preceding claims wherein a
35 relaxation time of the sample varies with the given environmental parameter, and the excitation is applied as a series of

excitation pulses, at a plurality of different pulse spacings and/or so as to produce a plurality of different flip angles, so that a detectable NQR resonance response signal can be excited over the range of the relaxation time corresponding to the range
5 of the environmental parameter.

7. A method according to Claim 6 wherein the excitation is applied as a repetitive series of excitation pulses at each of a plurality of different excitation frequencies, the pulse repetition time being the same for each series, the flip angle
10 being different for each series.

8. A method according to Claim 6 or 7 wherein the excitation is applied as a series of excitation pulses at each of a plurality of different excitation frequencies, each series including a plurality of pulses for generating echoes, the spacing between
15 each of the plurality of pulses being different for each series.

9. A method according to any of the preceding claims wherein the excitation is applied as a series of excitation pulses at each of a plurality of different excitation frequencies and pulses at the different frequencies are applied at staggered spacings chosen
20 according to the variation of T_2^* with the environmental parameter.

10. A method according to any of the preceding claims wherein the excitation is such that the NQR response signal/noise ratio would be substantially equal at at least two differing values of the environmental parameter, and preferably it is such that that
25 ratio would be substantially constant over the range of the environmental parameter.

11. A method according to Claim 10 wherein the NQR resonance frequency of the sample varies with the given environmental parameter, and the excitation is applied at a plurality of
30 different frequencies, the number and spacing of the frequencies being such that the NQR response signal/noise ratio is substantially constant over the range of the environmental parameter.

12. A method according to Claim 11 wherein the excitation is applied at $n-1$ equally spaced frequencies, where n is the nearest integer satisfying the equation

$$n \geq \Delta\nu_0 / \Delta\nu_{\text{off}},$$

5 where $n \geq 2$, $\Delta\nu_0$ is half of the value of the resonance frequency range corresponding to the range of the environmental parameter, and $\Delta\nu_{\text{off}}$ is approximately equal to the precessional frequency.

10 13. A method according to Claim 10, 11 or 12 wherein a relaxation time of the sample varies with the given parameter, and the excitation is applied as a series of excitation pulses at a plurality of different pulse spacings and/or so as to produce a plurality of different flip angles, such that the NQR response signal/noise ratio is substantially constant over the range of
15 the environmental parameter.

14. A method according to Claim 13 wherein the NQR resonance frequency of the sample also varies with the environmental parameter, the excitation pulses are applied at a plurality of different excitation frequencies, and the pulse spacings and/or
20 flip angles associated with the excitation frequencies are such as to produce an NQR response signal of substantially equal signal/noise ratio at the respective values of the environmental parameter at which the NQR resonance frequency equals the respective excitation frequency.

25 15. A method according to any of the preceding claims wherein the excitation is applied at different frequencies to excite separate free induction decay responses.

16. A method according to any of the preceding claims wherein the excitation is applied at different frequencies to excite separate
30 echo responses.

17. A method according to Claim 15 or 16 wherein the responses occur at staggered intervals.

18. A method according to any of the preceding claims wherein the excitation includes at least one excitation pulse which is so
35 shaped as to produce a response signal whose strength is approximately constant over a limited resonance frequency range.

19. Apparatus for NQR testing a sample having at least one NQR property which varies with a given environmental parameter, comprising:-

5 storage means in which is stored information on how the or each NQR property varies over a predetermined range of the environmental parameter;

means for applying excitation to the sample to excite NQR resonance;

means for detecting the NQR response signal; and

10 means, responsive to the information stored in the storage means, for controlling the applying means to excite an NQR response signal which is detectable by the detection means over a predetermined range of the environmental parameter .

20. Apparatus according to Claim 19 wherein the storage means 15 stores information on how the NQR resonance frequency of the sample varies with temperature over a $\pm 20^{\circ}\text{C}$ temperature range, and the controlling means allows for resonance frequency shifts over such a temperature range.

21. Apparatus according to Claim 19 or 20 wherein the storage 20 means stores information on how the NQR resonance frequency of the sample varies with the given environmental parameter, and the controlling means is arranged to apply the excitation at a plurality of different excitation frequencies so that a detectable NQR resonance response signal can be excited over the 25 range of resonance frequency corresponding to the range of the environmental parameter.

22. Apparatus according to any of Claims 19 to 21 wherein the storage means stores information on how a relaxation time of the sample varies with the given parameter, and the controlling means 30 is arranged to apply the excitation as a series of excitation pulses at a plurality of different pulse spacings and/or so as to produce a plurality of different flip angles, so that a detectable NQR response signal can be excited over the range of relaxation time corresponding to the range of the environmental 35 parameter.

23. Apparatus according to any of Claims 19 to 22 wherein the control means is arranged to apply the excitation such that the NQR response signal/noise ratio would be substantially equal at at least two differing values of the environmental parameter, and preferably such that that ratio would be substantially constant over the range of the environmental parameter.

24. A method of NQR testing for the presence of selected nuclei in a sample, comprising:

deriving an NQR response signal from the sample in such a way that the signal/noise ratio would be substantially equal at at least two differing values of a given environmental parameter; and

producing an alarm signal from the NQR response signal in dependence on whether a predetermined threshold of detection has been exceeded.

25. A method according to Claim 24 wherein the nuclei have a NQR resonance frequency and/or relaxation time (T_1 , T_2 , T_{2e} , T_2^*) which vary substantially with variation of the environmental parameter, and the at least two differing values are values at which the resonance frequency and/or relaxation time are different.

26. Apparatus for NQR testing for the presence of selected nuclei in a sample, comprising:-

means for deriving an NQR response signal from the sample in such a way that the signal/noise ratio would be substantially equal at at least two differing values of a given environmental parameter; and

means for producing an alarm signal from the NQR response signal in dependence on whether a predetermined threshold of detection has been exceeded.

27. A method according to any of Claims 1 to 18, for determining the spatial distribution of temperature within a sample, wherein a relaxation time (T_1 , T_2 , T_{2e} , T_2^*), preferably spin-lattice relaxation time, T_1 , varies with temperature, and such spatial distribution is determined according to the variation of the relaxation time within the sample.

28. A method for detecting the presence within a larger article of a specific substance containing quadrupolar atomic nuclei, wherein the irradiation can allow for resonance frequency shifts caused by $\pm 20^{\circ}\text{C}$ temperature variations.

5 29. A method according to Claim 28 wherein the irradiation can allow for the resonance frequency shifts by its frequency being modulated or varied.

30. A method for detecting the presence within a larger article of a specific substance containing quadrupolar atomic nuclei,
10 wherein the power spectrum of the irradiation pulses provides substantial power within about 0.1% of any frequency to which NQR resonance may be shifted by any environmental conditions likely to apply to the article.

31. A method of NQR testing a sample substantially as herein
15 described with reference to the accompanying drawings.

32. Apparatus for NQR testing a sample substantially as herein described with reference to the accompanying drawings.

Patents Act 1977
Examiner's report to the Comptroller under
Section 17 (The Search Report)

27

Application number

9204872.7

Relevant Technical fields

- (i) UK Cl (Edition K) G1N (PART G)
- (ii) Int Cl (Edition 5) G01N G01R G01V (3/14, 3/175)

Search Examiner

D C GRACE

Databases (see over)

- (i) UK Patent Office
- (ii) ONLINE DATABASES: WPI, INSPEC

Date of Search

10 AUGUST 1992

Documents considered relevant following a search in respect of claims

24, 25, 26

Category (see over)	Identity of document and relevant passages	Relevant to claim(s)
A	GB 2200462 A (NRDC) Whole document	24, 26



Category	Identity of document and relevant passages	Relevant to claim(s)

Categories of documents

X: Document indicating lack of novelty or of inventive step.

Y: Document indicating lack of inventive step if combined with one or more other documents of the same category.

A: Document indicating technological background and/or state of the art.

P: Document published on or after the declared priority date but before the filing date of the present application.

E: Patent document published on or after, but with priority date earlier than, the filing date of the present application.

&: Member of the same patent family, corresponding document.

Databases: The UK Patent Office database comprises classified collections of GB, EP, WO and US patent specifications as outlined periodically in the Official Journal (Patents). The on-line databases considered for search are also listed periodically in the Official Journal (Patents).

Examiner's report to the Comptroller under
Section 17 (The Search Report)

Application number

9204872.7

Relevant Technical fields

- (i) UK CI (Edition K) G1N (PART G)
- (ii) Int CL (Edition 5) G01N G01R G01V (3/14,3/175)

Search Examiner

D C GRACE

Databases (see over)

- (i) UK Patent Office
- (ii) ONLINE DATABASES: WPI, INSPEC

Date of Search

15 JULY 1992

Documents considered relevant following a search in respect of claims

1-23, 27-32

Category (see over)	Identity of document and relevant passages	Relevant to claim(s)
X	GB 1329776 (IGVATOV) eg page 5 lines 1-9	1,2,4,5, 15,16,28, 29,30
X	GB 1329647 (VARIAN) whole document	1,2,4,5, 15,16,28, 29,30
X	US 4063150 (OHTE) eg column 2 lines 38-55	1,2,4,5, 15,16,27, 28,29,30
X	Journal of Magnetic Resonance, Vol 91 (1991), pages 630-36 - eg page 634, second complete paragraph	1,2,3,6, 28

Category	Identity of document and relevant passages	Relevant to claim(s)

Categories of documents

X: Document indicating lack of novelty or of inventive step.

Y: Document indicating lack of inventive step if combined with one or more other documents of the same category.

A: Document indicating technological background and/or state of the art.

P: Document published on or after the declared priority date but before the filing date of the present application.

E: Patent document published on or after, but with priority date earlier than, the filing date of the present application.

&: Member of the same patent family, corresponding document.

Databases: The UK Patent Office database comprises classified collections of GB, EP, WO and US patent specifications as outlined periodically in the Official Journal (Patents). The on-line databases considered for search are also listed periodically in the Official Journal (Patents).