



(12) **EUROPEAN PATENT APPLICATION**

(43) Date of publication:
08.06.2016 Bulletin 2016/23

(51) Int Cl.:
B61L 15/00 (2006.01) **B61L 25/04 (2006.01)**
B61L 3/12 (2006.01) **B61L 23/00 (2006.01)**
B61L 23/04 (2006.01) **B61L 25/02 (2006.01)**

(21) Application number: **14380039.9**

(22) Date of filing: **19.12.2014**

(84) Designated Contracting States:
AL AT BE BG CH CY CZ DE DK EE ES FI FR GB GR HR HU IE IS IT LI LT LU LV MC MK MT NL NO PL PT RO RS SE SI SK SM TR
 Designated Extension States:
BA ME

(71) Applicant: **Siemens Rail Automation S.A.U. ES-28760 Tres Cantos (Madrid) (ES)**

(72) Inventor: **Melchor Terleira Irazabal, Carlos E-28028 Madrid (ES)**

(30) Priority: **05.12.2014 EP 14290371**

(74) Representative: **Maier, Daniel Oliver Siemens AG Postfach 22 16 34 80506 München (DE)**

(54) **Communication method and system for exchanging information between guided vehicles**

(57) The present invention concerns an RFID system and a communication method for exchanging information between guided vehicles, the method comprising automatically exchanging information between a first guided vehicle (A) and a second guided vehicle (B), wherein each of said first guided vehicle (A) and second guided

vehicle (B) comprises an RFID system including an RFID reader (12), an RFID tag (13), and an Information Collector Module (11), hereafter called "ICM", characterized in that an RFID technique is used for exchanging said information when the first guided vehicle (A) and the second guided vehicle (B) cross each other.

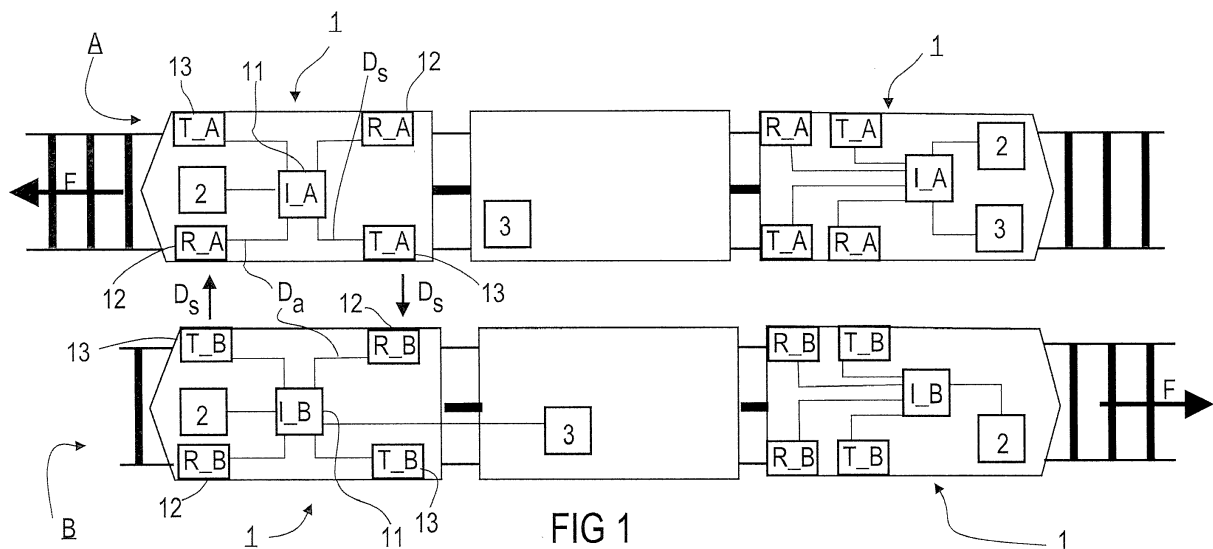

Description

[0001] The present invention concerns a system and a method of communication for the exchange of information between a first guided vehicle and a second guided vehicle.

[0002] The present invention is essentially related to the communication and information exchange between guided vehicles, wherein "guided vehicle" refers to public transport means such as buses, trolleybuses, streetcars, subways, trains or train subunits, etc., as well as load transporting means such as, for example, freight trains, for which safety is a very important factor and which are guided along a route or railway by at least one rail, in particular by two rails.

[0003] Usually, the communication and transmission of information between a first guided vehicle and a second guided vehicle takes place either

- by means of a first communication from the guided vehicle to the ground, i.e. to wayside devices capable of communicating with said first guided vehicle, and a second communication from the wayside device to the second guided vehicle generally via a control center; or
- by means of a Global System for Mobile communications-Railways (GSM-R) or a Communications-Based Train Control (CBTC) radio, each allowing the guided vehicle driver to communicate with the control center in order to provide or receive information about the second guided vehicle.

[0004] In both cases, the communication "guided vehicle to guided vehicle" involves complex devices and/or actions directly performed by the guided vehicle driver.

[0005] An objective of the present invention is to propose a system and a method of communication between guided vehicles that is simple, cheap, automatic, and in particular free of any intervention of a guided vehicle driver.

[0006] For achieving said objective, the present invention proposes to use Radio-Frequency Identification (RFID) techniques and systems for the communication between guided vehicles.

[0007] Indeed, the present invention concerns an RFID system configured for being installed on-board a guided vehicle in order to allow the latter to automatically exchange information with another guided vehicle comprising also said RFID system, the RFID system according to the invention comprising an Information Collector Module (hereafter ICM), an RFID reader and an RFID tag. The present invention also concerns a method of communication for automatically exchanging information between a guided vehicle and another guided vehicle characterized in that an RFID technique is used for automatically exchanging said information when said guided vehicle and said another guided vehicle cross each other.

[0008] In order to help for the comprehension of the

present invention and also for simplification purpose, the guided vehicle will be called the "first guided vehicle", said another guided vehicle will be called the "second guided vehicle"; the RFID system configured for equipping the first guided vehicle will be called "the RFID system C_A", the RFID system configured for equipping the second guided vehicle will be called "the RFID system C_B"; the RFID reader, RFID tag and ICM of the RFID system C_A and respectively C_B will be called respectively, the RFID reader R_A, RFID tag T_A, ICM I_A, and RFID reader R_B, RFID tag T_B, ICM I_B. In the present description, when an ICM, RFID tag, RFID reader, or RFID system is not specified by respectively I_A or I_B, T_A or T_B, R_A or R_B, C_A or C_B, it means that it can be anyone of them and/or both of them. For example, "the RFID tag may comprise a memory" means "the RFID tag T_A and/or the RFID tag T_B may comprise a memory".

[0009] The present invention concerns thus an RFID system C_A configured for being installed in a first guided vehicle in order to allow the latter to automatically exchange information with a second guided vehicle comprising an RFID system C_B that is for example identical to the RFID system C_A, the RFID system C_A comprising:

- an RFID reader R_A and an RFID tag T_A, wherein the RFID reader R_A and the RFID tag T_A are configured for being installed/mounted on the first guided vehicle in a place/location allowing the RFID tag T_A and the RFID reader R_A to communicate with respectively the RFID reader R_B and the RFID tag T_B of the RFID system C_B installed/mounted on the second guided vehicle, the exchange of information taking place in particular only when said first guided vehicle and said second guided vehicle cross each other, i.e. when the RFID reader and RFID tag of the respective guided vehicles are close enough for interacting with each other. For example the RFID reader R_A and the RFID tag T_A of the RFID system C_A according to the invention might be mounted/installed on a side of the first guided vehicle in order to allow an automatic communication and exchange of information with an RFID reader R_B and an RFID Tag T_B installed on a side of the second guided vehicle when said guided vehicles are crossing each other, for example because they are running in opposite direction or because they are passing one another, said side being directly adjacent to the RFID reader R_A and RFID tag T_A;
- an ICM I_A configured for being mounted/installed on-board the first guided vehicle, wherein the ICM I_A is

o configured for being connected to at least one on-board device of the first guided vehicle for collecting/acquiring data from said on-board device and/or transmitting data to said on-board

device and/or to another on-board device of said first guided vehicle;

o connected to the RFID reader R_A for getting additional data that might be acquired by the RFID reader R_A when reading the RFID tag T_B, said additional data being notably data selected by the ICM I_B of the RFID system C_B, and transmitted to the ICM I_A through the communication of the RFID reader R_A with the RFID tag T_B;

o connected to the RFID tag T_A for providing the latter with the selected data, said selected data being in particular data selected by the ICM I_A from said collected/acquired data, for instance after analyzing the collected/acquired data by means of the ICM I_A and designed for being transmitted to the RFID reader R_B when the latter reads the RFID tag T_A. The selected data are thus the data selected by the ICM I_A for being transmitted by means of the RFID tag T_A to the RFID reader R_B when the first and second guided vehicles cross each other. Once the RFID reader R_B receives said selected data, it transmits said selected data as "additional data" to the ICM I_B.

[0010] Preferentially, said place/location wherein the RFID tag and RFID reader are installed/mounted is a side of the guided vehicle. In particular, the RFID tag and RFID reader are installed/mounted on each side of the guided vehicle that might face a side of another guided vehicle when said guided vehicle and said another guided vehicle cross each other. In particular, the distance separating an RFID tag T_A, respectively an RFID reader R_A, and the running surface of the first guided vehicle is identical to the distance separating an RFID reader R_B, respectively an RFID tag T_B, and the running surface of the second guided vehicle in order to improve the exchange of information between the RFID systems equipping the guided vehicles, the running surface being the plane defined by the contact "rail - guided vehicle wheels".

[0011] The present invention concerns thus a method of communication for automatically exchanging information between a first guided vehicle and a second guided vehicle, wherein RFID systems as previously described and equipping each of said first and second guided vehicles automatically exchange information between said first guided vehicle and said second guided vehicle when they cross each other. In particular, the method according to the invention comprises the following steps for transmitting information from the first guided vehicle to the second guided vehicle:

- using the ICM I_A for collecting/acquiring data from an on-board device mounted/installed on-board said first guided vehicle;
- determining, by means of the ICM I_A and from the

collected/acquired data, a set of data to be transmitted by means of an RFID tag T_A connected to the ICM I_A to an RFID reader R_B installed/mounted on the second guided vehicle, said set of data, called "selected data", comprising thus data selected by the ICM I_A. The selected data might be in particular determined after analysis of the collected data by the ICM I_A and/or classification of the collected/acquired data in function of their importance regarding the security of the guided vehicle network;

- using the RFID tag T_A for transmitting the selected data to the RFID reader R_B of the RFID system C_B equipping said second guided vehicle, the transmission of the selected data taking place when the first guided vehicle and the second guided vehicle cross each other. The selected data received by the RFID reader R_B from the RFID tag T_A are then preferentially transmitted by the RFID reader R_B to the ICM I_B as additional data for further processing.

[0012] In particular, the method according to the invention comprises the following steps for allowing the first guided vehicle to receive information from the second guided vehicle:

- using the RFID reader R_A of the first guided vehicle for automatically reading and acquiring additional data provided by an RFID tag T_B of the second guided vehicle, wherein the additional data are data selected by the ICM I_B equipping the RFID system C_B installed on-board said second guided vehicle and transmitted by means of the RFID tag T_B to the RFID reader R_A when the first guided vehicle and the second guided vehicle cross each other;
- transmitting the additional data to the ICM I_A equipping the RFID system C_A of the first guided vehicle;
- optionally analyzing the additional data by means of said ICM I_A;
- triggering an action in function of the additional data, for example transmitting data to an on-board device of the first guided vehicle, the transmitted data being said additional data and/or new data determined in function of the received additional data.

[0013] The method according to the invention proposes thus a wireless use of electromagnetic fields, i.e. the RFID technique, for automatically transferring selected data between the first guided vehicle and the second guided vehicle, and vice versa, said transfer of selected data between the guided vehicles taking place and being possible only when said guided vehicles cross each other. The method steps described from the point of view of the first guided vehicle apply mutatis mutandis when described from the point of view of the second guided vehicle.

[0014] Finally, the present invention is also directed to a guided vehicle comprising the previously described

RFID system, and to a communication system between guided vehicles wherein said communication system comprises several RFID systems, each configured for equipping one guided vehicle. Of course, a single guided vehicle may comprise one or several RFID systems according to the invention, wherein each of said system is for example dedicated to the exchange of specific information or has a function of redundancy.

[0015] Further aspects of the present invention will be better understood through the following drawings, wherein like numerals are used for like and corresponding parts:

Figure 1 schematic representation of a top view of two guided vehicles crossing each other and exchanging information according to the invention.

Figure 2 schematic representation of a side view of a guided vehicle comprising two RFID systems according to the invention.

[0016] Figure 1 shows a preferred embodiment of the communication method and RFID system according to the invention. A first guided vehicle A comprising several cars or guided vehicle units is shown crossing a second guided vehicle B comprising also several cars or guided vehicle units. Each of said first and second guided vehicles A, B is equipped with an RFID system 1 according to the invention. In this preferred embodiment, the guided vehicles A, B are running in opposite direction as illustrated by the arrows F. Of course, they can also cross each other when running in a same direction if their speed is different. Each guided vehicle A, B comprises at least one RFID system 1 according the invention, but may also comprise several or redundant RFID systems according to the invention. For instance, the first guided vehicle A comprises at least one RFID system C_A for example a first RFID system equipping the first car of the first guided vehicle A, and a second RFID system equipping the last car of the first guided vehicle A. Similarly, the second guided vehicle B may comprise at least one RFID system C_B, for instance a first RFID system installed in the first car and a second RFID system installed in the last car of the second guided vehicle B. In this case, the cars situated between the first car and the last car of each guided vehicle are for example free of any RFID system according to the invention.

[0017] Each RFID system 1 according to the invention comprises:

- an RFID reader 12, for example the RFID reader R_A for the RFID system of the first guided vehicle A and the RFID reader R_B for the second guided vehicle B;
- an RFID tag 13, for example the RFID tag T_A for the first guided vehicle A and the RFID tag T_B for the second guided vehicle B;
- an ICM 11 to which the RFID reader 12 and RFID

tag 13 are connected, for example, the ICM I_A for the first guided vehicle and the ICM I_B for the second guided vehicle.

[0018] In particular, each RFID system of the first guided vehicle A comprises at least one RFID reader R_A 12 and at least one RFID tag T_A 13 configured for being installed on a side of the first guided vehicle A. Preferentially, it comprises two RFID readers R_A and two RFID tags T_A, so that each side of the first guided vehicle A that may face a side of the second guided vehicle B might be equipped with at least one RFID reader R_A and at least one RFID tag T_A. Similarly, each RFID system of the second guided vehicle B comprises at least one RFID reader R_B 12 and at least one RFID tag T_B 13 configured for being installed on a side of the first guided vehicle A. Preferentially, it comprises two RFID readers R_B and two RFID tags T_B, so that each side of the second guided vehicle B that may face a side of the first guided vehicle A might be equipped with at least one RFID reader R_B and at least one RFID tag T_B.

[0019] The ICM 11, for example the ICM I_A of the first guided vehicle A, or the ICM I_B of the second guided vehicle B, is configured for being connected to at least one on-board device, said on-board device being for example a control system 2 or a sensor 3 of the guided vehicle it equips, or another ICM 11 installed on-board the same guided vehicle, for example in another car of the guided vehicle. The connection of the IMC to the on-board device might be a wire or wireless communication, the IMC being in particular capable of wirelessly communicating with said on-board device. The sensor 3 might be a speed sensor, or an environmental sensor (weather conditions), or a proximity sensor (for detecting obstacles on the track). In particular, the ICM 11 is configured for collecting/acquiring data from said on-board device. For example, the ICM collected/acquired data might be at least one of the following: the guided vehicle ID, its speed, detected obstacles on the track, guided vehicle delay compared to a schedule, any change of a configuration of the guided vehicle, environmental conditions, alerts, emergency issues, adhesion factor, etc.

[0020] The ICM 11 according to the invention is for example an FPGA. Preferentially, the ICM 11 according to the invention comprises a processor and a memory for analyzing said collected/acquired data and determining at least one set of data, wherein the data composing said set of data are called the "selected data" Ds and are the data transmitted by the ICM to the RFID tag of the RFID system of the guided vehicle for being communicated by said RFID tag to the RFID reader of the RFID system of another guided vehicle. Preferentially, the ICM I_A may determine another set of data, wherein the data composing said another set of data are called the "written data" and are data transmitted by the ICM I_A to the RFID reader R_A for being written by said RFID reader R_A on a memory of the RFID tag T_B of the RFID system of the second guided vehicle B. Finally, the ICM 11 equip-

ping an RFID system of a guided vehicle is in particular also configured for receiving additional data D_a from the RFID reader equipping the RFID system of said guided vehicle, wherein said additional data D_a are the data read by the RFID reader when reading a RFID tag of an RFID system equipping another guided vehicle. The selected data D_s might be all data collected by the ICM 11, or part of said data collected by the ICM 11, or new data calculated/determined from at least one of said collected data. The written data might be for example data that have to be communicated to a guided vehicle running on the same track as the guided vehicle whose RFID system created said written data. Advantageously, the RFID system equipping a first guided vehicle A running on a first track might thus use the RFID system installed in a second guided vehicle B running on second track adjacent to said first track for storing the written data and then providing said written data by means of the RFID system installed in said second guided vehicle B to subsequent guided vehicles running on said first track. By this way, the written data might be used for providing information related to a specific track to the guided vehicles running on said specific track, wherein the RFID system of a guided vehicle running on a track adjacent to the specific track is used as a "mobile transporter" of the written data, i.e. of relevant information for said specific track. In particular, for example in addition, the selected data transmitted by the RFID tag T_A to the ICM I_B by means of the reading of said RFID tag T_A by the RFID reader R_B might be configured for triggering a reconfiguration of the RFID tag T_B by means of the ICM I_B so that the RFID tag T_B transmits said selected data previously received to guided vehicles running on said first track, i.e. on the same track as the track of the guided vehicle whose RFID system transmitted the additional data. In other words, the ICM I_B of the RFID system C_B might be able to configure the RFID tag T_B in function of the additional data, i.e. in function of the selected data received by the RFID reader R_B , said selected data comprising instruction for triggering said configuration of the RFID tag T_B so that the latter transmits at least part of the previously received selected data to each next guided vehicle it crosses.

[0021] For example, the selected data D_s collected/acquired by the ICM I_A are then transmitted by said ICM I_A to the RFID tag T_A in order to be stored in the RFID tag T_A and thus available for a reading by the RFID reader R_B . The RFID tag 13 according to the invention might be active or passive. It comprises in particular a memory for storing the selected data D_s and making them available for a reading by an RFID reader 12. The RFID tag 13 might be configured for automatically storing each selected data it receives, or optionally the ICM might be able to store the selected data in the memory of the RFID tag 13 and/or to read said memory. The ICM 11 and/or the RFID tag 13 are configured for managing the memory of the RFID tag 13, in particular for managing the selected data stored in the RFID tag memory. The RFID tag ac-

ording to the invention might be a "read-only" RFID tag (wherein the RFID reader can only read the selected data stored in the RFID tag) or a "read/write" RFID tag (wherein the RFID reader can read the selected data stored in the RFID tag, and if necessary write some other data in the memory of the RFID tag, i.e. the so-called written data). Read-only and read/write RFID tags are well known by the skilled man and do not need further explanations.

[0022] Preferentially, each RFID system 1 according to the invention comprises at least two RFID tags 13 and two RFID readers 12, wherein at least one RFID tag 13 and one RFID reader 11 are configured for being installed/mounted on one side of the guided vehicle, for example on one side of the first car of the guided vehicle, and at least one other RFID tag 13 and one other RFID reader 12 are configured for being installed/mounted on another side of said guided vehicle, so that both sides (in principle lateral sides, i.e. each side of the guided vehicle that faces a side of another guided vehicle when the guided vehicles cross each other) of the guided vehicle are equipped with at least one RFID reader 12 and at least one RFID tag 13 as illustrated in Figure 1.

[0023] According to the present invention, the first guided vehicle A and the second guided vehicle B preferentially exchange their respective selected data D_s stored in the memory of their respective RFID tags of their respective RFID systems when they cross each other, i.e. when the RFID tag T_A and the RFID reader R_B face each other so that the RFID reader R_B might read the selected data D_s from, and/or write the so-called written data on, the memory of the RFID tag T_A . For this purpose, each RFID tag T_A , T_B installed on the first, respectively second, guided vehicle and each RFID reader R_B , R_A installed on the second, respectively first, guided vehicle are placed on the respective guided vehicles so that they may interact with each other when the first and second guided vehicles cross each other.

[0024] For example, when the first guided vehicle A and the second guided vehicle B cross each other, the RFID reader R_A equipping the first guided vehicle A may read and/or write the memory of the RFID tag T_B equipping the second guided vehicle B. The read data are the selected data D_s transmitted by the ICM I_B to the RFID tag R_B equipping the second guided vehicle B and that are then read by the RFID reader R_A of the first guided vehicle A and transmitted by said RFID reader R_A to the ICM I_A as additional data D_a . The so-called written data are data written by the RFID reader R_A on the memory of the RFID tag T_B , and that can be then read by other RFID readers that communicate with the RFID tag T_B whose memory comprises said written data.

[0025] Each RFID reader 12 equipping an RFID system according to the invention installed on a first guided vehicle A is configured for reading an RFID tag (i.e. for receiving radio signal from the RFID tag) equipping an RFID system installed on a second guided vehicle B

when the first guided vehicle A crosses the second guided vehicle B. When reading the RFID tag, selected data and/or written data if any are collected by the RFID reader. The data collected by the RFID reader are transmitted by the latter to the ICM as additional data. Said additional data may trigger an action performed by the ICM. The latter is in particular able to analyze said additional data and to determine the actions to be performed. Examples of actions are sending an alert to the guided vehicle driver, sending data to an on-board device to which the ICM is connected, for example a control system or another ICM, displaying information in the cabin of the guided vehicle driver, etc. In particular, the additional data might automatically trigger said action.

[0026] To summarize, the present invention proposes a simple system and method of communication between guided vehicle based on the exchange of data (selected data/written data) by means of RFID techniques, wherein the data are instantaneously transferred from one RFID system to another RFID system equipping different guided vehicles when said guided vehicles cross each other and are close enough for allowing the communication between an RFID tag and an RFID reader. The RFID systems according to the invention form a new kind of communication system for guided vehicles.

Claims

1. RFID system (1) configured for being installed on-board a first guided vehicle (A) in order to allow the latter to automatically exchange information with a second guided vehicle (B), the RFID system (1) according to the invention comprising:
 - an RFID reader (12) configured for being installed in a location on the first guided vehicle A that allows said RFID reader (12) to read an RFID tag (13) of an RFID system installed on-board the second guided vehicle when the first guided vehicle (A) and the second guided vehicle (B) cross each other;
 - an RFID tag (13) configured for being installed in a location on the first guided vehicle (A) that allows said RFID tag (13) to be read by an RFID reader (12) of the RFID system installed on-board the second guided vehicle (B) when the first guided vehicle (A) and the second guided vehicle (B) cross each other;
 - an Information Collector Module (11), hereafter called "ICM", wherein said ICM (11) is configured for being connected to an on-board device (2, 3) of the first guided vehicle (A) for acquiring/transmitting data from/to said on-board device (2, 3), said ICM (11) being connected to the RFID reader (12) for getting additional data (Da) wherein the additional data (Da) are data acquired by the RFID reader (12) when reading

the RFID tag (13) of the RFID system equipping the second guided vehicle, said ICM (11) being furthermore connected to the RFID tag (13) for providing the latter with selected data (Ds) that are data selected from the data acquired from the on-board device (2,3) and designed for being read by the RFID reader (12) of the RFID system of the second guided vehicle (B).

2. RFID system (1) according to claim 1, wherein the RFID tag (13) comprises a memory and the ICM (11) is capable to write the selected data (Ds) on said memory and/or read said memory.
3. RFID system (1) according to claim 1 or 2, wherein the ICM (11) comprises a memory and a processor.
4. RFID system (1) according to one of the claims 1-3, wherein the ICM (11) is configured for triggering an action when receiving the additional data Da.
5. RFID system (1) according to claim 4, wherein said action is one of the following actions: sending an alert to the guided vehicle driver; sending data to an on-board device (2, 3) to which the ICM (11) is connected; displaying information in a cabin of the first guided vehicle (A).
6. RFID system (1) according to one of the claims 1 to 5, wherein the RFID reader (12) is configured for writing data on a memory of the RFID tag (13) of the RFID system configured for equipping the second guided vehicle (B).
7. First guided vehicle (A) comprising the RFID system (1) according to one of the claims 1 to 6 for exchanging information with a second guided vehicle (B) when they cross each other.
8. Communication method for automatically exchanging information between a first guided vehicle (A) and a second guided vehicle (B), wherein each of said first guided vehicle (A) and second guided vehicle (B) comprises an RFID system including an RFID reader (12), an RFID tag (13), and an Information Collector Module (11), hereafter called "ICM", **characterized in that** an RFID technique is used for exchanging said information when the first guided vehicle (A) and the second guided vehicle (B) cross each other.
9. Communication method according to claim 8, wherein transmitting information from the first guided vehicle (A) to the second guided vehicle (B) comprises:
 - using the ICM (11) installed on-board the first guided vehicle (A) for acquiring data from an on-board device installed on-board said first guided

- vehicle (A);
- determining from the acquired data a set of data, hereafter called the "selected data", to be transmitted by means of the RFID tag (13) of the RFID system (1) equipping the first guided vehicle (A) to the RFID reader (12) of the RFID system of the second guided vehicle (B);
 - using the RFID tag (13) of the RFID system (1) equipping the first guided vehicle (A) for transmitting the selected data to the RFID reader (12) of the RFID system equipping the second guided vehicle (B), the transmission of the selected data taking place when the first guided vehicle (A) and the second guided vehicle (B) cross each other.
10. Communication method according to claim 8 or 9, wherein the first guided vehicle (A) acquires information from the second guided vehicle (B) according to the following steps:
- using the RFID reader (12) installed on-board the first guided vehicle (A) for automatically reading and acquiring additional data (Da) by reading the RFID tag (13) of the RFID system equipping the second guided vehicle (B);
 - transmitting the additional data (Da) to the ICM (11) of the RFID system equipping the first guided vehicle (A) ;
 - triggering an action in function of the additional data (Da) by means of the ICM (11).
11. Communication method according to claim 10, wherein triggering an action comprising one of the followings actions: sending an alert to the guided vehicle driver; sending data to an on-board device (2, 3) to which the ICM (11) is connected; displaying information in a cabin of the first guided vehicle (A).
12. Communication method according to claim 10 or 11 wherein the additional data (Da) are data selected by the ICM (11) equipping the RFID system installed on-board the second guided vehicle (B) and transmitted by means of the RFID tag (13) installed on the second guided vehicle (B) to the RFID reader (12) installed on the first guided vehicle (A) when the first guided vehicle (A) and the second guided vehicle (B) cross each other.
13. Communication method according to one of the claims 10 to 12 wherein the ICM (11) triggers said action after analysis of the additional data (Da).
14. Communication method according to one of the claims 8-11 comprising using the RFID reader (12) of the RFID system installed on-board the first guided vehicle (A) for writing data, hereafter called "written data", on a memory of the RFID tag (13) of the RFID system installed on-board the second guided vehicle (B).
15. Communication method according to claim 13 wherein the written data are data specific to the track on which the first guided vehicle (A) is running.

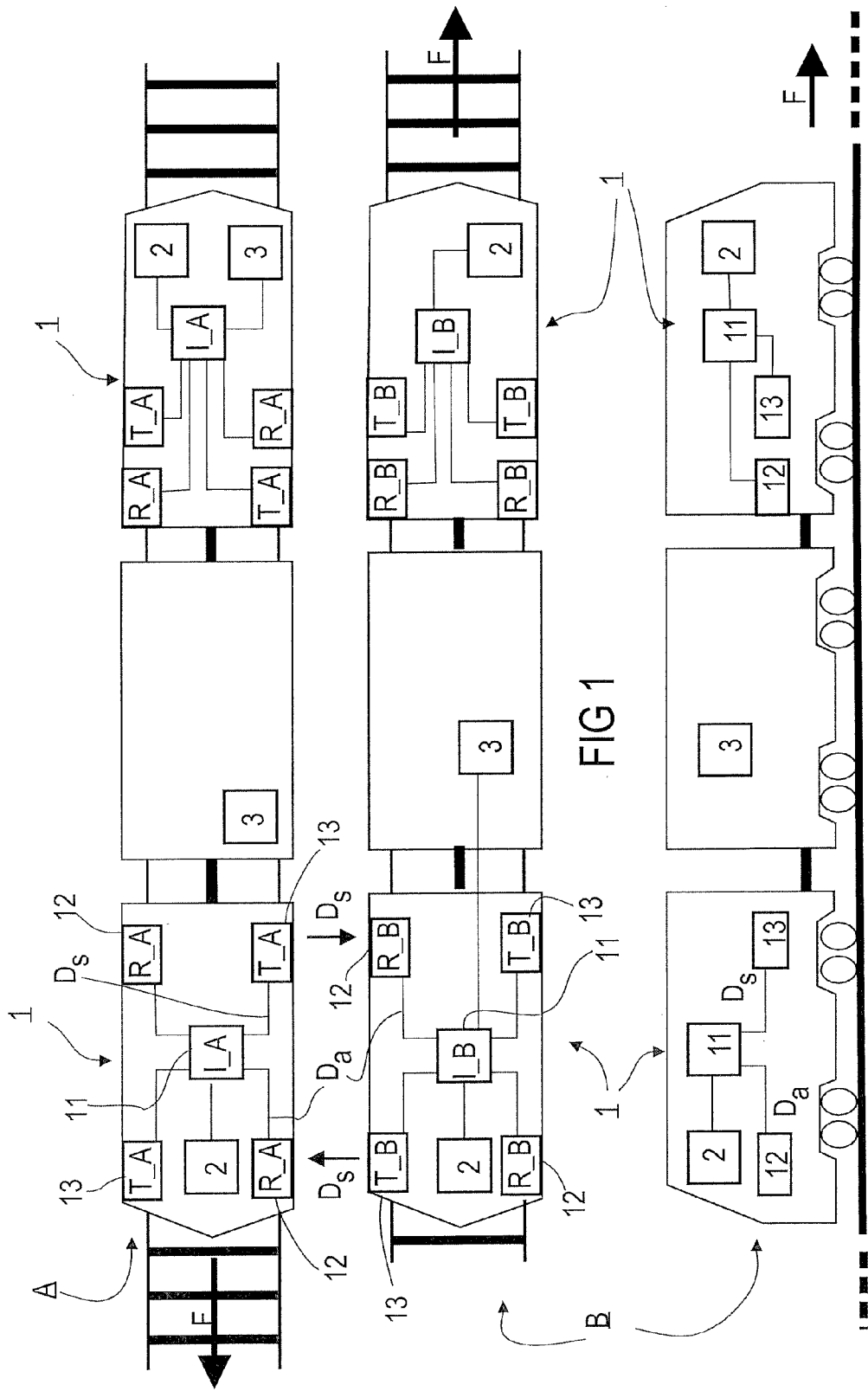

FIG 1

FIG 2



EUROPEAN SEARCH REPORT

Application Number
EP 14 38 0039

5

10

15

20

25

30

35

40

45

50

55

DOCUMENTS CONSIDERED TO BE RELEVANT			
Category	Citation of document with indication, where appropriate, of relevant passages	Relevant to claim	CLASSIFICATION OF THE APPLICATION (IPC)
X	US 2005/088320 A1 (KOVACH ARAM [US]) 28 April 2005 (2005-04-28)	1-14	INV. B61L15/00 B61L25/04
Y	* paragraph [0020] - paragraph [0021] * * paragraph [0027] - paragraph [0029] * * paragraph [0046] - paragraph [0048] * * figure 1 *	15	ADD. B61L3/12 B61L23/00 B61L23/04 B61L25/02
X	WO 2011/129800 A1 (ZLOJUTRO MILAN [US]) 20 October 2011 (2011-10-20) * paragraph [0018] * * paragraph [0025] * * figure 3 *	1-14	
Y	EP 2 572 955 A1 (SIEMENS SAS [FR]; SIEMENS AG [DE]) 27 March 2013 (2013-03-27) * paragraph [0038] - paragraph [0041] *	15	
			TECHNICAL FIELDS SEARCHED (IPC)
			B61L
The present search report has been drawn up for all claims			
Place of search Munich		Date of completion of the search 26 January 2016	Examiner Janhsen, Axel
CATEGORY OF CITED DOCUMENTS X : particularly relevant if taken alone Y : particularly relevant if combined with another document of the same category A : technological background O : non-written disclosure P : intermediate document		T : theory or principle underlying the invention E : earlier patent document, but published on, or after the filing date D : document cited in the application L : document cited for other reasons & : member of the same patent family, corresponding document	

1
EPO FORM 1503 03 82 (P04C01)

**ANNEX TO THE EUROPEAN SEARCH REPORT
ON EUROPEAN PATENT APPLICATION NO.**

EP 14 38 0039

5 This annex lists the patent family members relating to the patent documents cited in the above-mentioned European search report.
The members are as contained in the European Patent Office EDP file on
The European Patent Office is in no way liable for these particulars which are merely given for the purpose of information.

26-01-2016

Patent document cited in search report	Publication date	Patent family member(s)	Publication date
US 2005088320 A1	28-04-2005	NONE	
-----	-----	-----	-----
WO 2011129800 A1	20-10-2011	CN 103201778 A	10-07-2013
		US 2013033386 A1	07-02-2013
		WO 2011129800 A1	20-10-2011
-----	-----	-----	-----
EP 2572955 A1	27-03-2013	NONE	
-----	-----	-----	-----

EPO FORM P0459

For more details about this annex : see Official Journal of the European Patent Office, No. 12/82