

(No Model.)

H. MILLER.
FLY BRUSH.

No. 451,290.

Patented Apr. 28, 1891.

Fig: 1.

Fig: 2.

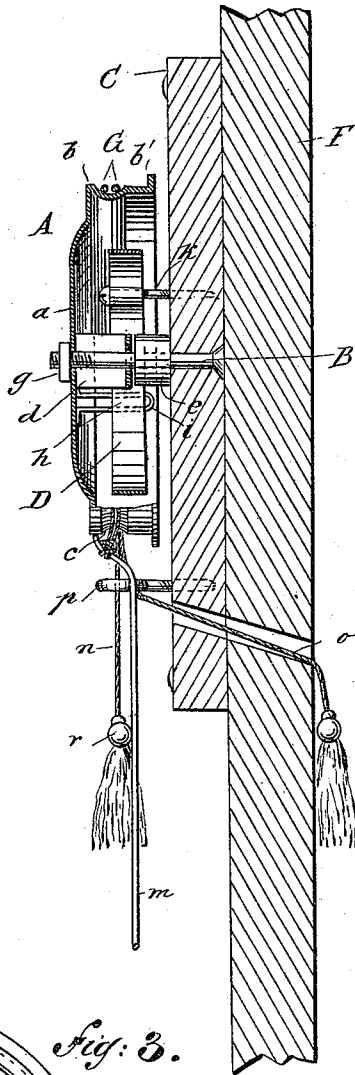
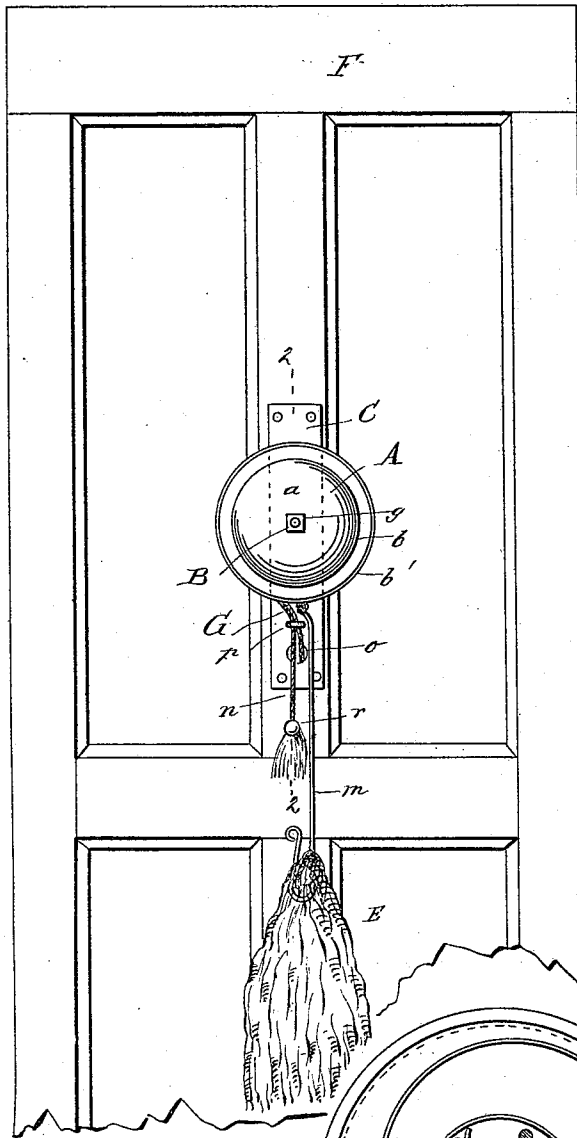
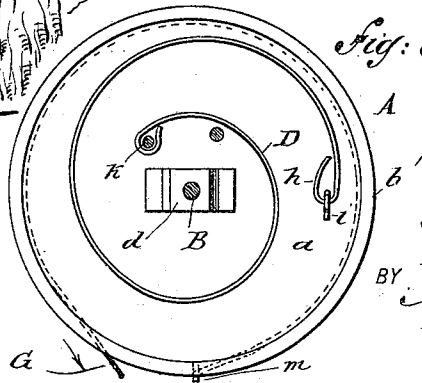

Fig: 3.



WITNESSES:
Chas. Nida.
C. Sedgwick

INVENTOR:
H. Miller
BY *Munn & Co*
ATTORNEYS

UNITED STATES PATENT OFFICE.

HARVEY MILLER, OF WATERLOO, IOWA.

FLY-BRUSH.

SPECIFICATION forming part of Letters Patent No. 451,290, dated April 28, 1891.

Application filed February 16, 1891. Serial No. 381,586. (No model.)

To all whom it may concern:

Be it known that I, HARVEY MILLER, of Waterloo, in the county of Black Hawk and State of Iowa, have invented a new and useful Improvement in Fly-Brushes, of which the following is a full, clear, and exact description.

The object of this invention is to provide a fly-brushing attachment for a door, which may be easily operated from either side of the door to drive flies from its exterior previous to opening said door, so as to prevent their entrance within the house.

To this end my invention consists in certain features of construction and combination of parts, as is hereinafter described and claimed.

Reference is to be had to the accompanying drawings, forming a portion of this specification, in which similar letters of reference indicate corresponding parts in all the views.

Figure 1 shows the improvement in position for use upon the exterior of a door broken away below. Fig. 2 is a sectional side elevation of the device on the line 2 2 in Fig. 1; and Fig. 3 is a rear face view of the device detached, showing interior parts.

The improved fly-brush is designed to be located upon the exterior surface of a house-door, and by its manipulation be caused to alternately revolve in opposite directions, swinging the brush proper across the surface of the door and its casement, so as to drive away the flies that usually lodge upon the door ready to enter the house when the door is opened.

The cylindrical spring-case A of the device is composed of a circular dished plate *a* and a circular rim *b*, projecting laterally from the edge of said plate, its free edge being stiffened by a short radial flange *b'*. The outer surface of the rim *b* is grooved, as represented in Fig. 2 at *c*.

A central perforation is formed in the plate *a* of the spring-case A to receive a supporting-bolt B, whereon the case is designed to be revolved. A bracket-frame *d* is centrally attached to and projects inwardly from the plate *a*, and is apertured for the passage of the bolt B, thereby forming an additional bearing for the casing.

A base board or plate C is provided for the fly-brush mechanism, which is supported revo-

lably therefrom by the bolt B, which extends from the base-plate, having a collar *e* slipped upon its body and located between the base-plate and the bracket-frame *d*, the outer end of the bolt which projects through the plate *a* being engaged by a nut *g*, that serves to secure the spring-case A in place upon the bolt, free to turn on it in either direction.

Within the spring-case A the volute spring D is seated, having one of its ends *h* looped fast to staple *i* or other equivalent projection from the plate *a*, the outer end of the spring having a looped engagement with the stud *k*, which is inserted in the adjacent base-plate C.

The fly-brush E is secured upon the outer terminal end of the swing-bar *m*, which has its opposite end attached to the spring-case firmly. A sufficient length should be given to the swing-bar *m* to allow the fly-brush E to sweep across the major portion of the door F, whereon the base-plate C is secured at a proper point, motion being communicated to the brush in the following manner:

A cord G, of proper strength and length, is provided, which is doubled and secured at its center of length to the swing-bar *m* near the juncture of the latter with the spring-case A. The doubled portions of the cord G are extended around the spring-case A, resting in the groove *c* of the rim *b*, one end *n* of the cord hanging pendent, as shown in Figs. 1 and 2, and the other end *o* extending through a transverse aperture formed in the base-plate C and door F, so as to allow a portion of this end of the cord to hang pendent within the room, against the inner surface of the door.

Both of the end portions *no* of the cord G are passed through the ring of a screw-eye bolt *p*, which is projected from the base-plate C near to the spring-case A and directly below the center bolt B, thus affording a guide for the cord ends, and from its location also serving as an abutment for the swing-bar *m* to rest against. The ends of the cord G are furnished with weighted pull knobs or tassels *r*, that keep the cord stretched and prevent its displacement.

When the device is to be used, the pull-knob on the side of the door approached by the operator is grasped and pulled the full

downward draft of the cord end, revolving the spring-case so as to cause the fly-brush to make a complete revolution in one direction, the force of the spring returning the case and brush to its normal position.

The operation may be repeated as frequently as is desired or is necessary to remove the flies which may be swarming upon the outer surface of the door, and as the pendent cord ends are on opposite sides of the door the device can be operated with equal facility from without or inside of the room having its outer door furnished with the improvement.

Having thus described my invention, I claim as new and desire to secure by Letters Patent—

1. The combination, with a base-plate which may be secured upon the exterior of a house door, of a revolubly-supported spring-case, a fly-brush thereon, and a pull-cord wrapped upon the exterior of the case, substantially as set forth.

2. The combination, with a base-plate secured on the exterior of a door, of a case, a

supporting-bolt therefor, a volute spring secured by one end to the case and the other end to the base-plate, a swing-bar projected from the case, a fly-brush on the outer end of the swing-bar, and a pull-cord secured to and wrapped on the case and having a pendent portion that will rotate the case when it is pulled, substantially as set forth.

3. The combination, with a house-door and a base-plate secured thereon, both having aligning perforations, of a case, a supporting-bolt central therein, a volute spring secured by one end to the case and the other end to the base-plate, a swing-bar radially projected from the case, a fly-brush on the swing-bar, an abutment-post having an eye on its outer end, and a doubled cord secured at its bight to the swing-bar and wrapped once around the case, having one end pendent, and the other end inserted through a hole in the base-plate and door, substantially as set forth.

HARVEY MILLER.

Witnesses:

W. C. LOGAN,

E. L. JOHNSON.