



INTERNATIONAL APPLICATION PUBLISHED UNDER THE PATENT COOPERATION TREATY (PCT)

<p>(51) International Patent Classification ⁶ : C09K 13/00, 13/06, 13/08</p>	<p>A1</p>	<p>(11) International Publication Number: WO 99/46353 (43) International Publication Date: 16 September 1999 (16.09.99)</p>
---	-----------	--

<p>(21) International Application Number: PCT/US99/03615 (22) International Filing Date: 18 February 1999 (18.02.99) (30) Priority Data: 09/037,586 9 March 1998 (09.03.98) US (71) Applicant: ONTRAK SYSTEMS, INC. [US/US]; 1010 Rincon Circle, San Jose, CA 95131 (US). (72) Inventors: LI, Xu; Apartment #9, 1901 Halford Avenue, Santa Clara, CA 95051 (US). ZHAO, Yuexing; 1043 Ridge Mont Drive, Milpitas, CA 95035 (US). HYMES, Diane, J.; 887 Lewiston Drive, San Jose, CA 95136 (US). DELARIOS, John, M.; 941 Loma Verde, Palo Alto, CA 94303 (US). (74) Agents: MALLIE, Michael, J. et al.; Blakely, Sokoloff, Taylor & Zafman LLP, 7th floor, 12400 Wilshire Boulevard, Los Angeles, CA 90025 (US).</p>	<p>(81) Designated States: AL, AM, AT, AT (Utility model), AU (Petty patent), AZ, BA, BB, BG, BR, BY, CA, CH, CN, CU, CZ, CZ (Utility model), DE, DE (Utility model), DK, DK (Utility model), EE, EE (Utility model), ES, FI, FI (Utility model), GB, GD, GE, GH, GM, HR, HU, ID, IL, IN, IS, JP, KE, KG, KP, KR, KZ, LC, LK, LR, LS, LT, LU, LV, MD, MG, MK, MN, MW, MX, NO, NZ, PL, PT, RO, RU, SD, SE, SG, SI, SK, SK (Utility model), SL, TJ, TM, TR, TT, UA, UG, UZ, VN, YU, ZW, ARIPO patent (GH, GM, KE, LS, MW, SD, SZ, UG, ZW), Eurasian patent (AM, AZ, BY, KG, KZ, MD, RU, TJ, TM), European patent (AT, BE, CH, CY, DE, DK, ES, FI, FR, GB, GR, IE, IT, LU, MC, NL, PT, SE), OAPI patent (BF, BJ, CF, CG, CI, CM, GA, GN, GW, ML, MR, NE, SN, TD, TG).</p> <p>Published <i>With international search report.</i></p>
--	---

(54) Title: METHODS AND APPARATUS FOR CLEANING SEMICONDUCTOR SUBSTRATES AFTER POLISHING OF COPPER FILM

(57) Abstract

A cleaning solution, method, and apparatus for cleaning semiconductor substrates after chemical mechanical polishing of copper films is described. The present invention includes a cleaning solution which combines deionized water, an organic compound, and an ammonium compound in an acidic pH environment for cleaning the surface of a semiconductor substrate after polishing a copper layer. Such methods of cleaning semiconductor substrates after copper CMP alleviate the problems associated with brush loading and surface and subsurface contamination. The figure illustrates a flowchart of one embodiment of the process of the present invention wherein (310) is the step of polishing a copper layer on a semiconductor substrate followed by (320) the step of placing the polished semiconductor substrate in a scrubber followed by (330) the step of scrubbing the polished semiconductor substrate and ending with (340) the step of applying an acidic cleaning solution to the polished semiconductor substrate during scrubbing.

```

    graph TD
      310[POLISHING A COPPER LAYER ON A SEMICONDUCTOR SUBSTRATE] --> 320[PLACING THE POLISHED SEMICONDUCTOR SUBSTRATE IN A SCRUBBER]
      320 --> 330[SCRUBBING THE POLISHED SEMICONDUCTOR SUBSTRATE]
      330 --> 340[APPLYING AN ACIDIC CLEANING SOLUTION TO THE POLISHED SEMICONDUCTOR SUBSTRATE DURING SCRUBBING]
    
```

FOR THE PURPOSES OF INFORMATION ONLY

Codes used to identify States party to the PCT on the front pages of pamphlets publishing international applications under the PCT.

AL	Albania	ES	Spain	LS	Lesotho	SI	Slovenia
AM	Armenia	FI	Finland	LT	Lithuania	SK	Slovakia
AT	Austria	FR	France	LU	Luxembourg	SN	Senegal
AU	Australia	GA	Gabon	LV	Latvia	SZ	Swaziland
AZ	Azerbaijan	GB	United Kingdom	MC	Monaco	TD	Chad
BA	Bosnia and Herzegovina	GE	Georgia	MD	Republic of Moldova	TG	Togo
BB	Barbados	GH	Ghana	MG	Madagascar	TJ	Tajikistan
BE	Belgium	GN	Guinea	MK	The former Yugoslav Republic of Macedonia	TM	Turkmenistan
BF	Burkina Faso	GR	Greece	ML	Mali	TR	Turkey
BG	Bulgaria	HU	Hungary	MN	Mongolia	TT	Trinidad and Tobago
BJ	Benin	IE	Ireland	MR	Mauritania	UA	Ukraine
BR	Brazil	IL	Israel	MW	Malawi	UG	Uganda
BY	Belarus	IS	Iceland	MX	Mexico	US	United States of America
CA	Canada	IT	Italy	NE	Niger	UZ	Uzbekistan
CF	Central African Republic	JP	Japan	NL	Netherlands	VN	Viet Nam
CG	Congo	KE	Kenya	NO	Norway	YU	Yugoslavia
CH	Switzerland	KG	Kyrgyzstan	NZ	New Zealand	ZW	Zimbabwe
CI	Côte d'Ivoire	KP	Democratic People's Republic of Korea	PL	Poland		
CM	Cameroon	KR	Republic of Korea	PT	Portugal		
CN	China	KZ	Kazakstan	RO	Romania		
CU	Cuba	LC	Saint Lucia	RU	Russian Federation		
CZ	Czech Republic	LI	Liechtenstein	SD	Sudan		
DE	Germany	LK	Sri Lanka	SE	Sweden		
DK	Denmark	LR	Liberia	SG	Singapore		
EE	Estonia						

METHODS AND APPARATUS FOR CLEANING SEMICONDUCTOR SUBSTRATES
AFTER POLISHING OF COPPER FILM

This application is a continuation-in-part of U.S. Patent Application Serial No. 08/955,393, entitled "Methods and Apparatus for Cleaning Semiconductor Substrates after Polishing of Copper Film", filed October 21, 1997.

BACKGROUND OF THE INVENTION

1. Field of the Invention

This invention relates to methods and apparatus for processing and cleaning a substrate, and more specifically to methods and apparatus for cleaning semiconductor substrates after polishing of copper films.

2. Background Information

In the manufacture of advanced semiconductor devices, copper (Cu) is beginning to replace aluminum (Al) as the material for metallization. Cu has become desirable due to its lower resistivity and significantly improved electromigration lifetime, when compared to Al.

One process for Cu metallization uses a dual damascene approach. As illustrated in Figure 1a, a dielectric layer 110 is deposited above a substrate 100. Dielectric layer 120 may be made up of materials such as silicon dioxide. Vias and/or trenches 120 are then formed in the dielectric layer 110, as illustrated in Figure 1b. Vias/trenches 120 may be formed, for example, using dry etching techniques. Next, a thin layer of barrier material (barrier layer) 130, for example, tantalum (Ta), titanium (Ti), or titanium nitride (TiN) is deposited as illustrated in Figure 1c. After barrier layer 130 is deposited the vias/trenches 120 are filled with copper (Cu) layer 140, as illustrated in Figure 1d. Cu layer 140 may be deposited using well known deposition techniques, for example, chemical vapor deposition (CVD), physical vapor deposition (PVD), or electroplating. In order to isolate the copper interconnects, as illustrated in Figure 1e, the excess copper layer 140 and barrier layer 130 must be removed.

-2-

One method for removing the excess copper layer 140 and barrier layer 130 is polishing the surface of the substrate, for example, polishing using chemical mechanical polishing (CMP). In a CMP process, the semiconductor substrate is polished with a slurry containing abrasive particles, such as alumina particles, and an oxidant, such as hydrogen peroxide. In the CMP process, contaminants are introduced which include particles and/or metal contamination on the copper layer 150, dielectric surface 160, and in the dielectric subsurface 165.

Regardless of how the CMP process is performed, the surface of semiconductor substrate must be cleaned of contaminants. If not removed, these contaminants may affect device performance characteristics and may cause device failure to occur at faster rates than usual. Cleaning the semiconductor substrate after chemical mechanical polishing of copper may be necessary to remove such contaminants from the copper layer and dielectric layers.

One method for cleaning the semiconductor substrate after polishing of the copper layer is brush scrubbing. Brush scrubbing, whether single-sided or double-sided brush scrubbing, is the industry standard for cleaning oxide and tungsten CMP applications. However, there are several problems associated with applying brush scrubbing to post copper CMP cleaning.

One such problem is brush loading. During the CMP process, the top surface of the copper layer may be oxidized and forms copper oxide, for example copper oxide (Cu_2O or CuO) or copper hydroxide ($\text{Cu}(\text{OH})_2$). In basic or neutral pH cleaning environments, the copper oxide or copper hydroxide does not dissolve and may be transferred to the brushes, thus loading the brushes. The contaminated (or loaded) brushes may then transfer the copper oxide or copper hydroxide contaminants to subsequently processed substrates during cleaning.

For tungsten and other oxide applications, brush loading could be curtailed by adding a dilute ammonium hydroxide (NH_4OH). In the presence of NH_4OH , part of the copper oxide may form $\text{Cu}(\text{NH}_3)_2^+$ complex and may be dissolved; however, due to the high pH environment, the dilute ammonium

-3-

hydroxide has been found to be insufficient to prevent brush loading of copper oxide. Additionally, it has been found that scrubbing with dilute ammonium hydroxide also causes etching of the copper layer and may cause serious surface roughening.

Brush loading may also occur when alumina particles are used in the copper CMP process. In neutral or inorganic acid (e.g., HCl) cleaning environments, there is an electrostatic attraction between alumina particles and the silicon dioxide surface which makes it difficult to remove the alumina particles from the surface of the dielectric material. Because of the electrostatic attractive force, the alumina particles may also adhere to the brush and cause another brush loading problem with similar effects to those discussed above.

Yet another problem caused by the CMP process is that the surface and subsurface of the dielectric layer may become contaminated during polishing with metal from the copper layer and barrier layer as well as other contaminants from the slurry. During the CMP process, contaminants, especially metal contaminants, may penetrate into the dielectric layer up to approximately 100 angstroms (Å) from the surface. Again, these contaminants may affect device performance characteristics and may cause device failure.

SUMMARY OF THE INVENTION

A cleaning solution, methods and apparatus for cleaning semiconductor substrates after chemical mechanical polishing of copper films is described. In one embodiment, the surface of a semiconductor substrate is cleaned after a copper layer has been polished using a cleaning solution which includes deionized water, an organic compound, and an ammonium compound to create an acidic pH environment.

Additional features and benefits of the present invention will become apparent from the detailed description, figures, and claims set forth below.

BRIEF DESCRIPTION OF THE DRAWINGS

The present invention will be understood more fully from the detailed description given below and from the accompanying drawings of various

-4-

embodiments of the invention, which, however, should not be taken to limit the invention to the specific embodiments, but are for explanation and understanding only.

Figure 1a illustrates a semiconductor substrate having a dielectric layer deposited thereon.

Figure 1b illustrates the semiconductor substrate of Figure 1a after vias and/or trenches are formed in the dielectric layer.

Figure 1c illustrates the semiconductor substrate of Figure 1b after a thin barrier layer has been deposited thereon.

Figure 1d illustrates the semiconductor substrate of Figure 1c after a layer of Copper material has been deposited thereon.

Figure 1e illustrates the semiconductor substrate of Figure 1d after chemical mechanical polishing of the excess copper layer and barrier layer.

Figure 2 illustrates one embodiment of a scrubber system.

Figure 3 illustrates a flowchart of one embodiment of the process of the present invention.

DETAILED DESCRIPTION

Methods and apparatus for cleaning semiconductor substrates after polishing of copper film are disclosed. In the following description, numerous specific details are set forth such as specific materials, processes, parameters, dimensions, etc. in order to provide a thorough understanding of the present invention. It will be apparent, however, to one skilled in the art that these specific details need not be employed to practice the present invention. In other instances, well known materials or methods have not been described in detail in order to avoid obscuring the present invention.

The following description describes cleaning solutions, methods, and apparatus for cleaning a semiconductor substrate. In one embodiment, the cleaning of a semiconductor wafer occurs after the formation of copper interconnect(s) and chemical mechanical polishing (CMP)/planarization of that copper interconnect(s). Processes for formation of copper interconnects in

-5-

semiconductor device fabrication are well known in the art and are therefore not described in detail herein.

It should also be noted that the term "semiconductor substrate" used herein refers to a silicon semiconductor substrate or a part thereof, such as gallium arsenide, upon which device layers have been or are going to be formed. It should also be noted that the term substrate includes but is not limited to fully processed, semi-processed, or unprocessed substrates with semiconductor materials thereon.

Additionally, although the cleaning solutions, methods and apparatus for cleaning are described in conjunction with the scrubbing of a semiconductor substrate or wafer, it will be appreciated that any similarly shaped, i.e. generally flat substrate, may be processed by the methods and apparatus of the present invention. Further, it will be appreciated that reference to a semiconductor substrate or wafer may include a bare or pure semiconductor substrate, with or without doping, a semiconductor substrate with epitaxial layers, a semiconductor substrate incorporating one or more device layers at any stage of processing, other types of substrates incorporating one or more semiconductor layers such as substrates having semiconductor on insulator (SIO) devices, or substrates for processing other apparatus and devices such as flat panel displays, multichip modules, etc.

In one embodiment, a cleaning solution used to clean semiconductor substrates is made up of deionized water, an organic compound, and an inorganic compound, all of which are combined, creating an acidic pH environment for cleaning the surface of a semiconductor substrate. Again, such cleaning may occur after polishing a copper layer. The use of an acidic pH environment helps dissolve copper oxide and alleviates some of the problems of brush loading discussed in the background of the invention. It is advantageous to keep the acidic pH environment within a pH level range of approximately 1-6. In one embodiment, the acidic pH environment has a pH level in the range of approximately 2-4.

The use of an organic compound (e.g., an organic acid) helps to form metallic complex compounds, thereby helping removal of the metal

-6-

contamination from the surface of the dielectric layer and from the surface of the brush. Some examples of organic acids that may be used include: citric acid, malic acid, malonic acid, succinic acid, or any combination of such organic acids.

In one embodiment, the organic compound is dissolved in deionized water (DIW) in a concentration range of approximately 100ppm to 2% by weight. In alternate embodiments, a more preferred concentration range may be approximately 200ppm to 0.1% by weight. In one embodiment, when citric acid is the organic compound, concentration of the citric acid dissolved in deionized water is approximately 0.2% by weight.

The use of an inorganic compound helps to change the electrostatic forces between the particles and surfaces of the brush and substrate in order to make them repulsive. Thus, the particles repel the brushes and the substrate and the substrate and brushes repel the particles, providing favorable conditions for particle removal. In one embodiment, the inorganic compound in the cleaning solution may be ammonium hydroxide (NH_4OH), the ammonium salt of an inorganic acid (e.g., ammonium chloride (NH_4Cl), ammonium fluoride (NH_4F)), or an anionic surfactant.

It is desirable to dissolve the inorganic compound in deionized water (DIW) in a concentration range of approximately 100ppm to 2% by weight. In one embodiment, where the inorganic compound is an ammonium compound, the ammonium compound is dissolved in DIW such that the concentration range is approximately 200ppm to 0.1% by weight. In one embodiment, the concentration of ammonium hydroxide (when used in the cleaning solution) when dissolved in DIW is approximately 0.02% by weight.

One example of the many different ways in formulating the cleaning solution is: 0.02% NH_4OH , 0.2% Citric Acid by weight mixed in DIW. The pH level of the solution in this example is approximately 4.

If an ammonium salt, such as for example, ammonium chloride or ammonium fluoride, is used, the concentration range of the ammonium salt dissolved in DIW may be approximately 0.05% - 0.1% by weight. Also, if an

-7-

anionic surfactant is used, the concentration range of the anionic surfactant dissolved in DIW may be approximately 50ppm to 0.2% by weight.

In one embodiment, a cleaning solution of DIW, ammonium salt and a chloride compound is used to clean the semiconductor substrates. In one embodiment, the pH level of the solution is in the range of approximately 2-4. The ammonium salt may be one of the ammonium salts discussed above. In one embodiment, it is desirable to dissolve the ammonium salt in deionized water (DIW) in a concentration range of approximately 200ppm to 0.2% by weight. In one embodiment, the ammonium salt is dissolved in the DIW in a concentration of approximately 0.1% by weight. The chloride compound may comprise hydrochloric acid (HCL), ammonium chloride, or a combination of the two. In one embodiment, it is desirable to dissolve the chloride compound in DIW in a concentration range of approximately 0.1% to 1% by weight. In one embodiment, the chloride compound is dissolved in DIW in a range of approximately 0.1% by weight.

The cleaning solution may comprise a mixture of chemicals in DIW containing an organic acid, ammonium salt of an inorganic acid, or an anionic surfactant in an acidic pH environment. In such a case, the organic acid may be one of those organic acids listed above, and with a concentration, when dissolved in DIW, of approximately 0.2% by weight or in a concentration range of 0.1% to 1% by weight. In the case of using an anionic surfactant, it is desirable to dissolve the anionic surfactant in DIW in a concentration range of approximately 50ppm to 0.2% by weight and approximately 0.2% by weight in one embodiment.

In one embodiment, the chemicals of the present invention are pre-mixed in the same cleaning solution to simultaneously solve several problems related to post copper CMP cleaning using a brush scrubber. Cross contamination from substrate to substrate and within the same substrate are therefore reduced substantially, or even prevented in this simple approach. Hydrochloric acid (HCl) may also be added to the solution to adjust pH and help dissolve copper oxide.

-8-

The present invention covers various formulations of the cleaning solution, and that each component in the solution may be replaced by different chemical that has similar properties. As described in the background of the invention, after the copper interconnects on a semiconductor substrate have been planarized using CMP techniques, it is necessary to clean the semiconductor substrate and remove any contaminants from the surface and subsurface of the semiconductor substrate. One such technique for removing contaminants from the semiconductor substrate is scrubbing the semiconductor substrate (substrate).

As an example, and not by limitation, the present invention is described in conjunction with a scrubbing process, more specifically, a scrubbing process in which both sides of the wafer are scrubbed simultaneously. The scrubber may include a number of stations. Each of these stations represents one or more steps in the substrate cleaning process. Contaminated substrates are loaded at one end of the system and cleaned and dried substrates are unloaded from the other end of the system. Example of a systems of this type are the DSS-200TM Scrubber and the SynergyTM Scrubber available from OnTrak Systems, Inc. of Milpitas, California.

Figure 2 represents a cross sectional view of a SynergyTM configuration (cleaning system). Usually, the contaminated substrates are delivered to the cleaning system after chemical mechanical planarization (CMP) from a wet bench or from other processes resulting in contamination. At the start of the cleaning process contaminated substrates are loaded into a wafer cassette 280 (cassette) and the cassette 280 is then placed into the wet send indexer station 210. After cassette 280 is placed into wet send indexer station 210, the substrates are automatically removed from the cassette 280 and placed, one at a time, into the outside brush station 220.

In the outside brush station 220, a substrate is processed through a first scrub. During the first scrub, the cleaning solution may be applied to the substrate in several different ways. For example, in one embodiment the cleaning solution is sprayed onto the substrate. In another embodiment the cleaning solution is applied to the substrate through brushes 221. Yet another

embodiment applies the cleaning solution by dripping the cleaning solution onto the substrate.

The scrubbed substrate is then automatically removed from the outside brush station 220 and placed into the inside brush station 230. In the inside brush station 230, the substrate is processed through a second scrub. In the inside brush station 230 the cleaning solution may be applied to the substrate in a similar manner as in outside brush station 220.

After the second scrub the substrate is then automatically removed from the inside brush station 230 and placed into the rinse, spin and dry station 240. Rinse, spin, and dry station 240 rinses, spins, and dries the substrate. At this point the wafer has been cleaned.

Once the rinse, spin, and dry steps have been completed the substrate is then transported from the rinse, spin, and dry station 240 to the output station 250 where the substrate will be placed into cassette 281. The transfer is usually carried out by a robotic arm which lifts the substrate out of the rinse, spin, and dry station 240 by its edges and places it into the cassette 281. The cassette is then transferred to storage or to another cleaning or processing system.

It will be apparent to one of ordinary skill in the art that some of the steps in the cleaning system described above may occur in another order and/or with various solutions depending upon the substrate or substrate layer being cleaned. For example, different cleaning solutions, such as water, citric acid, ammonium hydroxide, ammonium citrate, and hydrofluoric acid solution (or mixtures of solutions) may be used in one of the brush stations. Also, other systems may include one brush station, or more than two brush stations. Moreover, other systems may omit one or more of the above stations/steps and may include additional processing stations, such as a CMP station.

While the previous description illustrates a cleaning system in which both sides of the substrate are scrubbed simultaneously, the techniques described herein may be used in other cleaning systems and processes. For example, a cleaning system in which only a single side of the substrate is scrubbed or a cleaning system in which the substrate is cleaned with chemical spray.

-10-

Figure 3 illustrates one embodiment of a cleaning process. At step 310, the copper layer is planarized using chemical mechanical polishing. It should be noted that other techniques for planarization of the copper layer may be used and that it may still be desirable to clean the semiconductor substrate using the present invention after such planarization in order to remove potential contaminants from the substrate surface and/or subsurface.

At step 320, the polished semiconductor substrate is then placed in a scrubber. The substrate is then scrubbed, at step 330, to remove the contaminants caused by the polishing process. During scrubbing, a cleaning solution, such as described above, is applied to the substrate in order to aid and/or effectuate the removal of the contaminants (step 340). This cleaning solution may be used in either outside brush station 220 or inside brush station 230, or both brush stations if necessary, of the scrubber in Figure 2.

Thus, embodiments of the present invention, which may include cleaning environment and methods for cleaning substrates, such as, for instance, post copper CMP substrates, alleviate the problems of brush loading without affecting the quality of the copper and dielectric layers. Furthermore, these embodiments, when used to clean post copper CMP substrates have the capability of removing surface and subsurface contaminants from the copper and dielectric layers.

Hence, methods and apparatus for cleaning semiconductor substrates after polishing of copper film have been described. Although specific embodiments, including specific equipment, parameters, methods, and materials have been described, various modifications to the disclosed embodiments will be apparent to one of ordinary skill in the art upon reading this disclosure. Therefore, it is to be understood that such embodiments are merely illustrative of and not restrictive on the broad invention and that this invention is not limited to the specific embodiments shown and described.

CLAIMS

What is claimed is:

1. A cleaning solution for cleaning semiconductor substrates comprising a first amount of a deionized water, a second amount of an organic acid, and a third amount of an ammonium compound, all combined to create an acidic pH environment.
2. The cleaning solution as defined in claim 1 wherein the acidic pH environment is a buffered acidic pH environment.
3. The cleaning solution as defined in claim 1 wherein the acidic pH environment has a pH level in the range of approximately 1-6.
4. The cleaning solution as defined in claim 1 wherein the second amount of organic acid is dissolved in the first amount of deionized water at a concentration range of approximately 100ppm to 2% by weight.
5. The cleaning solution as defined in claim 1 wherein the second amount of organic acid is dissolved in the first amount of deionized water at a concentration range of approximately 200ppm to 0.1% by weight.
6. The cleaning solution as defined in claim 1 wherein the third amount of the ammonium compound is dissolved in the first amount at a concentration range of approximately 100ppm to 0.1% by weight.
7. The cleaning solution as defined in claim 1 wherein the second amount of organic acid is selected from the group consisting of: citric acid, malic acid, malonic acid, succinic acid, and any combination thereof.
8. The cleaning solution as defined in claim 1 wherein the third amount of the ammonium compound is selected from the group consisting of:

-12-

ammonium hydroxide (NH_4OH), ammonium chloride (NH_4Cl), ammonium fluoride (NH_4F), and any combination thereof.

9. A cleaning solution for cleaning semiconductor substrates comprising a first amount of a deionized water, a second amount of an ammonium salt of an organic acid, and a third amount of a chloride compound, all combined to create an acidic pH environment.
10. The cleaning solution as defined in claim 9 wherein the acidic pH environment is a buffered acidic pH environment.
11. The cleaning solution as defined in claim 9 wherein the acidic pH environment has a pH level in the range of approximately 2-4.
12. The cleaning solution as defined in claim 9 wherein the second amount of ammonium salt of organic acid is dissolved in the first amount of deionized water at a concentration range of approximately 200ppm to 0.2% by weight.
13. The cleaning solution as defined in claim 9 wherein the third amount of the chloride compound is dissolved in the first amount of deionized at a concentration range of approximately 0.1% to 1% by weight.
14. The cleaning solution as defined in claim 9 wherein the third amount of the chloride compound is selected from the group consisting of: hydrogen chloride, ammonium chloride, and any combination thereof.
15. A cleaning solution for cleaning semiconductor substrates comprising a first amount of a deionized water, second amount of an anionic surfactant, third amount of an organic acid, all combined to create an acidic pH environment.

-13-

16. The cleaning solution as defined in claim 15 wherein the acidic pH environment is a buffered acidic pH environment.
17. The cleaning solution as defined in claim 15 wherein the acidic pH environment has a pH level in the range of approximately 2-4.
18. The cleaning solution as defined in claim 15 wherein the second amount of anionic surfactant is dissolved in the first amount of deionized water at a concentration range of approximately 50ppm to 0.2% by weight.
19. The cleaning solution as described in claim 15 wherein the third amount of the organic compound is dissolved in the first amount of deionized water at a concentration range of approximately 0.1% to 1% by weight.
20. The cleaning solution as described in claim 15 wherein the third amount of the organic compound is selected from the group consisting of: citric acid, malic acid, malonic acid, succinic acid, and any combination thereof.
21. A method to remove contaminants from a semiconductor substrate comprising:
 - placing the semiconductor substrate having a polished copper layer in a scrubbing apparatus; and
 - scrubbing the semiconductor substrate in an acidic cleaning solution comprising deionized water, organic acid, and ammonium compound.
22. The method as defined in claim 21 wherein the acidic cleaning solution is a buffered acidic cleaning solution.
23. The method as defined in claim 21 wherein the acidic cleaning solution has a pH level in the range of approximately 1-6.

-14-

24. The method as defined in claim 21 wherein the acidic cleaning solution has a pH level in the range of approximately 2-4.
25. The method as defined in claim 21 the organic acid is dissolved in the deionized water at a concentration range of approximately 100ppm to 2% by weight.
26. The method as defined in claim 21 wherein the of organic acid is dissolved in the deionized water at a concentration range of approximately 200ppm to 0.2% by weight.
27. The method as defined in claim 21 wherein the ammonium compound is dissolved in the deionized water at a concentration range of approximately 50ppm to 0.5% by weight.
28. The method as defined in claim 21 wherein the ammonium compound is dissolved in the deionized water at a concentration range of approximately 100ppm to 0.1% by weight.
29. The method as defined in claim 22 wherein the organic acid is selected from the group consisting of: citric acid, malic acid, malonic acid, succinic acid, and any combination thereof.
30. The method as defined in claim 22 wherein the ammonium compound is selected from the group consisting of: ammonium hydroxide (NH_4OH), ammonium chloride (NH_4Cl), ammonium fluoride (NH_4F) and any combination thereof.
31. A method to remove contaminants from a semiconductor substrate comprising:
 - placing the semiconductor substrate having a polished copper layer in a scrubbing apparatus; and

-15-

scrubbing the semiconductor substrate in an acidic cleaning solution comprising deionized water, an ammonium salt of organic acid, and a chloride compound.

32. The method defined in claim 31 wherein the acidic pH environment is a buffered acidic pH environment.

33. The method defined in claim 31 wherein the acidic pH environment has a pH level in the range of approximately 2-4.

34. The method defined in claim 31 wherein the ammonium salt of organic acid is dissolved in the deionized water at a concentration range of approximately 200ppm to 0.2% by weight.

35. The method defined in claim 31 wherein the chloride compound is dissolved in the deionized at a concentration range of approximately 0.1% to 1% by weight.

36. The method defined in claim 31 wherein the chloride compound is selected from the group consisting of: hydrogen chloride, ammonium chloride, and any combination thereof.

37. A method to remove contaminants from a semiconductor substrate comprising:
placing the semiconductor substrate having a polished copper layer in a scrubbing apparatus; and
scrubbing the semiconductor substrate in an acidic cleaning solution comprising deionized water, an anionic surfactant, and an organic compound.

38. The method defined in claim 37 wherein the acidic pH environment is a buffered acidic pH environment.

-16-

39. The method defined in claim 37 wherein the acidic pH environment has a pH level in the range of approximately 2-4.
40. The method defined in claim 37 wherein the anionic surfactant is dissolved in the deionized water at a concentration range of approximately 50ppm to 0.2% by weight.
41. The method described in claim 37 wherein the organic compound is dissolved in the deionized water at a concentration range of approximately 0.1% to 1% by weight.
42. The cleaning solution as described in claim 37 the organic compound is selected from the group consisting of: citric acid, malic acid, malonic acid, succinic acid, and any combination thereof.
43. A scrubber for processing a semiconductor substrate comprising:
an input to receive a semiconductor substrate having a polished copper layer;
a brush assembly coupled to the input; and
a cleaning solution delivery system for delivering a cleaning solution comprising a deionized water, an organic acid, and an ammonium compound, wherein said cleaning solution delivery system delivers the cleaning solution premixed to create an acidic pH environment to the semiconductor substrate having a polished copper layer.
44. A scrubber for processing a semiconductor substrate comprising:
an input to receive a semiconductor substrate having a polished copper layer;
a brush assembly coupled to the input; and
a cleaning solution delivery system for delivering a cleaning solution comprising a deionized water, an ammonium salt of organic acid, and a chloride compound, wherein said cleaning solution delivery system delivers

-17-

the cleaning solution premixed to create an acidic pH environment to the semiconductor substrate having a polished copper layer.

45. A scrubber for processing a semiconductor substrate comprising:
an input to receive a semiconductor substrate having a polished copper layer;
a brush assembly coupled to the input; and
a cleaning solution delivery system for delivering a cleaning solution comprising a deionized water, an anionic surfactant, and an organic compound, wherein the cleaning solution delivery system delivers the cleaning solution premixed to create an acidic pH environment to the semiconductor substrate having a polished copper layer.

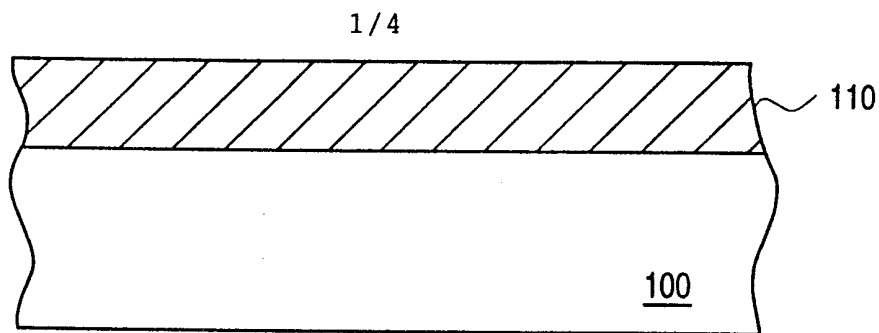

FIG. 1a

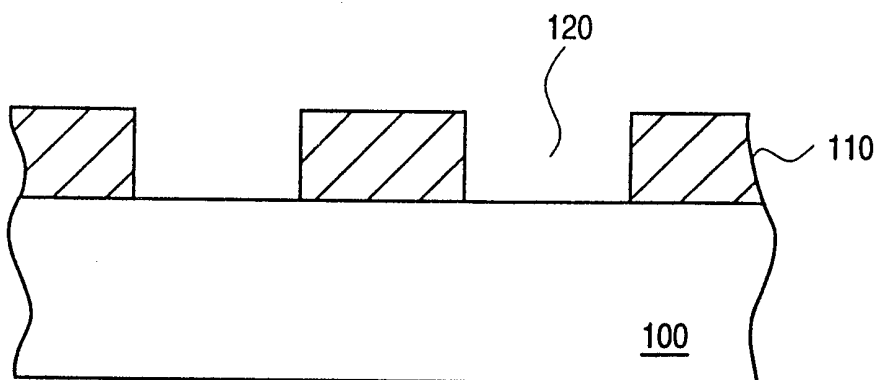

FIG. 1b

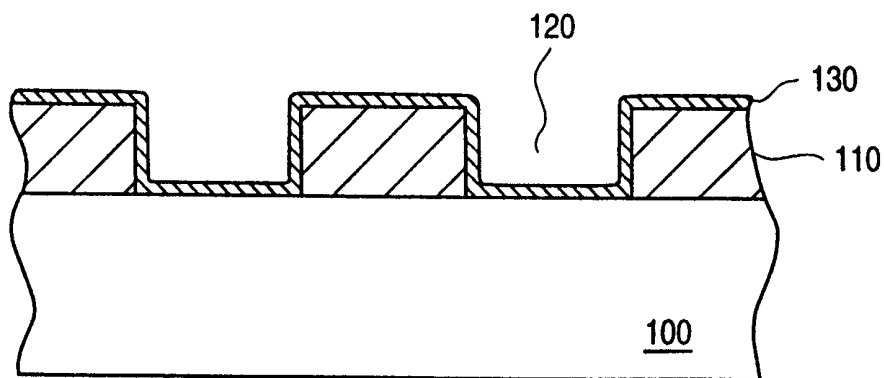

FIG. 1c

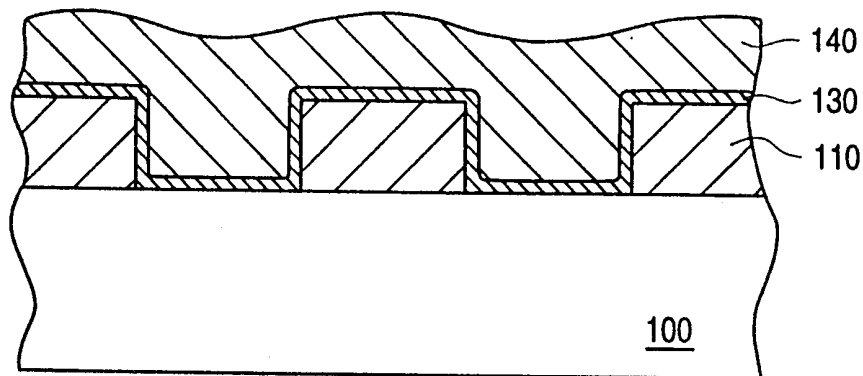

FIG. 1d

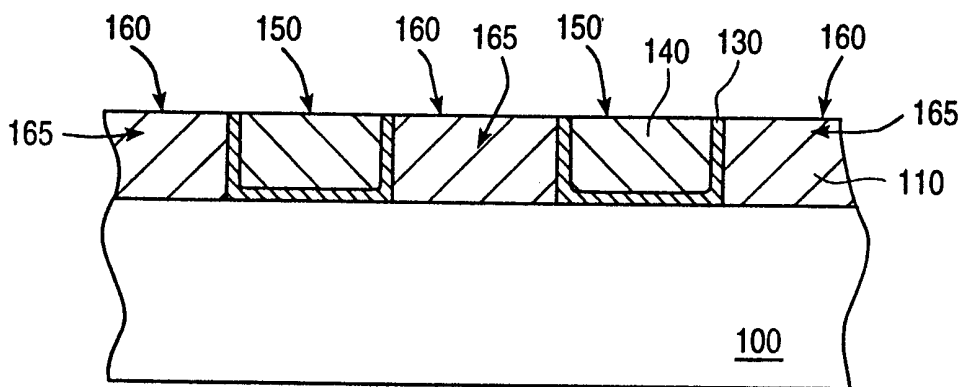

FIG. 1e

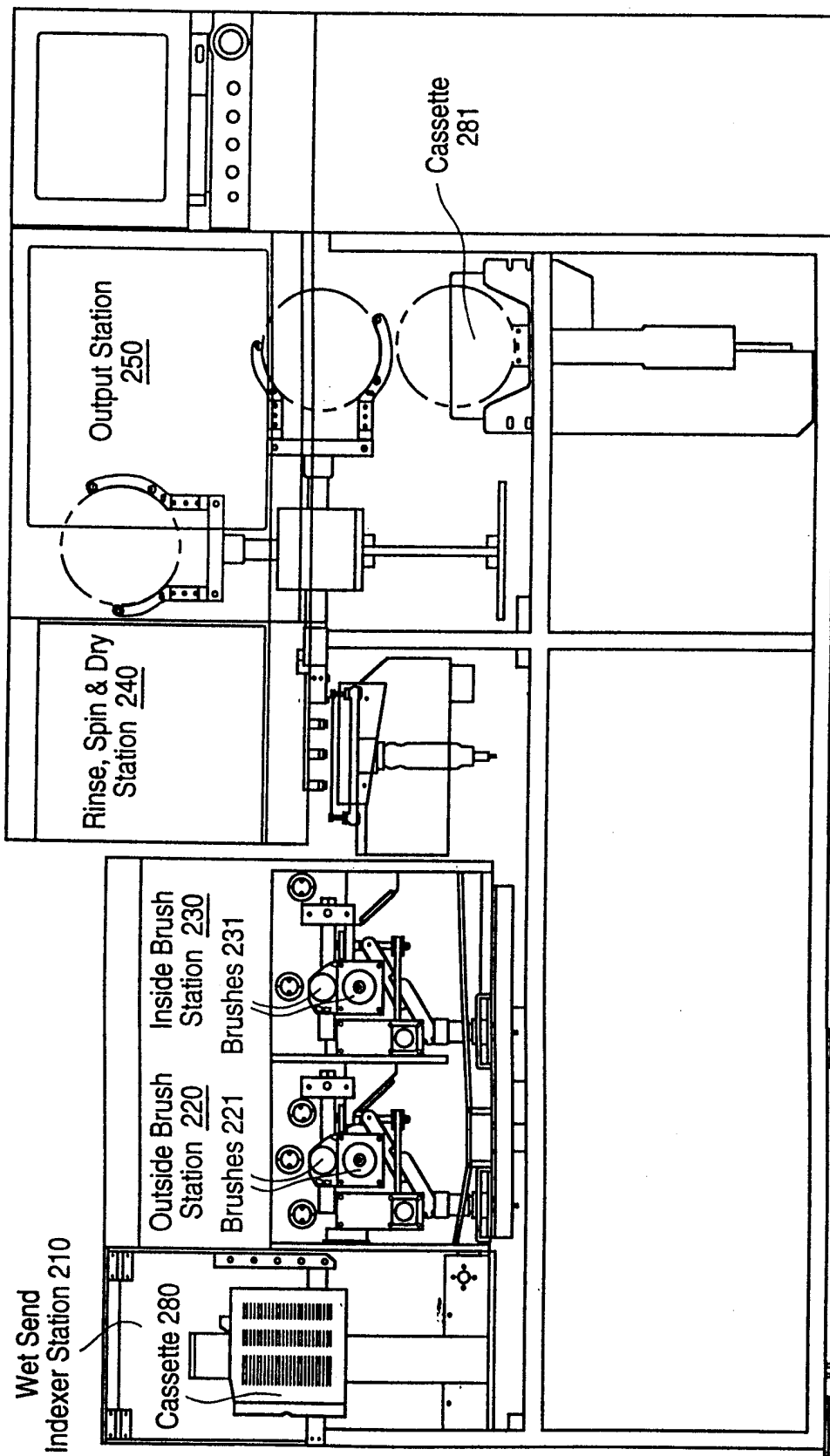

FIG. 2

4 / 4

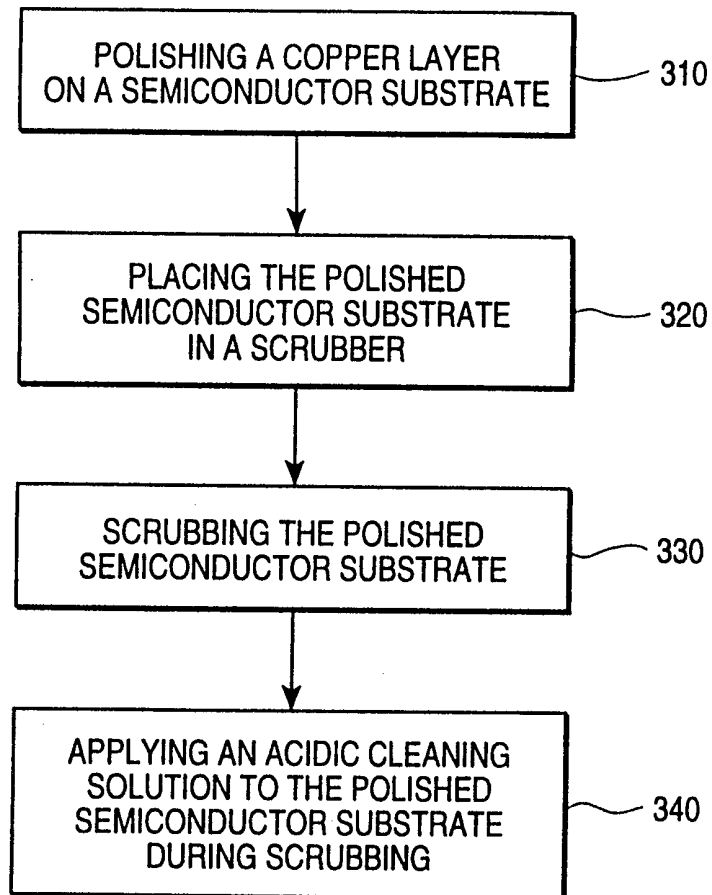

FIG. 3

INTERNATIONAL SEARCH REPORT

International application No.
PCT/US99/03615

A. CLASSIFICATION OF SUBJECT MATTER		
IPC(6) : C09K 13/00, 13/06, 13/08 US CL : 510/175, 176, 178; 134/ 2, 3 According to International Patent Classification (IPC) or to both national classification and IPC		
B. FIELDS SEARCHED		
Minimum documentation searched (classification system followed by classification symbols) U.S. : 510/175, 176, 178; 134/ 2, 3		
Documentation searched other than minimum documentation to the extent that such documents are included in the fields searched		
Electronic data base consulted during the international search (name of data base and, where practicable, search terms used) APS, WEST 1.0		
C. DOCUMENTS CONSIDERED TO BE RELEVANT		
Category*	Citation of document, with indication, where appropriate, of the relevant passages	Relevant to claim No.
X,P	US 5,806,126 A (DE LARIOS et al) 15 September 1998, col. 2, lines 58-67, col. 7, lines 1-6.	43-45
X ---- Y	US 5,662,769 A (SCHONAUER et al) 02 September 1997, col. 5, lines 10-11.	1-4, 7-8 ----- 5-6, 21-30
X	US 5,200,024 A (BLONDER et al) 06 April 1993, col. 5-6, lines 5-6.	1, 7-8
Y	US 5,714,203 A (SCHELLENBERGER et al.) 03 February 1998, col. 3, lines 55-67, col. 4, lines 9.	15-20, 37-42
Y	US 5,630,904 A (AOYAMA et al) 20 May 1997, col. 2, lines 27-39, col. 4, lines 1-4.	9-14, 31-36
<input type="checkbox"/> Further documents are listed in the continuation of Box C. <input type="checkbox"/> See patent family annex.		
* Special categories of cited documents: *A* document defining the general state of the art which is not considered to be of particular relevance *B* earlier document published on or after the international filing date *L* document which may throw doubts on priority claim(s) or which is cited to establish the publication date of another citation or other special reason (as specified) *O* document referring to an oral disclosure, use, exhibition or other means *P* document published prior to the international filing date but later than the priority date claimed		*T* later document published after the international filing date or priority date and not in conflict with the application but cited to understand the principle or theory underlying the invention *X* document of particular relevance; the claimed invention cannot be considered novel or cannot be considered to involve an inventive step when the document is taken alone *Y* document of particular relevance; the claimed invention cannot be considered to involve an inventive step when the document is combined with one or more other such documents, such combination being obvious to a person skilled in the art *G* document member of the same patent family
Date of the actual completion of the international search 10 MAY 1999		Date of mailing of the international search report 08 JUN 1999
Name and mailing address of the ISA/US Commissioner of Patents and Trademarks Box PCT Washington, D.C. 20231 Facsimile No. (703) 305-3230		Authorized officer DAWN GARRETT <i>Regina Wall</i> Telephone No. (703) 308-0661

INTERNATIONAL SEARCH REPORT

International application No.
PCT/US99/03615

Box I Observations where certain claims were found unsearchable (Continuation of item 1 of first sheet)

This international report has not been established in respect of certain claims under Article 17(2)(a) for the following reasons:

1. Claims Nos.:
because they relate to subject matter not required to be searched by this Authority, namely:

2. Claims Nos.:
because they relate to parts of the international application that do not comply with the prescribed requirements to such an extent that no meaningful international search can be carried out, specifically:

3. Claims Nos.:
because they are dependent claims and are not drafted in accordance with the second and third sentences of Rule 6.4(a).

Box II Observations where unity of invention is lacking (Continuation of item 2 of first sheet)

This International Searching Authority found multiple inventions in this international application, as follows:

Please See Extra Sheet.

1. As all required additional search fees were timely paid by the applicant, this international search report covers all searchable claims.
2. As all searchable claims could be searched without effort justifying an additional fee, this Authority did not invite payment of any additional fee.
3. As only some of the required additional search fees were timely paid by the applicant, this international search report covers only those claims for which fees were paid, specifically claims Nos.:

4. No required additional search fees were timely paid by the applicant. Consequently, this international search report is restricted to the invention first mentioned in the claims; it is covered by claims Nos.:

Remark on Protest

- The additional search fees were accompanied by the applicant's protest.
 No protest accompanied the payment of additional search fees.

INTERNATIONAL SEARCH REPORT

International application No.
PCT/US99/03615

EOX II. OBSERVATIONS WHERE UNITY OF INVENTION WAS LACKING

This ISA found multiple inventions as follows:

Group I, claim(s) 1-8, 21-30, and 43, drawn to a composition, method, and apparatus.

Group II, claim(s) 9-14, 31-36, and 44, drawn to a composition, method, and apparatus.

Group III, claim(s) 15-20, 37-42, and 45, drawn to a composition, method, and apparatus.

The inventions listed as Groups I, II, and III do not relate to a single inventive concept under PCT Rule 13.1 because, under PCT Rule 13.2, they lack the same or corresponding special technical features for the following reasons: the special technical features of the Group I invention is a particular composition including methods and an apparatus drawn to the particular composition, Group II invention is a particular composition including methods and an apparatus drawn to the particular composition, and Group III invention is a particular composition including methods and an apparatus drawn to the particular composition. Since the special technical feature of the Group I invention is not present in the Group II or Group III inventions and the special technical feature of Group II invention is not present in Group III invention being claimed, unity of invention is lacking.