

F. H. GILSON & F. E. REED.  
PAPER FOLDING MACHINE.

No. 533,218.

Patented Jan. 29, 1895.

Fig. 1.

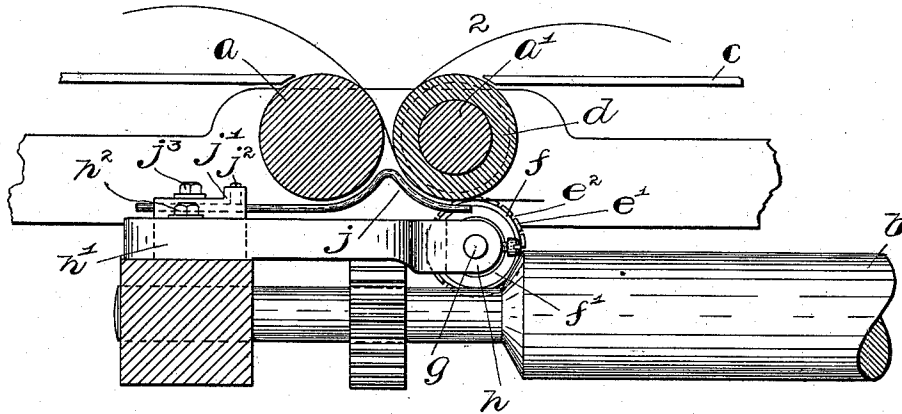
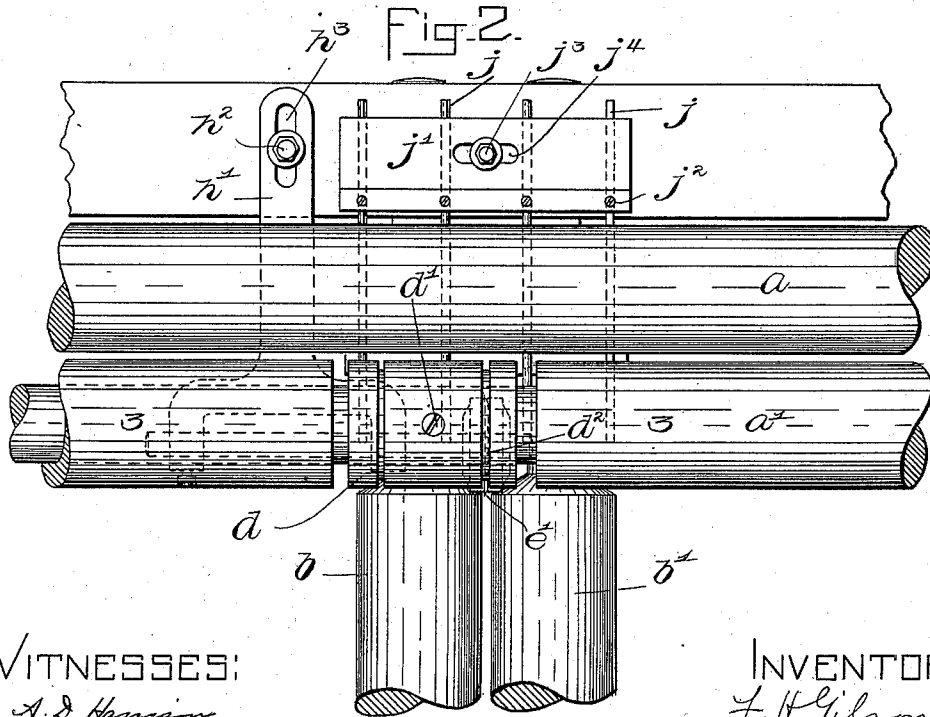

Fig. 2.



WITNESSES:

*A. D. Harrison*  
*T. Davis.*

INVENTORS

*F. H. Gilson*

*F. E. Reed*

*by Knight & Crossley*  
*Attys*

F. H. GILSON & F. E. REED.  
PAPER FOLDING MACHINE.

No. 533,218.

Patented Jan. 29, 1895.

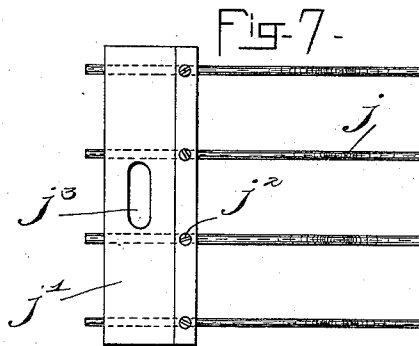
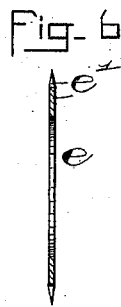
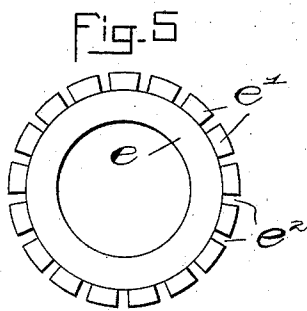
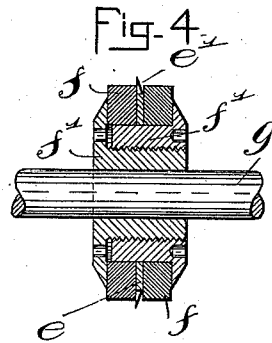
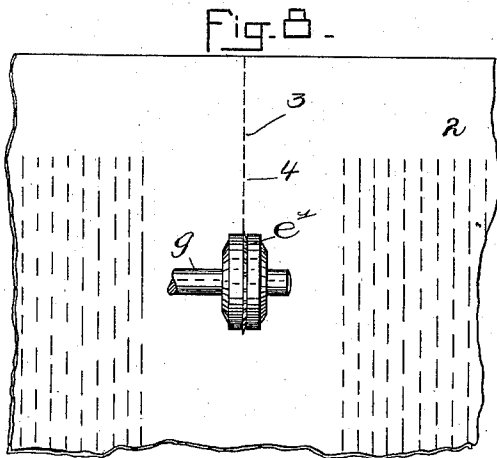
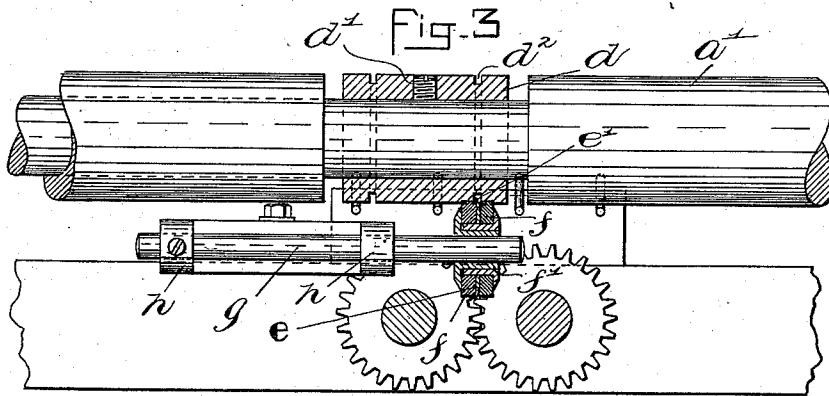

WITNESSES:

*A. D. Harrison.*

*J. P. Davis.*

INVENTORS

*F. H. Gilson*

*F. E. Reed*

*Wm. H. Brown*  
*Attys.*

(No Model.)

3 Sheets—Sheet 3.

F. H. GILSON & F. E. REED.  
PAPER FOLDING MACHINE.

No. 533,218.

Patented Jan. 29, 1895.

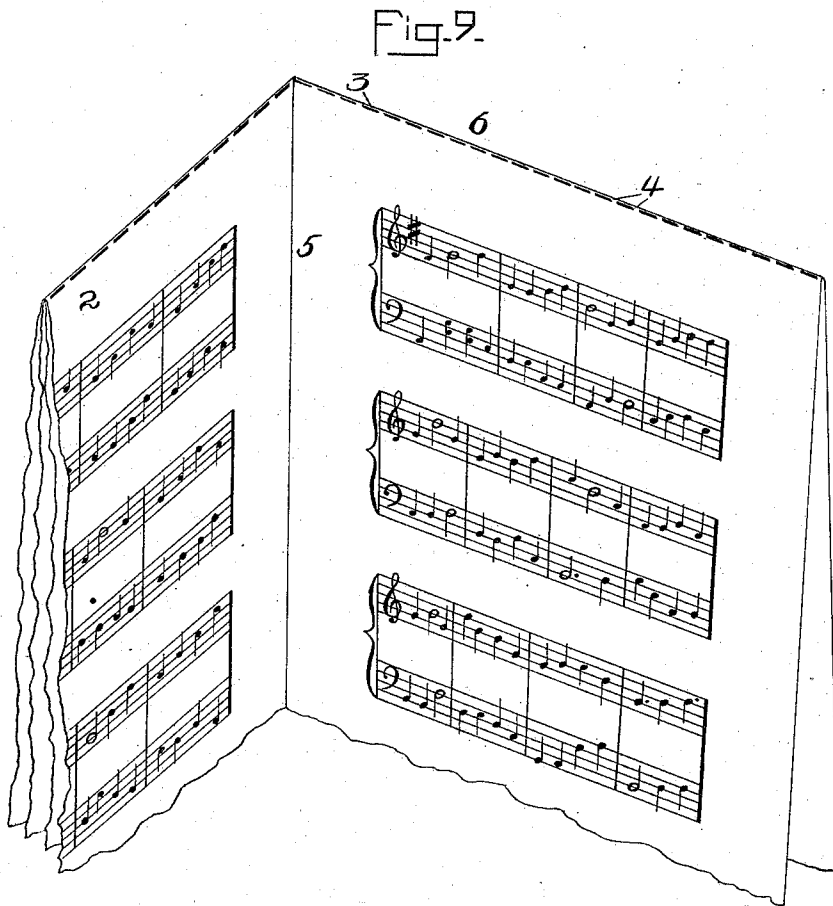

WITNESSES:

*A. D. Harrison*  
*C. Davis.*

INVENTORS

*F. H. Gilson*  
*F. E. Reed*  
by *Wright & Brown* Attorneys

# UNITED STATES PATENT OFFICE.

FRANKLIN H. GILSON, OF WELLESLEY, AND FRANCIS E. REED, OF BOSTON,  
MASSACHUSETTS.

## PAPER-FOLDING MACHINE.

SPECIFICATION forming part of Letters Patent No. 533,218, dated January 29, 1895.

Application filed March 30, 1894. Serial No. 505,749. (No model.)

*To all whom it may concern:*

Be it known that we, FRANKLIN H. GILSON, of Wellesley, in the county of Norfolk, and FRANCIS E. REED, of Boston, in the county of Suffolk, State of Massachusetts, have invented certain new and useful Improvements in Paper-Folding Machines, of which the following is specification.

The prime object of this invention is to provide means in a paper folding machine to prevent wrinkling of the paper in folding. In folding paper, as sheet-music, where one sheet is folded a number of times, after it has been twice folded the leaves will be confined so that subsequent folding produces wrinkles along the the preceding fold. To obviate this wrinkling the leaves must be disengaged so as to allow them to adjust themselves to the change in their relation effected by the fold. At the same time it is not desirable to completely sever the leaves as they would then have to be separately folded and additional mechanism would be required. It is highly desirable that the sheet be kept in one piece in its passage through the folding machine, for obvious reasons.

With the above in view the present invention contemplates forming a line of separated slits in the paper along the line of the one fold which will free the leaves from each other sufficiently to obviate wrinkling in making the next fold, enough paper being left between the slits to hold the leaves together while a folding blade acts on the paper on the line of the slits.

The invention consists in certain novel arrangements and combinations of parts for satisfactorily accomplishing the above-stated object, which are recited in the appended claim.

The accompanying drawings illustrate an embodiment of the invention.

Figure 1 shows a sectional view of a portion of a folding machine with the improvements applied thereto. Fig. 2 shows a plan view of the same portion of the machine. Fig. 3 shows a section on line 3—3 of Fig. 2. Fig. 4 shows an enlarged sectional detail of the rotary slitting device. Fig. 5 shows a detail elevation of the blade of the slitting device. Fig. 6 shows a sectional detail of a blade of

slightly modified construction. Fig. 7 shows a plan view of fingers and their support for holding the paper against one of the rolls. Fig. 8 illustrates the action of the slitting device on the paper. Fig. 9 shows the product of the machine.

In the drawings—the letters, *a*, and *a'*, designate the primary folding rolls of a folding machine of the well-known type such as commonly employed in folding printed sheets; and the letters, *b*, and *b'*, designate a second set of folding rolls whose axes extend at right angles to those of the rolls, *a*, and *a'*. The paper, 2, is laid over a table, *c*, and taken down between the rolls, *a*, and *a'*, by a folding blade, as usual, and passes thence over the rolls, *b*, and *b'*, between which it is folded by another blade, and then the paper passes to other folding devices, all in the well-known way.

In furtherance of the design of this invention the following devices are employed in connection with the above:

A sleeve, *d*, is mounted on the journal of the roll, *a'*, the latter being cut out at the middle to receive this sleeve and allow longitudinal adjustment thereof. The sleeve is affixed to the journal of the roll by a set-screw, *d'*, and the peripheral surface is flush with that of the roll. The said sleeve is formed with an annular groove, *d<sup>2</sup>*. A rotary slitting device has its blade engaged in said groove and said slitting device is of the following construction: Its blade, *e*, is annular and formed around its periphery with a series of separated cutting sections, *e'*, the peripheral edges only of which are sharpened to cut. The spaces, *e<sup>2</sup>*, between the cutting sections *e'*, are bounded by non-cutting edges. These cutting sections, *e'*, may be beveled on one side only, as shown in Fig. 4, to produce the cutting edges, or may be beveled on both sides, as shown in Fig. 6. The blade, *e*, is clamped between rubber disks, *f*, by means of interlocking screw-threaded thimbles, *f'*, having flanges to confine the disks.

The above described slitting device is loosely mounted on a stud or spindle, *g*, which engages the smooth bore of the inner thimble, *f'*. The slitter may move both longitudinally and rotatively on the spindle, *g*, and receives

its rotary motion by light engagement of the rubber disks, *f*, with the sleeve, *d*. Longitudinal adjustment of said sleeve effects longitudinal adjustment of the slitter by reason of the engagement of the latter's blade, *e*, in the groove, *d*<sup>2</sup>, and by this means the line in which said blade is to slit the paper is determined so as to insure coincidence of such line with that on which the second fold is made.

The stud or spindle, *g*, is affixed in ears, *h*, of a bracket, *h'*, and the latter is fastened to the frame of the machine by a bolt, *h*<sup>2</sup>, engaging a slot, *h*<sup>3</sup>, in the bracket. This slot provides for lateral adjustment of the slitter tangentially with respect to the sleeve *d* to determine the extent of entrance of the blade, *e*, into the groove, *d*<sup>2</sup>, and thereby the depth of penetration of the blade into the paper,—the number of layers of paper to be slit varying, and slitting of all the layers not being always necessary.

The slitter is located under the roll, *a'*, and in the operation of the machine the folded paper, 2, issuing from between the rolls, *a*, and *a'*, is subjected to the action of the slitter, and by reason of the peculiar formation of the blade thereof, as hereinbefore described, a line of slits, 3, will be made in the paper separated by portions, 4, of the paper. (See Fig. 8.)

The paper where it passes under the middle of the roll, *a'* is inclined to sag or bulge in the fold, and should it encounter the slitting blade while thus sagging or bulging, a slight wrinkle might be made. To avoid this, fingers, *j*, are arranged to hug the roll, *a'*, on each side of the slitter and thereby hold the paper close to the roll. These fingers are adjustably fastened in a holder, *j'*, being passed through holes drilled therein and secured by set-screws, *j*<sup>2</sup>. Said holder is fastened to the frame of the machine by a bolt, *j*<sup>3</sup>, extending

through a slot, *j*<sup>4</sup>, in the holder, said slot providing for lateral adjustment of the fingers. Through the means described a perfect adjustment of the fingers to the roll, *a'*, can be secured. The paper, 2, having left the roll, *a'*, and slitter, is acted upon by a folding blade which strikes it on the line of the slits, 3, and takes it down between the rolls, *b*, and *b'*. The connecting necks, 4, prevent severance of the paper. When the third fold, 5, is made in the paper the slits along the second fold, 6, free the leaves allowing adjustment thereof to suit their new relation, the necks, 4, twisting slightly. (See Fig. 9.) Hence, there will be an absence of wrinkles along the second fold.

It will be seen that the object primarily stated is accomplished by the construction described.

Having thus described our invention, what we claim as new, and desire to secure by Letters Patent, is—

In a folding machine the combination of a primary set of folding rolls, one having an annular groove, a rotary cutter whose blade engages said groove, fingers hugging the grooved roll on each side of the cutter, and adapted to press the paper against the roll and a holder for said fingers in which they are adjustably secured longitudinally, and which is itself adjustable to vary the lateral position of the fingers.

In testimony whereof we have signed our names to this specification, in the presence of two subscribing witnesses, this 27th day of March, A. D. 1894.

FRANKLIN H. GILSON.  
FRANCIS E. REED.

Witnesses:

A. D. HARRISON,  
F. P. DAVIS.