



US006436766B1

(12) **United States Patent**
Rangarajan et al.

(10) **Patent No.:** **US 6,436,766 B1**
(45) **Date of Patent:** ***Aug. 20, 2002**

(54) **PROCESS FOR FABRICATING HIGH DENSITY MEMORY CELLS USING A POLYSILICON HARD MASK**

(75) Inventors: **Bharath Rangarajan**, Santa Clara; **David K. Foote**, San Jose; **Fei Wang**, San Jose; **Dawn M. Hopper**, San Jose, all of CA (US); **Stephen K. Park**, Austin, TX (US); **Jack Thomas**, Palo Alto, CA (US); **Mark Chang**, Los Angeles, CA (US); **Mark Ramsbey**, Sunnyvale, CA (US)

(73) Assignee: **Advanced Micro Devices, Inc.**, Sunnyvale, CA (US)

(*) Notice: Subject to any disclaimer, the term of this patent is extended or adjusted under 35 U.S.C. 154(b) by 0 days.

This patent is subject to a terminal disclaimer.

(21) Appl. No.: **09/430,493**

(22) Filed: **Oct. 29, 1999**

(51) **Int. Cl.**⁷ **H01L 21/8247**

(52) **U.S. Cl.** **438/261; 438/262**

(58) **Field of Search** **438/257-267**

(56) **References Cited**

U.S. PATENT DOCUMENTS

- 5,661,072 A * 8/1997 Jeng 438/439
- 6,069,091 A * 5/2000 Chang et al. 438/719
- 6,261,904 B1 * 7/2001 Pham et al. 438/257

OTHER PUBLICATIONS

U.S. Patent application Ser. No. 09/429,722: "Process For Fabricating High Density Memory Cells Using A Metallic Hard Mask"; Inventors: Bharath Rangarajan, Fei Wang,

Dawn M. Hopper, David K. Foote, Stephen K. Park, Jack Thomas, Mark Chang, and Mark Ramsbey; Filed: Oct. 29, 1999; Attorney Docket No. 9076/423.

U.S. Patent application Ser. No. 09/627,563: "Integration of an ION Implant Hard Mask Structure Into a Process for Fabricating High Density Memory Cells"; inventors: David K. Foote, Bharath Rangarajan, Stephen K. Park, Fei Wang, Dawn M. Hopper, Jack Thomas, Mark Chang, and Mark Ramsbey; filed: Jul. 28, 2000; Attorney Docket No. 9076/426.

U.S. Patent application Ser. No. 09/429,909: "Process for Fabricating High Density Memory Cells Using a Silicon Nitride Hard Mask"; inventors: . Bharath Rangarajan, David K. Foote, Fei Wang, Dawn M. Hopper, Stephen K. Park, Jack Thomas, Mark Chang, and Mark Ramsbey; filed: Oct. 29, 1999; Attorney Docket No. 9076/442.

* cited by examiner

Primary Examiner—Richard Booth

(74) *Attorney, Agent, or Firm*—Amin & Turocy, LLP

(57) **ABSTRACT**

A process for fabricating a memory cell in a two-bit EEPROM device including forming an ONO layer overlying a semiconductor substrate, depositing a hard mask overlying the ONO layer, and patterning the hard mask. The hard mask is preferably made from polysilicon or silicon. The process further includes doping the semiconductor substrate with boron causing p-type regions to form in the semiconductor substrate, and doping the semiconductor substrate with n-type dopants, such as arsenic, causing n-type regions to form in the semiconductor substrate. The exposed ONO layer is then etched to expose part of the semiconductor substrate, and a bit-line oxide region is formed overlying the semiconductor substrate. The hard mask is then removed, preferably using a plasma etch process.

22 Claims, 6 Drawing Sheets

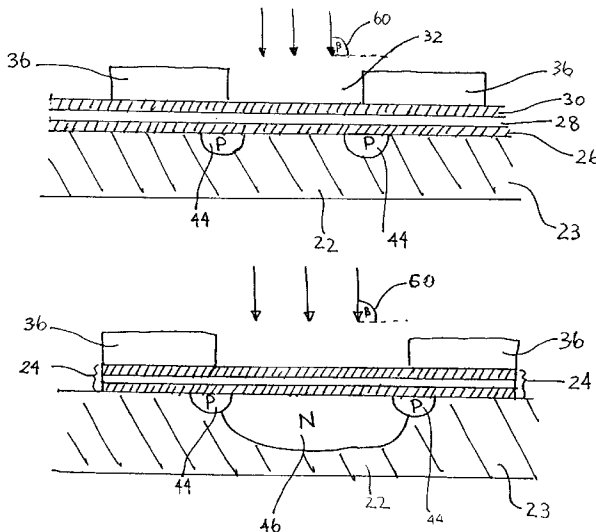

FIG. 1 (PRIOR ART)

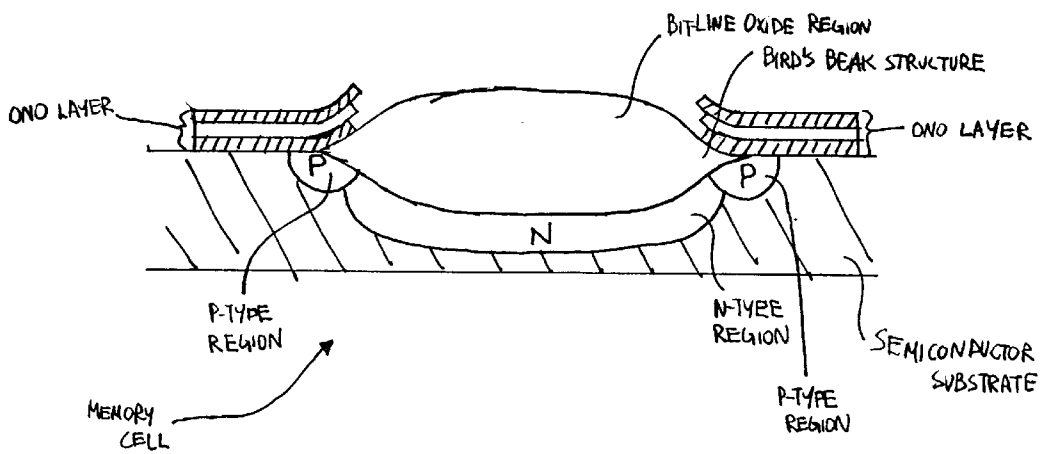

FIG. 2 (PRIOR ART)

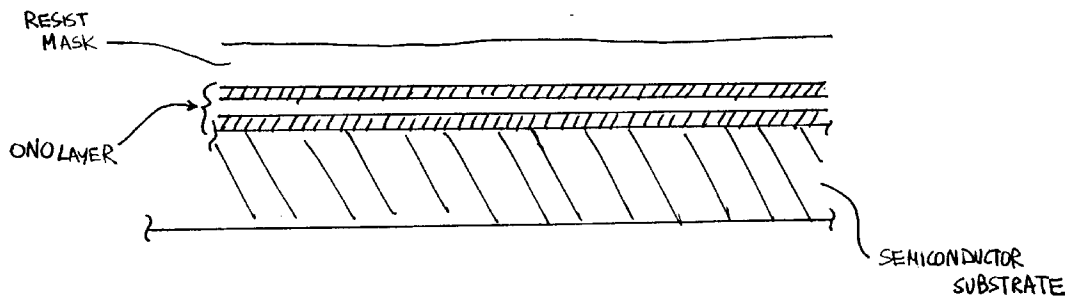

FIG. 3 (PRIOR ART)

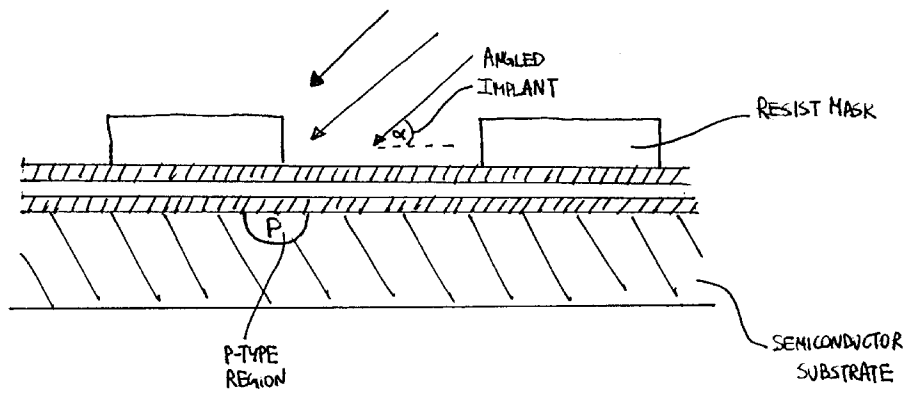

FIG. 4 (PRIOR ART)

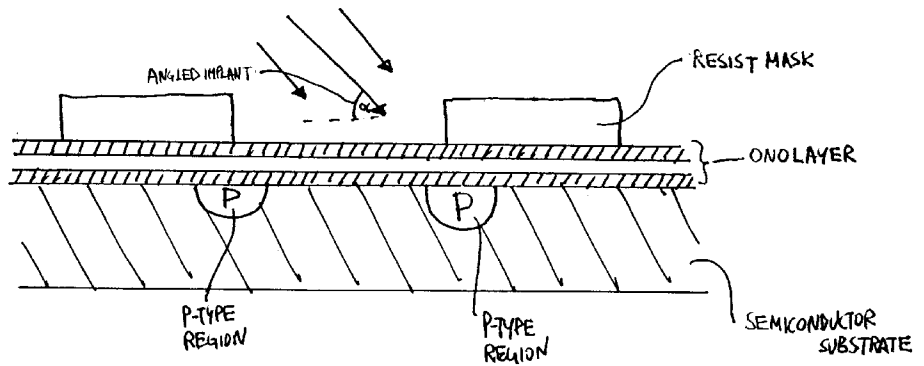

FIG. 5 (PRIOR ART)

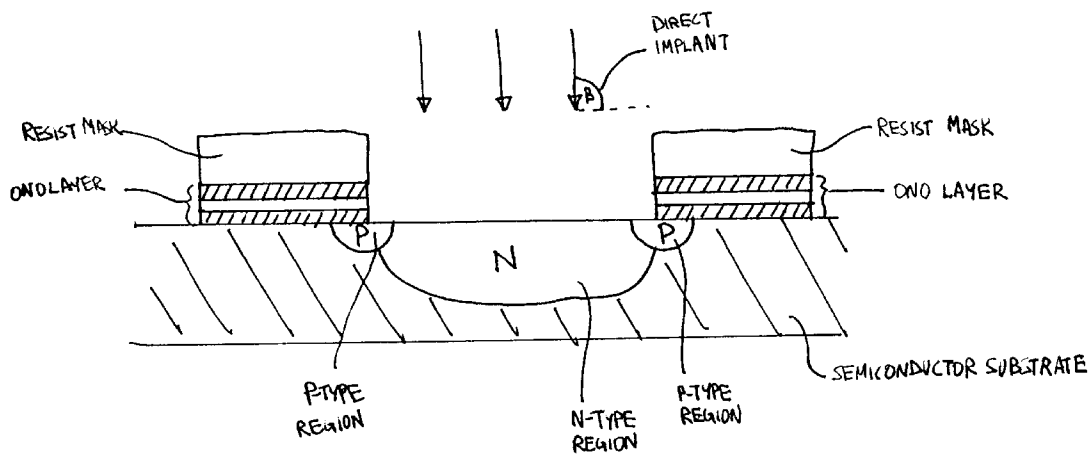

FIG. 6

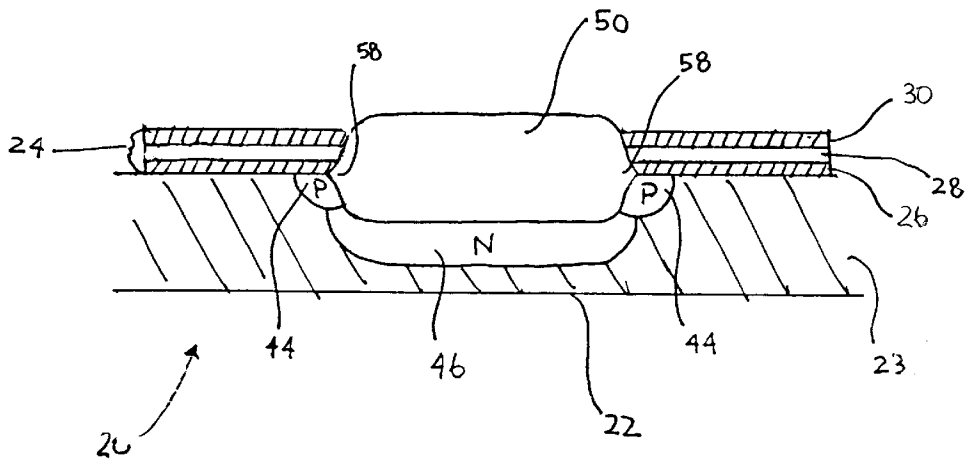

FIG. 7

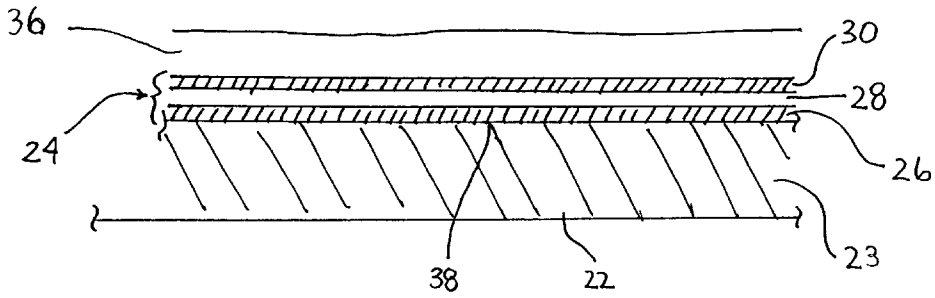

FIG. 8

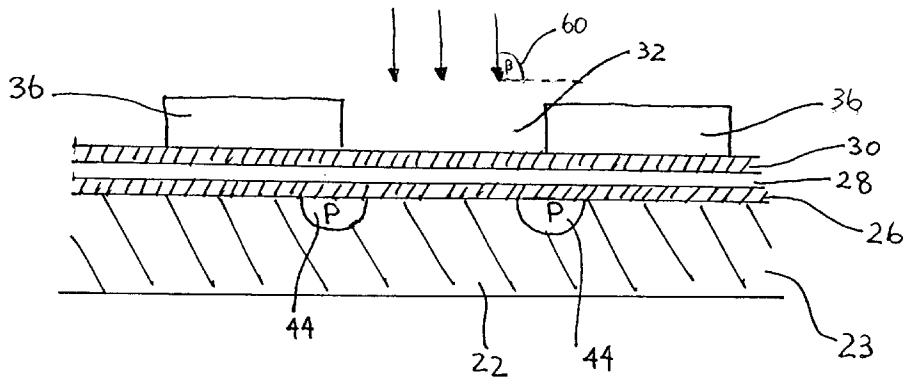

FIG. 9

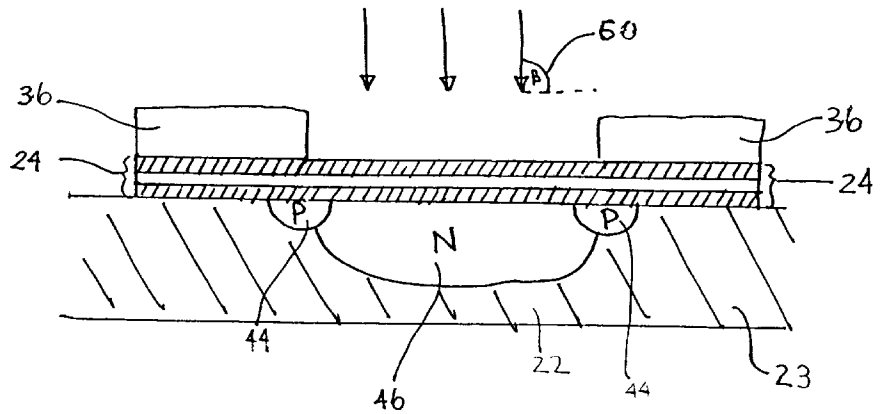
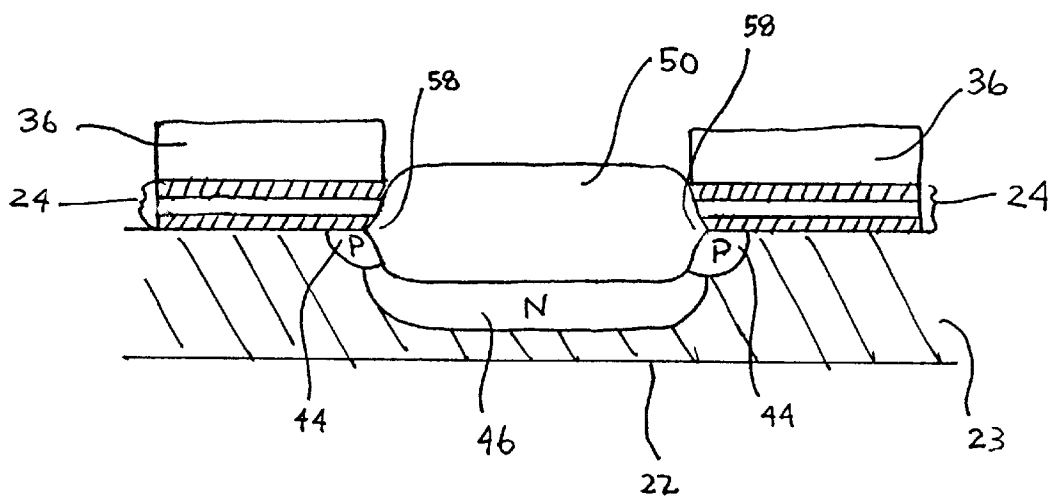

FIG. 10



PROCESS FOR FABRICATING HIGH DENSITY MEMORY CELLS USING A POLYSILICON HARD MASK

CROSS REFERENCE TO RELATED APPLICATIONS

Related subject matter is disclosed in commonly-assigned, co-pending U.S. patent application Ser. No. 09/429,722, which is entitled "PROCESS FOR FABRICATING HIGH DENSITY MEMORY CELLS USING A METALLIC HARD MASK" and was filed Oct. 29, 1999, and U.S. patent application Ser. No. 09/429,909, which is entitled "PROCESS FOR FABRICATING HIGH DENSITY MEMORY CELLS USING A SILICON NITRIDE HARD MASK" and was filed Oct. 29, 1999.

BACKGROUND OF THE INVENTION

Non-volatile memory devices are currently in widespread use in electronic components that require the retention of information when electrical power is terminated. Non-volatile memory devices include read-only-memory (ROM), programmable-read-only memory (PROM), erasable-programmable-read-only memory (EPROM), and electrically-erasable-programmable-read-only-memory (EEPROM) devices. EEPROM devices differ from other non-volatile memory devices in that they can be electrically programmed and erased. Flash EEPROM devices are similar to EEPROM devices in that memory cells can be programmed and erased electrically. However, Flash EEPROM devices enable the erasing of all memory cells in the device using a single electrical current pulse.

Typically, an EEPROM device includes a floating-gate electrode upon which electrical charge is stored. The floating-gate electrode overlies a channel region residing between source and drain regions in a semiconductor substrate. The floating-gate electrode together with the source and drain regions forms an enhancement transistor. By storing electrical charge on the floating-gate electrode, the threshold voltage of the enhancement transistor is brought to a relatively high value. Correspondingly, when charge is removed from the floating-gate electrode, the threshold voltage of the enhancement transistor is brought to a relatively low value. The threshold level of the enhancement transistor determines the current flow through the transistor when the transistor is turned on by the application of appropriate voltages to the gate and drain. When the threshold voltage is high, no current will flow through the transistor, which is defined as a logic 0 state. Correspondingly, when the threshold voltage is low, current will flow through the transistor, which is defined as a logic 1 state. Data resides in a certain logic state on the floating-gate electrode. During a read operation, selected data from a selected floating-gate electrode can be output to an external communication unit using a bit-line.

In a flash EEPROM device, electrons are transferred to a floating-gate electrode through a dielectric layer overlying the channel region of the enhancement transistor. The electron transfer is initiated by either hot electron injection, or by Fowler-Nordheim tunneling. In either electron transfer mechanism, a voltage potential is applied to the floating-gate by an overlying control-gate electrode. The control-gate electrode is capacitively coupled to the floating-gate electrode, such that a voltage applied on the control-gate electrode is coupled to the floating-gate electrode. The flash EEPROM device is programmed by applying a high positive voltage to the control-gate electrode, and a lower positive

voltage to the drain region, which transfers electrons from the channel region to the floating-gate electrode. The flash EEPROM device is erased by grounding the control-gate electrode and applying a high positive voltage through either the source or drain region of the enhancement transistor. Under erase voltage conditions, electrons are removed from the floating-gate electrode and transferred into either the source or drain regions in the semiconductor substrate.

Product development efforts in EEPROM device technology have focused on increasing the programming speed, lowering programming and reading voltages, increasing data retention time, reducing cell erasure times and reducing cell dimensions. Many of the foregoing research goals can be addressed through development of materials and processes for the fabrication of the floating-gate electrode. Recently, development efforts have focused on dielectric materials for fabrication of the floating-gate electrode. Silicon nitride in combination with silicon dioxide is known to provide satisfactory dielectric separation between the control-gate electrode and the channel region of the enhancement transistor, while possessing electrical characteristics sufficient to store electrical charge.

One important dielectric material for the fabrication of the floating-gate electrode is an oxide-nitride-oxide (ONO) layer. During programming, electrical charge is transferred from the substrate to the silicon nitride layer in the ONO layer. Voltages are applied to the gate and drain creating vertical and lateral electric fields, which accelerate the electrons along the length of the channel. As the electrons move along the channel, some of them gain sufficient energy to jump over the potential barrier of the bottom silicon dioxide layer and become trapped in the silicon nitride layer. Electrons are trapped near the drain region because the electric fields are the strongest near the drain. Reversing the potentials applied to the source and drain will cause electrons to travel along the channel in the opposite direction and be injected into the silicon nitride layer near the source region. Because silicon nitride is not electrically conductive, the charge introduced into the silicon nitride layer tends to remain localized. Accordingly, depending upon the application of voltage potentials, electrical charge can be stored in regions within a single continuous silicon nitride layer.

Non-volatile memory designers have taken advantage of the localized nature of electron storage within a silicon nitride layer and have designed memory devices that utilize two regions of stored charge within an ONO layer. This type of non-volatile memory device is known as a two-bit EEPROM. The two-bit EEPROM is capable of storing twice as much information as a conventional EEPROM in a memory array of equal size. A left and right bit is stored in physically different areas of the silicon nitride layer, near left and right regions of each memory cell. Programming methods are then used that enable two-bits to be programmed and read simultaneously. The two-bits of the memory cell can be individually erased by applying suitable erase voltages to the gate and to either the source or drain regions.

While the recent advances in EEPROM technology have enabled memory designers to double the memory capacity of EEPROM arrays using two-bit data storage, numerous challenges exist in the fabrication of material layers within these devices. In particular, fabricating the bit-line oxide region within a memory cell presents several challenges. Traditionally, bit-lines are fabricated using a resist mask, as illustrated in FIGS. 1-5. Referring to FIG. 2, an ONO layer is formed having a first silicon dioxide layer overlying the semiconductor substrate, a silicon nitride layer overlying the first silicon dioxide layer, and a second silicon dioxide layer

overlying the silicon nitride layer. A layer of photoresist is then spun on the ONO layer, as illustrated in FIG. 2. The photoresist is then patterned and the semiconductor substrate is doped with boron using ion implantation at an angle of about 25° to the principal surface of the semiconductor substrate, as illustrated in FIGS. 3-4. Doping the semiconductor substrate with boron creates p-type regions, as illustrated in FIGS. 3-4. The exposed ONO layer is then etched to expose part of the semiconductor substrate. The semiconductor substrate is doped with an n-type dopant such as arsenic using ion implantation at an angle substantially normal to the principal surface of the semiconductor substrate, as illustrated in FIG. 5. Doping the semiconductor substrate with n-type dopants, such as arsenic, creates n-type regions, as illustrated in FIG. 5. The ONO layer needs to be etched before the semiconductor substrate is doped with n-type dopants otherwise the implant of n-type dopants will not be a controlled implant. Once the n-type dopants have been implanted in the semiconductor substrate, the resist mask is stripped and cleaned from the ONO layer and a bit-line oxide region is thermally grown onto the semiconductor substrate, as shown in FIG. 1.

There are several problems that occur with the above described prior art method for fabricating a memory cell. First, it is difficult to pattern the memory cell on a reflective surface with good critical dimension control. Critical dimensions are the widths of the lines and spaces of critical circuit patterns as well as the area of contacts. In order to fabricate memory cells at high density, one needs to be able to pattern with good critical dimension control. Second, it is difficult to accurately control pocket implants or angled implants. When manufacturing the memory cell, pocket implants, such as p-type regions and n-type regions, are formed in the semiconductor substrate. These pocket implants can be created using n-type dopants or p-type dopants and are an essential component of the memory cell. Third, oxidizing structures, such as the bit-line oxide region, at high densities becomes difficult because of the formation of very large bird's beak structures, as illustrated in FIG. 1. Bird's beak structures form due to the differences in materials used and affect the critical dimensions of the memory cell, as illustrated by the curving of the ONO layer in FIG. 1. By increasing the distance between memory cells, bird's beak structures limit the amount of memory cells that can be placed on a two-bit EEPROM device. Fourth, overlay problems occur if the boron implant and the n-type dopant implant rely on two different masks. Accordingly, advances in memory cell fabrication technology are necessary to insure patterning of high density memory cells used in two-bit EEPROM devices.

SUMMARY OF THE INVENTION

The present invention is for a process for fabricating a memory cell in a two-bit EEPROM device. Fabrication of a two-bit EEPROM device having a memory cell requires the formation of a high quality bit-line oxide region. This is because proper functionality of the two-bit EEPROM device during a read operation requires selected data from a selected memory cell to be output to an external communication unit. The output of selected data is performed in the bit-line oxide region. In particular, the bit-line oxide region must have good critical dimension control as well as allow for high density devices. High density devices with good critical dimension control are hard to obtain due to the relatively large bird's beaks that are formed. By fabricating a high quality memory cell having a bit-line oxide region with good critical dimension control, a high-density two-bit EEPROM device can be manufactured.

In one form, a process for fabricating a memory cell includes providing a semiconductor substrate, and forming an ONO layer over the semiconductor substrate. A hard mask is then deposited overlying the ONO layer and patterned. The hard mask is made from polysilicon or silicon. The semiconductor substrate is then doped with boron, preferably by using ion implantation. The doping of the semiconductor substrate with boron causes p-type regions to form in the semiconductor substrate. The boron implant can be an angled implant, which is an implant at an angle substantially acute with respect to the principal surface of the semiconductor substrate. Alternatively, the boron implant can be a direct implant, which is an implant at an angle substantially normal with respect to the principal surface of the semiconductor surface. If the boron implant is a direct implant, the semiconductor substrate is then annealed causing the p-type regions to form under the hard mask. Next, the semiconductor substrate is doped with n-type dopants, such as arsenic, using ion implantation. The n-type dopant implant is a direct implant. The doping of the semiconductor substrate with n-type dopants causes n-type regions to form in the semiconductor substrate. The exposed ONO layer is then etched to expose part of the semiconductor substrate. Once the ONO layer is etched, the hard mask is not removed and a bit-line oxide region is formed overlying the semiconductor substrate. In one preferred embodiment, the ONO layer is etched prior to the n-type implant or the p-type implant. The hard mask acts as a structural member and provides support for the ONO layer during oxidation. By forming the bit-line oxide region with the hard mask still in place, the bit-line oxide region can form with little or no bird's beak structures. The hard mask is then removed, preferably using a plasma etch process.

BRIEF DESCRIPTION OF THE DRAWINGS

FIG. 1 illustrates, in cross-section, a portion of a semiconductor substrate containing a bit-line oxide region, formed in accordance with prior art methods for fabricating a memory cell;

FIGS. 2-5 illustrate, in cross-section, process steps for the fabrication of a memory cell, in accordance with prior art methods for fabricating a memory cell;

FIG. 6 illustrates, in cross-section, a portion of a semiconductor substrate containing a bit-line oxide region, in accordance with the invention; and

FIGS. 7-10 illustrate, in cross-section, process steps for the fabrication of a memory cell, in accordance with the invention.

It should be appreciated that for simplicity and clarity of illustration, elements shown in the Figures have not necessarily been drawn to scale. For example, the dimensions of some of the elements are exaggerated relative to each other for clarity. Further, where considered appropriate, reference numerals have been repeated among the Figures to indicate corresponding elements.

DETAILED DESCRIPTION OF PREFERRED EMBODIMENTS

Shown in FIG. 6, in cross-section, is memory cell 20 suitable for use in a two-bit EEPROM device. Please note that while all the FIGS. 1-10, illustrate only one memory cell 20, a two-bit EEPROM device may have thousands or even millions of memory cells identical to memory cell 20. For the sake of clarity, these additional memory cells have been left out of FIGS. 1-10.

Memory cell 20 includes p-type regions 44 and n-type regions 46 located in semiconductor substrate 22 and sepa-

rated by channel region **23**. Bit-line oxide region **50** overlies p-type regions **44** and n-type regions **46**, respectively. ONO layer **24** includes first silicon dioxide layer **26** overlying channel region **23**. Silicon nitride layer **28** overlies first silicon dioxide layer **26**. Second silicon dioxide layer **30** overlies silicon nitride layer **28**. In the operation of memory cell **20**, data resides in a certain logic state on memory cell **20**. During a read operation, selected data from a selected memory cell **20** can be output to an external communication unit by using n-type regions **46**. Those skilled in the art will recognize that in order to create higher density memory cells **20**, bit-line oxide region **50** must be patterned with good critical dimension control. In order to pattern bit-line oxide region **50** with good critical dimension control and create higher density memory cells **20**, bird's beak structures **58** must be reduced by suppressing oxide growth in bit-line oxide region **50**. Additionally, avoiding the use of angled implants will also aid in creating memory cells **20** with higher density, since angled implants place restrictions on resist thickness, thus preventing optimal lithography.

In accordance with this invention, a higher density memory cell **20** is achieved by using hard mask **36** instead of a resist mask. One advantage of hard mask **36** is that hard mask **36** can be used to improve photolithography by serving as an anti-reflective coating. An anti-reflective coating spun onto semiconductor substrate **22** can aid in the patterning of small images used in making high density memory cells **20**. An anti-reflective coating also brings several advantages to the masking process. First, the anti-reflective coating cuts down on light scattering from the surface into the mask, which helps in the definition of small images. Second, an anti-reflective coating can minimize standing wave effects and improve the image contrast. The use of hard mask **36** can also eliminate the use of angled implants, allowing for higher density memory cells **20**. Additionally, hard mask **36** can prevent extended growth of bird's beak structures **58**, by suppressing oxide growth in the bit-line oxide region **50**. Finally, hard mask **36** has no limitations on space size. The advantages obtained by the present invention can be better understood following a description of a process for fabricating a high density memory cell **20** having bit-line oxide region **50** carried out in accordance with this invention.

Referring to FIG. 7, ONO layer **24** is formed to overlie the surface of semiconductor substrate **22**. Preferably, semiconductor substrate **22** is a single crystal silicon substrate. Semiconductor substrate **22** has principal surface **38** previously processed to remove debris and native oxides. ONO layer **24** has first silicon dioxide layer **26**, silicon nitride layer **28**, and second silicon dioxide layer **30**. First silicon dioxide layer **26** is formed overlying the semiconductor substrate **22**. Preferably, first silicon dioxide layer **26** has a thickness of about 50 to about 150 angstroms and, more preferably, a thickness of about 80 angstroms. After forming first silicon dioxide layer **26**, silicon nitride layer **28** is formed overlying first silicon dioxide layer **26**, as illustrated in FIG. 7. Preferably, silicon nitride layer **28** is formed by reacting ammonia NH_3 with either dichlorosilane (SiCl_2H_2) or silane (SiH_4). After forming silicon nitride layer **28**, second silicon dioxide layer **30** is formed overlying silicon nitride layer **28**, as illustrated in FIG. 7. Preferably, second silicon dioxide layer **30** has a thickness of about 50 to 150 angstroms and, more preferably, a thickness of about 80 angstroms.

Once ONO layer **24** has been formed, hard mask **36** is deposited overlying ONO layer **24**. Hard mask **36** comprises a material selected from the group consisting of polysilicon

and silicon. Preferably, hard mask **36** comprises polysilicon since polysilicon is known to be an effective anti-reflective coating which helps in the formation of the p-type region **44** and n-type region **46**. Additionally, if hard mask **36** comprises either polysilicon or silicon, hard mask **36** can be removed from ONO layer **24** without causing much damage to ONO layer **24**. After hard mask **36** has been deposited, a resist mask is deposited overlying hard mask **36**. Preferably, the resist mask is exposed to a light source, or x-ray source, which allows for the patterning of the resist mask. Once the resist mask has been patterned, hard mask **36** is etched and patterned. Following the patterning of hard mask **36**, the resist mask is removed.

Once resist mask has been removed, semiconductor substrate **22** is then doped with a p-type dopant using hard mask **36** as a doping mask. Preferably, the p-type dopant is boron. In one preferred embodiment of this invention, the semiconductor substrate **22** is doped with boron by using ion implantation. Ion implantation allows for the fabrication of memory cell **20** with higher density and smaller feature sizes. A boron implant (for example about $1 \times 10^{12} \text{cm}^{-2}$ at about 20 Kev to about $3 \times 10^{13} \text{cm}^{-2}$ at about 80 Kev, and more preferably about $2 \times 10^{13} \text{cm}^{-2}$ at about 60 Kev) is performed to fix the threshold voltage of the select transistor. The implant is performed through ONO layer **24**, but is masked out by hard mask **36**, as illustrated in FIG. 8. The boron implant may be an angled implant performed at an acute angle to the principal surface **38** of the semiconductor substrate **22**, such as about a 25° angle, or the boron implant may be a direct implant **60** performed at an angle substantially normal to the principal surface **38** of the semiconductor substrate **22**, such as about a 90° angle, as illustrated in FIG. 8. If the boron implant is a direct implant **60**, then semiconductor substrate **22** must be annealed. Annealing semiconductor substrate **22** after the boron implant forces the boron implant in semiconductor substrate **22** to move away from open region **32** and form p-type regions **44** underneath hard mask **36**, as illustrated in FIG. 8. Performing the boron implant at an angle substantially normal to the principal surface **38** of the semiconductor substrate **22** allows for the fabrication of higher density memory cells **20** since there are no limits placed on resist mask thickness. Since the boron implant must be annealed after a direct implant **60**, the mask overlying ONO layer **24** must be a hard mask such as hard mask **36** and not a resist mask, such as that used in prior art fabrication methods, because unlike hard mask **36**, a resist mask cannot survive the annealing process.

Once semiconductor substrate **22** has been doped with boron, forming p-type regions **44**, semiconductor substrate **22** is doped with an n-type dopant, as illustrated in FIG. 9. In one preferred embodiment of this invention, semiconductor substrate **22** is doped with an n-type dopant by using ion implantation. Preferably, n-type dopant comprises an element selected from the group consisting of antimony, arsenic, and phosphorus. In one preferred embodiment of this invention, semiconductor substrate **22** is doped with arsenic. Using the same hard mask **36**, an arsenic implant (for example about $1 \times 10^{14} \text{cm}^{-2}$ at about 20 Kev to about $5 \times 10^{16} \text{cm}^{-2}$ at about 80 Kev, and more preferably about $3 \times 10^{15} \text{cm}^{-2}$ at about 50 Kev) is then performed. The arsenic implant provides a high breakdown voltage for the drain node, which is needed during cell erasure. The arsenic implant also forms the buried bit-line, which is a sub-surface conductive channel that carries a signal to each bit in the memory cell **20**. The implant is performed through ONO layer **24**, but is masked out by hard mask **36**, as illustrated

in FIG. 9. Preferably, the arsenic implant is a direct implant **60** performed at an angle substantially normal to the principal surface **38** of the semiconductor substrate **22**, such as about a 90° angle, as illustrated in FIG. 9. While the above ion implantation has been described with respect to arsenic, as will be appreciated by those of skill in the art, the same ion implantation may be readily accomplished with any other n-type dopant such as antimony or phosphorus.

Once semiconductor substrate **22** has been doped with p-type and n-type dopants, the exposed ONO layer **24** is etched to expose part of semiconductor substrate **22**. While in the above embodiment, the step of etching the exposed ONO layer **24** to expose part of the semiconductor substrate **22** is performed after the step of doping the semiconductor substrate **22** with p-type and n-type dopants, the step of etching the exposed ONO layer **24** to expose part of the semiconductor substrate **22** may be performed before the step of doping the semiconductor substrate **22** with p-type dopant or before the step of doping the semiconductor substrate **22** with n-type dopant.

Once the ONO layer **24** has been etched and the semiconductor substrate **22** has been doped with p-type and n-type dopants, bit-line oxide region **50** is formed overlying the exposed semiconductor substrate **22**, as illustrated in FIG. 10. Bit-line oxide region **50** is formed by growing a layer of silicon dioxide into and on top of the exposed semiconductor substrate **22**. Because of the use of hard mask **36**, bit-line oxide region **50** can be formed with hard mask **36** in place over ONO layer **24**, as illustrated in FIG. 10. By forming bit-line oxide region **50** with hard mask **36** in place, the growth of bird's beak structures **58** can be kept to a minimum. Growth of bird's beak structures **58** is kept to a minimum because hard mask **36** acts a structural support member for ONO layer **24**, preventing ONO layer **24** from curving upwards, as illustrated in FIG. 10 and FIG. 6. Keeping the growth of bird's beak structures **58** to a minimum allows the formation of memory cell **20** with greater critical dimension control and higher density than prior art methods.

After bit-line oxide region **50** is formed, hard mask **36** is removed from semiconductor substrate **22** and semiconductor substrate **22** is cleaned. In one preferred embodiment of this invention, hard mask **36** is removed and semiconductor substrate **22** is cleaned by preferably using a plasma etch process, however hard mask **36** can be removed and semiconductor substrate **22** can be cleaned using other comparable methods or processes known to those skilled in the art. A plasma etch process is a dry-etch process using reactive gases and plasma energy to cause a chemical reaction. For the etching of polysilicon or silicon, the reactive gases used in the plasma etch process are usually a combination of chlorine, helium, or hydrogen bromide. However other gases or combinations of gases known to those skilled in the art can also be used in the plasma etch process. Use of the plasma etch process is preferred because the plasma etch process will selectively remove the polysilicon or silicon without substantially affecting the underlying ONO layer.

Thus, there has been disclosed in accordance with the invention, a process for fabricating a memory cell using a hard mask that fully provides the advantages set forth above. Although the invention has been described and illustrated with reference to specific illustrative embodiments thereof, it is not intended that the invention be limited to those illustrative embodiments. Those skilled in the art will recognize that variations and modifications can be made without departing from the spirit of the invention. It is therefore intended to include within the invention all such variations

and modifications that fall within the scope of the appended claims and equivalents thereof.

What is claimed is:

1. A process for fabricating a memory cell comprising: depositing a hard mask overlying an ONO layer, wherein the hard mask comprises a material selected from the group consisting of polysilicon and silicon, the ONO layer is formed over a semiconductor substrate having a principal surface, and the ONO layer has a first silicon dioxide layer overlying the semiconductor substrate, a silicon nitride layer overlying the first silicon dioxide layer, and a second silicon dioxide layer overlying the silicon nitride layer;
- applying a layer of resist overlying the hard mask; patterning the hard mask; doping the semiconductor substrate with boron using the hard mask as a doping mask; doping the semiconductor substrate with an n-type dopant using the hard mask as a doping mask;
- etching the exposed ONO layer to expose part of the semiconductor substrate;
- forming a bit-line oxide region overlying the exposed semiconductor substrate; and
- removing the hard mask.
2. The process of claim 1 further comprising removing the hard mask using a plasma etch process.
3. A process for making an electronic device comprising: forming a memory cell by the process of claim 2; and forming the electronic device comprising the memory cell.
4. The process of claim 1, wherein the etching of the exposed ONO layer to expose part of the semiconductor substrate is performed before the doping of the semiconductor substrate with boron.
5. The process of claim 1, wherein the etching of the exposed ONO layer to expose part of the semiconductor substrate is performed after the doping of the semiconductor substrate with boron.
6. The process of claim 1, wherein the doping of the semiconductor substrate with boron comprises the using of ion implantation at an angle substantially normal to the principal surface of the semiconductor substrate.
7. The process of claim 6 further comprising the annealing of the semiconductor substrate after the doping of the semiconductor substrate with boron.
8. The process of claim 7, wherein the annealing of the semiconductor substrate comprises the annealing of the semiconductor substrate in an RTA furnace.
9. The process of claim 1, wherein the n-type dopant comprises a material selected from the group consisting of antimony, arsenic, and phosphorus.
10. The process of claim 1, wherein the doping of the semiconductor substrate with an n-type dopant comprises the using of ion implantation at an angle substantially normal to the principal surface of the semiconductor substrate.
11. The process of claim 1, wherein the hard mask comprises a material selected from the group consisting of polysilicon and silicon.
12. The process of claim 11, wherein the removing of the hard mask comprises the using of a plasma etch process.
13. A process for fabricating a memory cell comprising the steps of:
 - providing a semiconductor substrate having a principal surface comprising silicon;
 - forming an ONO layer over the semiconductor substrate, the ONO layer having a first silicon dioxide layer

overlying the semiconductor substrate, a silicon nitride layer overlying the first silicon dioxide layer, and a second silicon dioxide layer overlying the silicon nitride layer;

- 5 depositing a hard mask overlying the ONO layer, wherein the hard mask comprises a material selected from the group consisting of polysilicon and silicon;
- 10 patterning the hard mask;
- 15 implanting the semiconductor substrate with a p-type dopant using the hard mask as an ion implant mask;
- 20 implanting the semiconductor substrate with an n-type dopant using the hard mask as an ion implant mask;
- 25 etching the exposed ONO layer to expose part of the semiconductor substrate;
- 30 forming a bit-line oxide region overlying the exposed semiconductor substrate; and
- 35 removing the hard mask.

14. The process of claim 13, wherein the step of implanting the semiconductor substrate with a p-type dopant comprises the step of implanting the semiconductor substrate with a p-type dopant at an angle substantially normal to the principal surface of the semiconductor substrate.

15. The process of claim 14 further comprising the step of annealing the semiconductor substrate after the step of implanting the semiconductor substrate with a p-type dopant.

16. The process of claim 13, wherein the step of removing the hard mask comprises the step of using a plasma etch process.

17. The process of claim 13, wherein the first silicon dioxide layer, the silicon nitride layer, and the second silicon dioxide layer each have a thickness of about 50 to 110 angstroms.

18. The process of claim 13, wherein the hard mask has a thickness of about 300 to 2000 angstroms.

19. A process for fabricating a memory cell comprising: providing a semiconductor substrate having a principal surface; layer having a first silicon dioxide layer overlying the semiconductor substrate, a silicon nitride layer overlying the first silicon dioxide layer, and a second silicon dioxide layer overlying the silicon nitride layer;

depositing a hard mask overlying the ONO layer, wherein the hard mask comprises a material selected from the group consisting of polysilicon and silicon;

- 5 patterning the hard mask;
- 10 implanting the semiconductor substrate with boron ions using the hard mask as an ion implant mask;
- 15 implanting the semiconductor substrate with n-type dopants using the hard mask as an ion implant mask;
- 20 etching the exposed ONO layer to expose part of the semiconductor substrate;
- 25 forming a bit-line oxide region overlying the exposed semiconductor substrate; and
- 30 removing the hard mask using a plasma etch process.

20. The process of claim 19, wherein the implanting of the semiconductor substrate with boron ions comprises the implanting of the semiconductor substrate with boron ions at an angle substantially normal to the principal surface of the semiconductor substrate.

21. The process of claim 20 further comprising the annealing of the semiconductor substrate after the implanting of the semiconductor substrate with boron ions.

22. A process for fabricating a memory cell comprising: providing a semiconductor substrate having a principal surface comprising silicon;

forming an ONO layer over the semiconductor substrate, the ONO layer having a first silicon dioxide layer overlying the semiconductor substrate, a silicon nitride layer overlying the first silicon dioxide layer, and a second silicon dioxide layer overlying the silicon nitride layer;

depositing a hard mask overlying the ONO layer, wherein the hard mask comprises a material selected from the group consisting of polysilicon and silicon;

- 35 patterning the hard mask; and
- 40 implanting the semiconductor substrate with a dopant using the hard mask as an ion implant mask.

* * * * *