

March 26, 1963

G. W. HILL

3,082,555

WEAR CAP FOR EXCAVATING TOOTH

Filed Aug. 26, 1960

Fig. 1.

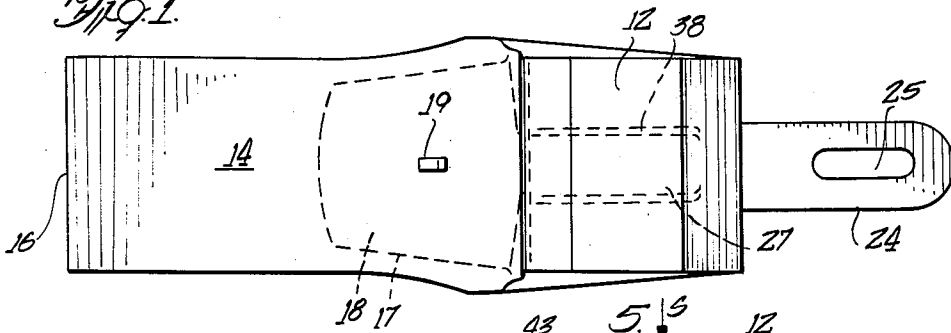

Fig. 2.

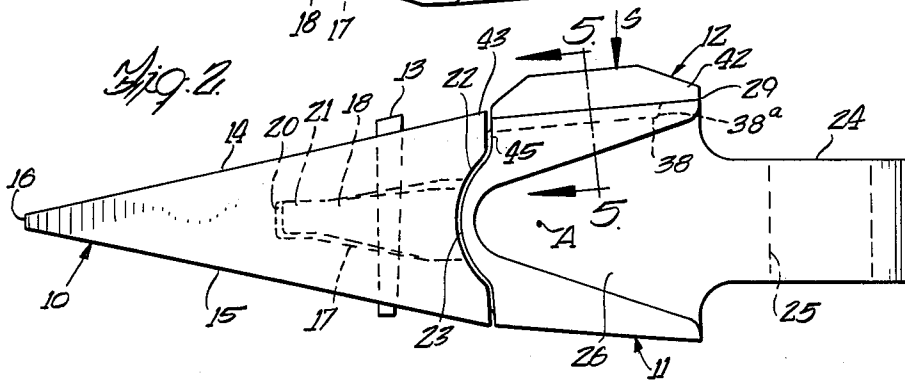

Fig. 3.

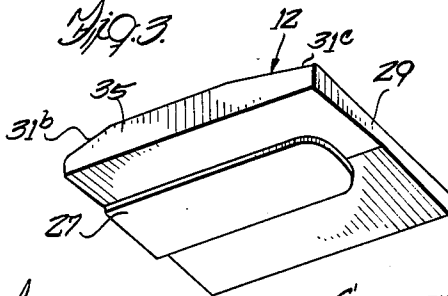

Fig. 4.

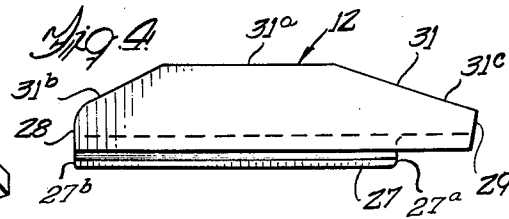
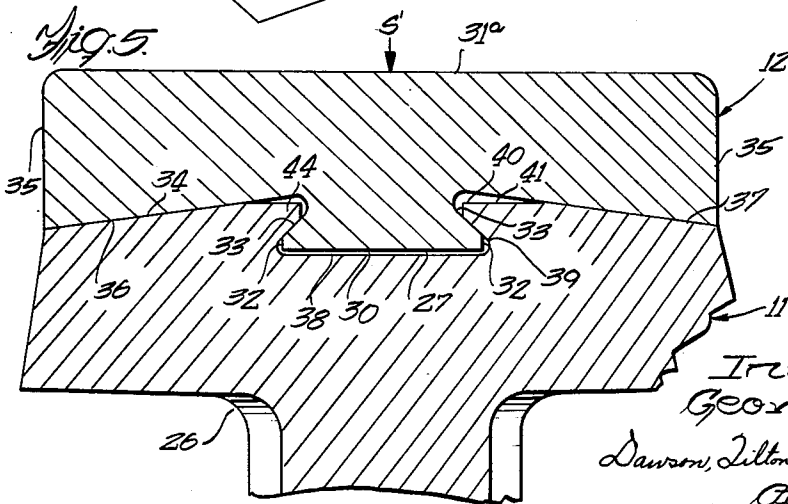

Fig. 5.



Inventor
George W. Hill
Dawson, Dillon, Fallon & Livingston
Attorneys

1

3,082,555

WEAR CAP FOR EXCAVATING TOOTH

George W. Hill, Newberg, Oregon, assignor to Esco Corporation, Portland, Oreg., a corporation of Oregon
 Filed Aug. 26, 1960, Ser. No. 52,176
 5 Claims. (Cl. 37-142)

This invention relates to a wear cap for an excavating tooth and, more particularly to a replaceable element employed in conjunction with the adapter or tooth holder element of the composite tooth.

Digger teeth are employed on a wide variety of material handling equipment. As such, they are subject to considerable wear, the main areas of wear being along the front or cutting edge and the top surface of the tooth. Conventionally, a tooth includes an adapter which is fixed to the main frame of the excavating device and a replaceable wedge shaped point mounted on the adapter. Although the point may be detached from the adapter without difficulty, it is much more difficult to remove the adapter itself from the excavating machine. Thus, it is important to minimize wear on the adapter, particularly the top surface thereof and for this purpose, replaceable wear caps have been proposed.

The prior art wear caps have only imperfectly fulfilled their objective of conserving the operating life of the expensive and hard to install adapter. Not only have the wear caps worn out quickly but in the course of their wear have been accompanied by corresponding wear on the adapter. The frequency of replacement of wear caps is undesirable since it is usually accompanied by prior removal of the point so that it would be desirable to provide a wearable element in the form of a wear cap that has a substantial operating life. Such constitutes an object of this invention.

Another object is to provide a novel wear cap characterized by an elongated tongue-like projection positioned centrally of the lower surface and which is adapted to engage a correspondingly positioned groove or recess in the top surface of the adapter. Still another object is to provide a wear cap having a longitudinally extending, integral tongue-like projection positioned centrally on the lower cap surface and wherein the lower surface adjacent the tongue is outwardly and downwardly inclined. Yet another object is to provide a novel composite tooth which is characterized by having a wear cap uniquely interfitted with an adapter and which is characterized by substantial resistance to wear.

Other objects and advantages of the invention may be seen in the details of construction and operation as set down in this specification.

The invention will be explained in conjunction with an illustrated embodiment in the accompanying drawing in which—

FIG. 1 is a top plan view of a tooth assembly embodying teachings of this invention;

FIG. 2 is a side elevational view of the tooth assembly seen in FIG. 1;

FIG. 3 is a perspective view of the wear cap portion of the assembly seen in FIGS. 1 and 2;

FIG. 4 is a side elevational view of the wear cap of FIG. 3; and

FIG. 5 is an enlarged fragmentary cross-sectional view

2

of a portion of the assembly of FIG. 2 as would be seen along the sight line 5-5.

In the illustration given and with particular reference to FIG. 2, the numeral 10 designates generally a tooth point, the numeral 11 generally a tooth adapter, the numeral 12 generally a wear cap and the numeral 13 a locking pin.

The point 10 is generally wedge shaped as can be appreciated from a consideration of FIG. 2 being equipped with top and bottom angularly related surfaces 14 and 15 which cooperate to define a cutting edge 16. Interiorly, the tooth point 10 is equipped with a socket 17 in which is received the nose portion 18 of the adapter 11. The nose portion 18 and the point 10 are equipped with aligned openings as at 19 in FIG. 1, to accommodate the receipt of the locking pin 13.

When the point is to be mounted on the adapter, the point 10 is moved longitudinally to position the nose portion 18 within the socket 17 after which the locking pin or key 13 is installed in the aligned openings 19. It will be appreciated that this general mounting movement may be followed in points in adapters having other telescoping or interlocking configurations than that shown. For example, it is common in some instances to reverse the locations of the socket and nose portion on the point and adapter.

In the illustration given, the socket 17, as seen in FIG. 2, is seen to have a box shaped apex as at 20 which accommodates the receipt of a generally similarly contoured box shaped tip 21 on the nose portion 18. The general contour of the socket 17 and the nose portion 18 conform to the showing set forth in greater detail in the co-owned, co-pending application of Paul V. Larsen, Paul Eyolfson and George W. Hill, Serial No. 50,655, filed Aug. 19, 1960, now abandoned. I have found that the wear cap of the instant invention provides extremely advantageous operation with the tooth of the above mentioned co-pending application.

As also seen in FIG. 2, the point 10 is concavely recessed as at 22 and mates with a conforming convex projection 23 on the adapter 11. The surfaces 22 and 23 are preferably surfaces of revolution generated about a horizontal axis, as designated by the point A in FIG. 2.

The adapter 11 includes an integral shank portion 24 apertured as at 25 for the receipt of a locking element (not shown) so as to secure the adapter 11 to the mold board or other digging surface of a piece of excavating equipment (also not shown). The adapter may conveniently be recessed along the sides thereof as at 26 (compare FIGS. 2 and 5) to accommodate the receipt of the mold board or like structure.

The wear cap 12 is seen in greater detail in FIGS. 3-5 and is seen to include a unitary metal body having in general what might be considered to be a plate like form. The wear cap 12 is equipped with a longitudinally extending tongue 27 which extends from the forward wall 28 of the wear cap to a point spaced forwardly of the rear wall 29 of the wear cap (see particularly FIGS. 3 and 4). As can be appreciated from FIG. 5, the tongue 27 is generally trapezoidal in cross-section. More particularly, the tongue 27 is defined by a lower surface 30 generally parallel with the central portion 31a of the top surface 31 of the wear cap 12. The longitudinally extending sides of the tongue 27 include angularly related

3

portions 32 and 33 (seen only in FIG. 5), the portions 32 being generally normal to the portion 31a while portions 33 are upwardly and inwardly inclined.

The lower wall surface of the cap 12 which is designated by the numeral 34 is seen to be downwardly and outwardly inclined from the tongue 27 toward the side walls 35 of the cap 12. Excellent results are obtained when the inclination of the lower wall 34 is of the order of about 7° relative to the plane of the top wall portion 31a, i.e., the inclined angle between the side portions of the lower wall 34 being of the order of 166°.

The adapter 11 in the top wall 36 thereof, is generally similarly contoured to the lower wall 34 of the cap 12. The upper surface 36 of the adapter 11 is seen to be laterally downwardly inclined as at 37 and centrally thereof is equipped with a recess or tongue-receiving groove 38. The groove 38 is equipped with rounded longitudinally extending corners as at 39 and square corners as at 40. The upper surface 36 is substantially free of inclination in the portion 41 thereof which is immediately adjacent the groove 38.

The wear cap 12 is seen to include a forward bevelled portion 31b and a rearward bevelled portion 31c in the top wall 31 thereof (designated only in FIGS. 3 and 4).

In the operation of the device described, the adapter may be first mounted on the piece of excavating machinery on which it is intended to be used. Thereafter, the wear cap 12 is slideably mounted on the top wall 36 of the adapter 11 which the tongue 27 fitting within the groove 38. In the illustration given, the groove 38 extends only part way rearwardly of the top wall 36 from the point mounting nose portion 18 so that a portion 42 (see FIG. 2) of the cap overlaps the adapter. The rear wall 29 of the cap 12 thus may be positioned to extend above the adapter 11 and any associated mold board so as to provide a bearing surface for hammer blows when it is desired to remove the cap 12. The rear end of the tongue 27 is seen in FIG. 2 to abut the rear end of the groove 38 which is equipped with a rear bearing surface as at 38a, and thus the rear surface 27a of the tongue provides a coating bearing surface limiting the rearward movement of the cap 12 on the adapter 11. Generally, then, the mounting and removal of the cap 12 on the adapter 11 is accompanied by movement over a path generally similar to the path of movement of the point when it is installed or removed from the adapter 11. After the cap 12 has been installed, the point 10 and locking key 13 are installed as outlined above, the point 10 in the portion 43 thereof (see FIG. 2) serving as an abutment to prevent the cap 12 from shifting forwardly on the adapter 11. Thus the forward surface 27b of the tongue 27 also serves as a bearing surface to limit forward movement of the cap 12 on the adapter 11.

When the composite structure is employed in material handling, tremendous shock stresses S (see FIG. 2) are applied to the top of the tooth structure, particularly the wear cap 12. The imposition of these stresses reinforces the locking engagement between the cap 12 and the adapter 11 in contrast to the effect such stresses had on prior analogous structures where the imposition of the usually encountered stresses tended to weaken the locking connection. The stress S' as seen in FIG. 5 tends to drive the tongue 27 more firmly into the recess or groove 38 and without distorting the lip-like portions 44 of the adapter 11. It will be appreciated that any substantial wear or distortion of the lip-like portions 44 is doubly undesirable. First, mutilation of the portions 44 may result in the accidental dislodgement and loss of the wear cap 12. Secondly, distortion of these lip portions 44 may effectively preclude the installation of another wear cap 12 so that the adapter itself must be discarded or rehabilitated.

The conforming downwardly inclined portion 34 and 37 result in the provision of a massive wear section along the longitudinal edges of the cap 12 so as to effectively

4

prolong the operational life of the wear cap. The massivity of the longitudinal side portions of the wear cap further aids in rigidifying the entire wear cap so as to effectively avoid distorting the lip portions 44 of the adapter 11.

The groove 38, as can be appreciated from a consideration of FIGS. 1 and 2, extends forwardly in the top wall 36 of the adapter 11 to a point adjacent the shoulder 45 (see FIG. 2). Thus the wear cap 12 is readily and conveniently installed on the adapter 11. By providing the adapter top wall 36 in the configuration illustrated, there is a minimum of recessing which tends to maintain the strength of the forward upper portion of the adapter, i.e., the portion immediately rearward and above the nose portion 18.

While in the foregoing specification I have set forth a detailed description of an embodiment of the invention for the purpose of illustration thereof, many variations in the details herein given may be made by those skilled in the art without departing from the spirit and scope of the invention.

I claim:

1. In an excavating tooth,

(A) an elongated adapter equipped with
 (1) a point-receiving nose at the forward end thereof,
 (2) shank means at the rear end thereof for securing the adapter to excavating equipment, and
 (3) top, bottom and side surfaces extending between said nose and shank means, said top surface having

(i) a longitudinally-extending, centrally disposed recess therein, said recess extending only partway longitudinally of said top surface from said nose and defining a rear bearing surface, said recess being generally trapezoidal in a transverse direction,

(ii) a top surface portion adjacent each side surface being angularly downwardly inclined toward its associated side surface,

(B) a wear cap mounted on said adapter, comprising a plate-like body including top, bottom, end, and side walls, said bottom wall being equipped with

(1) a centrally disposed tongue extending parallel to said side walls, said tongue having a trapezoidal shape in transverse section for sliding locking receipt in said recess from the nose end of said recess,

(2) a bottom wall portion adjacent each side wall being angularly downwardly inclined toward its associated side wall and bearing against a top surface portion,

(C) a point on said nose, said point having an upper end portion in confronting relation with the forward end wall of said tongue and with the rear end wall of said tongue being in confronting relation with said rear bearing surface whereby movement of said cap longitudinally of said adapter is limited, and

(D) means releasably locking said point on said nose.

2. The structure of claim 1 in which the said top wall is generally flat in said transverse direction, the inclination of the bottom wall portions being such as to position the bottom of said tongue below the lowermost part of the bottom wall portion.

3. The structure of claim 1 in which the top surface portions immediately adjacent said recess are of less downward inclination than the top surface portions adjacent said side surfaces to develop substantial bearing relation between said cap and adapter along the sides thereof.

4. A wear cap for an excavating tooth adapter, comprising a plate-like body having top, bottom, side and end walls,

5

- (A) said bottom wall being equipped with a centrally disposed, depending tongue extending parallel to said side walls, said tongue being of generally trapezoidal shape transverse of its length and being defined by uninterrupted side surfaces, with each side surface being inclined downwardly angularly relative to its adjacent side wall,
- (B) said bottom wall on each side of said tongue being downwardly transversely angularly inclined toward the adjacent side wall,
- (C) said top wall being inclined downwardly toward each end wall to develop a thicker intermediate section,
- (D) said tongue being adapted to be received in a similarly contoured recess in the adapter, with the forward and rear end surfaces of said tongue being parallel to provide bearing surfaces with a tooth point

8

10

15

6

and said adapter, respectively, to immobilize said cap.

5. The structure of claim 4 in which the included angle between opposite side portions of said bottom wall is of the order of 166°.

References Cited in the file of this patent

UNITED STATES PATENTS

1,008	Gregory	Nov. 14, 1838
1,168,469	Benson	Jan. 16, 1916
1,242,715	Nichols	Oct. 9, 1917
1,246,644	Nichols et al.	Nov. 13, 1917
2,896,345	Peklay	July 28, 1959

FOREIGN PATENTS

103,025	Great Britain	Jan. 11, 1917
139,456	Switzerland	July 16, 1930