



US 20080252005A1

(19) **United States**  
(12) **Patent Application Publication**  
**Pincus**

(10) **Pub. No.: US 2008/0252005 A1**  
(43) **Pub. Date: Oct. 16, 2008**

(54) **OBJECT HOLDING MECHANISM**

**Publication Classification**

(76) Inventor: **Jonathan Seth Pincus**, Marietta, GA (US)

(51) **Int. Cl.** *A63F 1/10* (2006.01)  
(52) **U.S. Cl.** ..... 273/150

Correspondence Address:  
**Hill, Kertscher & Wharton, LLP**  
**Suite 800, 3350 Riverwood Parkway**  
**Atlanta, GA 30339 (US)**

(57) **ABSTRACT**

An object connector for building a structure. The object connector is made of a light weight material with slots to hold various objects such as blocks and playing cards around the circumference of the connector as well as on the top and bottom of the connector. The top and bottom of the connector has a swiveling feature so the objects can be connected at a precise location.

(21) Appl. No.: **11/786,318**

(22) Filed: **Apr. 12, 2007**

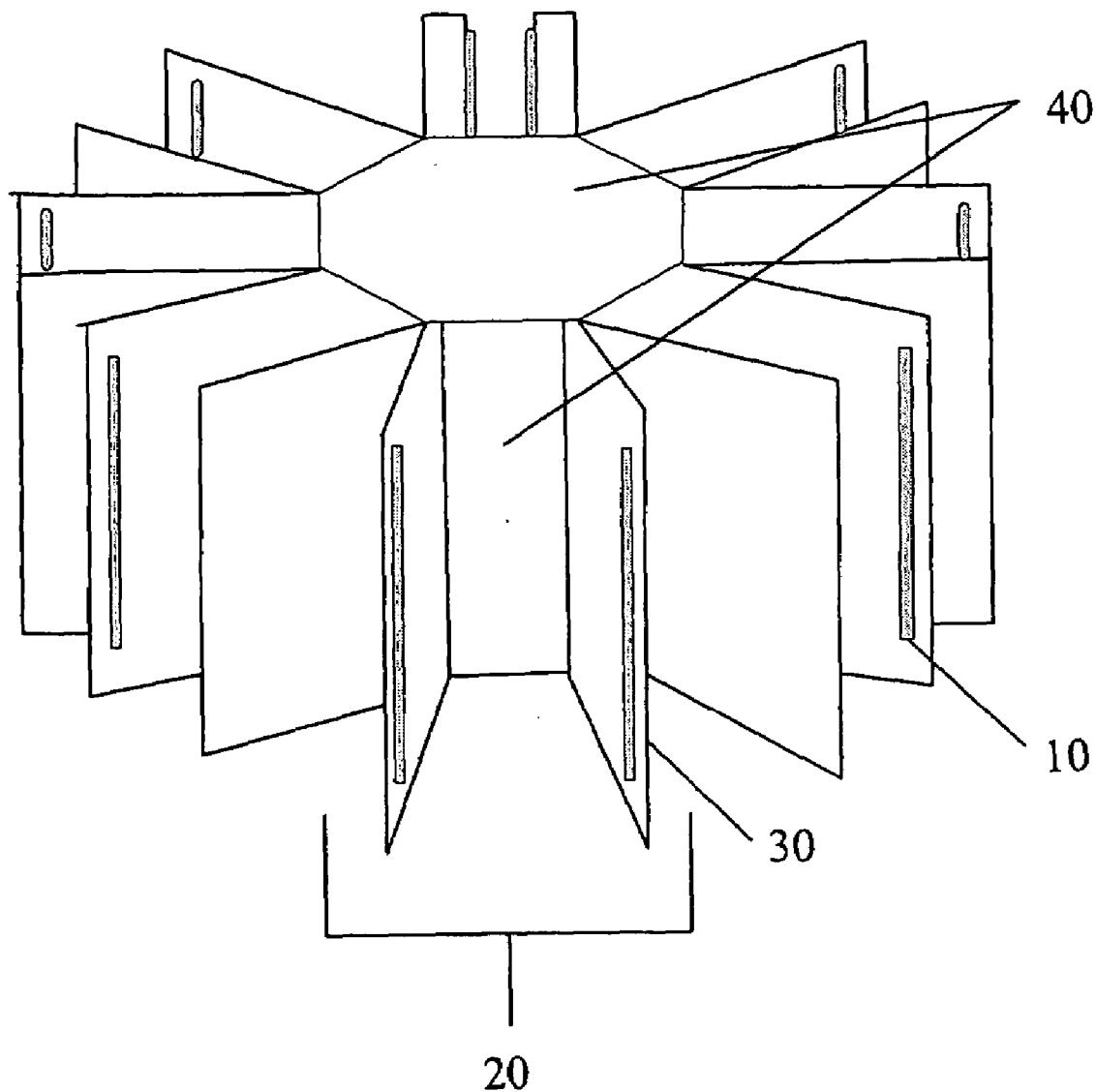

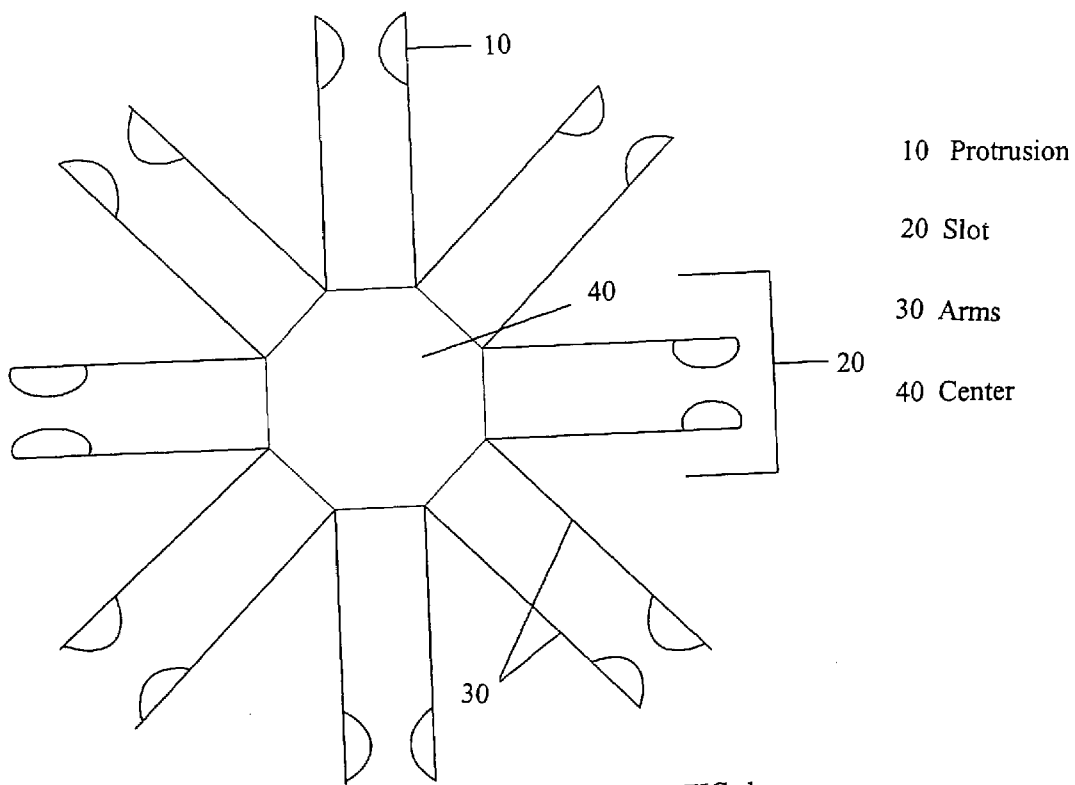

FIG. 1

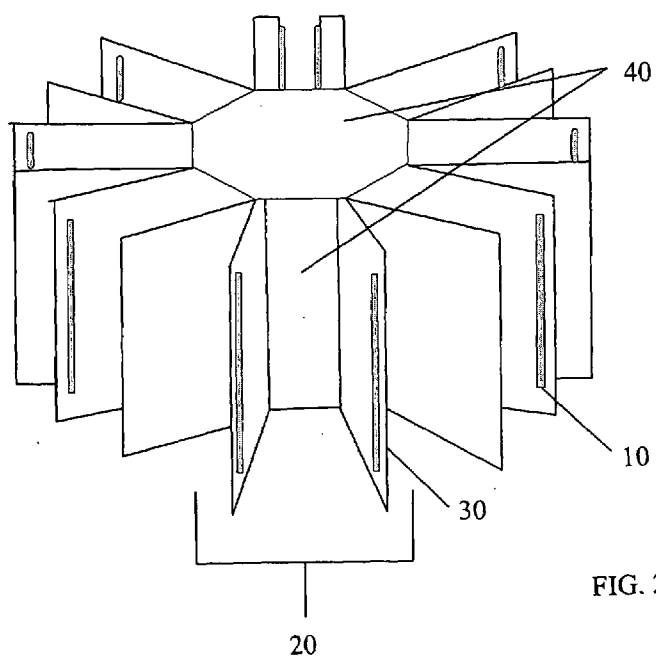

FIG. 2

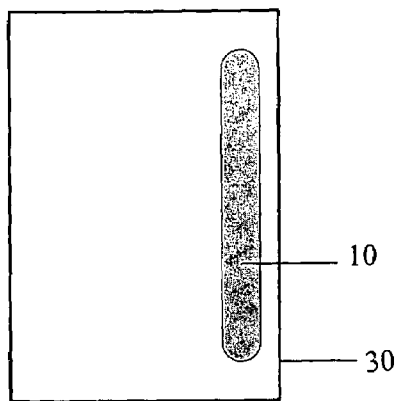
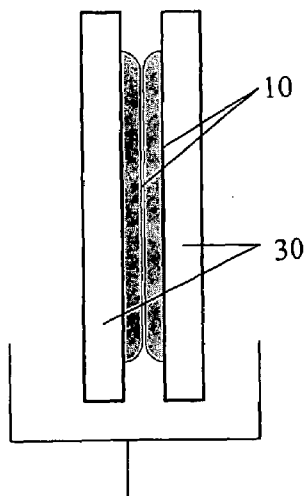

FIG. 3

10 Protrusion

20 Slot

30 Arms



20

FIG. 4

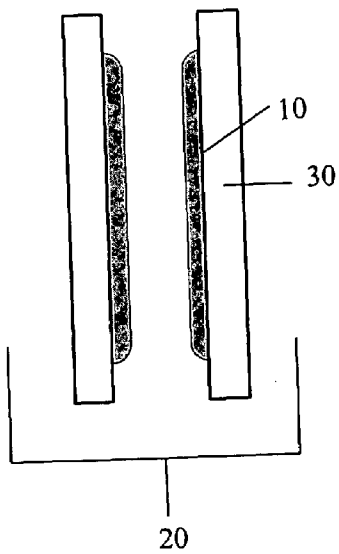

20

FIG. 5

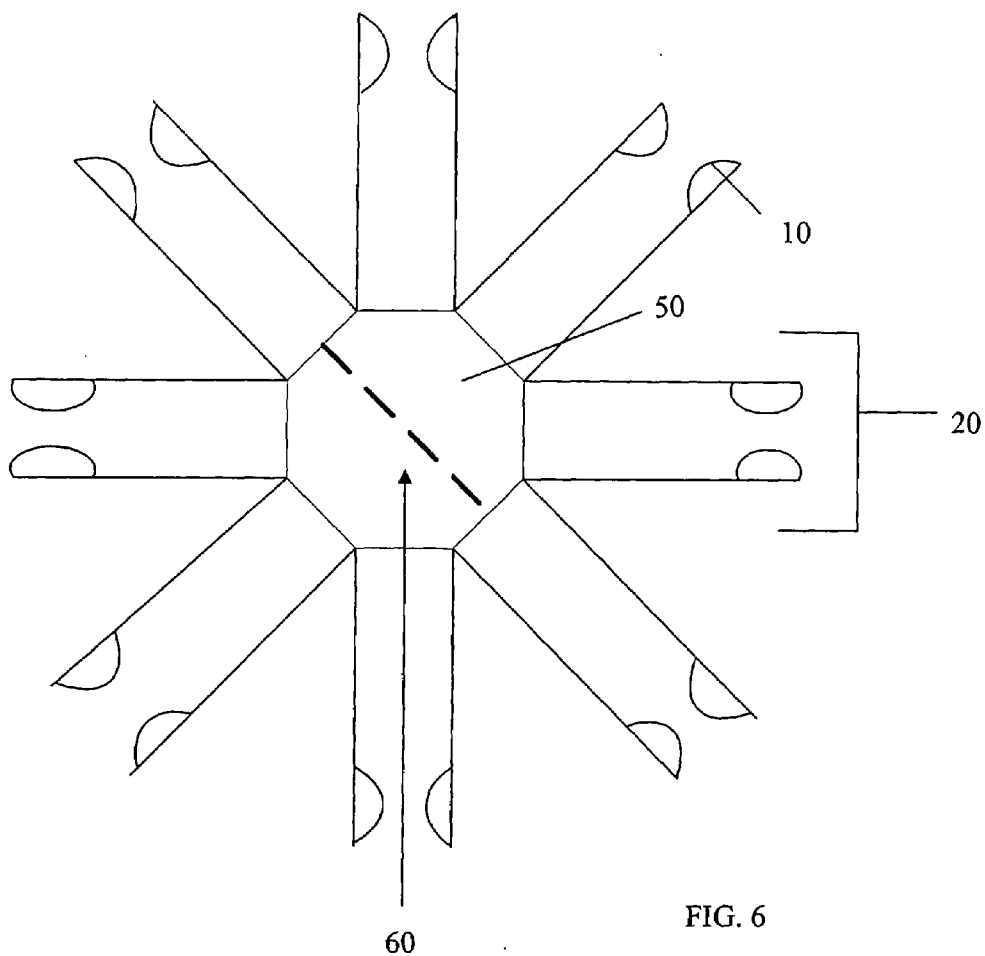

FIG. 6

10 Protrusion

20 Slot

50 Top

60 Swiveling Slot / Mechanism

**OBJECT HOLDING MECHANISM**

**CROSS REFERENCE TO RELATED APPLICATIONS**

[0001] Not Applicable

**STATEMENT REGARDING FEDERALLY SPONSORED RESEARCH OR DEVELOPMENT**

[0002] Not Applicable

**FIELD OF INVENTION**

[0003] The present invention relates to the field of strategic games and, in particular, to means for enabling different shaped objects to be held together to build a structure made of the objects. Specifically, the present invention relates to a mechanism that connects blocks or playing cards to one another to build a structure, which includes a house of cards or any other structure comprising two or more interconnected blocks. The present invention can be used for not only building structures but also design matching and strategic role playing.

**BACKGROUND OF THE INVENTION**

[0004] Blocks and playing cards are commonly used by individuals to build structures. Various sizes and shapes of connectors made out of wood, plastic, and metal have been used by individuals to connect items such as blocks and cards together.

[0005] Currently connectors exist to connect blocks and cards however the block and card connecting apparatuses that currently exist in the marketplace only have connecting mechanisms going around the connector and not on the top and bottom of the connector as well.

[0006] In the construction of structures, it is important that the connector holding the mechanism together be light enough so as not to weigh down the structure thereby limiting the height and width of the construction. Therefore, the need arises for the connector mechanism to be light weight.

[0007] Various attempts to solve the need for card holders and connectors are disclosed in U.S. Pat. No. 2,497,657 for "Construction Toy," U.S. Pat. No. 4,484,407 for "Connection Element for Assembling Toys," Des. 286,555 for "Card Clip," U.S. Pat. No. 5,050,793 for "System for Interconnecting Panels," U.S. Pat. No. 5,175,913 for "Connector for Use in Connecting Planar Objects," U.S. Pat. No. 5,238,438 for "Construction Toy and Adapter," U.S. Pat. No. 5,482,276 for "Playing Card Holder," U.S. Pat. No. 5,599,221 for "Connectors for Joining Construction Toy Joint Element and Brick," U.S. Pat. No. 5,725,411 for "Construction Beam Block Toy with Selective Angular Interlock," U.S. Pat. No. 5,961,365 for "Construction for a Modular Building Set," U.S. Pat. No. 6,572,429 for "Toy Model Building Set," U.S. Pat. No. 6,745,989 for "Card Holder," and U.S. Pat. No. 6,843,700 B2 for "Rod and Connector Toy Construction Set."

[0008] In the prior inventions, card holders and other forms of connectors are designed for cards and objects to fit in to slots around the circumference of the mechanisms. A card holder that holds more than one card has been designed but does not provide a way to hold cards on not only the circumference but also the top and bottom of the invention.

[0009] The present invention is distinguished over the prior art in general and these patents in particular by a slot to hold objects such as blocks and cards on all sides of the holder.

**SUMMARY OF THE INVENTION**

[0010] It is therefore an object of this invention to provide a connector with slots on the top and bottom of the connector as well as all the way around the circumference of the connector.

[0011] It is another object of this invention to provide a light weight connector which can be connected to multiple cards or blocks, but without weighting down the structure being built.

**BRIEF DESCRIPTION OF THE DRAWINGS**

[0012] Further objects of this invention, together with additional features contributing thereto, and advantages accruing there from, will be apparent from the following description of the preferred embodiment of the invention when read in conjunction with the accompanying drawings wherein:

[0013] FIG. 1 is an aerial view of the preferred embodiment.

[0014] FIG. 2 is a perspective view of the preferred embodiment.

[0015] FIG. 3 is a cross-sectional view of a section of the preferred embodiment.

[0016] FIG. 4 is a cross-sectional view of the preferred embodiment.

[0017] FIG. 5 is a cross-sectional view of the preferred embodiment.

[0018] FIG. 6 is an aerial view of the preferred embodiment.

**DETAILED DESCRIPTION OF THE DRAWINGS**

[0019] There is shown in FIG. 1, the aerial view of the object holding mechanism with eight slots 20 protruding from the center of the mechanism. Each slot 20 is rectangular in nature. Each slot 20 is composed of two arms 30 that are identical in nature. Each slot 20 has a protrusion 10 on the inner side of the slot 20 to hold an object, such as a block or a card, that is placed in the mechanism. Each slot 20 is attached to the center 40 of the mechanism and equidistant from one another. A person of ordinary skill in the art will recognize that the number of slots 20 on the mechanism may vary and the shape of the center 40 of the mechanism may vary depending on the number of slots 20.

[0020] As depicted in FIG. 2, each slot 20 is securely attached to the center 40 of the object holding mechanism for stability in securely holding the object that is placed within each slot 20. FIG. 2 displays the arms 30 of the slot 20 in a vertical perspective. In the preferred embodiment, the dimension of each arm 30 is approximately 2 inches in width and 3 inches in length. The thickness of each arm 20 is approximately 1/16 of an inch. However, it will be obvious to anyone of ordinary skill in the art that there are a variety of dimensions that can be used for the length, width and thickness of each arm 30. Two arms 30 are attached to the center 40 of the mechanism at a common point. Each pairing of arms 30 is connected to the center 40 of the mechanism in equidistance. In the preferred embodiment, the distance between each par-

ing of connected arms 20 is dependant on the number of arms 20 present on the mechanism. In FIG. 2, the preferred distance on the center 40 from one pair of arms 30 to the next pair of arms 30 is approximately 2 inches, but a person of ordinary skill in the art will recognize that there are a variety of distances that can be used.

[0021] FIG. 3 depicts one arm 30 with a larger view of the entire protrusion 10. The protrusion 10 on the preferred embodiment may be made of any material, such as a rubber strip, that is suitable for gripping the object, including a block or a playing card, into the slot 20. Although the protrusion 10 is described in terms of a particular embodiment known to the inventor, one of ordinary skill in the art will recognize that other protrusions 10 exist in the art, including the use of plastic strips and magnets to secure the object to the slot 20.

[0022] FIG. 4 depicts the slot 20 before an object has been placed in the slot 20.

[0023] FIG. 5 depicts the slot 20 in an expanded state as if an object is being placed in the slot 20.

[0024] FIG. 6 depicts the preferred embodiment from an aerial view. The top 50 of the center 40 has a swiveling slot 60 that rotates so an object, such as a block or a playing card, can be placed in it at the precise spot the builder chooses. The bottom of the preferred embodiment has the exact same swiveling mechanism 60 on it. For purposes of this written description, swiveling mechanisms are referred to as swiveling slots, and a person of ordinary skill in the art will recognize that there are a variety of swiveling mechanisms that can be used with the preferred embodiment described herein.

[0025] While the invention has been shown, described and illustrated in detail with reference to the preferred embodiment, and possible modifications thereof, it will be understood by those skilled in the art that equivalent changes in form and detail may be made therein without departing from the true spirit and scope of the invention as claimed.

I claim:

1. An apparatus for holding objects comprising;  
A center;

At least one slot extending from the center;

At least one slot on of the top and bottom of said center acting as a swivel; and

At least two protrusions for holding each object that is placed in between said slot.

2. The apparatus according to claim 1 wherein said slot is comprised of at least one pair of arms.

3. The apparatus according to claim 2 wherein at least one of said arms is rectangular in shape.

4. The apparatus according to claim 1 wherein said slot can expand and contract to hold said object that is being placed in between it.

5. The apparatus according to claim 1 wherein the inner side of said protrusions includes a plurality of rubber strips.

6. The apparatus according to claim 1 wherein at least one of said slots is equidistant from at least one other of said slots.

7. The unit according to claim 2 wherein at least one of said arms is connected to said center.

8. A method for using an apparatus for holding blocks, wherein the apparatus comprises at least a center, a slot extending from said center, at least two arms, at least two protrusions for holding a block placed on the inner surface of each arm, and at least one swiveled slot placed on the top and bottom of the center, the method comprising the steps of:

a. Placing the block in a slot;

b. Using a gripping material inside said at least one of said protrusions to hold the block between said arms.

c. Attaching a second apparatus for holding blocks to one of the three remaining sides of said block that is not already in a slot.

d. Placing a block in a second slot;

e. Building a structure.

8. The method of claim 8, wherein said gripping material is comprised of rubber.

\* \* \* \* \*