



- (51) International Patent Classification:  
*H02J 17/00* (2006.01)    *H02N 6/00* (2006.01)
- (21) International Application Number:  
PCT/US2012/060793
- (22) International Filing Date:  
18 October 2012 (18.10.2012)
- (25) Filing Language: English
- (26) Publication Language: English
- (30) Priority Data:  
61/548,521    18 October 2011 (18.10.2011)    US  
13/277,083    19 October 2011 (19.10.2011)    US
- (71) Applicant: **WITRICITY CORPORATION** [US/US];  
149 Grove Street, Watertown, MA 02472 (US).
- (72) Inventors: **LOU, Herbert, T.**; 84 Patch Meadow Lane,  
Carlisle, MA 01741 (US). **KESSLER, Morris, P.**; 95  
Hancock Street, Bedford, MA 01730 (US). **HALL, Kath-  
erine, L.**; 82 Cutter Hill Road, Arlington, MA 02474 (US).  
**GILER, Eric, R.**; 304 Marlborough Street, Boston, MA  
02116 (US). **KULIKOWSKI, Konrad, J.**; 45 High Street,  
Apartment 1, North Andover, MA 01845 (US). **CAM-  
PANELLA, Andrew, J.**; 39b Oak Street, Somerville, MA

02143 (US). **VERGHESE, Simon**; 5 Parker Road, Arling-  
ton, MA 02474 (US).

(74) Agent: **AMBROZIAK, Jeffrey**; GTC Law Group LLP &  
Affiliates, c/o CPA Global, P.O. Box 52050, Minneapolis,  
MN 55402 (US).

(81) Designated States (unless otherwise indicated, for every  
kind of national protection available): AE, AG, AL, AM,  
AO, AT, AU, AZ, BA, BB, BG, BH, BN, BR, BW, BY,  
BZ, CA, CH, CL, CN, CO, CR, CU, CZ, DE, DK, DM,  
DO, DZ, EC, EE, EG, ES, FI, GB, GD, GE, GH, GM, GT,  
HN, HR, HU, ID, IL, IN, IS, JP, KE, KG, KM, KN, KP,  
KR, KZ, LA, LC, LK, LR, LS, LT, LU, LY, MA, MD,  
ME, MG, MK, MN, MW, MX, MY, MZ, NA, NG, NI,  
NO, NZ, OM, PA, PE, PG, PH, PL, PT, QA, RO, RS, RU,  
RW, SC, SD, SE, SG, SK, SL, SM, ST, SV, SY, TH, TJ,  
TM, TN, TR, TT, TZ, UA, UG, US, UZ, VC, VN, ZA,  
ZM, ZW.

(84) Designated States (unless otherwise indicated, for every  
kind of regional protection available): ARIPO (BW, GH,  
GM, KE, LR, LS, MW, MZ, NA, RW, SD, SL, SZ, TZ,  
UG, ZM, ZW), Eurasian (AM, AZ, BY, KG, KZ, RU, TJ,  
TM), European (AL, AT, BE, BG, CH, CY, CZ, DE, DK,  
EE, ES, FI, FR, GB, GR, HR, HU, IE, IS, IT, LT, LU, LV,  
MC, MK, MT, NL, NO, PL, PT, RO, RS, SE, SI, SK, SM,

[Continued on next page]

(54) Title: WIRELESS ENERGY TRANSFER FOR PHOTOVOLTAIC PANELS

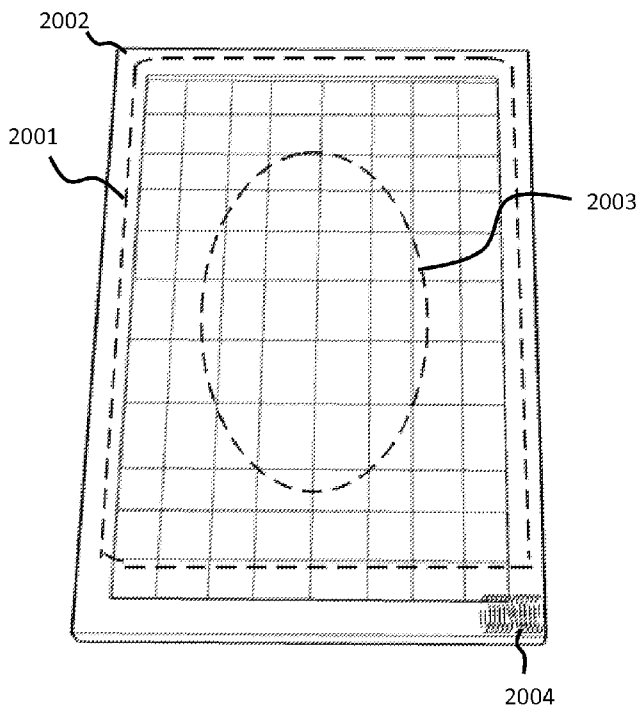

(57) Abstract: Described herein are improved configura-  
tions for a wireless power transfer involving photovoltaic  
panels. Described are methods and designs that use electric  
energy from a photovoltaic module to energize at least one  
wireless energy source to produce an oscillating magnetic  
field for wireless energy transfer. The source may be con-  
figured and tuned to present an impedance to a photovoltaic  
module wherein said impedance enables substantial extrac-  
tion of energy from said photovoltaic module.

WO 2013/059441 A1



---

TR), OAPI (BF, BJ, CF, CG, CI, CM, GA, GN, GQ, GW, ML, MR, NE, SN, TD, TG).

— *before the expiration of the time limit for amending the claims and to be republished in the event of receipt of amendments (Rule 48.2(h))*

**Published:**

— *with international search report (Art. 21(3))*

## WIRELESS ENERGY TRANSFER FOR PHOTOVOLTAIC PANELS

### CROSS-REFERENCE TO RELATED APPLICATIONS

[0001] This application claims the benefit of U.S. provisional patent application 61/548,521 filed October 18, 2011 and also to U.S. patent application 13/277,083, filed October 19, 2011.

[0002] The foregoing applications are incorporated herein by reference in their entirety.

### BACKGROUND

#### Field:

[0003] This disclosure relates to wireless energy transfer, methods, systems and apparatus to accomplish such transfer, and applications.

#### Description of the Related Art:

[0004] Energy or power may be transferred wirelessly using a variety of techniques as detailed, for example, in commonly owned U.S. Patent Application No. 12/789,611 published on September 23, 2010 as U.S. Pat. Pub. No. 2010/0237709 and entitled "RESONATOR ARRAYS FOR WIRELESS ENERGY TRANSFER," U.S. Patent Application No. 12/722,050 published on July 22, 2010 as U.S. Pat. Pub. No. 2010/0181843 and entitled "WIRELESS ENERGY TRANSFER FOR REFRIGERATOR APPLICATION," U.S. patent application 12/860,375 published on December 9, 2010 as 2010/0308939 and entitled "Integrated Resonator-Shield Structures," U.S. patent application 13/222,915 published on March 15, 2012 as 2012/0062345 and entitled "Low Resistance Electrical Conductor," U.S. patent application 13/283,811 published on \_\_\_\_\_ as \_\_\_\_\_ and entitled "Multi-Resonator Wireless Energy Transfer for Lighting," and U.S. patent application 13/534,966 published on \_\_\_\_\_ as \_\_\_\_\_, the contents of which are incorporated in their entirety as if fully set forth herein. Prior art wireless energy transfer systems have been limited by a variety of factors including concerns over user safety, low energy transfer efficiencies and restrictive physical proximity/alignment tolerances for the energy supply and sink components.

**[0005]** It is generally acknowledged that the adoption of traditional residential and commercial solar photovoltaic (PV) panel installations have been hampered by the high costs of these solar power systems. Recent estimates suggest that as much as 50% of the system costs are associated with the solar PV panel installation process. The factors driving the high cost of solar PV panel installations may include:

- **Roof Danger:** Installation work is generally performed on a roof, and such work may carry a substantial premium for Liability and Workman's Compensation Insurance due to the inherent danger.
- **Highly Skilled Labor:** The complexity of solar PV panel installation may require an ensemble of highly trained tradesmen (roofers, carpenters, and electricians), contractors, and professional engineers, who command premium rates.
- **Site-Specific Design:** Each installation may require site-specific engineering to optimize panel location, string design, and wiring configurations, to accommodate the individual roof pitch, solar orientation, and other building specific features. An installation comprising panels or strings with different illumination levels may need dedicated maximum power point tracker (MPPT) circuits to efficiently extract energy from the PV panels in those areas. The outputs of the MPPT circuits then need to be wired together or individually wired to an interior main inverter or battery charger. Without such site-specific optimization, output efficiency may be dramatically lower than expected.
- **Roof and Building Penetrations:** Running wiring through roof structures or exterior walls may be an expensive and potentially trouble prone operation, compromising the weather tightness of the building.
- **High Fixed Costs:** The installation costs may have a high fixed cost component, which means that the scale of the PV installation must be large enough (often 2kW-3kW) to amortize the installation costs. As a result, typical residential solar PV systems may cost upwards of \$20,000, and may have unsubsidized payback periods exceeding twenty (20) years.

**[0006]** In addition to high installation costs, traditional, wired, PV panels may be difficult to reconfigure and unreliable. These panels may need to be permanently wired into fixed locations making changes in configurations or repositioning troublesome since it may require rewiring and extending the electrical connections. In addition wired connections may make weatherproofing and sealing of the wires, connectors and circuit components in PV

systems more difficult and may result in more failure points in the installed systems which may be exposed to extreme environmental conditions including extreme temperatures, high winds, rain, high ultra violet radiation, and the like.

[0007] Therefore a need exists for methods and designs that reduce the cost and complexity associated with wiring of PV panels.

[0008] Energy distribution over an area to moving devices or devices that may be often repositioned is unpractical with wired connections. Moving and changing devices create the possibility of wire tangles, tripping hazards, and the like. Wireless energy transfer over a larger area may be difficult when the area or region in which devices may be present may be large compared to the size of the device. Large mismatches in a source and device wireless energy capture modules may pose challenges in delivering enough energy to the devices at a high enough efficiency to make the implementations practical or may be difficult to deploy.

[0009] Therefore a need exists for methods and designs for energy distribution that is wire free but easy to deploy and configurable while may deliver sufficient power to be practical to power many household and industrial devices.

## **SUMMARY**

[0010] Resonators and resonator assemblies may be positioned to distribute wireless energy over a larger area in packaging applications. The wireless energy transfer resonators and components that may be used have been described in, for example, in commonly owned U.S. Patent Application No. 12/789,611 published on September 23, 2010 as U.S. Pat. Pub. No. 2010/0237709 and entitled "RESONATOR ARRAYS FOR WIRELESS ENERGY TRANSFER," and U.S. Patent Application No. 12/722,050 published on July 22, 2010 as U.S. Pat. Pub. No. 2010/0181843 and entitled "WIRELESS ENERGY TRANSFER FOR REFRIGERATOR APPLICATION" the contents of which are incorporated in their entirety as if fully set forth herein.

[0011] In accordance with exemplary and non-limiting embodiments a packaged product comprises a product, a product packaging at least partially covering the product, a device resonator integrated with the product packaging for receiving wireless energy from a source resonator and an electrical component coupled to the device resonator to receive the wireless energy from the device resonator.

[0012] In accordance with another exemplary and non-limiting embodiment a method comprises providing at least one source resonator, providing a plurality of packaged products each comprising a device resonator for receiving wireless energy from the at least one source resonator and an electrical component coupled to the device resonator to receive the wireless energy from the device resonator and arranging the plurality of packaged products such that more than one of the plurality of packaged products is sufficiently close to the at least one source resonator to receive the wireless energy.

[0013] In accordance with another exemplary and non-limiting embodiment a system comprises at least one source resonator and a retaining device for positioning a plurality of packaged products each comprising a product, a product packaging at least partially covering the product, a device resonator integrated with the product packaging for receiving wireless energy from the source resonator and an electrical component coupled to the device resonator to receive the wireless energy from the device resonator.

[0014] Adding the capability to PV panels of wireless energy transfer using coupled resonators may substantially reduce the cost and complexity of the solar panel installation process. In embodiments, individual panels with associated MPPT circuits and associated wireless energy sources can be placed on a roof. Corresponding wireless energy capture devices may be located beneath the roof. Such a configuration may mitigate the factors driving the high cost of solar PV panel installations. For example, there may be less need for electrical wiring on the roof and for the associated roof penetrations. Fewer installation personnel may need to be trained and insured for roof-top work. And the PV panels might not need electrical feedthroughs and the associated weather seals.

[0015] One particular challenge in applying wireless energy transfer to PV panels is the problem of optimizing the wireless energy transfer without degrading the ability to extract maximum electrical energy from a PV panel or string of panels. The current and voltage characteristics of PV panels have a complex relationship that varies with the illumination level, PV panel temperature, and the electrical circuit connected to the PV panel. A conventional MPPT system samples the output of the PV panel and applies an equivalent load resistance that obtains the maximum power for any given environmental condition, including illumination and temperature. The problem is that the equivalent load resistance varies as environmental conditions change and the resistance at any given time may not be conducive to wireless energy transfer.

**[0016]** In one embodiment, for example, a PV panel may have a MPPT circuit that maximizes PV energy extraction but provides a varying current and voltage characteristic to a wireless energy source. Variations in the current or voltage at the input of a wireless energy source may degrade the efficiency of wireless energy transfer to a wireless energy capture device. In other embodiments, additional circuitry may be added to the MPPT circuit that regulates the output to the wireless energy source. The additional circuitry, however may absorb some of the energy intended for wireless transfer.

**[0017]** In another embodiment extraction of electrical energy from PV panels without losing substantial energy intended for wireless transfer is achieved with a wireless energy source that can be configured for energy transfer between resonators while also applying an equivalent load resistance to a PV panel for optimal energy extraction. Such a wireless source can efficiently transfer energy from a PV panel to a wireless capture device over a wider range of environmental conditions than is currently possible. Such a wireless energy source is referred to herein as a “wireless energy maximum power point tracker (WEMPPT).”

**[0018]** In embodiments, WEMPPT configuration may be realized in a wireless energy source comprising a switching amplifier by adding automatic adjustment of the switching times. In other embodiments, WEMPPT configuration may be realized in a wireless energy source comprising circuit elements such as capacitors, inductors, and resistors by adding automatic adjustment of said circuit elements in response to changing environmental conditions.

**[0019]** In addition to solar PV panels, other methods of generating electrical energy include wind-powered generators, water-powered generators, thermoelectric generators, and thermophotovoltaic generators. Such methods also provide electrical output that varies with environmental conditions, and conventional MPPT circuits can be used to maximize energy extraction. Those skilled in the art will understand that the features the WEMPPT configuration are general and may be applied to a wide range of electrical energy generators.

**[0020]** Various systems and processes, in various embodiments, provide wireless energy transfer using coupled resonators. In some embodiments, the wireless energy transfer system may require or benefit from a capability to verify and authenticate the source and the sink of the wireless energy. The features of such embodiments are general and may be applied to a wide range of resonators, regardless of the specific examples discussed herein.

**[0021]** In embodiments, a magnetic resonator may comprise some combination of inductors and capacitors. Additional circuit elements such as capacitors, inductors, resistors, switches, and the like, may be inserted between a magnetic resonator and a power source, and/or between a magnetic resonator and a power load. In this disclosure, the conducting coil that comprises the high-Q inductive loop of the resonator may be referred to as the inductor and/or the inductive load. The inductive load may also refer to the inductor when it is wirelessly coupled (through a mutual inductance) to other system or extraneous objects. In this disclosure, circuit elements other than the inductive load may be referred to as being part of an impedance matching network or IMN. It is to be understood that all, some, or none of the elements that are referred to as being part of an impedance matching network may be part of the magnetic resonator. Which elements are part of the resonator and which are separate from the resonator will depend on the specific magnetic resonator and wireless energy transfer system design.

**[0022]** In one aspect, a method of transferring energy from a photovoltaic device connected to a wireless energy source, may comprise configuring said source for energy transfer between resonators. At least one resonator may be connected to a wireless energy capture device. Said source may present an impedance to a photovoltaic device. Said impedance may enable substantial extraction of energy from said photovoltaic device. Impedance may be adjusted in response to a change in the irradiance on the photovoltaic device. One or more circuit parameters such as inductance, capacitance, resistance, or switching times may be adjusted in the wireless energy source. One or more circuit parameters such as inductance, capacitance, resistance, or switching times may be adjusted in the wireless energy capture device.

**[0023]** In another aspect, a method of transferring energy from a photovoltaic device connected to a wireless energy source, comprises configuring said source for energy transfer between resonators, where at least one resonator may be connected to a wireless energy capture device. Said capture device may output a current to a load. Said current may be controlled to a setpoint. Said source may present an impedance to a photovoltaic device. Said impedance may be adjusted in response to a change in the irradiance on the photovoltaic device. A plurality of wireless energy capture devices may have approximately the same setpoint and may be configured in series connection. The setpoint may be adjusted to maintain an expected voltage across the series connection.



**[0024]** In another aspect, a method of transferring energy from a photovoltaic device connected to a wireless energy source comprises configuring said source for energy transfer between resonators, where at least one resonator may be connected to a wireless energy capture device. Said capture device may output a voltage to a load. Said voltage may be controlled to a setpoint. Said source may present an impedance to a photovoltaic device. Impedance may be adjusted in response to a change in the irradiance on the photovoltaic device. A plurality of wireless energy capture devices may have approximately the same setpoint and may be configured in parallel connection. The setpoint may be adjusted to maintain an expected current across the parallel connection.

**[0025]** In another aspect, components of a wireless energy transfer system, wherein said system is connected to a photovoltaic device, have a secure out of band communication link for exchange of data and parameters as well as in-band signaling capability. The in-band signaling capability may be based on modifying or modulating the magnetic fields used for wireless power transfer. The in-band signaling capability may be used as a secondary communication channel to verify the source or the destination of the magnetic energy. The out-of-band signaling capability may be used for exchanging information for adjusting the parameters of energy transfer, monitoring the parameters of energy transfer, and comparing the expected and monitored changes to parameters of energy transfer.

**[0026]** Unless otherwise indicated, this disclosure uses the terms photovoltaic panel, photovoltaic module, photovoltaic device, solar panel, and the like, interchangeably. Those skilled in the art will understand that a variety of system architectures may be supported by the wide range of photovoltaic system designs and functionalities described in this application.

**[0027]** Unless otherwise indicated, this disclosure uses the terms wireless energy transfer, wireless power transfer, wireless power transmission, and the like, interchangeably. Those skilled in the art will understand that a variety of system architectures may be supported by the wide range of wireless system designs and functionalities described in this application.

**[0028]** In the wireless energy transfer systems described herein, power may be exchanged wirelessly between at least two resonators. Resonators may supply, receive, hold, transfer, and distribute energy. Sources of wireless power may be referred to as sources or supplies and receivers of wireless power may be referred to as devices, receivers and power loads. A resonator may be a source, a device, or both, simultaneously or may vary from one

function to another in a controlled manner. Resonators configured to hold or distribute energy that do not have wired connections to a power supply or power drain may be called repeaters.

**[0029]** The resonators of the wireless energy transfer systems of this invention are able to transfer power over distances that are large compared to the size of the resonators themselves. That is, if the resonator size is characterized by the radius of the smallest sphere that could enclose the resonator structure, the wireless energy transfer system of this invention can transfer power over distances greater than the characteristic size of a resonator. The system is able to exchange energy between resonators where the resonators have different characteristic sizes and where the inductive elements of the resonators have different sizes, different shapes, are comprised of different materials, and the like.

**[0030]** The wireless energy transfer systems of this invention may be described as having a coupling region, an energized area or volume, all by way of describing that energy may be transferred between resonant objects that are separated from each other, they may have variable distance from each other, and that may be moving relative to each other. In some embodiments, the area or volume over which energy can be transferred is referred to as the active field area or volume. In addition, the wireless energy transfer system may comprise more than two resonators that may each be coupled to a power source, a power load, both, or neither.

**[0031]** Wirelessly supplied energy may be used to power electric or electronic equipment, recharge batteries or charge energy storage units. Multiple devices may be charged or powered simultaneously or power delivery to multiple devices may be serialized such that one or more devices receive power for a period of time after which power delivery may be switched to other devices. In various embodiments, multiple devices may share power from one or more sources with one or more other devices either simultaneously, or in a time multiplexed manner, or in a frequency multiplexed manner, or in a spatially multiplexed manner, or in an orientation multiplexed manner, or in any combination of time and frequency and spatial and orientation multiplexing. Multiple devices may share power with each other, with at least one device being reconfigured continuously, intermittently, periodically, occasionally, or temporarily, to operate as a wireless power source. Those of ordinary skill in the art will understand that there are a variety of ways to power and/or charge devices applicable to the technologies and applications described herein.

**[0032]** This disclosure references certain individual circuit components and elements such as capacitors, inductors, resistors, diodes, transformers, switches and the like; combinations of these elements as networks, topologies, circuits, and the like; and objects that have inherent characteristics such as “self-resonant” objects with capacitance or inductance distributed (or partially distributed, as opposed to solely lumped) throughout the entire object. It would be understood by one of ordinary skill in the art that adjusting and controlling variable components within a circuit or network may adjust the performance of that circuit or network and that those adjustments may be described generally as tuning, adjusting, matching, correcting, and the like. Other methods to tune or adjust the operating point of the wireless power transfer system may be used alone, or in addition to adjusting tunable components such as inductors and capacitors, or banks of inductors and capacitors. Those skilled in the art will recognize that a particular topology discussed in this disclosure can be implemented in a variety of other ways.

**[0033]** Unless otherwise defined, all technical and scientific terms used herein have the same meaning as commonly understood by one of ordinary skill in the art to which this disclosure belongs. In case of conflict with publications, patent applications, patents, and other references mentioned or incorporated herein by reference, the present specification, including definitions, will control.

**[0034]** Unless otherwise indicated, this disclosure uses the terms wireless energy transfer, wireless power transfer, wireless power transmission, and the like, interchangeably. Those skilled in the art will understand that a variety of system architectures may be supported by the wide range of wireless system designs and functionalities described in this application.

**[0035]** This disclosure references certain individual circuit components and elements such as capacitors, inductors, resistors, diodes, transformers, switches and the like; combinations of these elements as networks, topologies, circuits, and the like; and objects that have inherent characteristics such as “self-resonant” objects with capacitance or inductance distributed (or partially distributed, as opposed to solely lumped) throughout the entire object. It would be understood by one of ordinary skill in the art that adjusting and controlling variable components within a circuit or network may adjust the performance of that circuit or network and that those adjustments may be described generally as tuning, adjusting, matching, correcting, and the like. Other methods to tune or adjust the operating point of the wireless power transfer system may be used alone, or in addition to adjusting

tunable components such as inductors and capacitors, or banks of inductors and capacitors. Those skilled in the art will recognize that a particular topology discussed in this disclosure can be implemented in a variety of other ways.

**[0036]** Unless otherwise defined, all technical and scientific terms used herein have the same meaning as commonly understood by one of ordinary skill in the art to which this disclosure belongs. In case of conflict with publications, patent applications, patents, and other references mentioned or incorporated herein by reference, the present specification, including definitions, will control.

**[0037]** Any of the features described above may be used, alone or in combination, without departing from the scope of this disclosure. Other features, objects, and advantages of the systems and methods disclosed herein will be apparent from the following detailed description and figures.

#### **BRIEF DESCRIPTION OF FIGURES**

**[0038]** Fig. 1 is a system block diagram of wireless energy transfer configurations.

**[0039]** Figs. 2A-2E are exemplary structures and schematics of simple resonator structures.

**[0040]** Fig. 3 is a block diagram of a wireless source with a single-ended amplifier.

**[0041]** Fig. 4 is a block diagram of a wireless source with a differential amplifier.

**[0042]** Figs. 5A and 5B are block diagrams of sensing circuits.

**[0043]** Figs. 6A, 6B, and 6C are block diagrams of a wireless source.

**[0044]** Fig. 7 is a plot showing the effects of a duty cycle on the parameters of an amplifier.

**[0045]** Fig. 8 is a simplified circuit diagram of a wireless power source with a switching amplifier.

**[0046]** Fig. 9 shows plots of the effects of changes of parameters of a wireless power source.

**[0047]** Fig. 10 shows plots of the effects of changes of parameters of a wireless power source.

**[0048]** Figs. 11A, 11B, 11C, and 11C are plots showing the effects of changes of parameters of a wireless power source.

- [0049] Fig. 12 shows plots of the effects of changes of parameters of a wireless power source.
- [0050] Fig. 13 is a simplified circuit diagram of a wireless energy transfer system comprising a wireless power source with a switching amplifier and a wireless power device.
- [0051] Fig. 14 shows plots of the effects of changes of parameters of a wireless power source.
- [0052] Fig. 15 is a diagram of a resonator showing possible non-uniform magnetic field distributions due to irregular spacing between tiles of magnetic material.
- [0053] Fig. 16 is a resonator with an arrangement of tiles in a block of magnetic material that may reduce hotspots in the magnetic material block.
- [0054] Fig. 17A is a resonator with a block of magnetic material comprising smaller individual tiles and 17B and 17C is the resonator with additional strips of thermally conductive material used for thermal management.
- [0055] Fig. 18 is a diagram of communication and energy transfer in a multisource system.
- [0056] Fig. 19A and Fig. 19B are diagrams showing a method for energy verification.
- [0057] Fig. 20 is a diagram of a solar PV panel with several integrated resonators.
- [0058] Fig. 21 is a diagram of a solar PV panel with an external resonator attached by a cable.
- [0059] Fig. 22 is a diagram of a vehicle with solar PV panels with wireless power transfer.
- [0060] Fig. 23 is a diagram of a sun umbrella with solar PV panels with wireless power resonators that can provide power to devices under the umbrella.
- [0061] Fig. 24 is a diagram of an embodiment of rooftop solar PV panels with wireless power transfer.
- [0062] Fig. 25 is a diagram of a rooftop solar PV panel system with independent resonators.
- [0063] Fig. 26 is a diagram of a rooftop solar PV panel system with wireless power transfer between panels.
- [0064] Fig. 27 is a diagram of a rooftop solar PV panel system with a connecting strip that wirelessly transfers power from several solar PV panels to one resonator.
- [0065] Fig. 28A shows a circuit model for a series of PV panels and Fig. 28B shows typical PV panel operating characteristics.

- [0066] Fig. 29 shows a plot of array voltage versus array current.
- [0067] Fig. 30 shows PV panel resistance and current characteristics.
- [0068] Figs. 31A-31C shows block diagrams of wireless energy transfer systems adapted for a PV panel.
- [0069] Fig. 32 is a diagram showing multiple outputs of panels combined together.
- [0070] Fig. 33 is diagram of a wireless energy transfer system with PV panels.
- [0071] Fig. 34 is diagram of an amplifier for wireless energy transfer system with PV panels.
- [0072] Fig. 35A and 35B shows voltage and current diagrams during operation of an amplifier.
- [0073] Fig. 36 shows characteristics of the impedance of the wireless source.
- [0074] Fig. 37A and 37B shows characteristics of the impedance of the wireless source.
- [0075] Fig. 38 shows a wireless energy transfer source with a PV cell.
- [0076] Fig. 39 shows a procedure for tuning the source for use with a PV panel.
- [0077] Fig. 40 shows a diagram of a wireless energy transfer system with a PV panels.
- [0078] Fig. 40 shows a diagram of a wireless energy transfer system with a PV panels.
- [0079] Fig. 41 shows a diagram of a wireless energy transfer system with a PV panels.
- [0080] Fig. 42 is diagram of a packaging enabled with wireless energy transfer.
- [0081] Fig. 43 is diagram of a packaging enabled with wireless energy transfer.
- [0082] Fig. 44 is diagram of a stack of packages enabled with wireless energy transfer.
- [0083] Fig. 45 is diagram of a packaging enabled with wireless energy transfer with a detuning patch.
- [0084] Fig. 46 is diagram of a packaging enabled with wireless energy transfer.

## **DETAILED DESCRIPTION**

[0085] As described above, this disclosure relates to wireless energy transfer using coupled electromagnetic resonators. However, such energy transfer is not restricted to electromagnetic resonators, and the wireless energy transfer systems described herein are

more general and may be implemented using a wide variety of resonators and resonant objects.

[0086] As those skilled in the art will recognize, important considerations for resonator-based power transfer include resonator efficiency and resonator coupling. Extensive discussion of such issues, e.g., coupled mode theory (CMT), coupling coefficients and factors, quality factors (also referred to as  $Q$ -factors), and impedance matching is provided, for example, in U.S. patent application 12/789,611 published on September 23, 2010 as US 20100237709 and entitled "RESONATOR ARRAYS FOR WIRELESS ENERGY TRANSFER," and U.S. patent application 12/722,050 published on July 22, 2010 as US 20100181843 and entitled "WIRELESS ENERGY TRANSFER FOR REFRIGERATOR APPLICATION" and incorporated herein by reference in its entirety as if fully set forth herein.

[0087] A resonator may be defined as a resonant structure that can store energy in at least two different forms, and where the stored energy oscillates between the two forms. The resonant structure will have a specific oscillation mode with a resonant (modal) frequency,  $f$ , and a resonant (modal) field. The angular resonant frequency,  $\omega$ , may be defined as  $\omega = 2\pi f$ , the resonant period,  $T$ , may be defined as  $T = 1/f = 2\pi/\omega$ , and the resonant wavelength,  $\lambda$ , may be defined as  $\lambda = c/f$ , where  $c$  is the speed of the associated field waves (light, for electromagnetic resonators). In the absence of loss mechanisms, coupling mechanisms or external energy supplying or draining mechanisms, the total amount of energy stored by the resonator,  $W$ , would stay fixed, but the form of the energy would oscillate between the two forms supported by the resonator, wherein one form would be maximum when the other is minimum and vice versa.

[0088] For example, a resonator may be constructed such that the two forms of stored energy are magnetic energy and electric energy. Further, the resonator may be constructed such that the electric energy stored by the electric field is primarily confined within the structure while the magnetic energy stored by the magnetic field is primarily in the region surrounding the resonator. In other words, the total electric and magnetic energies would be equal, but their localization would be different. Using such structures, energy exchange between at least two structures may be mediated by the resonant magnetic near-field of the at least two resonators. These types of resonators may be referred to as **magnetic resonators**.

[0089] An important parameter of resonators used in wireless power transmission systems is the **Quality Factor**, or  **$Q$ -factor**, or  **$Q$** , of the resonator, which characterizes the energy decay and is inversely proportional to energy losses of the resonator. It may be defined as  $Q = \omega * W / P$ , where  $P$  is the time-averaged power lost at steady state. That is, a resonator with a high- $Q$  has relatively low intrinsic losses and can store energy for a relatively long time. Since the resonator loses energy at its intrinsic decay rate,  $2\Gamma$ , its  $Q$ , also referred to as its intrinsic  $Q$ , is given by  $Q = \omega / 2\Gamma$ . The quality factor also represents the number of oscillation periods,  $T$ , it takes for the energy in the resonator to decay by a factor of  $e^{-2\pi}$ . Note that the quality factor or intrinsic quality factor or  $Q$  of the resonator is that due only to intrinsic loss mechanisms. The  $Q$  of a resonator connected to, or coupled to a power generator,  $g$ , or load,  $l$ , may be called the “**loaded quality factor**” or the “loaded  $Q$ ”. The  $Q$  of a resonator in the presence of an extraneous object that is not intended to be part of the energy transfer system may be called the “**perturbed quality factor**” or the “perturbed  $Q$ ”.

[0090] Resonators, coupled through any portion of their near-fields may interact and exchange energy. The efficiency of this energy transfer can be significantly enhanced if the resonators operate at substantially the same resonant frequency. By way of example, but not limitation, imagine a source resonator with  $Q_s$  and a device resonator with  $Q_d$ . High- $Q$  wireless energy transfer systems may utilize resonators that are high- $Q$ . The  $Q$  of each resonator may be high. The geometric mean of the resonator  $Q$ 's,  $\sqrt{Q_s Q_d}$  may also or instead be high.

[0091] The **coupling factor**,  $k$ , is a number between  $0 \leq |k| \leq 1$ , and it may be independent (or nearly independent) of the resonant frequencies of the source and device resonators, when those are placed at sub-wavelength distances. Rather the coupling factor  $k$  may be determined mostly by the relative geometry and the distance between the source and device resonators where the physical decay-law of the field mediating their coupling is taken into account. The coupling coefficient used in CMT,  $\kappa = k \sqrt{\omega_s \omega_d} / 2$ , may be a strong function of the resonant frequencies, as well as other properties of the resonator structures. In applications for wireless energy transfer utilizing the near-fields of the resonators, it is



desirable to have the size of the resonator be much smaller than the resonant wavelength, so that power lost by radiation is reduced. In some embodiments, high-Q resonators are sub-wavelength structures. In some electromagnetic embodiments, high-Q resonator structures are designed to have resonant frequencies higher than 100 kHz. In other embodiments, the resonant frequencies may be less than 1 GHz.

**[0092]** In exemplary embodiments, the power radiated into the far-field by these sub-wavelength resonators may be further reduced by lowering the resonant frequency of the resonators and the operating frequency of the system. In other embodiments, the far field radiation may be reduced by arranging for the far fields of two or more resonators to interfere destructively in the far field.

**[0093]** In a wireless energy transfer system a resonator may be used as a wireless energy source, a wireless energy capture device, a repeater or a combination thereof. In embodiments a resonator may alternate between transferring energy, receiving energy or relaying energy. In a wireless energy transfer system one or more magnetic resonators may be coupled to an energy source and be energized to produce an oscillating magnetic near-field. Other resonators that are within the oscillating magnetic near-fields may capture these fields and convert the energy into electrical energy that may be used to power or charge a load thereby enabling wireless transfer of useful energy.

**[0094]** The so-called “useful” energy in a useful energy exchange is the energy or power that must be delivered to a device in order to power or charge it at an acceptable rate. The transfer efficiency that corresponds to a useful energy exchange may be system or application-dependent. For example, high power vehicle charging applications that transfer kilowatts of power may need to be at least 80% efficient in order to supply useful amounts of power resulting in a useful energy exchange sufficient to recharge a vehicle battery without significantly heating up various components of the transfer system. In some consumer electronics applications, a useful energy exchange may include any energy transfer efficiencies greater than 10%, or any other amount acceptable to keep rechargeable batteries “topped off” and running for long periods of time. In implanted medical device applications, a useful energy exchange may be any exchange that does not harm the patient but that extends the life of a battery or wakes up a sensor or monitor or stimulator. In such applications, 100 mW of power or less may be useful. In distributed sensing applications, power transfer of microwatts may be useful, and transfer efficiencies may be well below 1%.

[0095] A useful energy exchange for wireless energy transfer in a powering or recharging application may be efficient, highly efficient, or efficient enough, as long as the wasted energy levels, heat dissipation, and associated field strengths are within tolerable limits and are balanced appropriately with related factors such as cost, weight, size, and the like.

[0096] The resonators may be referred to as source resonators, device resonators, first resonators, second resonators, repeater resonators, and the like. Implementations may include three (3) or more resonators. For example, a single source resonator may transfer energy to multiple device resonators or multiple devices. Energy may be transferred from a first device to a second, and then from the second device to the third, and so forth. Multiple sources may transfer energy to a single device or to multiple devices connected to a single device resonator or to multiple devices connected to multiple device resonators. Resonators may serve alternately or simultaneously as sources, devices, and/or they may be used to relay power from a source in one location to a device in another location. Intermediate electromagnetic resonators may be used to extend the distance range of wireless energy transfer systems and/or to generate areas of concentrated magnetic near-fields. Multiple resonators may be daisy-chained together, exchanging energy over extended distances and with a wide range of sources and devices. For example, a source resonator may transfer power to a device resonator via several repeater resonators. Energy from a source may be transferred to a first repeater resonator, the first repeater resonator may transfer the power to a second repeater resonator and the second to a third and so on until the final repeater resonator transfers its energy to a device resonator. In this respect the range or distance of wireless energy transfer may be extended and/or tailored by adding repeater resonators. High power levels may be split between multiple sources, transferred to multiple devices and recombined at a distant location.

[0097] The resonators may be designed using coupled mode theory models, circuit models, electromagnetic field models, and the like. The resonators may be designed to have tunable characteristic sizes. The resonators may be designed to handle different power levels. In exemplary embodiments, high power resonators may require larger conductors and higher current or voltage rated components than lower power resonators.

[0098] Fig. 1 shows a diagram of exemplary configurations and arrangements of a wireless energy transfer system. A wireless energy transfer system may include at least one source resonator (R1) **104** (optionally R6, **112**) coupled to an energy source **102** and

optionally a sensor and control unit **108**. The energy source may be a source of any type of energy capable of being converted into electrical energy that may be used to drive the source resonator **104**. The energy source may be a battery, a solar panel, the electrical mains, a wind or water turbine, an electromagnetic resonator, a generator, and the like. The electrical energy used to drive the magnetic resonator is converted into oscillating magnetic fields by the resonator. The oscillating magnetic fields may be captured by other resonators which may be device resonators (R2) **106**, (R3) **116** that are optionally coupled to an energy drain **110**. The oscillating fields may be optionally coupled to repeater resonators (R4, R5) that are configured to extend or tailor the wireless energy transfer region. Device resonators may capture the magnetic fields in the vicinity of source resonator(s), repeater resonators and other device resonators and convert them into electrical energy that may be used by an energy drain. The energy drain **110** may be an electrical, electronic, mechanical or chemical device and the like configured to receive electrical energy. Repeater resonators may capture magnetic fields in the vicinity of source, device and repeater resonator(s) and may pass the energy on to other resonators.

**[0099]** A wireless energy transfer system may comprise a single source resonator **104** coupled to an energy source **102** and a single device resonator **106** coupled to an energy drain **110**. In embodiments a wireless energy transfer system may comprise multiple source resonators coupled to one or more energy sources and may comprise multiple device resonators coupled to one or more energy drains.

**[00100]** In embodiments the energy may be transferred directly between a source resonator **104** and a device resonator **106**. In other embodiments the energy may be transferred from one or more source resonators **104, 112** to one or more device resonators **106, 116** via any number of intermediate resonators which may be device resonators, source resonators, repeater resonators, and the like. Energy may be transferred via a network or arrangement of resonators **114** that may include subnetworks **118, 120** arranged in any combination of topologies such as token ring, mesh, ad hoc, and the like.

**[00101]** In embodiments the wireless energy transfer system may comprise a centralized sensing and control system **108**. In embodiments parameters of the resonators, energy sources, energy drains, network topologies, operating parameters, etc. may be monitored and adjusted from a control processor to meet specific operating parameters of the system. A central control processor may adjust parameters of individual components of the system to optimize global energy transfer efficiency, to optimize the amount of power

transferred, and the like. Other embodiments may be designed to have a substantially distributed sensing and control system. Sensing and control may be incorporated into each resonator or group of resonators, energy sources, energy drains, and the like and may be configured to adjust the parameters of the individual components in the group to maximize the power delivered, to maximize energy transfer efficiency in that group and the like.

**[00102]** In embodiments, components of the wireless energy transfer system may have wireless or wired data communication links to other components such as devices, sources, repeaters, power sources, resonators, and the like and may transmit or receive data that can be used to enable the distributed or centralized sensing and control. A wireless communication channel may be separate from the wireless energy transfer channel, or it may be the same. In one embodiment the resonators used for power exchange may also be used to exchange information. In some cases, information may be exchanged by modulating a component in a source or device circuit and sensing that change with port parameter or other monitoring equipment. Resonators may signal each other by tuning, changing, varying, dithering, and the like, the resonator parameters such as the impedance of the resonators which may affect the reflected impedance of other resonators in the system. The systems and methods described herein may enable the simultaneous transmission of power and communication signals between resonators in wireless power transmission systems, or it may enable the transmission of power and communication signals during different time periods or at different frequencies using the same magnetic fields that are used during the wireless energy transfer. In other embodiments wireless communication may be enabled with a separate wireless communication channel such as WiFi, Bluetooth, Infrared, and the like.

**[00103]** In embodiments, a wireless energy transfer system may include multiple resonators and overall system performance may be improved by control of various elements in the system. For example, devices with lower power requirements may tune their resonant frequency away from the resonant frequency of a high-power source that supplies power to devices with higher power requirements. In this way, low and high power devices may safely operate or charge from a single high power source. In addition, multiple devices in a charging zone may find the power available to them regulated according to any of a variety of consumption control algorithms such as First-Come-First-Serve, Best Effort, Guaranteed Power, etc. The power consumption algorithms may be hierarchical in nature, giving priority to certain users or types of devices, or it may support any number of users by equally sharing

the power that is available in the source. Power may be shared by any of the multiplexing techniques described in this disclosure.

**[00104]** In embodiments electromagnetic resonators may be realized or implemented using a combination of shapes, structures, and configurations. Electromagnetic resonators may include an inductive element, a distributed inductance, or a combination of inductances with a total inductance,  $L$ , and a capacitive element, a distributed capacitance, or a combination of capacitances, with a total capacitance,  $C$ . A minimal circuit model of an electromagnetic resonator comprising capacitance, inductance and resistance, is shown in Fig. 2F. The resonator may include an inductive element **238** and a capacitive element **240**. Provided with initial energy, such as electric field energy stored in the capacitor **240**, the system will oscillate as the capacitor discharges transferring energy into magnetic field energy stored in the inductor **238** which in turn transfers energy back into electric field energy stored in the capacitor **240**. Intrinsic losses in these electromagnetic resonators include losses due to resistance in the inductive and capacitive elements and to radiation losses, and are represented by the resistor,  $R$ , **242** in Fig. 2F.

**[00105]** Fig. 2A shows a simplified drawing of an exemplary magnetic resonator structure. The magnetic resonator may include a loop of conductor acting as an inductive element **202** and a capacitive element **204** at the ends of the conductor loop. The inductor **202** and capacitor **204** of an electromagnetic resonator may be bulk circuit elements, or the inductance and capacitance may be distributed and may result from the way the conductors are formed, shaped, or positioned, in the structure.

**[00106]** For example, the inductor **202** may be realized by shaping a conductor to enclose a surface area, as shown in Figs. 2A. This type of resonator may be referred to as a capacitively-loaded loop inductor. Note that we may use the terms “loop” or “coil” to indicate generally a conducting structure (wire, tube, strip, etc.), enclosing a surface of any shape and dimension, with any number of turns. In Fig. 2A, the enclosed surface area is circular, but the surface may be any of a wide variety of other shapes and sizes and may be designed to achieve certain system performance specifications. In embodiments the inductance may be realized using inductor elements, distributed inductance, networks, arrays, series and parallel combinations of inductors and inductances, and the like. The inductance may be fixed or variable and may be used to vary impedance matching as well as resonant frequency operating conditions.

[00107] There are a variety of ways to realize the capacitance required to achieve the desired resonant frequency for a resonator structure. Capacitor plates **204** may be formed and utilized as shown in Fig. 2A, or the capacitance may be distributed and be realized between adjacent windings of a multi-loop conductor. The capacitance may be realized using capacitor elements, distributed capacitance, networks, arrays, series and parallel combinations of capacitances, and the like. The capacitance may be fixed or variable and may be used to vary impedance matching as well as resonant frequency operating conditions.

[00108] The inductive elements used in magnetic resonators may contain more than one loop and may spiral inward or outward or up or down or in some combination of directions. In general, the magnetic resonators may have a variety of shapes, sizes and number of turns and they may be composed of a variety of conducting materials. The conductor **210**, for example, may be a wire, a Litz wire, a ribbon, a pipe, a trace formed from conducting ink, paint, gels, and the like or from single or multiple traces printed on a circuit board. An exemplary embodiment of a trace pattern on a substrate **208** forming inductive loops is depicted in Fig. 2B.

[00109] In embodiments the inductive elements may be formed using magnetic materials of any size, shape thickness, and the like, and of materials with a wide range of permeability and loss values. These magnetic materials may be solid blocks, they may enclose hollow volumes, they may be formed from many smaller pieces of magnetic material tiled and or stacked together, and they may be integrated with conducting sheets or enclosures made from highly conducting materials. Conductors may be wrapped around the magnetic materials to generate the magnetic field. These conductors may be wrapped around one or more than one axis of the structure. Multiple conductors may be wrapped around the magnetic materials and combined in parallel, or in series, or via a switch to form customized near-field patterns and/or to orient the dipole moment of the structure. Examples of resonators comprising magnetic material are depicted in Figures 2C, 2D, 2E. In Fig. 2D the resonator comprises loops of conductor **224** wrapped around a core of magnetic material **222** creating a structure that has a magnetic dipole moment **228** that is parallel to the axis of the loops of the conductor **224**. The resonator may comprise multiple loops of conductor **216**, **212** wrapped in orthogonal directions around the magnetic material **214** forming a resonator with a magnetic dipole moment **218**, **220** that may be oriented in more than one direction as depicted in Fig. 2C, depending on how the conductors are driven.

**[00110]** An electromagnetic resonator may have a characteristic, natural, or resonant frequency determined by its physical properties. This resonant frequency is the frequency at which the energy stored by the resonator oscillates between that stored by the electric field,  $W_E$ , ( $W_E = q^2/2C$ , where  $q$  is the charge on the capacitor,  $C$ ) and that stored by the magnetic field,  $W_B$ , ( $W_B = Li^2/2$ , where  $i$  is the current through the inductor,  $L$ ) of the resonator. The frequency at which this energy is exchanged may be called the characteristic frequency, the natural frequency, or the resonant frequency of the resonator, and is given by  $\omega$ ,

$$\omega = 2\pi f = \sqrt{\frac{1}{LC}}.$$

The resonant frequency of the resonator may be changed by tuning the inductance,  $L$ , and/or the capacitance,  $C$ , of the resonator. In one embodiment system parameters are dynamically adjustable or tunable to achieve as close as possible to optimal operating conditions.

However, based on the discussion above, efficient enough energy exchange may be realized even if some system parameters are not variable or components are not capable of dynamic adjustment.

**[00111]** In embodiments a resonator may comprise an inductive element coupled to more than one capacitor arranged in a network of capacitors and circuit elements. In embodiments the coupled network of capacitors and circuit elements may be used to define more than one resonant frequency of the resonator. In embodiments a resonator may be resonant, or partially resonant, at more than one frequency.

**[00112]** In embodiments, a wireless power source may comprise of at least one resonator coil coupled to a power supply, which may be a switching amplifier, such as a class-D amplifier or a class-E amplifier or a combination thereof. In this case, the resonator coil is effectively a power load to the power supply. In embodiments, a wireless power device may comprise of at least one resonator coil coupled to a power load, which may be a switching rectifier, such as a class-D rectifier or a class-E rectifier or a combination thereof. In this case, the resonator coil is effectively a power supply for the power load, and the impedance of the load directly relates also to the work-drainage rate of the load from the resonator coil. The efficiency of power transmission between a power supply and a power load may be impacted by how closely matched the output impedance of the power source is to the input impedance of the load. Power may be delivered to the load at a maximum

possible efficiency, when the input impedance of the load is equal to the complex conjugate of the internal impedance of the power supply. Designing the power supply or power load impedance to obtain a maximum power transmission efficiency is often called "impedance matching", and may also referred to as optimizing the ratio of useful-to-lost powers in the system. Impedance matching may be performed by adding networks or sets of elements such as capacitors, inductors, transformers, switches, resistors, and the like, to form impedance matching networks between a power supply and a power load. In embodiments, mechanical adjustments and changes in element positioning may be used to achieve impedance matching. For varying loads, the impedance matching network may include variable components that are dynamically adjusted to ensure that the impedance at the power supply terminals looking towards the load and the characteristic impedance of the power supply remain substantially complex conjugates of each other, even in dynamic environments and operating scenarios.

**[00113]** In embodiments, impedance matching may be accomplished by tuning the duty cycle, and/or the phase, and/or the frequency of the driving signal of the power supply or by tuning a physical component within the power supply, such as a capacitor. Such a tuning mechanism may be advantageous because it may allow impedance matching between a power supply and a load without the use of a tunable impedance matching network, or with a simplified tunable impedance matching network, such as one that has fewer tunable components for example. In embodiments, tuning the duty cycle, and/or frequency, and/or phase of the driving signal to a power supply may yield a dynamic impedance matching system with an extended tuning range or precision, with higher power, voltage and/or current capabilities, with faster electronic control, with fewer external components, and the like.

**[00114]** In some wireless energy transfer systems the parameters of the resonator such as the inductance may be affected by environmental conditions such as surrounding objects, temperature, orientation, number and position of other resonators and the like. Changes in operating parameters of the resonators may change certain system parameters, such as the efficiency of transferred power in the wireless energy transfer. For example, high-conductivity materials located near a resonator may shift the resonant frequency of a resonator and detune it from other resonant objects. In some embodiments, a resonator feedback mechanism is employed that corrects its frequency by changing a reactive element (e.g., an inductive element or capacitive element). In order to achieve acceptable matching conditions, at least some of the system parameters may need to be dynamically adjustable or tunable. All the system parameters may be dynamically adjustable or tunable to achieve



approximately the optimal operating conditions. However, efficient enough energy exchange may be realized even if all or some system parameters are not variable. In some examples, at least some of the devices may not be dynamically adjusted. In some examples, at least some of the sources may not be dynamically adjusted. In some examples, at least some of the intermediate resonators may not be dynamically adjusted. In some examples, none of the system parameters may be dynamically adjusted.

**[00115]** In some embodiments changes in parameters of components may be mitigated by selecting components with characteristics that change in a complimentary or opposite way or direction when subjected to differences in operating environment or operating point. In embodiments, a system may be designed with components, such as capacitors, that have an opposite dependence or parameter fluctuation due to temperature, power levels, frequency, and the like. In some embodiments, the component values as a function of temperature may be stored in a look-up table in a system microcontroller and the reading from a temperature sensor may be used in the system control feedback loop to adjust other parameters to compensate for the temperature induced component value changes.

**[00116]** In some embodiments the changes in parameter values of components may be compensated with active tuning circuits comprising tunable components. Circuits that monitor the operating environment and operating point of components and system may be integrated in the design. The monitoring circuits may provide the signals necessary to actively compensate for changes in parameters of components. For example, a temperature reading may be used to calculate expected changes in, or to indicate previously measured values of, capacitance of the system allowing compensation by switching in other capacitors or tuning capacitors to maintain the desired capacitance over a range of temperatures. In embodiments, the RF amplifier switching waveforms may be adjusted to compensate for component value or load changes in the system. In some embodiments the changes in parameters of components may be compensated with active cooling, heating, active environment conditioning, and the like.

**[00117]** The parameter measurement circuitry may measure or monitor certain power, voltage, and current, signals in the system, and processors or control circuits may adjust certain settings or operating parameters based on those measurements. In addition the magnitude and phase of voltage and current signals, and the magnitude of the power signals, throughout the system may be accessed to measure or monitor the system performance. The measured signals referred to throughout this disclosure may be any combination of port

parameter signals, as well as voltage signals, current signals, power signals, temperatures signals and the like. These parameters may be measured using analog or digital techniques, they may be sampled and processed, and they may be digitized or converted using a number of known analog and digital processing techniques. In embodiments, preset values of certain measured quantities are loaded in a system controller or memory location and used in various feedback and control loops. In embodiments, any combination of measured, monitored, and/or preset signals may be used in feedback circuits or systems to control the operation of the resonators and/or the system.

**[00118]** Adjustment algorithms may be used to adjust the frequency, Q, and/or impedance of the magnetic resonators. The algorithms may take as inputs reference signals related to the degree of deviation from a desired operating point for the system and may output correction or control signals related to that deviation that control variable or tunable elements of the system to bring the system back towards the desired operating point or points. The reference signals for the magnetic resonators may be acquired while the resonators are exchanging power in a wireless power transmission system, or they may be switched out of the circuit during system operation. Corrections to the system may be applied or performed continuously, periodically, upon a threshold crossing, digitally, using analog methods, and the like.

**[00119]** In embodiments, lossy extraneous materials and objects may introduce potential reductions in efficiencies by absorbing the magnetic and/or electric energy of the resonators of the wireless power transmission system. Those impacts may be mitigated in various embodiments by positioning resonators to minimize the effects of the lossy extraneous materials and objects and by placing structural field shaping elements (e.g., conductive structures, plates and sheets, magnetic material structures, plates and sheets, and combinations thereof) to minimize their effect.

**[00120]** One way to reduce the impact of lossy materials on a resonator is to use high-conductivity materials, magnetic materials, or combinations thereof to shape the resonator fields such that they avoid the lossy objects. In an exemplary embodiment, a layered structure of high-conductivity material and magnetic material may tailor, shape, direct, reorient, etc. the resonator's electromagnetic fields so that they avoid lossy objects in their vicinity by deflecting the fields. Fig. 2D shows a top view of a resonator with a sheet of conductor **226** below the magnetic material that may be used to tailor the fields of the resonator so that they avoid lossy objects that may be below the sheet of conductor **226**. The layer or sheet of good

226 conductor may comprise any high conductivity materials such as copper, silver, aluminum, as may be most appropriate for a given application. In certain embodiments, the layer or sheet of good conductor is thicker than the skin depth of the conductor at the resonator operating frequency. The conductor sheet may be preferably larger than the size of the resonator, extending beyond the physical extent of the resonator.

[00121] In environments and systems where the amount of power being transmitted could present a safety hazard to a person or animal that may intrude into the active field volume, safety measures may be included in the system. In embodiments where power levels require particularized safety measures, the packaging, structure, materials, and the like of the resonators may be designed to provide a spacing or “keep away” zone from the conducting loops in the magnetic resonator. To provide further protection, high-  $Q$  resonators and power and control circuitry may be located in enclosures that confine high voltages or currents to within the enclosure, that protect the resonators and electrical components from weather, moisture, sand, dust, and other external elements, as well as from impacts, vibrations, scrapes, explosions, and other types of mechanical shock . Such enclosures call for attention to various factors such as thermal dissipation to maintain an acceptable operating temperature range for the electrical components and the resonator. In embodiments, enclosure may be constructed of non-lossy materials such as composites, plastics, wood, concrete, and the like and may be used to provide a minimum distance from lossy objects to the resonator components. A minimum separation distance from lossy objects or environments which may include metal objects, salt water, oil and the like, may improve the efficiency of wireless energy transfer. In embodiments, a “keep away” zone may be used to increase the perturbed  $Q$  of a resonator or system of resonators. In embodiments a minimum separation distance may provide for a more reliable or more constant operating parameters of the resonators.

[00122] In embodiments, resonators and their respective sensor and control circuitry may have various levels of integration with other electronic and control systems and subsystems. In some embodiments the power and control circuitry and the device resonators are completely separate modules or enclosures with minimal integration to existing systems, providing a power output and a control and diagnostics interface. In some embodiments a device is configured to house a resonator and circuit assembly in a cavity inside the enclosure, or integrated into the housing or enclosure of the device.

[00123] **Example Resonator Circuitry**

[00124] Figures 3 and 4 show high level block diagrams depicting power generation, monitoring, and control components for exemplary sources of a wireless energy transfer system. Fig. 3 is a block diagram of a source comprising a half-bridge switching power amplifier and some of the associated measurement, tuning, and control circuitry. Fig. 4 is a block diagram of a source comprising a full-bridge switching amplifier and some of the associated measurement, tuning, and control circuitry.

[00125] The half bridge system topology depicted in Fig. 3 may comprise a processing unit that executes a control algorithm **328**. The processing unit executing a control algorithm **328** may be a microcontroller, an application specific circuit, a field programmable gate array, a processor, a digital signal processor, and the like. The processing unit may be a single device or it may be a network of devices. The control algorithm may run on any portion of the processing unit. The algorithm may be customized for certain applications and may comprise a combination of analog and digital circuits and signals. The master algorithm may measure and adjust voltage signals and levels, current signals and levels, signal phases, digital count settings, and the like.

[00126] The system may comprise an optional source/device and/or source/other resonator communication controller **332** coupled to wireless communication circuitry **312**. The optional source/device and/or source/other resonator communication controller **332** may be part of the same processing unit that executes the master control algorithm, it may be a part of a circuit within a microcontroller **302**, it may be external to the wireless power transmission modules, it may be substantially similar to communication controllers used in wire powered or battery powered applications but adapted to include some new or different functionality to enhance or support wireless power transmission.

[00127] The system may comprise a PWM generator **306** coupled to at least two transistor gate drivers **334** and may be controlled by the control algorithm. The two transistor gate drivers **334** may be coupled directly or via gate drive transformers to two power transistors **336** that drive the source resonator coil **344** through impedance matching network components **342**. The power transistors **336** may be coupled and powered with an adjustable DC supply **304** and the adjustable DC supply **304** may be controlled by a variable bus voltage,  $V_{bus}$ . The  $V_{bus}$  controller may be controlled by the control algorithm **328** and may be part of, or integrated into, a microcontroller **302** or other integrated circuits. The  $V_{bus}$  controller **326** may control the voltage output of an adjustable DC supply **304** which may be used to control power output of the amplifier and power delivered to the resonator coil **344**.

In other embodiments, the PWM generator **306** may control the phase angle between the current waveform through the load and the switching times of the power transistors **336** which may be used to control power output from the amplifier and power delivered to the resonator coil **344**. In other embodiments, the PWM generator **306** may control the duty cycle of the switch closure time to control power output from that amplifier and power delivered to the resonator coil **344**.

**[00128]** The system may comprise sensing and measurement circuitry including signal filtering and buffering circuits **318, 320** that may shape, modify, filter, process, buffer, and the like, signals prior to their input to processors and/or converters such as analog to digital converters (ADC) **314, 316**, for example. The processors and converters such as ADCs **314, 316** may be integrated into a microcontroller **302** or may be separate circuits that may be coupled to a processing core **330**. Based on measured signals, the control algorithm **328** may generate, limit, initiate, extinguish, control, adjust, or modify the operation of any of the PWM generator **306**, the communication controller **332**, the Vbus control **326**, the source impedance matching controller **338**, the filter/buffering elements, **318, 320**, the converters, **314, 316**, the resonator coil **344**, and may be part of, or integrated into, a microcontroller **302** or a separate circuit. The impedance matching networks **342** and resonator coils **344** may include electrically controllable, variable, or tunable components such as capacitors, switches, inductors, and the like, as described herein, and these components may have their component values or operating points adjusted according to signals received from the source impedance matching controller **338**. Components may be tuned to adjust the operation and characteristics of the resonator including the power delivered to and by the resonator, the resonant frequency of the resonator, the impedance of the resonator, the Q of the resonator, and any other coupled systems, and the like. The resonator may be any type or structure resonator described herein including a capacitively loaded loop resonator, a planer resonator comprising a magnetic material or any combination thereof.

**[00129]** The full bridge system topology depicted in Fig. 4 may comprise a processing unit that executes a master control algorithm **328**. The processing unit executing the control algorithm **328** may be a microcontroller, an application specific circuit, a field programmable gate array, a processor, a digital signal processor, and the like. The system may comprise a source/device and/or source/other resonator communication controller **332** coupled to wireless communication circuitry **312**. The source/device and/or source/other resonator communication controller **332** may be part of the same processing unit that executes that

master control algorithm, it may be a part or a circuit within a microcontroller **302**, it may be external to the wireless power transmission modules, it may be substantially similar to communication controllers used in wire powered or battery powered applications but adapted to include some new or different functionality to enhance or support wireless power transmission.

**[00130]** The system may comprise a PWM generator **410** with at least two outputs coupled to at least four transistor gate drivers **334** that may be controlled by signals generated in a master control algorithm. The four transistor gate drivers **334** may be coupled to four power transistors **336** directly or via gate drive transformers that may drive the source resonator coil **344** through impedance matching networks **342**. The power transistors **336** may be coupled and powered with an adjustable DC supply **304** and the adjustable DC supply **304** may be controlled by a Vbus controller **326** which may be controlled by a master control algorithm. The Vbus controller **326** may control the voltage output of the adjustable DC supply **304** which may be used to control power output of the amplifier and power delivered to the resonator coil **344**. In other embodiments, the PWM generator **410** may control the relative phase angle for the two halves of the bridge between the current waveform through the load and the switching times of the power transistors **336** which may be used to control power output from the amplifier and power delivered to the resonator coil **344**. In other embodiments, the PWM generator **410** may control the duty cycle of the switch closure time to control power output from that amplifier and power delivered to the resonator coil **344**.

**[00131]** The system may comprise sensing and measurement circuitry including signal filtering and buffering circuits **318, 320** and differential/single ended conversion circuitry **402, 404** that may shape, modify, filter, process, buffer, and the like, signals prior to being input to processors and/or converters such as analog to digital converters (ADC) **314, 316**. The processors and/or converters such as ADC **314, 316** may be integrated into a microcontroller **302** or may be separate circuits that may be coupled to a processing core **330**. Based on measured signals, the master control algorithm may generate, limit, initiate, extinguish, control, adjust, or modify the operation of any of the PWM generator **410**, the communication controller **332**, the Vbus controller **326**, the source impedance matching controller **338**, the filter/buffering elements, **318, 320**, differential/single ended conversion circuitry **402, 404**, the converters, **314, 316**, the resonator coil **344**, and may be part of or integrated into a microcontroller **302** or a separate circuit.

[00132] Impedance matching networks **342** and resonator coils **344** may comprise electrically controllable, variable, or tunable components such as capacitors, switches, inductors, and the like, as described herein, and these components may have their component values or operating points adjusted according to signals received from the source impedance matching controller **338**. Components may be tuned to enable tuning of the operation and characteristics of the resonator including the power delivered to and by the resonator, the resonant frequency of the resonator, the impedance of the resonator, the Q of the resonator, and any other coupled systems, and the like. The resonator may be any type or structure resonator described herein including a capacitively loaded loop resonator, a planar resonator comprising a magnetic material or any combination thereof.

[00133] Impedance matching networks may comprise fixed value components such as capacitors, inductors, and networks of components as described herein. Parts of the impedance matching networks, A, B and C, may comprise inductors, capacitors, transformers, and series and parallel combinations of such components, as described herein. In some embodiments, parts of the impedance matching networks A, B, and C, may be empty (short-circuited). In some embodiments, part B comprises a series combination of an inductor and a capacitor, and part C is empty.

[00134] The full bridge topology may allow operation at higher output power levels using the same DC bus voltage as an equivalent half bridge amplifier. The half bridge exemplary topology of Fig. 3 may provide a single-ended drive signal, while the exemplary full bridge topology of Fig. 4 may provide a differential drive to the source resonator **308**. The impedance matching topologies and components and the resonator structure may be different for the two systems, as discussed herein.

[00135] The exemplary systems depicted in Figures 3 and 4 may further include fault detection circuitry **340** that may be used to trigger the shutdown of the microcontroller in the source amplifier or to change or interrupt the operation of the amplifier. This protection circuitry may comprise a high speed comparator or comparators to monitor the amplifier return current, the amplifier bus voltage ( $V_{bus}$ ) from the DC supply **304**, the voltage across the source resonator **308** and/or the optional tuning board, or any other voltage or current signals that may cause damage to components in the system or may yield undesirable operating conditions. Preferred embodiments may depend on the potentially undesirable operating modes associated with different applications. In some embodiments, protection circuitry may not be implemented or circuits may not be populated. In some embodiments,

system and component protection may be implemented as part of a master control algorithm and other system monitoring and control circuits. In embodiments, dedicated fault circuitry **340** may include an output (not shown) coupled to a master control algorithm **328** that may trigger a system shutdown, a reduction of the output power (e.g. reduction of Vbus), a change to the PWM generator, a change in the operating frequency, a change to a tuning element, or any other reasonable action that may be implemented by the control algorithm **328** to adjust the operating point mode, improve system performance, and/or provide protection.

**[00136]** The exemplary systems depicted in Figures 3 and 4 may be configured so that the DC (or slowly varying AC) power supplied to the switches can be from a power source with varying power and/or output impedance. For example, the DC supply **304** may comprise a battery with an output voltage and output resistance that both vary as a function of the battery charge state. Or, the DC supply **304** may comprise a photovoltaic panel with a voltage and/or current that may vary as a function of environmental conditions such as solar illumination and temperature. In embodiments, the Vbus controller **326** may allow for tuning of the output impedance of the variable power source so that efficient wireless energy transfer is possible. In other embodiments, the PWM generator may allow for adjustment of the phase angle for switching the transistors **336** so that the optimum power can be extracted from the variable power source. For example, the switching times may be selected so that the input impedance of the amplifier matches the output impedance of the variable power source. In other examples, such as for the photovoltaic panel, the switching times may be selected so that an impedance is applied to the output of the photovoltaic panel that maximizes energy extraction from the photovoltaic panel. Those skilled in the art will understand that this general principle applies to other variable power sources including wind-powered generators, heat-powered generators, water-powered generators, fuel cells, batteries, and the like.

**[00137]** As described herein, sources in wireless power transfer systems may use a measurement of the input impedance of the impedance matching network **342** driving source resonator coil **344** as an error or control signal for a system control loop that may be part of the master control algorithm. In exemplary embodiments, variations in any combination of three parameters may be used to tune the wireless power source to compensate for changes in environmental conditions, for changes in coupling, for changes in device power demand, for changes in module, circuit, component or subsystem performance, for an increase or decrease in the number or sources, devices, or repeaters in the system, for user initiated changes, and the like. In exemplary embodiments, changes to the amplifier duty cycle, to the component



values of the variable electrical components such as variable capacitors and inductors, and to the DC bus voltage may be used to change the operating point or operating range of the wireless source and improve some system operating value. The specifics of the control algorithms employed for different applications may vary depending on the desired system performance and behavior.

**[00138]** Impedance measurement circuitry such as described herein, and shown in Figures 3 and 4, may be implemented using two-channel simultaneous sampling ADCs and these ADCs may be integrated into a microcontroller chip or may be part of a separate circuit. Simultaneously sampling of the voltage and current signals at the input to a source resonator's impedance matching network and/or at the source resonator, may yield the phase and magnitude information of the current and voltage signals and may be processed using known signal processing techniques to yield complex impedance parameters. In some embodiments, monitoring only the voltage signals or only the current signals may be sufficient.

**[00139]** The impedance measurements described herein may use direct sampling methods which may be relatively simpler than some other known sampling methods. In embodiments, measured voltage and current signals may be conditioned, filtered and scaled by filtering/buffering circuitry before being input to ADCs. In embodiments, the filter/buffering circuitry may be adjustable to work at a variety of signal levels and frequencies, and circuit parameters such as filter shapes and widths may be adjusted manually, electronically, automatically, in response to a control signal, by the master control algorithm, and the like. Exemplary embodiments of filter/buffering circuits are shown in Figures 3, 4, and 5.

**[00140]** Fig. 5 shows more detailed views of exemplary circuit components that may be used in filter/buffering circuitry. In embodiments, and depending on the types of ADCs used in the system designs, single-ended amplifier topologies may reduce the complexity of the analog signal measurement paths used to characterize system, subsystem, module and/or component performance by eliminating the need for hardware to convert from differential to single-ended signal formats. In other implementations, differential signal formats may be preferable. The implementations shown in Fig. 5 are exemplary, and should not be construed to be the only possible way to implement the functionality described herein. Rather it should be understood that the analog signal path may employ components with different input requirements and hence may have different signal path architectures.

[00141] In both the single ended and differential amplifier topologies, the input current to the impedance matching networks 342 driving the resonator coils 344 may be obtained by measuring the voltage across a capacitor 324, or via a current sensor of some type. For the exemplary single-ended amplifier topology in Fig. 3, the current may be sensed on the ground return path from the impedance matching network 342. For the exemplary differential power amplifier depicted in Fig. 4, the input current to the impedance matching networks 342 driving the resonator coils 344 may be measured using a differential amplifier across the terminals of a capacitor 324 or via a current sensor of some type. In the differential topology of Fig. 4, the capacitor 324 may be duplicated at the negative output terminal of the source power amplifier.

[00142] In both topologies, after single ended signals representing the input voltage and current to the source resonator and impedance matching network are obtained, the signals may be filtered 502 to obtain the desired portions of the signal waveforms. In embodiments, the signals may be filtered to obtain the fundamental component of the signals. In embodiments, the type of filtering performed, such as low pass, bandpass, notch, and the like, as well as the filter topology used, such as elliptical, Chebyshev, Butterworth, and the like, may depend on the specific requirements of the system. In some embodiments, no filtering will be required.

[00143] The voltage and current signals may be amplified by an optional amplifier 504. The gain of the optional amplifier 504 may be fixed or variable. The gain of the amplifier may be controlled manually, electronically, automatically, in response to a control signal, and the like. The gain of the amplifier may be adjusted in a feedback loop, in response to a control algorithm, by the master control algorithm, and the like. In embodiments, required performance specifications for the amplifier may depend on signal strength and desired measurement accuracy, and may be different for different application scenarios and control algorithms.

[00144] The measured analog signals may have a DC offset added to them, 506, which may be required to bring the signals into the input voltage range of the ADC which for some systems may be 0 to 3.3V. In some systems this stage may not be required, depending on the specifications of the particular ADC used.

[00145] As described above, the efficiency of power transmission between a power generator and a power load may be impacted by how closely matched the output impedance of the generator is to the input impedance of the load. In an exemplary system as shown in

Fig. 6A, power may be delivered to the load at a maximum possible efficiency, when the input impedance of the load **604** is equal to the complex conjugate of the internal impedance of the power generator or the power amplifier **602**. Designing the generator or load impedance to obtain a high and/or maximum power transmission efficiency may be called "impedance matching". Impedance matching may be performed by inserting appropriate networks or sets of elements such as capacitors, resistors, inductors, transformers, switches and the like, to form an impedance matching network **606**, between a power generator **602** and a power load **604** as shown in Fig. 6B. In other embodiments, mechanical adjustments and changes in element positioning may be used to achieve impedance matching. As described above for varying loads, the impedance matching network **606** may include variable components that are dynamically adjusted to ensure that the impedance at the generator terminals looking towards the load and the characteristic impedance of the generator remain substantially complex conjugates of each other, even in dynamic environments and operating scenarios. In embodiments, dynamic impedance matching may be accomplished by tuning the duty cycle, and/or the phase, and/or the frequency of the driving signal of the power generator or by tuning a physical component within the power generator, such as a capacitor, as depicted in Fig. 6C. Such a tuning mechanism may be advantageous because it may allow impedance matching between a power generator **608** and a load without the use of a tunable impedance matching network, or with a simplified tunable impedance matching network **606**, such as one that has fewer tunable components for example. In embodiments, tuning the duty cycle, and/or frequency, and/or phase of the driving signal to a power generator may yield a dynamic impedance matching system with an extended tuning range or precision, with higher power, voltage and/or current capabilities, with faster electronic control, with fewer external components, and the like. The impedance matching methods, architectures, algorithms, protocols, circuits, measurements, controls, and the like, described below, may be useful in systems where power generators drive high-Q magnetic resonators and in high-Q wireless power transmission systems as described herein. In wireless power transfer systems a power generator may be a power amplifier driving a resonator, sometimes referred to as a source resonator, which may be a load to the power amplifier. In wireless power applications, it may be preferable to control the impedance matching between a power amplifier and a resonator load to control the efficiency of the power delivery from the power amplifier to the resonator. The impedance matching may be accomplished, or accomplished in part, by tuning or adjusting the duty cycle, and/or the

phase, and/or the frequency of the driving signal of the power amplifier that drives the resonator.

**[00146]**      Efficiency of switching amplifiers

**[00147]**      Switching amplifiers, such as class D, E, F amplifiers, and the like or any combinations thereof, deliver power to a load at a maximum efficiency when almost no power is dissipated in the switching elements of the amplifier. This operating condition may be accomplished by designing the system so that the switching operations which are most critical (namely those that are most likely to lead to switching losses) are done when both the voltage across the switching element and the current through the switching element are nearly zero. These conditions may be referred to as Zero Voltage Switching (ZVS) and Zero Current Switching (ZCS) conditions respectively. When an amplifier operates at ZVS and ZCS either the voltage across the switching element or the current through the switching element is zero and thus no power can be dissipated in the switch. Since a switching amplifier may convert DC (or very low frequency AC) power to AC power at a specific frequency or range of frequencies, a filter may be introduced before the load to prevent unwanted harmonics that may be generated by the switching process from reaching the load and being dissipated there. In embodiments, a switching amplifier may be designed to operate at maximum efficiency of power conversion, when connected to a resonant load, with a quality factor (say  $Q > 5$ ), and of a specific impedance  $Z_o^* = R_o + jX_o$ , which leads to simultaneous ZVS and ZCS. We define  $Z_o = R_o - jX_o$  as the characteristic impedance of the amplifier, so that achieving maximum power transmission efficiency is equivalent to impedance matching the resonant load to the characteristic impedance of the amplifier.

**[00148]**      In a switching amplifier, the switching frequency of the switching elements,  $f_{switch}$ , wherein  $f_{switch} = \omega/2\pi$  and the duty cycle,  $dc$ , of the ON switch-state duration of the switching elements may be the same for all switching elements of the amplifier. In this specification, we will use the term “class D” to denote both class D and class DE amplifiers, that is, switching amplifiers with  $dc \leq 50\%$ .

**[00149]**      The value of the characteristic impedance of the amplifier may depend on the operating frequency, the amplifier topology, and the switching sequence of the switching elements. In some embodiments, the switching amplifier may be a half-bridge topology and, in some embodiments, a full-bridge topology. In some embodiments, the switching amplifier may be class D and, in some embodiments, class E. In any of the above embodiments,

assuming the elements of the bridge are symmetric, the characteristic impedance of the switching amplifier has the form

$$R_o = F_R(dc)/\omega C_a, X_o = F_X(dc)/\omega C_a, \quad (1)$$

where  $dc$  is the duty cycle of ON switch-state of the switching elements, the functions  $F_R(dc)$  and  $F_X(dc)$  are plotted in Fig. 7 (both for class D and E),  $\omega$  is the frequency at which the switching elements are switched, and  $C_a = n_a C_{switch}$  where  $C_{switch}$  is the capacitance across each switch, including both the transistor output capacitance and also possible external capacitors placed in parallel with the switch, while  $n_a = 1$  for a full bridge and  $n_a = 2$  for a half bridge. For class D, one can also write the analytical expressions

$$F_R(dc) = \sin^2 u / \pi, \quad F_X(dc) = (u - \sin u * \cos u) / \pi, \quad (2)$$

where  $u = \pi(1 - 2 * dc)$ , indicating that the characteristic impedance level of a class D amplifier decreases as the duty cycle,  $dc$ , increases towards 50%. For a class D amplifier operation with  $dc=50\%$ , achieving ZVS and ZCS is possible only when the switching elements have practically no output capacitance ( $C_a = 0$ ) and the load is exactly on resonance ( $X_o = 0$ ), while  $R_o$  can be arbitrary.

#### [00150] Impedance Matching Networks

[00151] In applications, the driven load may have impedance that is very different from the characteristic impedance of the external driving circuit, to which it is connected. Furthermore, the driven load may not be a resonant network. An Impedance Matching Network (IMN) is a circuit network that may be connected before a load as in Fig. 6B, in order to regulate the impedance that is seen at the input of the network consisting of the IMN circuit and the load. An IMN circuit may typically achieve this regulation by creating a resonance close to the driving frequency. Since such an IMN circuit accomplishes all conditions needed to maximize the power transmission efficiency from the generator to the load (resonance and impedance matching – ZVS and ZCS for a switching amplifier), in embodiments, an IMN circuit may be used between the driving circuit and the load.

[00152] For an arrangement shown in Fig. 6B, let the input impedance of the network consisting of the Impedance Matching Network (IMN) circuit and the load (denoted together from now on as IMN+load) be  $Z_l = R_l(\omega) + jX_l(\omega)$ . The impedance matching conditions of this network to the external circuit with characteristic impedance  $Z_o = R_o - jX_o$  are then  $R_l(\omega) = R_o, X_l(\omega) = X_o$ .

#### [00153] Methods for tunable Impedance Matching of a variable load

**[00154]** In embodiments where the load may be variable, impedance matching between the load and the external driving circuit, such as a linear or switching power amplifier, may be achieved by using adjustable/tunable components in the IMN circuit that may be adjusted to match the varying load to the fixed characteristic impedance  $Z_o$  of the external circuit (Fig. 6B). To match both the real and imaginary parts of the impedance two tunable/variable elements in the IMN circuit may be needed.

**[00155]** In embodiments, the load may be inductive (such as a resonator coil) with impedance  $R + j\omega L$ , so the two tunable elements in the IMN circuit may be two tunable capacitance networks or one tunable capacitance network and one tunable inductance network or one tunable capacitance network and one tunable mutual inductance network.

**[00156]** In embodiments where the load may be variable, the impedance matching between the load and the driving circuit, such as a linear or switching power amplifier, may be achieved by using adjustable/tunable components or parameters in the amplifier circuit that may be adjusted to match the characteristic impedance  $Z_o$  of the amplifier to the varying (due to load variations) input impedance of the network consisting of the IMN circuit and the load (IMN+load), where the IMN circuit may also be tunable (Fig. 6C). To match both the real and imaginary parts of the impedance, a total of two tunable/variable elements or parameters in the amplifier and the IMN circuit may be needed. The disclosed impedance matching method can reduce the required number of tunable/variable elements in the IMN circuit or even completely eliminate the requirement for tunable/variable elements in the IMN circuit. In some examples, one tunable element in the power amplifier and one tunable element in the IMN circuit may be used. In some examples, two tunable elements in the power amplifier and no tunable element in the IMN circuit may be used.

**[00157]** In embodiments, the tunable elements or parameters in the power amplifier may be the frequency, amplitude, phase, waveform, duty cycle and the like of the drive signals applied to transistors, switches, diodes and the like.

**[00158]** In embodiments, the power amplifier with tunable characteristic impedance may be a tunable switching amplifier of class D, E, F or any combinations thereof.

Combining Equations (1) and (2), the impedance matching conditions for this network are

$$R_l(\omega) = F_R(dc)/\omega C_a, X_l(\omega) = F_X(dc)/\omega C_a \quad (3).$$

**[00159]** In some examples of a tunable switching amplifier, one tunable element may be the capacitance  $C_a$ , which may be tuned by tuning the external capacitors placed in parallel with the switching elements.

**[00160]** In some examples of a tunable switching amplifier, one tunable element may be the duty cycle  $dc$  of the ON switch-state of the switching elements of the amplifier. Adjusting the duty cycle,  $dc$ , via Pulse Width Modulation (PWM) has been used in switching amplifiers to achieve output power control. In this specification, we disclose that PWM may also be used to achieve impedance matching, namely to satisfy Eq.(3), and thus maximize the amplifier efficiency.

**[00161]** In some examples of a tunable switching amplifier one tunable element may be the switching frequency, which is also the driving frequency of the IMN+load network and may be designed to be substantially close to the resonant frequency of the IMN+load network. Tuning the switching frequency may change the characteristic impedance of the amplifier and the impedance of the IMN+load network. The switching frequency of the amplifier may be tuned appropriately together with one more tunable parameters, so that Eqs.(3) are satisfied.

**[00162]** A benefit of tuning the duty cycle and/or the driving frequency of the amplifier for dynamic impedance matching is that these parameters can be tuned electronically, quickly, and over a broad range. In contrast, for example, a tunable capacitor that can sustain a large voltage and has a large enough tunable range and quality factor may be expensive, slow or unavailable for with the necessary component specifications

**[00163]** Examples of methods for tunable Impedance Matching of a variable load

**[00164]** A simplified circuit diagram showing the circuit level structure of a class D power amplifier **802**, impedance matching network **804** and an inductive load **806** is shown in Fig. 8. The diagram shows the basic components of the system with the switching amplifier **804** comprising a power source **810**, switching elements **808**, and capacitors. The impedance matching network **804** comprising inductors and capacitors, and the load **806** modeled as an inductor and a resistor.

**[00165]** An exemplary embodiment of this inventive tuning scheme comprises a half-bridge class-D amplifier operating at switching frequency  $f$  and driving a low-loss inductive element  $R + j\omega L$  via an IMN, as shown in Fig. 8.

**[00166]** In some embodiments  $L'$  may be tunable.  $L'$  may be tuned by a variable tapping point on the inductor or by connecting a tunable capacitor in series or in parallel to the inductor. In some embodiments  $C_a$  may be tunable. For the half bridge topology,  $C_a$  may be tuned by varying either one or both capacitors  $C_{switch}$ , as only the parallel sum of these capacitors matters for the amplifier operation. For the full bridge topology,  $C_a$  may be tuned

by varying either one, two, three or all capacitors  $C_{switch}$ , as only their combination (series sum of the two parallel sums associated with the two halves of the bridge) matters for the amplifier operation.

**[00167]** In some embodiments of tunable impedance matching, two of the components of the IMN may be tunable. In some embodiments,  $L'$  and  $C_2$  may be tuned. Then, Fig. 9 shows the values of the two tunable components needed to achieve impedance matching as functions of the varying  $R$  and  $L$  of the inductive element, and the associated variation of the output power (at given DC bus voltage) of the amplifier, for  $f = 250kHz$ ,  $dc = 40\%$ ,  $C_a = 640pF$  and  $C_1 = 10nF$ . Since the IMN always adjusts to the fixed characteristic impedance of the amplifier, the output power is always constant as the inductive element is varying.

**[00168]** In some embodiments of tunable impedance matching, elements in the switching amplifier may also be tunable. In some embodiments the capacitance  $C_a$  along with the IMN capacitor  $C_2$  may be tuned. Then, Fig. 10 shows the values of the two tunable components needed to achieve impedance matching as functions of the varying  $R$  and  $L$  of the inductive element, and the associated variation of the output power (at given DC bus voltage) of the amplifier for  $f = 250kHz$ ,  $dc = 40\%$ ,  $C_1 = 10nF$  and  $\omega L' = 1000\Omega$ . It can be inferred from Fig. 10 that  $C_2$  needs to be tuned mainly in response to variations in  $L$  and that the output power decreases as  $R$  increases.

**[00169]** In some embodiments of tunable impedance matching, the duty cycle  $dc$  along with the IMN capacitor  $C_2$  may be tuned. Then, Fig. 11D shows the values of the two tunable parameters needed to achieve impedance matching as functions of the varying  $R$  and  $L$  of the inductive element, and the associated variation of the output power (at given DC bus voltage) of the amplifier for  $f = 250kHz$ ,  $C_a = 640pF$ ,  $C_1 = 10nF$  and  $\omega L' = 1000\Omega$ . It can be inferred from Fig. 11D that  $C_2$  needs to be tuned mainly in response to variations in  $L$  and that the output power decreases as  $R$  increases.

**[00170]** In some embodiments of tunable impedance matching, the capacitance  $C_a$  along with the IMN inductor  $L'$  may be tuned. Then, Fig. 11A shows the values of the two tunable components needed to achieve impedance matching as functions of the varying  $R$  of the inductive element, and the associated variation of the output power (at given DC bus voltage) of the amplifier for  $f = 250kHz$ ,  $dc = 40\%$ ,  $C_1 = 10nF$  and  $C_2 = 7.5nF$ . It can be inferred from Fig. 11A that the output power decreases as  $R$  increases.



[00171] In some embodiments of tunable impedance matching, the duty cycle  $dc$  along with the IMN inductor  $L'$  may be tuned. Then, Fig. 11B shows the values of the two tunable parameters needed to achieve impedance matching as functions of the varying  $R$  of the inductive element, and the associated variation of the output power (at given DC bus voltage) of the amplifier for  $f = 250kHz$ ,  $C_a = 640pF$ ,  $C_1 = 10nF$  and  $C_2 = 7.5nF$  as functions of the varying  $R$  of the inductive element. It can be inferred from Fig. 11B that the output power decreases as  $R$  increases.

[00172] In some embodiments of tunable impedance matching, only elements in the switching amplifier may be tunable with no tunable elements in the IMN. In some embodiments the duty cycle  $dc$  along with the capacitance  $C_a$  may be tuned. Then, Fig. 11C, shows the values of the two tunable parameters needed to achieve impedance matching as functions of the varying  $R$  of the inductive element, and the associated variation of the output power (at given DC bus voltage) of the amplifier for  $f = 250kHz$ ,  $C_1 = 10nF$ ,  $C_2 = 7.5nF$  and  $\omega L' = 1000\Omega$ . It can be inferred from Fig. 11C that the output power is a non-monotonic function of  $R$ . These embodiments may be able to achieve dynamic impedance matching when variations in  $L$  (and thus the resonant frequency) are modest.

[00173] In some embodiments, dynamic impedance matching with fixed elements inside the IMN, also when  $L$  is varying greatly as explained earlier, may be achieved by varying the driving frequency of the external frequency  $f$  (e.g. the switching frequency of a switching amplifier) so that it follows the varying resonant frequency of the resonator. Using the switching frequency  $f$  and the switch duty cycle  $dc$  as the two variable parameters, full impedance matching can be achieved as  $R$  and  $L$  are varying without the need of any variable components. Then, Fig. 12 shows the values of the two tunable parameters needed to achieve impedance matching as functions of the varying  $R$  and  $L$  of the inductive element, and the associated variation of the output power (at given DC bus voltage) of the amplifier for  $C_a = 640pF$ ,  $C_1 = 10nF$ ,  $C_2 = 7.5nF$  and  $L' = 637\mu H$ . It can be inferred from Fig. 12 that the frequency  $f$  needs to be tuned mainly in response to variations in  $L$ , as explained earlier.

[00174] Tunable Impedance Matching for systems of wireless power transmission

[00175] In applications of wireless power transfer the low-loss inductive element may be the coil of a source resonator coupled to one or more device resonators or other resonators, such as repeater resonators, for example. The impedance of the inductive element  $R + j\omega L$  may include the reflected impedances of the other resonators on the coil of the source resonator. Variations of  $R$  and  $L$  of the inductive element may occur due to external

perturbations in the vicinity of the source resonator and/or the other resonators or thermal drift of components. Variations of  $R$  and  $L$  of the inductive element may also occur during normal use of the wireless power transmission system due to relative motion of the devices and other resonators with respect to the source. The relative motion of these devices and other resonators with respect to the source, or relative motion or position of other sources, may lead to varying coupling (and thus varying reflected impedances) of the devices to the source. Furthermore, variations of  $R$  and  $L$  of the inductive element may also occur during normal use of the wireless power transmission system due to changes within the other coupled resonators, such as changes in the power draw of their loads. All the methods and embodiments disclosed so far apply also to this case in order to achieve dynamic impedance matching of this inductive element to the external circuit driving it.

**[00176]** To demonstrate the presently disclosed dynamic impedance matching methods for a wireless power transmission system, consider a source resonator including a low-loss source coil, which is inductively coupled to the device coil of a device resonator driving a resistive load.

**[00177]** In some embodiments, dynamic impedance matching may be achieved at the source circuit. In some embodiments, dynamic impedance matching may also be achieved at the device circuit. When full impedance matching is obtained (both at the source and the device), the effective resistance of the source inductive element (namely the resistance of the source coil  $R_s$  plus the reflected impedance from the device) is  $R = R_s\sqrt{1 + U_{sd}^2}$ . (Similarly the effective resistance of the device inductive element is  $R_d\sqrt{1 + U_{sd}^2}$ , where  $R_d$  is the resistance of the device coil.) Dynamic variation of the mutual inductance between the coils due to motion results in a dynamic variation of  $U_{sd} = \omega M_{sd}/\sqrt{R_s R_d}$ . Therefore, when both source and device are dynamically tuned, the variation of mutual inductance is seen from the source circuit side as a variation in the source inductive element resistance  $R$ . Note that in this type of variation, the resonant frequencies of the resonators may not change substantially, since  $L$  may not be changing. Therefore, all the methods and examples presented for dynamic impedance matching may be used for the source circuit of the wireless power transmission system.

**[00178]** Note that, since the resistance  $R$  represents both the source coil and the reflected impedances of the device coils to the source coil, in Figures 9-12, as  $R$  increases due to the increasing  $U$ , the associated wireless power transmission efficiency increases. In some embodiments, an approximately constant power may be required at the load driven by the

device circuitry. To achieve a constant level of power transmitted to the device, the required output power of the source circuit may need to decrease as  $U$  increases. If dynamic impedance matching is achieved via tuning some of the amplifier parameters, the output power of the amplifier may vary accordingly. In some embodiments, the automatic variation of the output power is preferred to be monotonically decreasing with  $R$ , so that it matches the constant device power requirement. In embodiments where the output power level is accomplished by adjusting the DC driving voltage of the power generator, using an impedance matching set of tunable parameters which leads to monotonically decreasing output power vs.  $R$  will imply that constant power can be kept at the power load in the device with only a moderate adjustment of the DC driving voltage. In embodiments, where the “knob” to adjust the output power level is the duty cycle  $dc$  or the phase of a switching amplifier or a component inside an Impedance Matching Network, using an impedance matching set of tunable parameters which leads to monotonically decreasing output power vs.  $R$  will imply that constant power can be kept at the power load in the device with only a moderate adjustment of this power “knob”.

**[00179]** In the examples of Figures 9-12, if  $R_s = 0.19\Omega$ , then the range  $R = 0.2 - 2\Omega$  corresponds approximately to  $U_{sd} = 0.3 - 10.5$ . For these values, in Fig. 14, we show with dashed lines the output power (normalized to DC voltage squared) required to keep a constant power level at the load, when both source and device are dynamically impedance matched. The similar trend between the solid and dashed lines explains why a set of tunable parameters with such a variation of output power may be preferable.

**[00180]** In some embodiments, dynamic impedance matching may be achieved at the source circuit, but impedance matching may not be achieved or may only partially be achieved at the device circuit. As the mutual inductance between the source and device coils varies, the varying reflected impedance of the device to the source may result in a variation of both the effective resistance  $R$  and the effective inductance  $L$  of the source inductive element. The methods presented so far for dynamic impedance matching are applicable and can be used for the tunable source circuit of the wireless power transmission system.

**[00181]** As an example, consider the circuit of Fig. 14, where  $f = 250kHz$ ,  $C_a = 640pF$ ,  $R_s = 0.19\Omega$ ,  $L_s = 100\mu H$ ,  $C_{1s} = 10nF$ ,  $\omega L'_s = 1000\Omega$ ,  $R_d = 0.3\Omega$ ,  $L_d = 40\mu H$ ,  $C_{1d} = 87.5nF$ ,  $C_{2d} = 13nF$ ,  $\omega L'_d = 400\Omega$  and  $Z_l = 50\Omega$ , where  $s$  and  $d$  denote the source and device resonators respectively and the system is matched at  $U_{sd} = 3$ . Tuning the duty cycle  $dc$  of the switching amplifier and the capacitor  $C_{2s}$  may be used to dynamically

impedance match the source, as the non-tunable device is moving relatively to the source changing the mutual inductance  $M$  between the source and the device. In Fig. 14, we show the required values of the tunable parameters along with the output power per DC voltage of the amplifier. The dashed line again indicates the output power of the amplifier that would be needed so that the power at the load is a constant value.

**[00182]** In some embodiments, tuning the driving frequency  $f$  of the source driving circuit may still be used to achieve dynamic impedance matching at the source for a system of wireless power transmission between the source and one or more devices. As explained earlier, this method enables full dynamic impedance matching of the source, even when there are variations in the source inductance  $L_s$  and thus the source resonant frequency. For efficient power transmission from the source to the devices, the device resonant frequencies must be tuned to follow the variations of the matched driving and source-resonant frequencies. Tuning a device capacitance (for example, in the embodiment of Fig. 13  $C_{1d}$  or  $C_{2d}$ ) may be necessary, when there are variations in the resonant frequency of either the source or the device resonators. In fact, in a wireless power transfer system with multiple sources and devices, tuning the driving frequency alleviates the need to tune only one source-object resonant frequency, however, all the rest of the objects may need a mechanism (such as a tunable capacitance) to tune their resonant frequencies to match the driving frequency.

**[00183] Resonator Thermal Management**

**[00184]** In wireless energy transfer systems, some portion of the energy lost during the wireless transfer process is dissipated as heat. Energy may be dissipated in the resonator components themselves. For example, even high-Q conductors and components have some loss or resistance, and these conductors and components may heat up when electric currents and/or electromagnetic fields flow through them. Energy may be dissipated in materials and objects around a resonator. For example, eddy currents dissipated in imperfect conductors or dielectrics surrounding or near-by the resonator may heat up those objects. In addition to affecting the material properties of those objects, this heat may be transferred through conductive, radiative, or convective processes to the resonator components. Any of these heating effects may affect the resonator Q, impedance, frequency, etc., and therefore the performance of the wireless energy transfer system.

**[00185]** In a resonator comprising a block or core of magnetic material, heat may be generated in the magnetic material due to hysteresis losses and to resistive losses resulting from induced eddy currents. Both effects depend on the magnetic flux density in the

material, and both can create significant amounts of heat, especially in regions where the flux density or eddy currents may be concentrated or localized. In addition to the flux density, the frequency of the oscillating magnetic field, the magnetic material composition and losses, and the ambient or operating temperature of the magnetic material may all impact how hysteresis and resistive losses heat the material.

**[00186]** In embodiments, the properties of the magnetic material such as the type of material, the dimensions of the block, and the like, and the magnetic field parameters may be chosen for specific operating power levels and environments to minimize heating of the magnetic material. In some embodiments, changes, cracks, or imperfections in a block of magnetic material may increase the losses and heating of the magnetic material in wireless power transmission applications.

**[00187]** For magnetic blocks with imperfections, or that are comprised of smaller size tiles or pieces of magnetic material arranged into a larger unit, the losses in the block may be uneven and may be concentrated in regions where there are inhomogeneities or relatively narrow gaps between adjacent tiles or pieces of magnetic material. For example, if an irregular gap exists in a magnetic block of material, then the effective reluctance of various magnetic flux paths through the material may be substantially irregular and the magnetic field may be more concentrated in portions of the block where the magnetic reluctance is lowest. In some cases, the effective reluctance may be lowest where the gap between tiles or pieces is narrowest or where the density of imperfections is lowest. Because the magnetic material guides the magnetic field, the magnetic flux density may not be substantially uniform across the block, but may be concentrated in regions offering relatively lower reluctance. Irregular concentrations of the magnetic field within a block of magnetic material may not be desirable because they may result in uneven losses and heat dissipation in the material.

**[00188]** For example, consider a magnetic resonator comprising a conductor **1506** wrapped around a block of magnetic material composed of two individual tiles **1502, 1504** of magnetic material joined such that they form a seam **1508** that is perpendicular to the axis of the conductor **1506** loops as depicted in Fig. 15. An irregular gap in the seam **1508** between the tiles of magnetic material **1502, 1504** may force the magnetic field **1512** (represented schematically by the dashed magnetic field lines) in the resonator to concentrate in a sub region **1510** of the cross section of the magnetic material. Since the magnetic field will follow the path of least reluctance, a path including an air gap between two pieces of magnetic material may create an effectively higher reluctance path than one that traverses the

width of the magnetic material at a point where the pieces of magnetic materials touch or have a smaller air gap. The magnetic flux density may therefore preferentially flow through a relatively small cross area of the magnetic material resulting in a high concentration of magnetic flux in that small area **1510**.

**[00189]** In many magnetic materials of interest, more inhomogeneous flux density distributions lead to higher overall losses. Moreover, the more inhomogeneous flux distribution may result in material saturation and cause localized heating of the area in which the magnetic flux is concentrated. The localized heating may alter the properties of the magnetic material, in some cases exacerbating the losses. For example, in the relevant regimes of operation of some materials, hysteresis and resistive losses increase with temperature. If heating the material increases material losses, resulting in more heating, the temperature of the material may continue to increase and even runaway if no corrective action is taken. In some instances, the temperature may reach 100C or more and may degrade the properties of the magnetic material and the performance of wireless power transfer. In some instances, the magnetic materials may be damaged, or the surrounding electronic components, packaging and/or enclosures may be damaged by the excessive heat.

**[00190]** In embodiments, variations or irregularities between tiles or pieces of the block of magnetic material may be minimized by machining, polishing, grinding, and the like, the edges of the tiles or pieces to ensure a tight fit between tiles of magnetic materials providing a substantially more uniform reluctance through the whole cross section of the block of magnetic material. In embodiments, a block of magnetic material may require a means for providing a compression force between the tiles to ensure the tiles are pressed tight together without gaps. In embodiments, an adhesive may be used between the tiles to ensure they remain in tight contact.

**[00191]** In embodiments the irregular spacing of adjacent tiles of magnetic material may be reduced by adding a deliberate gap between adjacent tiles of magnetic material. In embodiments a deliberate gap may be used as a spacer to ensure even or regular separations between magnetic material tiles or pieces. Deliberate gaps of flexible materials may also reduce irregularities in the spacings due to tile movement or vibrations. In embodiments, the edges of adjacent tiles of magnetic material may be taped, dipped, coated, and the like with an electrical insulator, to prevent eddy currents from flowing through reduced cross-sectional areas of the block, thus lowering the eddy current losses in the material. In embodiments a

separator may be integrated into the resonator packaging. The spacer may provide a spacing of 1mm or less.

**[00192]** In embodiments, the mechanical properties of the spacer between tiles may be chosen so as to improve the tolerance of the overall structure to mechanical effects such as changes in the dimensions and/or shape of the tiles due to intrinsic effects (e.g., magnetostriction, thermal expansion, and the like) as well as external shocks and vibrations. For example, the spacer may have a desired amount of mechanical give to accommodate the expansion and/or contraction of individual tiles, and may help reduce the stress on the tiles when they are subjected to mechanical vibrations, thus helping to reduce the appearance of cracks and other defects in the magnetic material.

**[00193]** In embodiments, it may be preferable to arrange the individual tiles that comprise the block of magnetic material to minimize the number of seams or gaps between tiles that are perpendicular to the dipole moment of the resonator. In embodiments it may be preferable to arrange and orient the tiles of magnetic material to minimize the gaps between tiles that are perpendicular to the axis formed by the loops of a conductor comprising the resonator.

**[00194]** For example, consider the resonator structure depicted in Fig. 16. The resonator comprises a conductor **1604** wrapped around a block of magnetic material comprising six separate individual tiles **1602** arranged in a three by two array. The arrangement of tiles results in two tile seams **1606, 1608** when traversing the block of magnetic material in one direction, and only one tile seam **1610** when traversing the block of magnetic material in the orthogonal direction. In embodiments, it may be preferable to wrap the conductor wire **1604** around the block of magnetic material such that the dipole moment of the resonator is perpendicular to the fewest number of tile seams. The inventors have observed that there is relatively less heating induced around seams and gaps **1606, 1608** that are parallel to the dipole moment of the resonator. Seams and gaps that run perpendicular to the dipole moment of the resonator may also be referred to as critical seams or critical seam areas. It may still be desirable, however, to electrically insulate gaps that run parallel to the dipole moment of the resonator (such as **1606** and **1608**) so as to reduce eddy current losses. Uneven contact between tiles separated by such parallel gaps may cause eddy currents to flow through narrow contact points, leading to large losses at such points.

**[00195]** In embodiments, irregularities in spacing may be tolerated with adequate cooling of the critical seam areas to prevent the localized degradation of material properties

when the magnetic material heats up. Maintaining the temperature of the magnetic material below a critical temperature may prevent a runaway effect caused by a sufficiently high temperature. With proper cooling of the critical seam area, the wireless energy transfer performance may be satisfactory despite the additional loss and heating effects due to irregular spacing, cracks, or gaps between tiles.

**[00196]** Effective heat sinking of the resonator structure to prevent excessive localized heating of the magnetic material poses several challenges. Metallic materials that are typically used for heatsinks and thermal conduction can interact with the magnetic fields used for wireless energy transfer by the resonators and affect the performance of the system. Their location, size, orientation, and use should be designed so as to not excessively lower the perturbed Q of the resonators in the presence of these heatsinking materials. In addition, owing to the relatively poor thermal conductivity of magnetic materials such as ferrites, a relatively large contact area between the heatsink and the magnetic material may be required to provide adequate cooling which may require placement of substantial amount of lossy materials close to the magnetic resonator.

**[00197]** In embodiments, adequate cooling of the resonator may be achieved with minimal effect on the wireless energy transfer performance with strategic placement of thermally conductive materials. In embodiments, strips of thermally conductive material may be placed in between loops of conductor wire and in thermal contact with the block of magnetic material.

**[00198]** One exemplary embodiment of a resonator with strips of thermally conductive material is depicted in Fig. 17. Fig. 17A shows the resonator structure without the conducting strips and with the block of magnetic material comprising smaller tiles of magnetic material forming gaps or seams. Strips of thermally conductive **1708** material may be placed in between the loops of the conductor **1702** and in thermal contact with the block of magnetic material **1704** as depicted in Figs. 17B and 17C. To minimize the effects of the strips on the parameters of the resonator, in some embodiments it may be preferable to arrange the strips parallel to the loops of conductor or perpendicular to the dipole moment of the resonator. The strips of conductor may be placed to cover as much or as many of the seams or gaps between the tiles as possible especially the seams between tiles that are perpendicular to the dipole moment of the resonator.

**[00199]** In embodiments the thermally conductive material may comprise copper, aluminum, brass, thermal epoxy, paste, pads, and the like, and may be any material that has a



thermal conductivity that is at least that of the magnetic material in the resonator ( $\sim 5\text{W}/(\text{K}\cdot\text{m})$  for some commercial ferrite materials). In embodiments where the thermally conductive material is also electrically conducting, the material may require a layer or coating of an electrical insulator to prevent shorting and direct electrical contact with the magnetic material or the loops of conductor of the resonator.

**[00200]** In embodiments the strips of thermally conductive material may be used to conduct heat from the resonator structure to a structure or medium that can safely dissipate the thermal energy. In embodiments the thermally conductive strips may be connected to a heat sink such as a large plate located above the strips of conductor that can dissipate the thermal energy using passive or forced convection, radiation, or conduction to the environment. In embodiments the system may include any number of active cooling systems that may be external or internal to the resonator structure that can dissipate the thermal energy from the thermally conducting strips and may include liquid cooling systems, forced air systems, and the like. For example, the thermally conducting strips may be hollow or comprise channels for coolant that may be pumped or forced through to cool the magnetic material. In embodiments, a field deflector made of a good electrical conductor (such as copper, silver, aluminum, and the like) may double as part of the heatsinking apparatus. The addition of thermally and electrically conducting strips to the space between the magnetic material and the field deflector may have a marginal effect on the perturbed  $Q$ , as the electromagnetic fields in that space are typically suppressed by the presence of the field deflector. Such conducting strips may be thermally connected to both the magnetic material and the field deflector to make the temperature distribution among different strips more homogeneous.

**[00201]** In embodiments the thermally conducting strips are spaced to allow at least one loop of conductor to wrap around the magnetic material. In embodiments the strips of thermally conductive material may be positioned only at the gaps or seams of the magnetic material. In other embodiments, the strips may be positioned to contact the magnetic material at substantially throughout its complete length. In other embodiments, the strips may be distributed to match the flux density within the magnetic material. Areas of the magnetic material which under normal operation of the resonator may have higher magnetic flux densities may have a higher density of contact with the thermally conductive strips. In embodiments depicted in Fig 17A) for example, the highest magnetic flux density in the magnetic material may be observed toward the center of the block of magnetic material and

the lower density may be toward the ends of the block in the direction of the dipole moment of the resonator.

**[00202]** To show how the use of thermally conducting strips helps to reduce the overall temperature in the magnetic material as well as the temperature at potential hot spots, the inventors have performed a finite element simulation of a resonator structure similar to that depicted in Fig. 17C. The structure was simulated operating at a frequency of 235 kHz and comprising a block of EPCOS N95 magnetic material measuring 30 cm x 30 cm x 5 mm excited by 10 turns of litz wire (symmetrically placed at 25 mm, 40 mm, 55 mm, 90 mm and 105 mm from the plane of symmetry of the structure) carrying 40 A of peak current each, and thermally connected to a 50 cm x 50 cm x 4 mm field deflector by means of three 3 x ¾ x 1' hollow square tubes (1/8" wall thickness) of aluminum (alloy 6063) whose central axes are placed at -75mm, 0 mm, and +75 from the symmetry plane of the structure. The perturbed Q due to the field deflector and hollow tubes was found to be 1400 (compared to 1710 for the same structure without the hollow tubes). The power dissipated in the shield and tubes was calculated to be 35.6 W, while that dissipated in the magnetic material was 58.3 W.

Assuming the structure is cooled by air convection and radiation and an ambient temperature of 24 °C, the maximum temperature in the structure was 85 °C (at points in the magnetic material approximately halfway between the hollow tubes) while the temperature in parts of the magnetic material in contact with the hollow tubes was approximately 68 °C. By comparison, the same resonator without the thermally conducting hollow tubes dissipated 62.0 W in the magnetic material for the same excitation current of 40 W peak and the maximum temperature in the magnetic material was found to be 111 °C.

**[00203]** The advantage of the conducting strips is more apparent still if we introduce a defect in a portion of the magnetic material that is in good thermal contact with the tubes. An air gap 10 cm long and 0.5 mm placed at the center of the magnetic material and oriented perpendicular to the dipole moment increases the power dissipated in the magnetic material to 69.9 W (the additional 11.6W relative to the previously discussed no-defect example being highly concentrated in the vicinity of the gap), but the conducting tube ensures that the maximum temperature in the magnetic material has only a relative modest increase of 11 °C to 96 °C. In contrast, the same defect without the conducting tubes leads to a maximum temperature of 161 °C near the defect. Cooling solutions other than convection and radiation, such as thermally connecting the conducting tubes body with large thermal mass or actively

cooling them, may lead to even lower operational temperatures for this resonator at the same current level.

**[00204]** In embodiments thermally conductive strips of material may be positioned at areas that may have the highest probability of developing cracks that may cause irregular gaps in the magnetic material. Such areas may be areas of high stress or strain on the material, or areas with poor support or backing from the packaging of the resonator. Strategically positioned thermally conductive strips may ensure that as cracks or irregular gaps develop in the magnetic material, the temperature of the magnetic material will be maintained below its critical temperature. The critical temperature may be defined as the Curie temperature of the magnetic material, or any temperature at which the characteristics of the resonator have been degraded beyond the desired performance parameters.

**[00205]** In embodiments the heatsinking structure may provide mechanical support to the magnetic material. In embodiments the heatsinking structure may be designed to have a desired amount of mechanical give (e.g., by using epoxy, thermal pads, and the like having suitable mechanical properties to thermally connect different elements of the structure) so as to provide the resonator with a greater amount of tolerance to changes in the intrinsic dimensions of its elements (due to thermal expansion, magnetostriction, and the like) as well as external shocks and vibrations, and prevent the formation of cracks and other defects.

**[00206]** In embodiments where the resonator comprises orthogonal windings wrapped around the magnetic material, the strips of conducting material may be tailored to make thermal contact with the magnetic material within areas delimited by two orthogonal sets of adjacent loops. In embodiments a strip may contain appropriate indentations to fit around the conductor of at least one orthogonal winding while making thermal contact with the magnetic material at least one point. In embodiments the magnetic material may be in thermal contact with a number of thermally conducting blocks placed between adjacent loops. The thermally conducting blocks may be in turn thermally connected to one another by means of a good thermal conductor and/or heatsinked.

**[00207]** Throughout this description although the term thermally conductive strips of material was used as an exemplary specimen of a shape of a material it should be understood by those skilled in the art that any shapes and contours may be substituted without departing from the spirit of the inventions. Squared, ovals, strips, dots, elongated shapes, and the like would all be within the spirit of the present invention.

**[00208]** **Communication in a Wireless Energy Transfer System**

**[00209]** A wireless energy transfer system may require a verification step to ensure that energy is being transferred from a designated source to a designated device. In a wireless energy transfer system, a source and a device do not require physical contact and may be separated by distances of centimeters or more. In some configurations with multiple sources or multiple devices that are within the wireless power transfer range of one another it may be necessary to determine or verify the source and device that are transferring power between each other.

**[00210]** Verification of an energy transfer may be important when an out-of-band communication channel is used in the wireless energy transfer system. An out-of-band communication channel may be used to transfer data between different components of the wireless energy transfer system. Communication between a source and a device or between multiple devices, sources, and the like may be used to coordinate the wireless energy transfer or to adjust the parameters of a wireless energy transfer system to optimize efficiency, power delivery, and the like.

**[00211]** In some embodiments all of the signaling and communication may be performed using an in-band communication channel that uses the same fields as are used for energy transfer. Using only the in-band communication channel may have the advantage of not requiring a separate verification step. In some embodiments however, a separate out-of-band communication channel may be more desirable. An out-of-band communication channel may be less expensive and support higher data rates. An out-of-band communication channel that does not use near-field communication may support longer distance allowing resonator discovery. Likewise a separate out-of-band communication channel may not require power to be applied to the resonators and communication and likewise communication may occur without disruption of the power transfer.

**[00212]** An out-of-band communication channel is a channel that does not use the magnetic fields used for energy transfer by the resonators. The communication channel may use a separate antenna and a separate signaling protocol that is disjoint from the energy transfer resonator and magnetic fields. An out of band communication channel that does not use the resonator or modulate the fields used for energy transfer may have a different range or effective distance than the effective or useful energy transfer range of the system. An of out-band communication channel may use or be based on Bluetooth, WiFi, Zigbee technology and the like and may be effective over several or even several hundred or more meters while the wireless energy transfer may have an effective range of several or even 30 or more

centimeters. This difference in range, performance, or capability may affect the coordination of the wireless energy transfer system.

**[00213]** For example, consider the arrangement of a wireless energy system shown in Fig. 18 comprising a two device resonators **1802, 1816** each with an out-of-band communication module **1804, 1818** respectively and two source resonators **1806, 1810** each with their own out-of-band communication modules **1808, 1812** respectively. The system may use the out-of-band communication channel to adjust and coordinate the energy transfer. The communication channel may be used to discover or find resonators in the proximity, to initiate power transfer, and to communicate adjustment of operating parameters such as power output, impedance, frequency, and the like of the individual resonators.

**[00214]** In some situations the device resonator may incorrectly communicate with one source but receive energy from another source resonator. The disparity between the energy transfer channel and the communication channel may create performance, safety, and reliability issues since the communication that is used to coordinate the energy transfer, i.e. communicate operating point adjustment of the resonators, may have no effect on the parameters of the wireless energy transfer channel.

**[00215]** In one instance a device resonator **1802** may be in close proximity with strong coupling to only one of the source resonators **1806** as shown in Fig. 18 with weak coupling to the other source resonator **1810** that is located further away from the device resonator **1802**. In some instances, due to interference, obstruction, and the like the out-of-band communication signal may be not functioning for the source **1806** and device **1802** pair with the stronger coupling between the resonators used for energy transfer than for a source **1810** and device **1802** pair with the weaker coupling between the resonators. If another device **1816** initiates wireless energy transfer with the source **1806** the device **1802** may receive power from a source in close proximity **1806** while having an out of band communication channel **1814** with a source **1810** that is further away. Any attempt by the device **1802** to adjust the energy transfer will therefore be unsuccessful since the device **1802** does not have communication with the source from which it is receiving energy.

**[00216]** Due to this disconnect between the communication and control channel and the energy transfer channel other system level reliability and control problems may develop and may lead to security and stability vulnerabilities. There may be a need for a separate verification step of the wireless energy transfer channel. As those skilled in the art will recognize the example is just but one example that illustrates the need but many

configurations and arrangements of the system may benefit from an explicitly or implicitly energy transfer verification step.

**[00217]** In embodiments, these potential problems may be avoided by providing an additional verification step that ensures that the energy transfer channel and the communication channels are used by a source or a device are associated with the same external source or device.

**[00218]** In embodiments the verification step may comprise information exchange or signaling of through the wireless energy transfer channel. A verification step comprising communication or information exchange using the energy transfer channel, or fields of the energy transfer channel may be used to verify the corresponding accuracy of the out-of-band communication channel.

**[00219]** In embodiments with an out-of-band communication channel the verification step may be implicit or explicit. In some embodiments verification may be implicit. In embodiments an energy transfer channel may be implicitly verified by monitoring and comparing the behavior of the energy transfer channel to expected behavior or parameters in response to the out-of-band information exchange. An energy transfer channel may be implicitly verified by monitoring the behavior and parameters of the energy transfer channel in response to the out-of-band communication. For example, after an out-of-band communication exchange which is expected to increase energy transfer the parameters of the wireless energy transfer channel and resonators used for the wireless energy transfer may be monitored. An observed increase of delivered power at the device may be used to infer that the out-of-band communication channel and the energy transfer channel are correctly identified.

**[00220]** In embodiments an implicit verification step may involve monitoring any number of the parameters of the wireless energy transfer or parameters of the resonators and components used in the wireless energy transfer. In embodiments the currents, voltages, impedance, frequency, efficiency, temperature, and the like may be monitored and compared to expected values, trends, changes and the like as a result of an out-of-band communication exchange.

**[00221]** In embodiments a source or a device unit may keep a table of measured parameters and expected values, trends, changes, to these parameters as a consequence of a communication exchange. A source or a device may store a history of communications and observed parameter changes that may be used to verify the energy transfer channel. In some cases a single unexpected parameter change due to a communication exchange may be not be

conclusive enough to determine is the out-of-band channel is incorrectly paired. In some embodiments the history of parameter changes may be scanned or monitored over several or many communication exchanges to perform verification.

**[00222]** An example algorithm showing the series of steps which may be used to implicitly verify an energy transfer channel in a wireless energy transfer system using out-of-band communication is shown in Fig. 19A. In the first step **1902** an out-of-band communication channel between a source and a device is established. In the next step **1904** the source and device may exchange information as regarding adjusting the parameters of the wireless energy transfer or parameters of the components used for wireless energy transfer. The information exchange on the out-of-band communication channel may be a normal exchange used in normal operation of the system to control and adjust the energy transfer. In some systems the out-of-band communication channel may be encrypted preventing eavesdropping, impersonation, and the like. In the next step **1906** the source and the device or just a source or just a device may monitor and keep track of any changes to the parameters of the wireless energy transfer or any changes in parameters in the components used in the energy transfer. The tracked changes may be compared against expected changes to the parameters as a consequence of any out-of-band communication exchanges. Validation may be considered failed when one or many observed changes in parameters do not correspond to expected changes in parameters.

**[00223]** In some embodiments of wireless energy transfer systems verification may be explicit. In embodiments a source or a device may alter, dither, modulate, and the like the parameters of the wireless energy transfer or the parameters of the resonators used in the wireless energy transfer to communicate or provide a verifiable signal to a source or device through the energy transfer channel. The explicit verification may involve changing, altering, modulating, and the like some parameters of the wireless energy transfer or the parameters of the resonators and components used in the energy transfer for the explicit purpose of verification and may not be associated with optimizing, tuning, or adjusting the energy transfer.

**[00224]** The changing, altering, modulating, and the like some parameters of the wireless energy transfer or the parameters of the resonators and components used in the energy transfer for the purpose of signaling or communicating another wireless energy resonator or component may be referred to as in-band communication. In-band communication may be characterized by its use of the fields or structures used for energy

transfer. In embodiments, the in-band communication channel may be implemented as part of the wireless energy transfer resonators and components by modulating the parameters of the magnetic fields or the resonators used for wireless energy transfer. Information may be transmitted from one resonator to another by changing the parameters of the resonators. Parameters such as inductance, impedance, resistance, and the like may be dithered or changed by one resonator. These changes in impedance may affect the impedance, resistance, or inductance of other resonators around the signaling resonator. The changes may manifest themselves as corresponding dithers of voltage, current, and the like on the resonators which may be detected and decoded into messages. In embodiments in-band communication may involve altering, changing, modulating, and the like the power level, frequency, and the like of the magnetic fields used for energy transfer.

**[00225]** In one embodiment the explicit in-band verification may be performed after an out-of-band communication channel has been established. Using the out-of-band communication channel a source and a device may exchange information as to the power transfer capabilities and in-band signaling capabilities. Wireless energy transfer between a source and a device may then be initiated. The source or device may request or challenge the other source or device to signal using the in-band communication channel to verify the connection between the out-of-band and communication channel and the energy transfer channel. The channel is verified when the agreed signaling established in the out-of-band communication channel is observed at the in-band communication channel.

**[00226]** In embodiments verification may be performed only during specific or pre-determined times of an energy protocol such as during energy transfer startup. In other embodiments explicit verification step may be performed periodically during the normal operation of the wireless energy transfer system. The verification step may be triggered when the efficiency or characteristics of the wireless power transfer change which may signal that the physical orientations have changed. In embodiments the communication controller may maintain a history of the energy transfer characteristic and initiate a verification of the transfer that includes signaling using the resonators when a change in the characteristics is observed. A change in the energy transfer characteristics may be observed in the efficiency of the energy transfer, in the impedance, voltage, current, and the like of the resonators, or components of the resonators and power and control circuitry.

**[00227]** Those skilled in the art will appreciate a signaling and communication channel capable of transmitting messages may be secured with any number of encryption,



authentication, and security algorithms. In embodiments the out-of-band communication may be encrypted and the secured communication channel may be used to transmit random sequences for verification in the in-band channel. In embodiments the in-band communication channel may be encrypted, randomized, or secured by any known security and cryptography protocols and algorithms. The security and cryptography algorithms may be used to authenticate and verify compatibility between a source and device and may use a public key infrastructure (PKI) and secondary communication channels for authorization and authentication.

**[00228]** In embodiments of energy transfer system between a source and a device a device may verify the energy transfer channel to ensure it is receiving energy from the desired or assumed source. A source may verify the energy transfer channel to ensure energy is being transferred to the desired or assumed source. In some embodiments the verification may be bidirectional and a source and device may both verify their energy transfer channels in one step or protocol operation.

**[00229]** An example algorithm showing the series of steps which may be used to explicitly verify an energy transfer channel in a wireless energy transfer system using out-of-band communication is shown in Fig. 19B. In the first step **1908** an out-of-band communication channel between a source and a device is established. In the next step **1910** the source and device may coordinate or agree on a signaling protocol, method, scheme, and the like that may be transmitted through the wireless energy transfer channel. To prevent eavesdropping and provide security the out-of-band communication channel may be encrypted and the source and device may follow any number of known cryptographic authentication protocols. In a system enabled with cryptographic protocols the verification code may comprise a challenge-response type exchange which may provide an additional level of security and authentication capability. A device, for example, may challenge the source to encrypt a random verification code which it sends to the source via the out-of-band communication channel using a shared secret encryption key or a private key. The verification code transmitted in the out-of-band communication channel may then be signaled **1912** through the in-band communication channel. In the case where the source and device are enabled with cryptographic protocols the verification code signaled in the in-band communication channel may be encrypted or modified by the sender with a reversible cryptographic function allowing the receiver to further authenticate the sender and verify that

the in-band communication channels are linked with the same source or device associated with the out-of-band communication channel.

**[00230]** In situations when the verification fails a wireless energy transfer system may try to retry validation. In some embodiments the system may try to re-validate the wireless energy transfer channel by exchanging another verification sequence for resignaling using the in-band communication channel. In some embodiments the system may change or alter the sequence or type of information that is used to verify the in-band communication channel after attempts to verify the in-band communication channel have failed. The system may change the type of signaling, protocol, length, complexity and the like of the in-band communication verification code.

**[00231]** In some embodiments, upon failure of verification of the in-band communication channel and hence the energy transfer channel, the system may adjust the power level, the strength of modulation, frequency of modulation and the like of the signaling method in the in-band communication channel. For example, upon failure of verification of a source by a device the system may attempt to perform the verification at a higher energy transfer level. The system may increase the power output of the source generating stronger magnetic fields. In another example, upon failure of verification of a source by a device the source that communicated the verification code to the device by changing the impedance of its source resonator may increase or even double the amount of change in the impedance of the source resonator for the signaling.

**[00232]** In embodiments upon failure of verification of the energy transfer channel the system may try to probe, find, or discover other possible sources or devices using the out-of-band communication channel. In embodiments the out-of-band communication channel may be used to find other possible candidates for wireless energy transfer. In some embodiments the system may change or adjust the output power or the range of the out-of-band communication channel to help minimize false pairings.

**[00233]** The out-of-band communication channel may be power modulated to have several modes, long range mode to detect sources and a short range or low power mode to ensure the communication is with another device or source that is in close proximity. In embodiments the out-of-band communication channel may be matched to the range of the wireless channel for each application. After failure of verification of the energy transfer channel the output power of the out-of-band communication channel may be slowly increased to find other possible sources or devices for wireless energy transfer. As discussed above, an

out-of-band communication channel may exhibit interferences and obstructions that may be different from the interferences and obstructions of the energy transfer channel and sources and devices that may require higher power levels for out-of-band communication may be in close enough proximity to allow wireless energy transfer.

**[00234]** In some embodiments the out-of-band communication channel may be directed, arranged, focused using shielding or positioning to be only effective in a confined area (i.e., under a vehicle). to ensure it is only capable of establishing communication with another source or device that is in close enough proximity, position, and orientation for energy transfer.

**[00235]** In embodiments the system may use one or more supplemental sources of information to establish an out-of-band communication channel or to verify an in-band energy transfer channel. For example, during initial establishment of an out-of-band communication channel the locations of the sources or devices may be compared to known or mapped locations or a database of locations of wireless sources or devices to determine the most probable pair for successful energy transfer. Out-of-band communication channel discovery may be supplemented with GPS data from a GPS receiver, data from positioning sensors and the like.

**[00236] Photovoltaic (PV) Panels with Wireless Energy Transfer**

**[00237]** We describe a system that may use a source resonator, and a capture resonator, to wirelessly transfer power from an exterior solar PV panel to an interior capture module or to other solar PV panels. In embodiments a solar PV panel has one or more resonators that transfer the solar generated power from the solar PV panel to one or more resonators that may be part of another solar PV panel, or may be inside a building, vehicle, boat, and the like, or part of a mounting structure of the panel.

**[00238]** In embodiments one or more resonators may be integrated into the solar PV panel assembly. Resonators may be integrated into the perimeter of the panel or they may be designed to fit under the photovoltaic element of the panel. The resonators may be designed and oriented to generate a magnetic field that is substantially perpendicular to the plane of the PV panel to allow efficient coupling with resonators that may be placed behind the panel. In embodiments the integrated resonators in the PV panel may be designed and positioned such that the magnetic field is substantially parallel to the surface of the panel allowing efficient coupling with like resonators that are on the sides of the panel. In other embodiments resonators may be designed and oriented to generate a magnetic field that is substantially

omnidirectional. In embodiments with integrated resonators, no physical or direct electrical contacts are required.

**[00239]** Figure 20 shows a diagram of a rectangular PV panel **2002** with outlines of three integrated resonators showing several possible resonator orientations and locations. A resonator may be integrated into the perimeter **2001** of the panel. Resonators may be placed inside the or behind the PV panel in any location **2003** and may have various sizes and orientations such as the resonator **2004** which is oriented such that the magnetic field is directed out of the corner of the panel. Although not shown in the figure, the resonators may include appropriate shielding and magnetic field guides to reduce perturbations and losses from the resonators.

**[00240]** In embodiments a resonator of the PV panel may be outside of the main panel body assembly. A cable or a wired connector may attach the PV panel to the resonator. In this embodiment the location and orientation of the resonator may be chosen and altered independently of the position of the PV panel and may allow more flexibility in mounting and positioning of the system. In this embodiment the resonator of the PV panel may be aligned with the receiving resonator without having to move the PV panel. Figure 21 shows an embodiment of a PV panel **2103** with an external resonator **2101** that is wired **2102** to the PV panel.

**[00241]** In embodiments a PV panel may contain more than one resonator. A PV panel may contain one or more internal resonators and may have one or more external resonators. The resonators may be aligned and positioned in different orientations to allow energy transfer to resonators placed in various orientations and positions relative to the PV panel. In embodiments multiple resonators of the PV panel may be used simultaneously to transfer and receive power from other resonators. For example, one resonator of a PV panel may be used to receive power from another PV panel and use one of its other resonators to transfer power to a device or a resonator inside a building. A PV panel system may employ various panel designs each with possibly different resonator configurations.

**[00242]** In panels with integrated resonators the panels may not require any holes, feedthroughs, wiring, or connectors. Electronics that control the PV panel and the resonators may all be integrated into the panel. The panel can thus be made completely enclosed and waterproof providing complete protection against moisture, dust, dirt, insects, and the like. In some embodiments the enclosure of the PV panel may preferably be composed partially or completely of magnetically permeable materials to allow efficient magnetic coupling and

minimize losses in the energy transfer. In some embodiments, magnets may be used to hold PV panels comprising magnetically permeable materials in place. The PV panels may be of any size, shape, and dimension and are not limited to the geometries pictured. Resonators and PV panels may be of any geometry, for example they may be shaped to follow the contours of a vehicle. Resonators and PV panels may be flexible or hinged and may be designed such that they can be rolled into a tube or folded when not in use.

**[00243]** In accordance with the present invention power may be wirelessly transferred from the PV panel resonators to resonators powering devices or to resonators that are coupled to the electrical network of a building, vehicle, and the like.

**[00244]** In one embodiment, PV panels with resonators may be used to directly and wirelessly power devices. Devices capable of coupling to the magnetic resonators of the PV panels can wirelessly receive energy to power their electronics or recharge batteries. Device resonators can be tuned to couple to the resonators of the PV panels. PV panels with integrated or external resonators for wireless power transfer may be deployed in many environments and applications. The PV panel may be attached or placed either permanently or temporarily on vehicles, buildings, tool boxes, planes, and other structures to provide wireless power from solar energy. With wireless power transfer no wiring is required to connect devices to the PV panel and hence the PV panel can be easily installed or placed in areas that require power.

**[00245]** For example, as shown in Figure 22 a PV panel with the described wireless power transfer resonators may be attached to the roof **2202**, trunk **2203**, side panel **2204**, or hood **2201** of a vehicle. The energy from the PV panel may be wirelessly transferred through the roof, trunk, side panel, or hood of the vehicle by the resonator of the PV panel into the vehicle to power or charge electronics within the vehicle. Devices with resonators can directly couple to the resonator of the PV panel and receive power. Devices such as mobile handsets, laptops, gaming consoles, GPS devices, electric tools, and the like can be charged or power wirelessly by energy derived from solar power despite the devices being in a dark, enclosed space of a vehicle without requiring wiring. PV panels with wireless power transfer may be attached to the top or above the bed of a pick-up truck for example, allowing wireless charging of batteries or battery powered tools that may be stored in the back of the truck.

**[00246]** In another example, PV panels may be mounted on the exterior of a car. A capture resonator inside the vehicle, under the roof, the hood, or the trunk of the vehicle that is coupled to the electrical system of the vehicle can capture the energy from the resonator of

the PV panel. The solar energy can be used to power the vehicle, recharge batteries, or power other peripherals of the vehicle. With wireless power transfer the PV panels can be installed or retrofitted to the vehicle without having to make any hard-wired connections between the panel and the vehicle simplifying the installation and allowing quick removal if necessary.

**[00247]** In another example, PV panels with wireless power transmission may be integrated into the top of an awning or a sun umbrella as shown in Figure 23. PV panels on top of an umbrella **2303, 2304, 2305, 2306** with internal or external resonators may transfer power to enabled devices such as laptops **2302** or mobile handsets **2301** that are located the shade below the umbrella or awning.

**[00248]** In other embodiments, PV panels with wireless power transfer may be used transfer power to a resonator that is directly coupled to a wired power distribution or electrical system of a house, vehicle, and the like without requiring any direct contact between the exterior PV panels and the internal electrical system. For example, a solar PV panel with the above described resonators may be mounted directly onto the exterior of a building, vehicle, and the like. A resonator may be mounted inside the building, vehicle, and the like which can be connected to the electrical system of the structure. The resonator on the interior can receive power from the PV panels on the exterior and transfer the energy to the electrical system of the structure allowing powering of devices connected to the power system. In embodiments, the power received by the resonator from the PV panels can be conditioned in a way that allows it to be transferred to the electrical grid. For example, one or more capture resonators may provide electrical power to an inverter, said inverter then providing power to the electrical grid.

**[00249]** For example, as shown in a diagram in Figure 24, PV panels with wireless power transfer may be mounted on the exterior roof of a building. A resonator that is coupled to the electrical system of the building may be mounted on the interior underside of the roof behind the PV panel. Power may be transferred from the exterior PV panel to the interior electrical system of the building without requiring any drilling or penetration of the exterior of the building for wiring. Solar power from the PV panels may then be utilized by electric devices connected to the wired electrical system of the building. Captured electrical energy from the PV panels may also be provided to a breaker panel which may be attached to the electrical grid.

[00250] PV panels with wireless power transfer may simplify installation and connection of multiple PV panels. Wireless power transfer may be utilized for connection and capture power from several PV panels that may be part of a system.

[00251] In one embodiment with multiple PV panels, each panel may have one or more resonators that transmit power to a device or to a corresponding resonator that is coupled to a wired electric system. PV panels placed on the exterior roof of a building, for example, may each have a corresponding capture resonator on the interior of the building that is coupled to electrical system. PV panels placed on the exterior of a car, for example, may each power couple to various device resonators inside the vehicle. In such embodiments each PV panel is independent of other PV panels. A diagram of an example rooftop configuration of such a system is shown in Figure 25. Each PV panel **2502** in the figure has resonators **2503** that can transmit energy directly through the roof **2501** to a resonator mounted inside the building (not shown).

[00252] In another embodiment with multiple PV panels, the panels may utilize wireless power transfer between each other to transfer or collect power to/from one or more of designated panels. In this embodiment only a few designated panels are able to transmit power to devices or resonators that are coupled to an electrical system. The energy is gathered and transmitted in one or several points. In such embodiments adjacent PV panels are dependent on each other, but may be easily installed or replaced when faulty since no wiring between panels or electrical system is required. A diagram of an example rooftop configuration of such a system is shown in Figure 26. One or more panels **2606** have resonators **2605** that can transfer energy to a resonator inside the building. Energy from other resonators may be transferred wirelessly from panel to panel until it reaches the panel that is capable of transmitting the energy into the building. For example in Figure 26, panel **2601** may transfer energy to its adjacent panel **2602** via their coupled resonators **2607, 2608**. Likewise panel **2602** may transfer its energy and the energy from panel **2601** to panel **2606** via coupled resonators **2603, 2604**. Panel **2606** may then transfer the energy originating from panels **2601, 2602, 2606** to a resonator inside the building (not shown).

[00253] In another embodiment with multiple PV panels, an additional connection structure that wirelessly receives power from multiple panels can be used. A structure of resonators may be mounted into a mounting strip that is placed beneath or next to PV panels. Resonators of the PV panel may wirelessly transfer their energy to the resonators on the strip. One or a few resonators connected to the strip can be used to transfer the power from all the

panels to devices or to an interior resonator coupled to an electronic system. In such a system, once a resonator strip is installed panels may be removed or added to the system by securing the panels on or near the connection structure. A diagram of an example rooftop configuration of such a system is shown in Figure 27. A structure of resonators **2702**, shaped as a flat elongated strip may be attached to the roof of a building. A PV panel **2701** with a resonator **2703** may transfer energy to the strip. The strip may then use a single resonator **2705** that is coupled to a resonator inside the building (not shown) to transfer the energy of all the panels to the interior without any wires. A panel may be added or removed from the system by simply placing the panel on top of the strip.

**[00254]** In yet another embodiment multiple panels can be physically wired together to a resonator that can transmit their power wirelessly to devices wired or coupled to other resonators on the interior of a building or vehicle.

**[00255]** With all of the above configurations using wireless power transfer, significantly simpler installation of PV panels is possible because power may be transmitted wirelessly from the panel to a capture resonator in the building or vehicle, eliminating all outside wiring, connectors, and conduits, and any holes through the roof or walls of the structure. Wireless power transfer used with solar cells may have a benefit in that it can reduced roof danger since it eliminates the need for electricians to work on the roof to interconnect panels, strings, and junction boxes. Installation of solar panels integrated with wireless power transfer may require less skilled labor since fewer electrical contacts need to be made. Less site specific design may be required with wireless power transfer since the technology gives the installer the ability to individually optimize and position each solar PV panel, significantly reducing the need for expensive engineering and panel layout services.

**[00256]** With wireless power transfer, PV panels may be deployed temporarily, and then moved or removed, without leaving behind permanent alterations to the surrounding structures. They may be placed out in a yard on sunny days, and moved around to follow the sun, or brought inside for cleaning or storage, for example. For backyard or mobile solar PV applications, an extension cord with a wireless energy capture device may be thrown on the ground or placed near the solar unit. The capture extension cord can be completely sealed from the elements and electrically isolated, so that it may be used in any indoor or outdoor environment.

**[00257]** With wireless power transfer no wires or external connections may be necessary to the PV solar panels and they can be completely weather sealed. Significantly



improved reliability and lifetime of electrical components in the solar PV power generation and transmission circuitry can be expected since the weather-sealed enclosures can protect components from UV radiation, humidity, weather, dust, and the like. With wireless power transfer and weather-sealed enclosures it may be possible to use less expensive components since they will no longer be directly exposed to external factors and weather elements and it may reduce the cost of PV panels. Likewise PV panels with wireless power transfer can be more generic and more portable since the PV panels do not require a fixed hardwired connection.

**[00258]** In embodiments power transfer between the PV panels and the capture resonators inside a building or a vehicle may be bidirectional. Energy may be transmitted from the house grid to the PV panels to provide power when the panels do not have enough energy for self calibration, alignment, or maintenance tasks. Reverse power flow can be used to power heating elements that can melt snow from the panels, or power motors that will position the panels in a more favorable position with respect to the light source. Once the snow is melted or the panels are repositioned energy can be transfer from the PV panels.

**[00259]** In some embodiments, the source electronics that are coupled to the source resonator may comprise at least one half-bridge or full-bridge switching amplifier. The capture electronics that are coupled to the capture resonator may comprise at least one half-bridge or full-bridge rectifier further comprising power transistors. These embodiments allow wireless power transfer from an energy source connected to the source electronics to be delivered to a load connected to the capture electronics. Note that both the source and capture electronics employ half-bridge or full-bridge switching circuits. Therefore, these embodiments also allow wireless power transfer in the reverse direction where an energy source that is connected to the capture electronics can transfer energy to a load connected to the source electronics. This enables, for example, transferring and retrieving energy wirelessly from an energy storage medium such as a battery, fly wheel, capacitor, inductor, and the like. It also enables reverse power flow to a wirelessly enabled PV panel for melting snow, as described above.

**[00260]** The resonators and the wireless power transfer circuitry may include tuning and safety mechanisms. In embodiments PV panels with wireless power transfer may include auto-tuning on installation to ensure maximum and efficient power transfer to the wireless collector. For example, variations in roofing materials or variations in distances between the PV panels and the wireless power collector in different installations may affect

the performance or perturb the properties of the resonators of the wireless power transfer. To reduce the installation complexity the wireless power transfer components may include a tuning capability to automatically adjust their operating point to compensate for any effects due to materials or distance. Frequency, impedance, capacitance, inductance, duty cycle, voltage levels and the like may be adjusted to ensure efficient and safe power transfer.

**[00261]** The resonators and wireless power transfer circuitry may include tuning that ensures maximum power extraction from the PV panels as well as efficient wireless transfer of the extracted power. In embodiments, the wireless power transfer circuitry may be configured for energy transfer between resonators while also applying an equivalent load resistance to a PV panel for optimal energy extraction. Such a wireless source can efficiently transfer energy from a PV panel to a wireless capture device over a wider range of environmental conditions than is currently possible. For example, as the solar illumination level (or equivalently irradiance) increases during the morning, the impedance applied to the output of the PV panel would decrease in a manner that maximizes power extraction from the PV panel. Such a wireless energy source is referred to herein as a “wireless energy maximum power point tracker (WEMPPT).” For example, Figure 28A depicts a solar panel comprising a plurality of photovoltaic junctions connected in series. For simplicity, each photovoltaic junction is represented by the parallel combination of a current source and a diode. A more realistic model would include series and shunt resistances, diode variations, and the like. The voltage  $V$  and current  $I$  generated by the panel depend, in part, on the solar irradiance, and on the equivalent resistance  $R$  presented to the output of the panel. Figure 28B shows several exemplary curves for parametric variation of  $R$  and different solar illumination levels. Also depicted in Figure 28B are the points on the curves where the maximum power can be extracted from the PV panel by a given load resistance  $R$ . This is the value of  $R$  that a maximum power point tracker (MPPT) should present to the panel.

**[00262]** For the circuit model depicted in Figure 28A, the current flowing into the resistance  $R$  is  $I_{solar} - I_s(e^{\frac{V}{NV_{th}}} - 1)$ , where  $I_{solar}$  is the solar-generated current,  $V$  is the voltage across the panel,  $N$  is the number of cells in the panel,  $I_s$  is the reverse saturation current, and  $V_{th}$  is approximately 0.026 V at a temperature of 25C. The power extracted from the panel that can be wirelessly transferred is simply  $V \times I_{solar}$ . The root of the derivative of power with respect to  $V$ , results in the maximum power point voltage:

$$V_{MPPT} = NV_{th} [ W(e(I_{solar} + I_s)/I_s) - 1 ], \quad (4)$$

where  $W(z)$  is the Lambert W-function or product-log function, defined by inverse function for  $z = W(z) e^{W(z)}$ . Fig. 29 shows a plot of the maximum power point voltage as a function of the PV panel or array current. For this example, the resistance for maximum power that should be presented by the WEMPPT to the PV panel is the slope of the curve shown in Fig. 29. Fig. 30 shows this resistance and how it varies with solar illumination for an exemplary panel with 60 cells,  $1 \text{ m}^2$  area, and room temperature operation. For example, with  $1 \text{ kW/m}^2$  irradiance, the array current would be approximately 8 A and the optimum resistance would be  $4 \Omega$ . If the irradiance were to drop to  $0.2 \text{ kW/m}^2$  then the optimum resistance would be  $12.5 \Omega$ . In one embodiment, a wireless power source may only present a fixed resistance to the PV panel. A loss of efficiency may then occur. For the example above, the efficiency at  $0.2 \text{ kW/m}^2$  irradiance would be more than a factor of four lower than for  $1 \text{ kW/m}^2$ —which would result in more than a factor of 20 reduction in extracted power. In another embodiment, using the WEMPPT configuration would preserve the efficiency for the irradiances in the example so that the extracted power is substantially proportional to the solar irradiance.

**[00263]** In embodiments, a wireless energy source can be connected to the output of a conventional MPPT circuit that may include a DC-to-DC converter and that is connected to a PV panel. Fig. 31A shows one such embodiment. In this embodiment loss of system efficiency may occur because of power dissipation in both the MPPT circuit and the wireless energy source. Figure 31B shows a more efficient embodiment where a wireless energy source can mimic the behavior of a separate MPPT circuit without incurring the additional efficiency loss of a separate MPPT circuit. Figure 31C shows another embodiment where a wireless energy capture circuit provides efficient wireless energy capture as well as a controlled output level of current or voltage. In embodiments, such a circuit, labeled “Rectifier with DC current or voltage conversion” in Fig. 31 C, can be realized with a half-bridge or full-bridge switching circuit. In embodiments, the rectifier adjusts the duty cycle and/or the phase angle of the PWM waveform in the device (and/or the source) to affect wireless energy capture and voltage or current regulation. The rectifier may also adjust the switching times of the switches relative to the oscillating current flowing through the device resonator to efficiently capture wireless energy and also maintain voltage or current control.

**[00264]** PV panels with WEMPPTs may simplify installation of strings of panels where different panels in the string experience different levels of irradiance or different environmental conditions. Strings of series-connected PV panels are useful for developing

higher output voltage than a single panel can provide. A high output voltage may be more compatible with load devices such as grid-tied inverters, off-grid inverters, charge controllers for battery chargers, and the like. In embodiments, a plurality of PV panels, each with an associated WEMPPT, may be placed on a roof top or other external surface and exposed to illumination of varying levels between panels. Under the roof or at the internal surface, a plurality of energy capture devices may receive wireless energy from the sources and have their outputs combined. Fig. 32 depicts an embodiment where the outputs of device resonators **3224, 3226, 3228, 3230, 3232** receiving wireless energy from source resonators of the PV cells **3202, 3204, 3206, 3208, 3210** are combined into a string under the roof. In embodiments, the outputs of the capture devices are combined in series to boost the net voltage. In embodiments, the capture devices include current or voltage regulation **3212, 3214, 3216, 3218, 3220** and their outputs are combined in series to create a higher voltage with a regulated current or voltage **3222**. In embodiments, the capture devices include current or voltage regulation **3212, 3214, 3216, 3218, 3220** and their output are combined in parallel to create a higher current with a regulated current or voltage **3222**.

**[00265]** In embodiments, WEMPPT configuration may be realized in a wireless energy source comprising a switching amplifier with automatic adjustment of the phase angle of the switching times for the transistors in the amplifier. The relationship in time between when the switches are opened and when the current flowing through the switches changes direction is what determines one phase angle, herein referred to as  $\phi$ . Another phase angle, herein referred to as  $\gamma$ , describes the relationship between when the diodes shunting the switches conduct and when the switches are closed. This provides two degrees of freedom for adjusting the characteristics of the energy source in a way that is advantageous both for energy extraction from a PV panel, and for efficient wireless transmission of said extracted energy. More specifically, the amplifier depicted in Fig. 33 can present an optimum resistance  $R_{dc}$  to the PV panel while simultaneously presenting a substantially matched AC output impedance to the impedance matching network (IMN). This allows the extracted energy to be efficiently transferred through the source loop to the device loop and through the device IMN and to the rectifier.

**[00266]** Fig. 34 shows an example of a half-bridge amplifier that can be used to provide an optimum resistance  $R_{dc}$  to a PV panel. Exemplary waveforms for such an amplifier are depicted in Figs. 35A and 35B for two different timing configurations for operating switches S1 and S2. Fig. 35A shows an example of a timing configuration for

realizing high-efficiency AC waveforms. Note how the switch S1 is closed at the precise moment when the current  $i_{ac}$  changes sign and also when the voltage  $v_{ac}$  reaches  $V_{dc}/2$ . While closing, the switch S1 is said to experience zero-current and zero-voltage switching. A short time before, defined as  $\phi/\omega$ , the switch S2 was opened and experienced zero-voltage switching. A half-period after S2 was opened, S1 opens and also experiences zero-voltage switching. These conditions result in nearly zero dissipation in the switches. The high-efficiency switching can be realized for different designs with various values of  $\phi/\omega$ , while providing a degree of freedom for impedance matching to various ac loads for wireless energy transmission. An additional degree of freedom is needed to adjust the dc resistance presented to the PV panel. One such degree of freedom is depicted in Fig. 35B which shows how S2 can be opened slightly earlier than depicted in Fig. 35A. The value of  $v_{ac}$  then reaches  $V_{dc}/2$  before S1 closes and the current  $i_{ac}$  then flows through the diode D1 (turning it on) until the current crosses zero. The diode D1 stays on for a time  $\gamma/\omega$  at which time the switch S1 closes under a nearly zero-voltage condition. Note that zero-current switching is sacrificed, although near-zero-voltage switching is preserved because of the diodes. This still results in high-efficiency operation. Adjusting the value of  $\gamma/\omega$  provides an additional degree of freedom for adjusting the dc resistance presented to the PV panel. Fig. 36 shows a specific example of how the dc resistance can be changed by a factor of 4 by adjusting the value of the phase  $\gamma$  for a fixed value of the phase  $\phi$ . For the circuit depicted in Fig. 34, an equation that relates the dc resistance to the phase  $\gamma$  can be written as

$$R_{dc} = (2\pi/\omega C)(\cos \gamma - \cos(\gamma + \phi))/(\cos \gamma + \cos(\gamma + \phi)). \quad (5)$$

As the phase  $\gamma$  is adjusted, the AC output impedance of the amplifier changes as well. Fig. 37A shows the dependence of the output impedance on the phase  $\phi$ . Fig. 37B shows how the output impedance additionally depends on the phase  $\gamma$ . In embodiments, phases  $\phi$  and  $\gamma$  are chosen in combinations that optimize  $R_{dc}$  presented to the PV panel as well as the AC impedance presented to the impedance matching network. In embodiments, the phase  $\gamma$  is adjusted in combination with circuit elements such as capacitors, inductors, and resistors in the impedance matching network to optimize  $R_{dc}$  presented to the PV panel as well as the AC impedance presented to the source resonator.

**[00267]** In other embodiments, WEMPPT configurations may be realized in a wireless energy source comprising circuit elements such as capacitors, inductors, and resistors by adding automatic adjustment of said circuit elements in response to changing environmental conditions. Said circuit elements may be part of any of the amplifier, impedance matching

network, and/or resonator. In other embodiments, WEMPPT configurations may include circuit elements that can be tuned as well as switching times for the transistors that can be adjusted. Fig. 38 depicts one exemplary embodiment with a master control algorithm. The master control algorithm evaluates inputs such as the current and voltage waveforms flowing through the impedance matching network and source coil combination. The algorithm uses processing of said inputs to determine, for example, a more optimal DC impedance to present to the PV cell and/or a more favorable AC impedance to present to the impedance matching network. The algorithm controls a means of adjusting the PWM waveform and/or a means of adjusting a tuning network so that the more optimal impedances may be realized.

**[00268]** Fig. 39 depicts an exemplary embodiment of a control algorithm. For a time-step  $n$ , the algorithm measures the AC voltage and current across the impedance matching network. The algorithm also measures the DC voltage across the PV panel. The algorithm then calculates a new setpoint for a tunable capacitance in the tuning network and actuates the change. The voltages and currents are remeasured in a next time-step and the adjustment loop continues until the desired capacitance state is achieved. Next, the power extracted from the PV panel is compared to the power extracted in the previous time-step and the sign of the difference is computed. The sign of the difference then determines how the algorithm adjusts the duty cycle of the switching times of the transistor switches. The duty cycle may be adjusted by changing either of the phase angles  $\phi$  or  $\gamma$ , as described above.

**[00269]** In addition to solar PV panels, other methods of generating electrical energy include wind-powered generators, water-powered generators, thermoelectric generators, thermophotovoltaic generators, and the like. Such methods also provide electrical output that varies with environmental conditions, and conventional MPPT circuits can be used to maximize energy extraction. Those skilled in the art will understand that the features of the WEMPPT configuration are general and may be applied to a wide range of electrical energy generators.

**[00270]** In embodiments the wireless power transfer system may include safety interlocks and sensors. The PV panels and resonators may include temperature, power, impedance, and voltage sensors and microcontrollers or processors to ensure the panel operates within allowable limits. The wireless power transfer system may include a ground connection to provide a discharge path for accumulated electric charge. The wireless power transfer system may include a voltage sensor that enables detection of accumulated electric charge. If no connection to earth ground is available to the PV panel with wireless power

transfer, the panel may include a ground-fault interrupt sensor where the case of the PV panel is treated as ground.

**[00271]** In embodiments the PV panels and resonators may include sensors and visual, auditory, and vibrational feedback to aid in resonator alignment to ensure efficient power transfer between an external PV panel and an internal capture resonator. For example, one of the resonators may be used to sense the position of another resonator by sensing an increase or decrease in the resonant coupling between the resonators. Alternatively, an increase or decrease in the mutual inductance between the resonators may be used to determine relative position of the resonators.

**[00272]** In embodiments with multiple PV panels or multiple resonators, the resonators of the system may be tuned to different frequencies to avoid interference. The tuned frequency of the various resonators may be time or frequency multiplexed. In other embodiments, the source and capture resonators may include a communications capability that allows the source and capture resonators to exchange configuration information. In other embodiments, such source and capture resonators may exchange information needed for initial calibration or for verifying that exchange of power is occurring between the intended resonators. The communication can be in-band or out-of-band, as was described above.

**[00273]** Fig. 40 shows a preferred embodiment of the WEMPPT configuration for the example of a solar PV panel installed on the roof of a building. A PV panel is depicted at left as a series-connected plurality of solar cells, where each cell is represented by a simplified equivalent circuit comprising a current source and a diode, as described above. The capacitor represents the capacitance across the PV panel terminals. Next, the PV panel terminals are connected to a full-bridge switching amplifier that can operate in the class DE mode described above. The switching times for S1-S4 and related parameters such as duty cycle and the phase angles  $\phi$  and  $\gamma$  can be adjusted by a source controller. Next, the AC outputs of the switching amplifier are connected to an impedance matching network (IMN) with an adjustable circuit element such as a capacitor. As described herein, the combination of the switching time parameters and the circuit element can be adjusted in a manner that optimizes both the extraction of power from the PV panel and the wireless transfer of power through the roof barrier for a variety of environmental and solar irradiance conditions. A preferred algorithm for making the adjustments uses measured values of at least one of the DC current and DC voltage from the PV panel as well as measured values of at least one of the AC current and AC voltage in the IMN or on the source coil.

[00274] The right side of Figure 40 shows the configuration of the power capture part of the WEMPPT configuration—interior to the building in this example. An algorithm can be implemented in a capture controller that performs two functions. First, said controller optimizes the impedance matching of the capture coil to the rectifier. Second, said controller regulates the DC current, DC voltage, and/or power output from the rectifier. A preferred algorithm for the roof-top solar example measures at least one of the AC current and AC voltage from the capture coil and at least one of the DC voltage or DC current from the rectifier. The switching times for S5-S8 can then be adjusted to maintain high-efficiency rectification. When coupled with another adjustable parameter such as a variable capacitor in the IMN, the switching times and the variable capacitor can be adjusted to optimize impedance matching, maintain high-efficiency rectification, and regulate the output DC current or voltage or power from the rectifier.

[00275] In a preferred embodiment for the example of a plurality of PV panels on a roof, each PV panel may have a corresponding capture circuit where each capture circuit regulates its DC output current to a common value  $I_{dc}$ . Then the plurality of PV panels can be electrically connected in series, as depicted in Figure 41. Each PV panel may develop a voltage  $V_{dc_i}$ , where  $i$  is an index corresponding to the  $i$ th PV panel. When different PV panels experience different irradiance, their power capture circuits may develop different DC voltages at the common current value of  $I_{dc}$ . The sum of the different DC voltages,  $V_{string}$ , is available to an inverter or battery charger. The amount of power supplied to the inverter or charger is  $P = V_{string} \times I_{dc}$ . For a given amount of power from the panels  $P$ , the value of  $V_{string}$  is determined by the value of  $I_{dc}$  flowing through the series-connected capture circuits. This is advantageous to maintaining a near-constant value of  $V_{string}$  at the input of the inverter or charger—a condition that allows the inverter or charger to operate near its peak efficiency. To realize a near-constant  $V_{string}$ , the inverter or charger may set the common current value  $I_{dc}$  for each of the power capture circuits. A communications link could be established between the inverter or charger and the power capture circuits to set the common current value. The link could make use of the DC wiring or it could use wireless communications.

[00276] The communications link could also be used to communicate information of diagnostic, performance, or other status information between the inverter or charger and the power capture circuits. It is also possible for each of the power capture circuits to obtain information about its corresponding PV panel using either in-band or out-of-band communications as described above. The information about the PV panels can then be shared



across the interior communications link. This could include information about the relative alignment of a power capture circuit with its corresponding PV panel. The relative alignment could be monitored from the power capture circuit by a variety of techniques including inductive sensing, magnetic field-strength sensing, capacitive sensing, thermal sensing, or other modalities that do not require roof penetrations. In a preferred embodiment, relative alignment is monitored with a method that is sensitive to the mutual inductive coupling between the source and capture coils.

[00277] Although described in the context of solar PV panels, one skilled in the art will appreciate that the techniques and methods described may be used with other energy harvesting devices such as wind turbines, water turbines, thermal exchangers, and the like. An energy producing wind turbine mounted on the roof of a building, for example, may benefit from wireless power transfer in a similar way as described for the PV panels. Because other energy harvesting devices vary depending on environmental conditions, the WEMPPT functionality described above may be used in embodiments other than PV panels. Power from the wind turbine may be transferred from the exterior to the interior of the building without having to make holes or penetrations in the roof or walls. Likewise water turbines in boats or other structures that use water motion like currents, waves, and the like to generate energy may benefit from wireless power transfer. Drilling for wiring through a hull of a boat or a sealed submerged structure is undesirable for such applications. With wireless power transmission, submerged turbines and energy harvesters may be completely sealed and isolated making such devices more reliable and also easier to replace or repair since they can be removed and replaced without requiring any resealing of connections.

[00278] **Wireless Energy Transfer for Packaging**

[00279] Wireless energy transfer may be used to transfer energy to product packaging, packaged products, and the like. Power may be transferred to packaging or packaged products when the packages are on the shelves in a retail environment, in a storage environment, in a warehouse environment, in a refrigerator environment, in a shipping environment, and the like. Wireless energy captured by a package may be used to illuminate parts of the packaging, power electronics or sensors or the packaging, control the temperature of the packaging, provide power to devices or batteries inside the packaging, provide power to displays on the packaging, and the like.

[00280] Product packaging may include boxes, bags, bottles, stickers, cartons, displays, wrappings, bottle caps, signs, flyers, attachments, and the like. Product packaging

may be a disposable outer wrapper of a product that gets removed before use. Product packaging may mean an integral part of the product which does not get removed but is a permanent part of the product.

**[00281]** In accordance with exemplary and non-limiting embodiments, a device resonator and electronics may be integrated into the packaging, may be located on the inside of the packaging, or attached to the outside of the packaging and receive wireless energy from a source resonator located on a shelf, on a floor, in a ceiling, in a wall, and the like at a position to transfer energy from the source resonator to the device resonator.

**[00282]** In accordance with exemplary and non-limiting embodiments the energy captured by the device resonator may be used to energize lights, buzzers, motors, vibrators, displays, organic materials, conductive inks or paints, or any other visual, auditory, or tactile stimulator that may be used to enhance a product's appearance, to convey information, or to attract the attention of a consumer.

**[00283]** In accordance with exemplary and non-limiting embodiments, the energy captured by the device resonator may be used directly by the packaged product. Energy may be used to recharge the battery of the packaged device ensuring that when the device is purchased and unpacked the battery of the device will be sufficiently charged for immediate use.

**[00284]** In accordance with exemplary and non-limiting embodiments, the energy captured by the device resonator may be used to maintain or monitor the environmental conditions within the packaging. Parameters such as temperature, light, humidity, product freshness, product quality, packaging integrity, and the like may be monitored, recorded, and reported to a user or a consumer.

**[00285]** One exemplary embodiment of product packaging with a wireless energy transfer system is depicted in Fig. 42. A package **4202** with an integrated device resonator **4208** and optional device electronics (not pictured) may be placed near a source resonator **4204** coupled to source electronics (not pictured). The energy captured by the device resonator may be used to energize a light emitting feature **4210** of the packaging via a wired **4206** electrical connection. In embodiments the light emitting feature may be an LED, a bulb, a fluorescent bulb, a light emitting paint, a part of a display, and the like, that may be directly attached, integrated and/or recessed in the packaging.

**[00286]** In accordance with exemplary and non-limiting embodiments, the source and device resonators **4204**, **4208** may be of different sizes. In accordance with exemplary and

non-limiting embodiments, it may be preferable to have the source resonator **4204** be larger than the device resonator **4208** to allow a greater freedom of movement and placement of the device resonator **4208** within the proximity of the source resonator **4204**.

[00287] In accordance with exemplary and non-limiting embodiments, the source and device resonators **4204**, **4208** may be of any resonator type described herein and may include a planar resonator, a printed circuit board resonator, and the like. In exemplary embodiments the coil of the resonators **4204**, **4206** may be comprise an electrical conductor printed directly onto the packaging or onto an insert or a sticker that is attached to the packaging.

[00288] In accordance with exemplary and non-limiting embodiments, the device resonators **4208** may be adapted to fit into different sides and faces of the packaging. In accordance with exemplary and non-limiting embodiments, the device resonators **4208** may be adapted to fit round packaging such as depicted in Fig. 43 where a resonator coil **4316** is fitted around the perimeter of a cylindrical package **4314** and powers a illuminated logo **4312** of the package.

[00289] In embodiments the packaged products may be stacked or arranged in configurations where some packaged products may not be directly next to a source resonator **4204** but may be separated from a source resonator **4204** by one or more other packages or products. To receive energy the packaged products may need to receive energy through one or more packaged products. For example, as depicted in Fig. 44 square packages **4422** may be stacked in a three dimensional array on a shelf. The array may be four or more packages deep in all the directions. As a result, a source resonator **4204** placed on the top, back **4424**, or bottom **4426** of the shelf **4428** may not be in contact or close proximity to all of the packages in the array so as to provide energy to device resonators **4208** corresponding to each of the packages **4422**.

[00290] In accordance with exemplary and non-limiting embodiments, the maximum dimensions and distances of a stack or array of products may be limited based on the sizes of resonators, the power output from the source resonator, and the power requirements of the products. A package may be rated for a maximum separation from the source and hence a maximum stacking height.

[00291] In accordance with exemplary and non-limiting embodiments, the stacking height or separation distance of the source and the devices may be increased with repeater resonators. Large repeater resonators may be placed in between layers of stacked packaging increasing the coupling strength of the resonators in the devices and the source. For example,

for the configuration shown in Fig. 44, energized by the bottom source resonator **4426**, a large repeater resonator **4430** may be inserted between the first and the second layer of packages to extend the wireless energy transfer range to, for example, the second or third row of packages. A repeater resonator **4430** may also be inserted between the second and third rows and any additional rows.

**[00292]** In accordance with exemplary and non-limiting embodiments, the range of wireless energy transfer and the stack height of packaged products may be improved with a repeater resonator that is integrated or attached to each package. A repeater resonator may be added to the package to improve the coupling to the source resonator. An example of a package with a repeater resonator is depicted in Fig. 45. The package **4534** includes a device resonator **4538** that provides energy to any electronics or circuits in the packaging and a repeater resonator **4536** that may be larger than the device resonator and attached or integrated on the same or different side or face of the package than the device resonator. In this configuration multiple packages may be stacked front to back with a source resonator in the back of the packages.

**[00293]** In accordance with exemplary and non-limiting embodiments, it may be desirable to turn off or prevent energizing packages that may be in the middle of a stack or to the back of a stack. For example, illuminating a package designed to attract the attention of a consumer may only be useful when the package is visible to the consumer. Packages that are in the back of a stack may not be visible and energizing the packages may waste energy, reduce the reliability of the circuits and potentially lead to device failures. In embodiments the packages may be configured to energize or turn on only when they are in front of a display or when they are visible to a consumer.

**[00294]** In accordance with exemplary and non-limiting embodiments, packages may have sensors, such as light sensors, RFID sensors and the like that may be used to determine and activate the appropriate packaging.

**[00295]** In accordance with exemplary and non-limiting embodiments, the packaging may be configured to selectively detune device resonators that are not in front of a display. A resonator detuned from the resonant frequency of the source resonator may not efficiently receive energy from the source and may be in effect be disabled. Selective detuning of resonators may be accomplished by introducing a lossy material to mating faces of packages when stacked together. A material such as a sheet of an electrical conductor may sufficiently detune a device resonator when brought in close proximity to the device resonator. In

embodiments packaging may be designed with a small area of a lossy material positioned such that the lossy material may detune the device resonator that is not in the front of package stack.

[00296] For example, consider again the packaging **4534** depicted in Fig. 45 comprising a device resonator **4538** and a repeater resonator **4536**. The packaging may be designed to have a patch or sheet of a lossy material **4540** on the opposite side of the device resonator such that when two packages are stacked together the lossy material may load and detune the device resonator of the package in the back while not affecting the repeater resonator of each package allowing energy to pass through the repeater resonators to the front package.

[00297] A configuration with two packages is shown in Fig. 46. The configuration comprises a source resonator **4646** and two packages **4643** and **4652** each with its own repeater resonator **4650**, **4644** and device resonators **4654**, **4648** respectively. Each package may also have a patch of a lossy material **4656**, **4658**. The lossy material is positioned such that it affects the device resonator of the box in back of it. For example, the patch **4658** is positioned to detune the device resonator **4648** or the box in the back without affecting the larger repeater resonators **4644**, **4650**, nor the device resonator of the front package **15854**. Wireless energy may therefore pass from the source resonator **4646** to the device resonator of the front box **4654** via the repeater resonator of the back box **4644** without significantly energizing the device resonator **4648** of the back box.

[00298] In embodiments, efficient energy transfer may be realized when the Q of the source and/or repeater resonators is relatively high and the Q of the device resonators incorporated into the packaging are relatively low. Such lower Q resonators may comprise inductive elements comprising printed conductors, conducting inks, paints and the like. Inductive elements that are easy to manufacture and safe to dispose of may be preferable in packaging applications, even if the loss of these elements is higher than electronics grade copper, as an example. Higher loss conductors comprising carbon traces and/or lower conductivity but printable conductors may be suitable for this application because efficient power transfer may be realized using either or both higher Q source and repeater resonators.

[00299] In embodiments, whole new marking and communication capabilities may be realizable using this inventive wireless power transfer scheme. For example, by enabling wireless power transfer to product packaging, the packaging itself may include new functionality. For example, the packaging may include communications functionality that

allows the displayed price to be updated via a wireless communication link. In a retail environment, a package may communicate with the cell phone of a consumer passing by, and cause the phone to ring or vibrate or emit an audible tone to alert the consumer to the fact that the product is on special, or has been improved, or has been reviewed, etc. In a warehouse environment, a package may communicate with a centralized database so that its location can be easily identified. For example, the UPS driver may not need to scan his packages anymore because the packages will be able to communicate wirelessly with tracking software in the warehouse, in the truck, and may be further integrated with a GPS tracking scheme so that rather than just saying "on truck", a package could be tracked to the street location of the truck at a given time. Maybe the truck route could be displayed along with a more accurate estimated arrival time.

**[00300]** Wireless communication functionality might also be used to form ad hoc networks of multiple packages and the display capabilities or light-up capabilities enabled by wireless power transfer may be further enhanced by creating synchronized displays involving multiple packages. For examples, the light-up functionality might be synchronized to create a flashing light display, or a display where the lights "run around the packaging". In addition to lights, wireless power may be used to power audible tones or to deliver marketing apps over a wireless link.

**[00301]** Wireless communication could be coupled with an "in-carriage" system that displays the cost of the contents of the carriage to the consumer. The carriage could have wireless power capability to supply power to packages in the cart. The carriage could be powered by rechargeable batteries that are wirelessly recharged as the carriages sit at the carriage stands or the carriages could be powered from source coils in the floor as the carriages are pushed around a store. For fast selling items like the tickle me elmo or iphone, a consumer could download an app on their phone that allows them to instantaneously get a count of how many products are available at any given store.

**[00302]** Wireless power apps could include maps of power sources, power management and sharing, billing if you let someone have some of your power (their credit card could pay you before you share your power, or you could choose to exchange it for free) it might happen without you even knowing it. You could set your phone so that you always share power with a paying customer as long as you are at least 50% charged. You could also set your phone to be pinging for available power at a certain price any time your charge state gets below a certain level. You could set it to pay more for power when you reach a certain

critical power level. Apps might be coordinated with sales, coupons, etc information that is wirelessly transmitted by wirelessly powered devices. Apps might link certain products with recipes or consumer reviews or allow a user to comment or input data that could be made available for other app users. Warnings could be displayed like spinach is currently suspected to be the cause of an e-coli outbreak. Foods or products that need to be recalled might be able to identify themselves on a shelf so that they can be identified and removed by store employees or avoided by consumers.

**[00303]** While the invention has been described in connection with certain preferred embodiments, other embodiments will be understood by one of ordinary skill in the art and are intended to fall within the scope of this disclosure, which is to be interpreted in the broadest sense allowable by law.

**[00304]** All documents referenced herein are hereby incorporated by reference in their entirety as if fully set forth herein.

## CLAIMS

What is claimed is:

1. A method of energizing a wireless energy source from a photovoltaic module, the method comprising: using electric energy from a photovoltaic module to energize at least one wireless energy source to produce an oscillating magnetic field, and configuring said source to present an impedance to a photovoltaic module, wherein said impedance enables extraction of energy from said photovoltaic module.
2. The method of claim 1 further comprising the step of transforming the oscillating magnetic field to electrical energy using a wireless energy capture device positioned distal from and not electrically wired to the wireless energy transfer source.
3. The method of claim 1 further comprising adjusting the impedance of said source in response to a change in the environmental conditions for the photovoltaic module.
4. The method of claim 2, further comprising configuring the impedance of said source in response to a change in electrical parameters of the photovoltaic module.
5. The method of claim 4 further comprising decreasing the impedance of said source in response to an increase in current from said photovoltaic module.
6. The method of claim 4 further comprising increasing the impedance of said source in response to a decrease in current from said photovoltaic module.
7. The method of claim 4 further comprising decreasing the impedance of said source in response to an increase in voltage from the photovoltaic panel.
8. The method of claim 4 further comprising increasing the impedance of said source in response to a decrease in voltage from the photovoltaic panel.



9. The method of claim 4, wherein configuring said impedance further comprises adjusting a switching time of the wireless energy source.

10. The method of claim 4, wherein configuring said source further comprises adjusting two or more of an inductance, capacitance, resistance, or switching time of the wireless energy transfer source.

11. The method of claim 4, wherein configuring said source further comprises adjusting one or more inductance, capacitance, resistance, or switching time of the wireless energy capture device.

12. A photovoltaic energy system with wireless energy transfer, the system comprising: a photovoltaic module generating an electrical energy, a wireless energy source, connected to the photovoltaic module and powered by said electrical energy, generating an oscillating magnetic field, wherein the impedance of the wireless energy source is configured to present a specific impedance to the photovoltaic module.

13. The system of claim 12, further comprising a wireless energy device, wherein the wireless energy device is configured to capture the oscillating magnetic field and convert the energy of the magnetic field to an electrical current at a voltage.

14. The system of claim 13 wherein the wireless energy device is adjustable to achieve a particular current at the output of the device.

15. The system of claim 13 wherein the wireless energy device is adjustable to achieve a particular voltage at the output of the device.

16. The system of claim 13, wherein impedance of said source is configurable in response to a change in electrical parameters of the photovoltaic module.

17. The system of claim 14, wherein a plurality of wireless energy capture devices having similar output currents are configured in series connection.

18. The system of claim 17, wherein the output current is adjustable to maintain an expected voltage across the series connection.

19. The system of claim 15, wherein a plurality of wireless energy capture devices having similar output currents are configured in parallel connection.

20. The system of claim 19, wherein the output voltage is adjustable to maintain an expected current from the parallel connection.

21. A method of transferring energy from a renewable energy system connected to a wireless energy source, the method comprising: configuring said source for energy transfer between resonators, wherein at least one resonator is connected to a wireless energy capture device, and further configuring said source to present an impedance to a renewable energy system, wherein said impedance enables extraction of energy from said renewable energy system.

22. The method of claim 21, further comprising adjusting the impedance in response to a change in the environmental conditions for said renewable energy system.

23. The method of claim 22, wherein the renewable energy system includes a wind turbine.

24. The method of claim 22, wherein the renewable energy system includes a water turbine.

25. The method of claim 22, wherein the renewable energy system includes a thermal exchanger.

Fig. 1

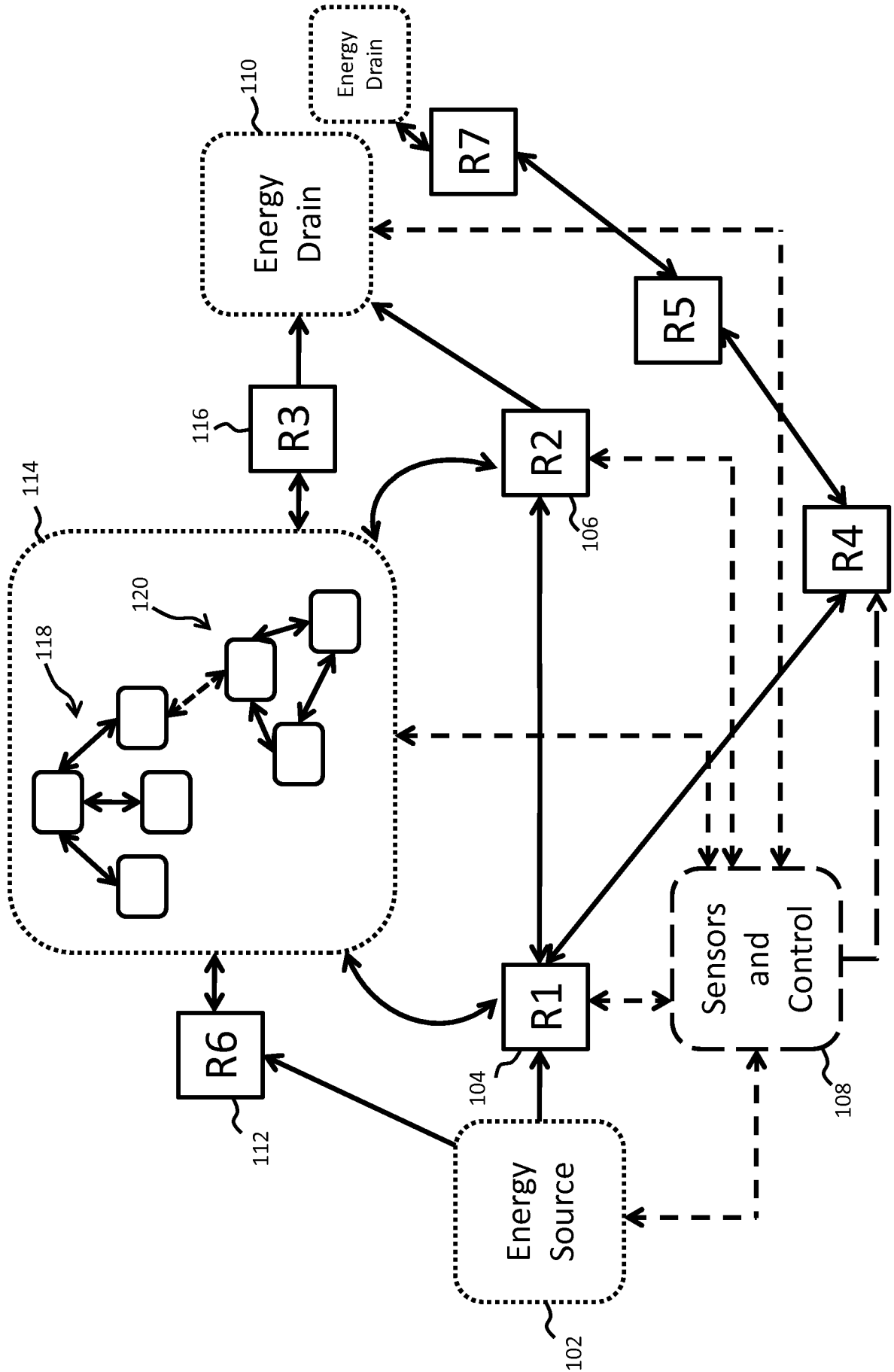

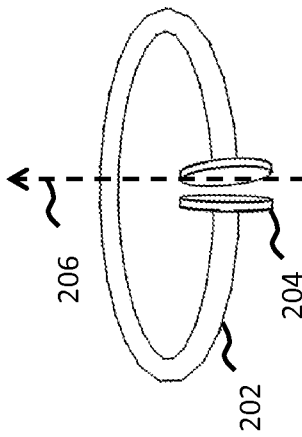

FIG. 2A

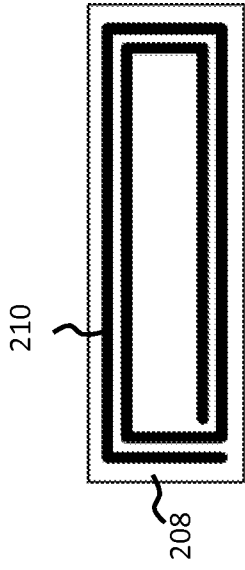

FIG. 2B

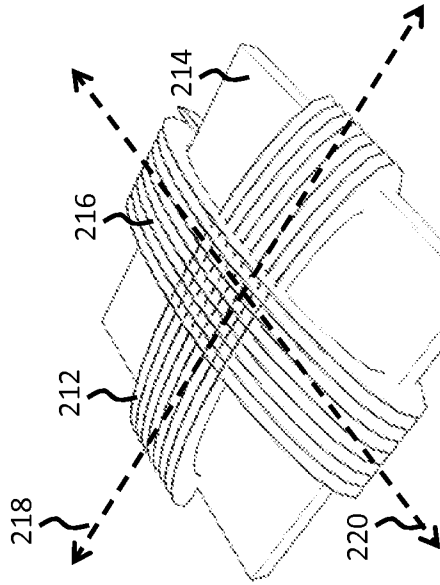

FIG. 2C

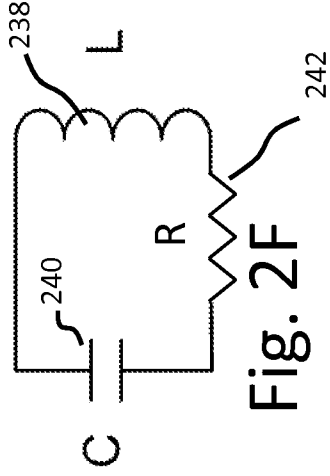

FIG. 2F

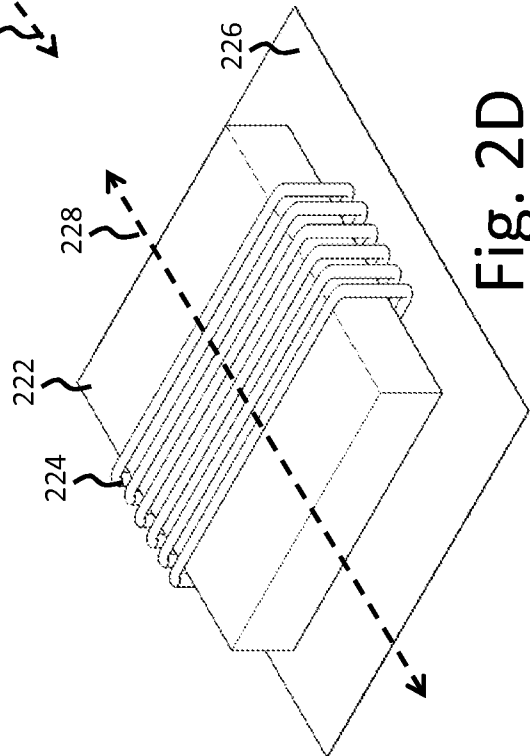

FIG. 2D

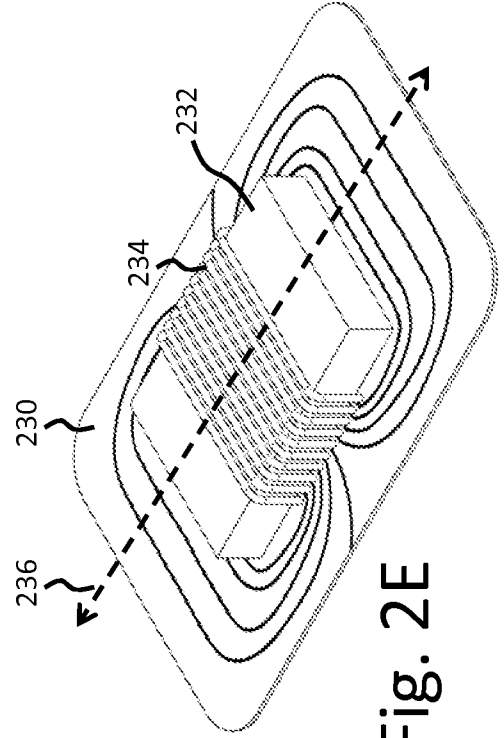

FIG. 2E

Fig. 3

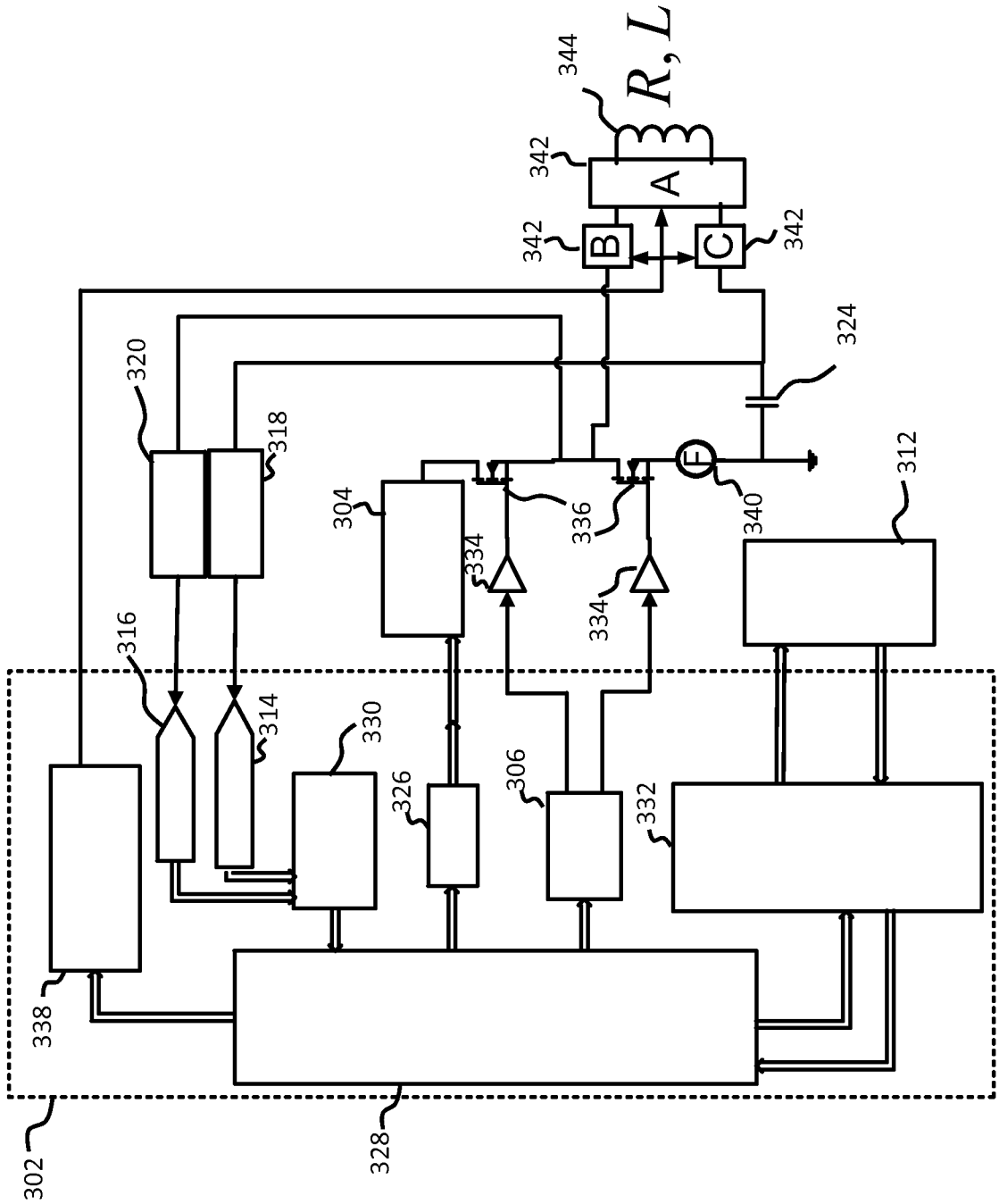
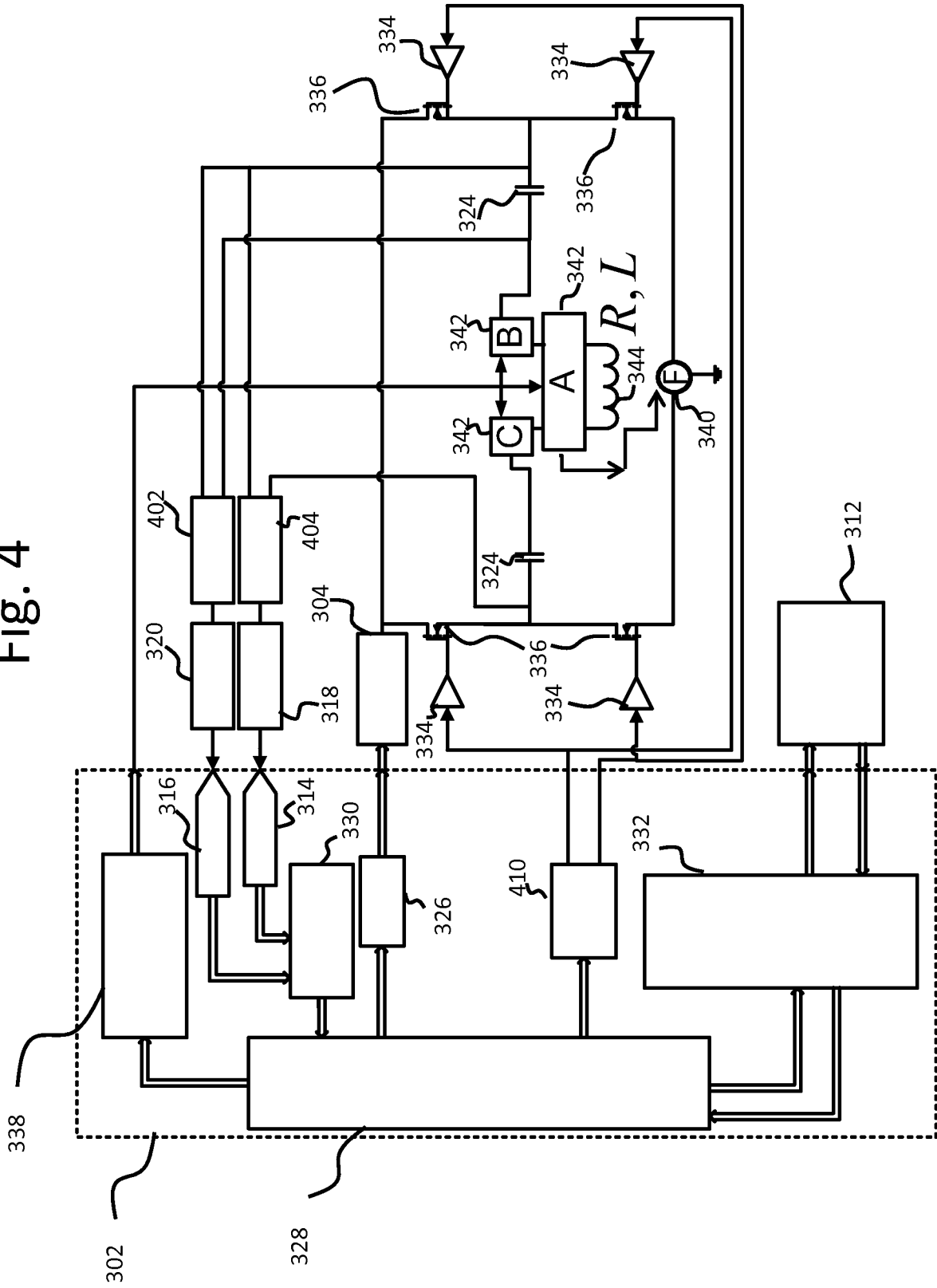

Fig. 4



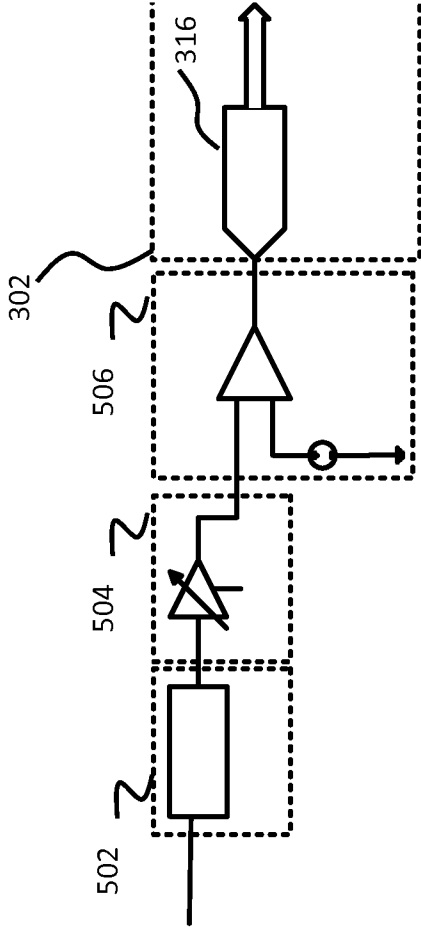

Fig. 5A

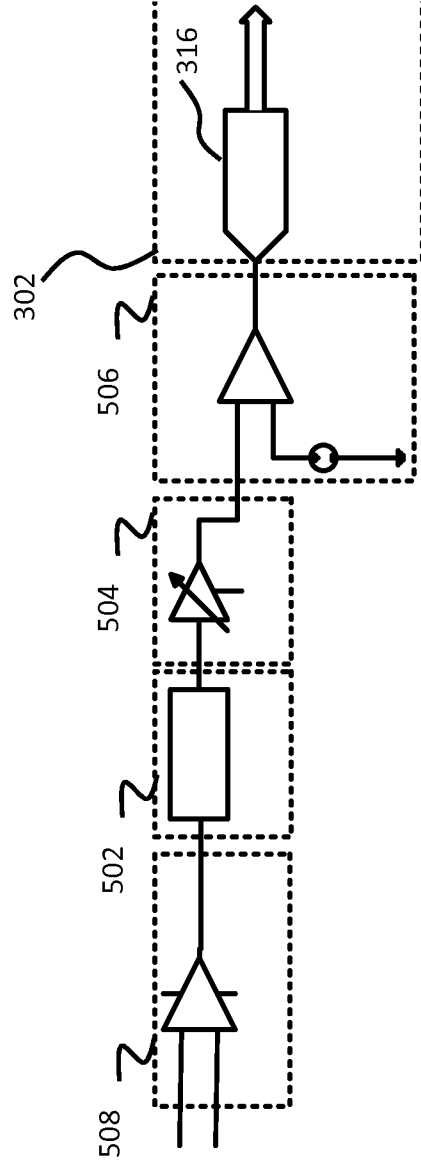

Fig. 5B

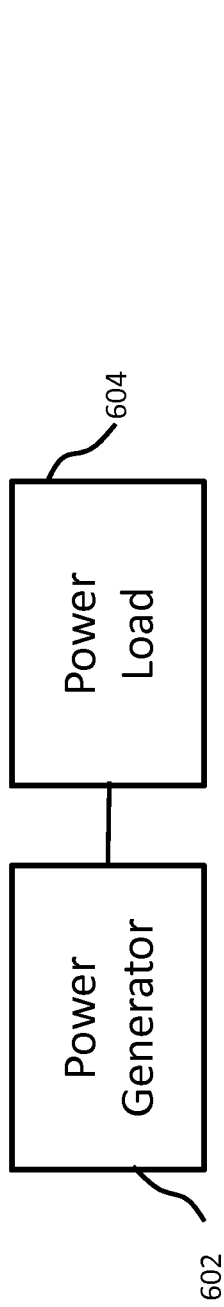

Fig. 6A

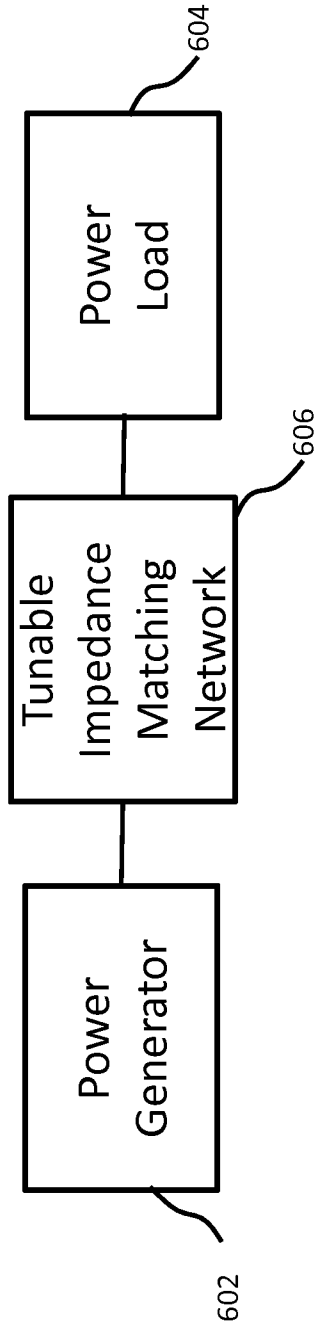

Fig. 6B

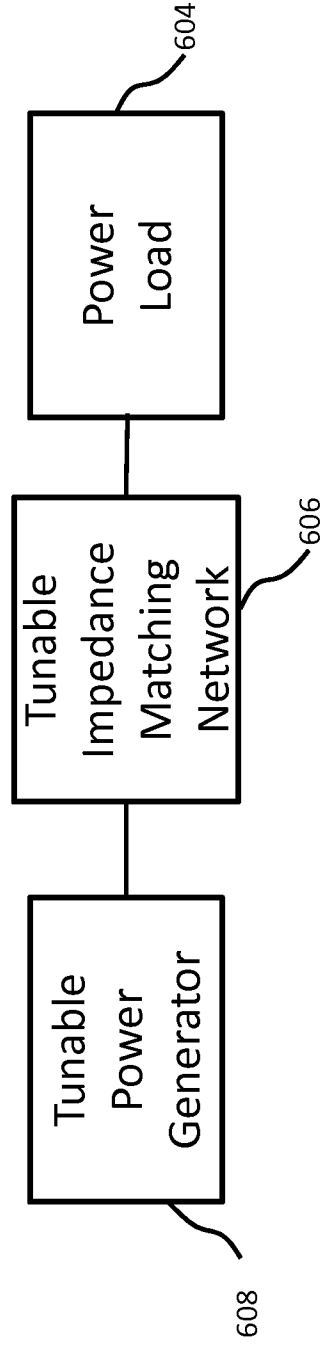

Fig. 6C



Fig. 7

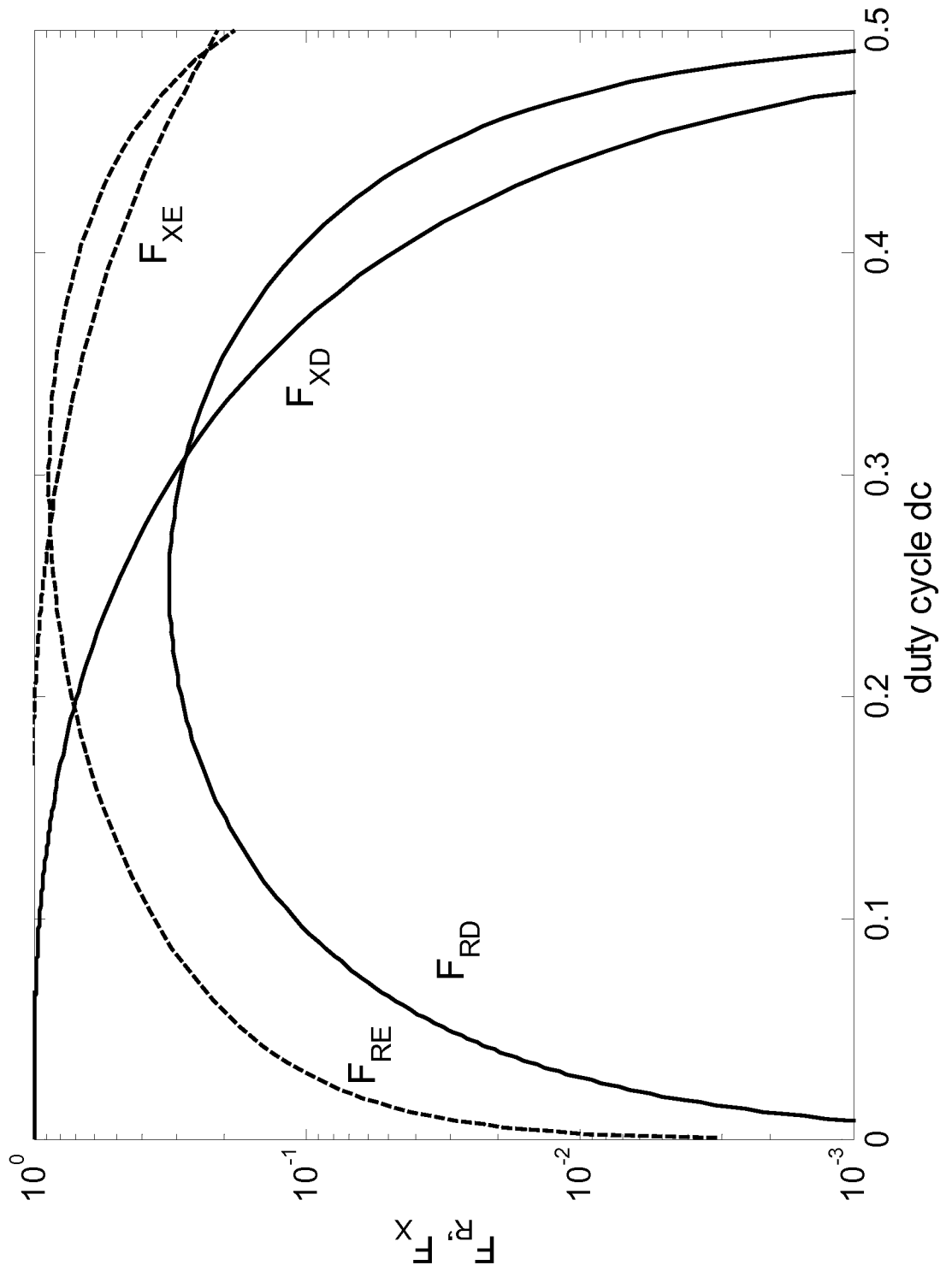

Fig. 8

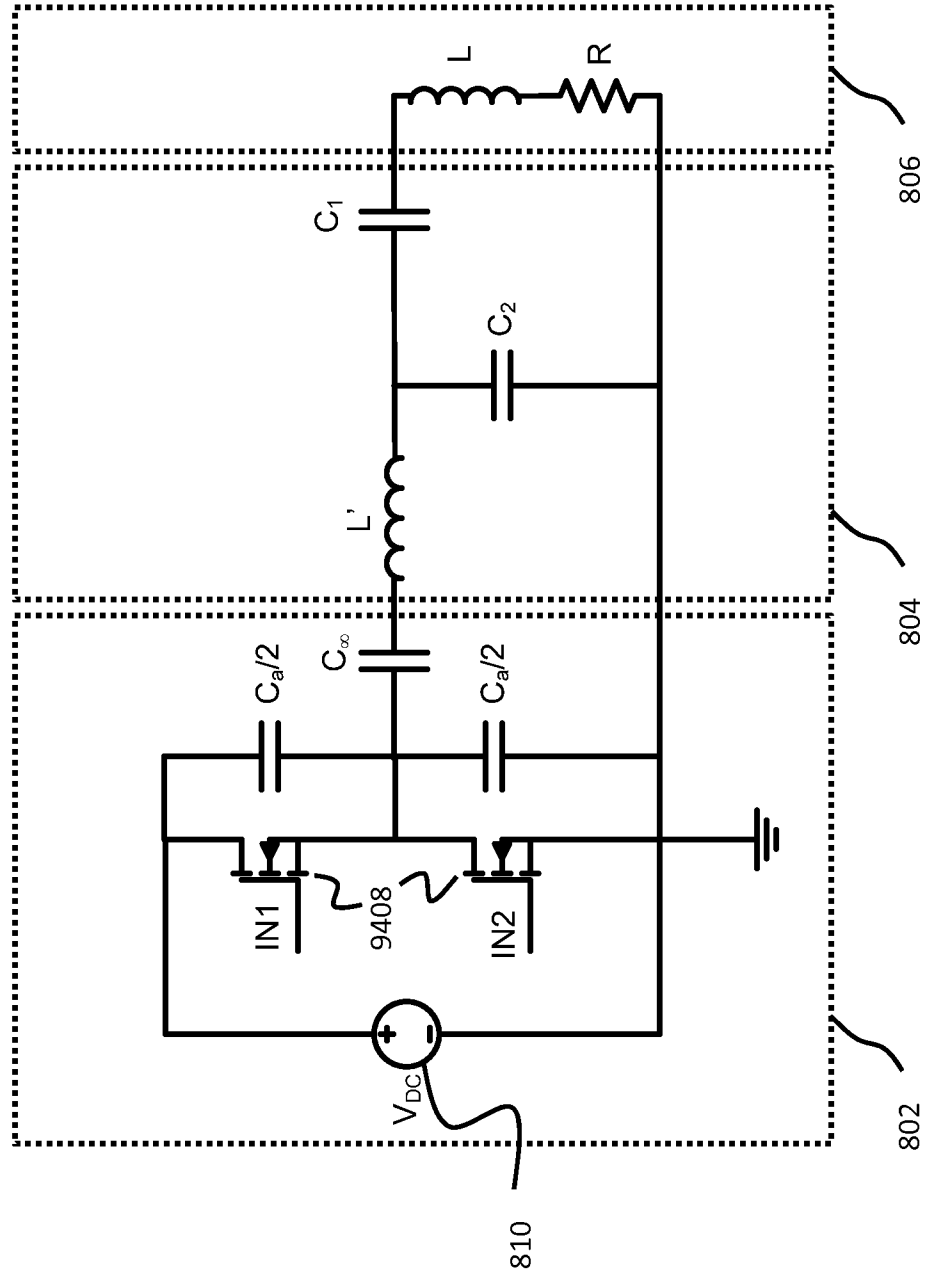

Fig. 9

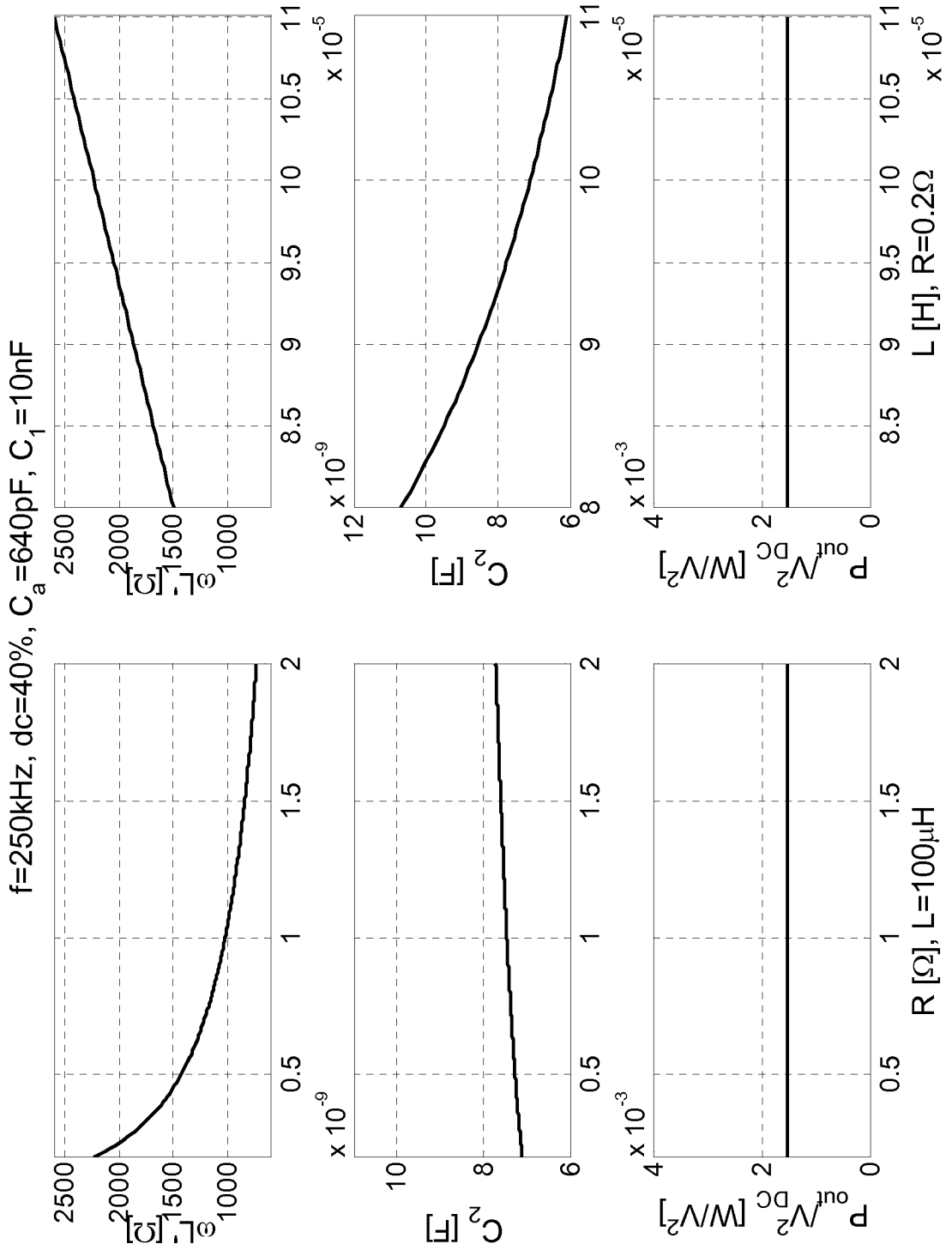

Fig. 10

$f=250\text{kHz}$ ,  $\text{dc}=40\%$ ,  $C_1=10\text{nF}$ ,  $\omega L'_g=10000\Omega$

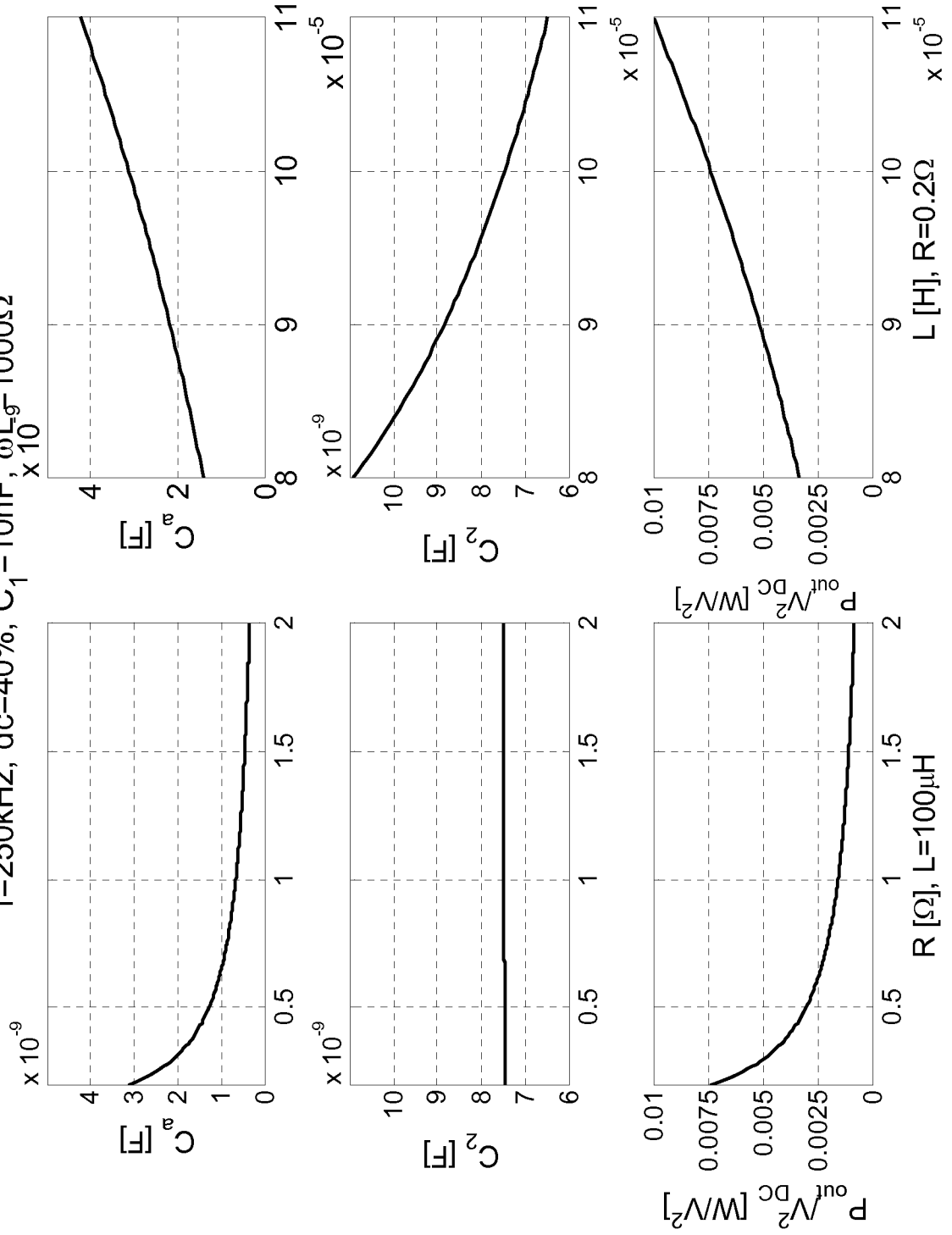

Fig. 11A

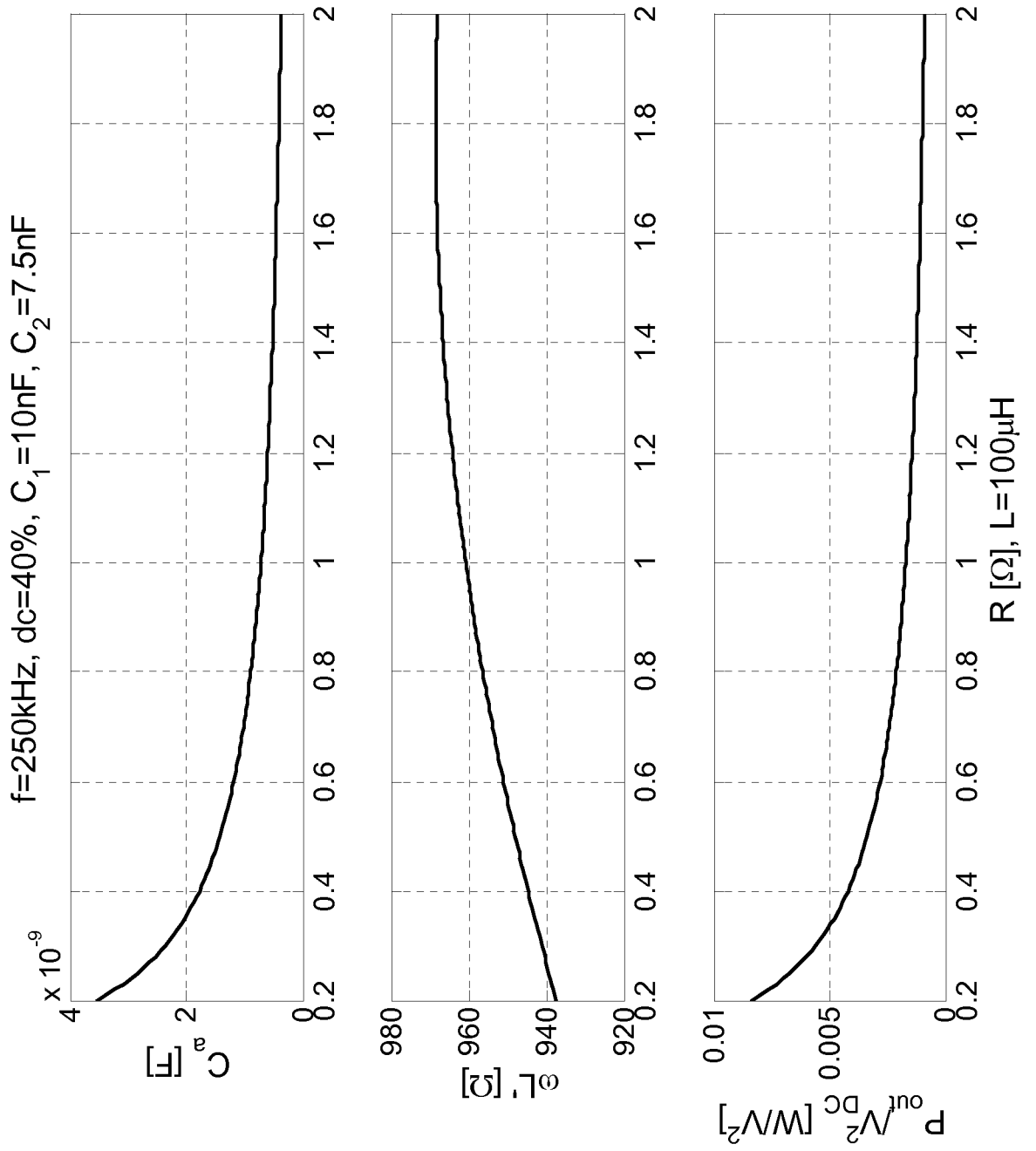

Fig. 11B

$f=250\text{kHz}$ ,  $\text{dc}=40\%$ ,  $C_1=10\text{nF}$ ,  $C_2=7.5\text{nF}$

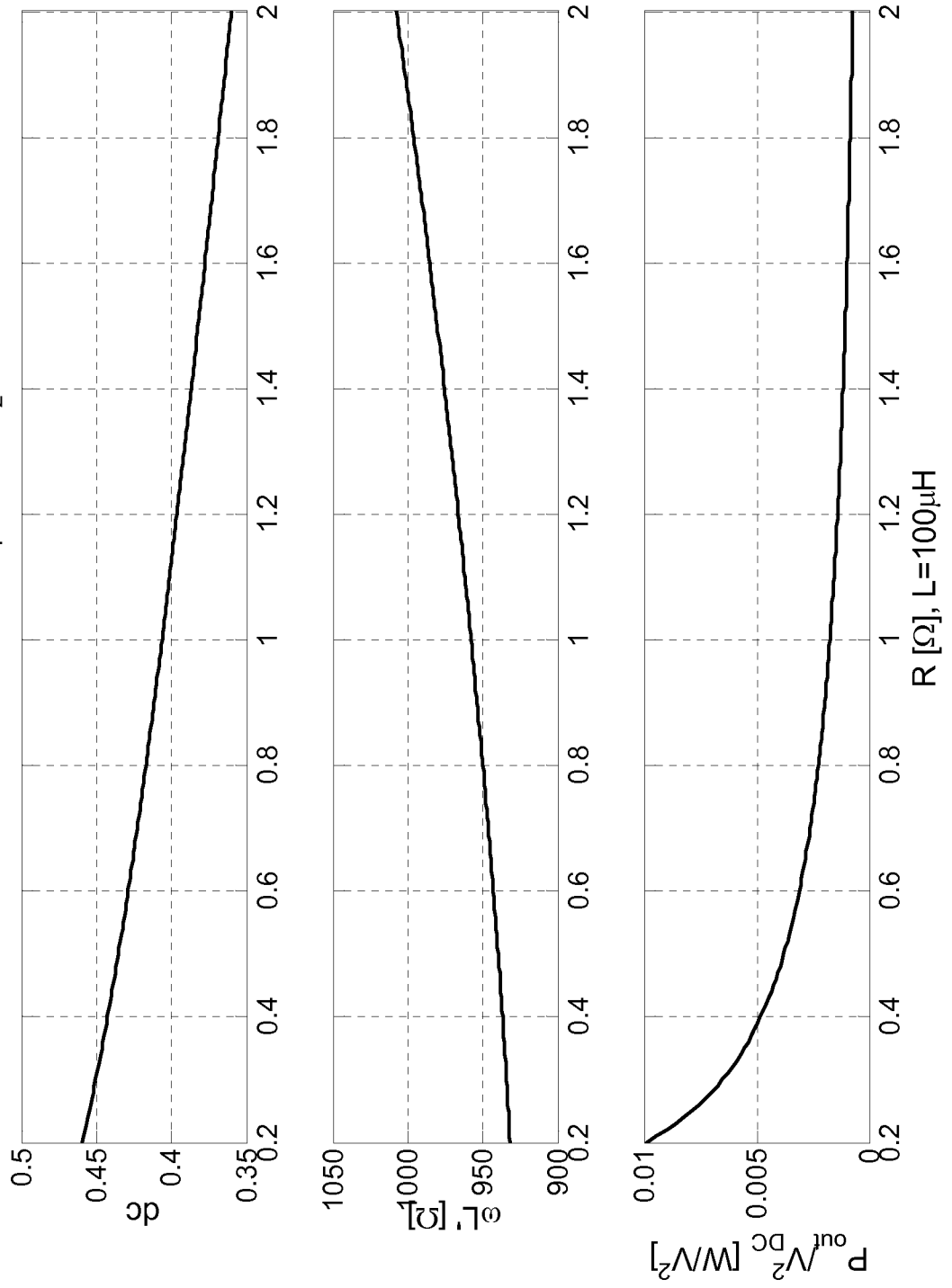

Fig. 11C

$f=250\text{kHz}$ ,  $C_1=10\text{nF}$ ,  $C_2=7.5\text{nF}$ ,  $\omega L'=1000\Omega$

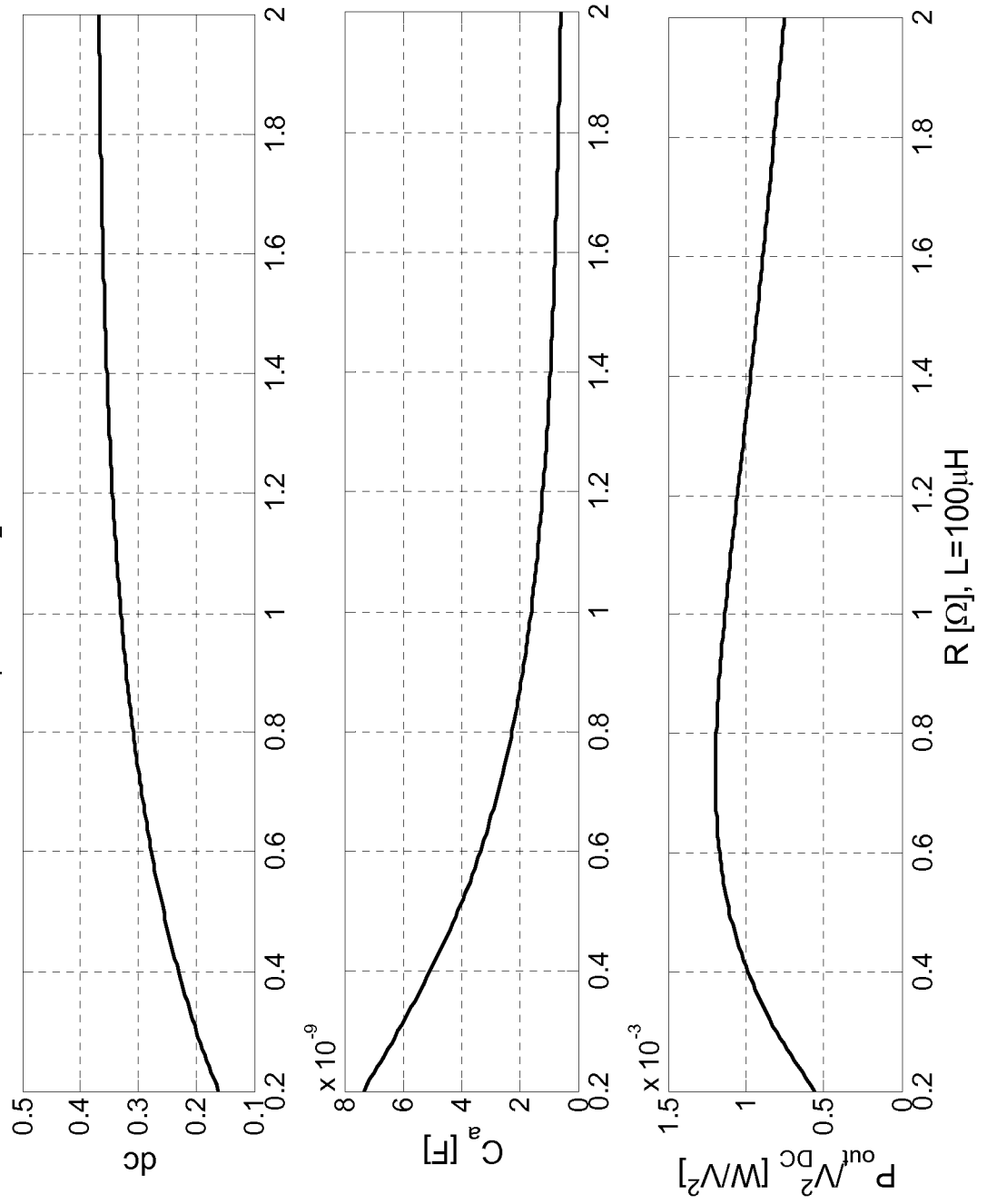

Fig. 11D

$f=250\text{kHz}$ ,  $C_g=640\text{pF}$ ,  $C_1=10\text{nF}$ ,  $\omega L=1000\Omega$

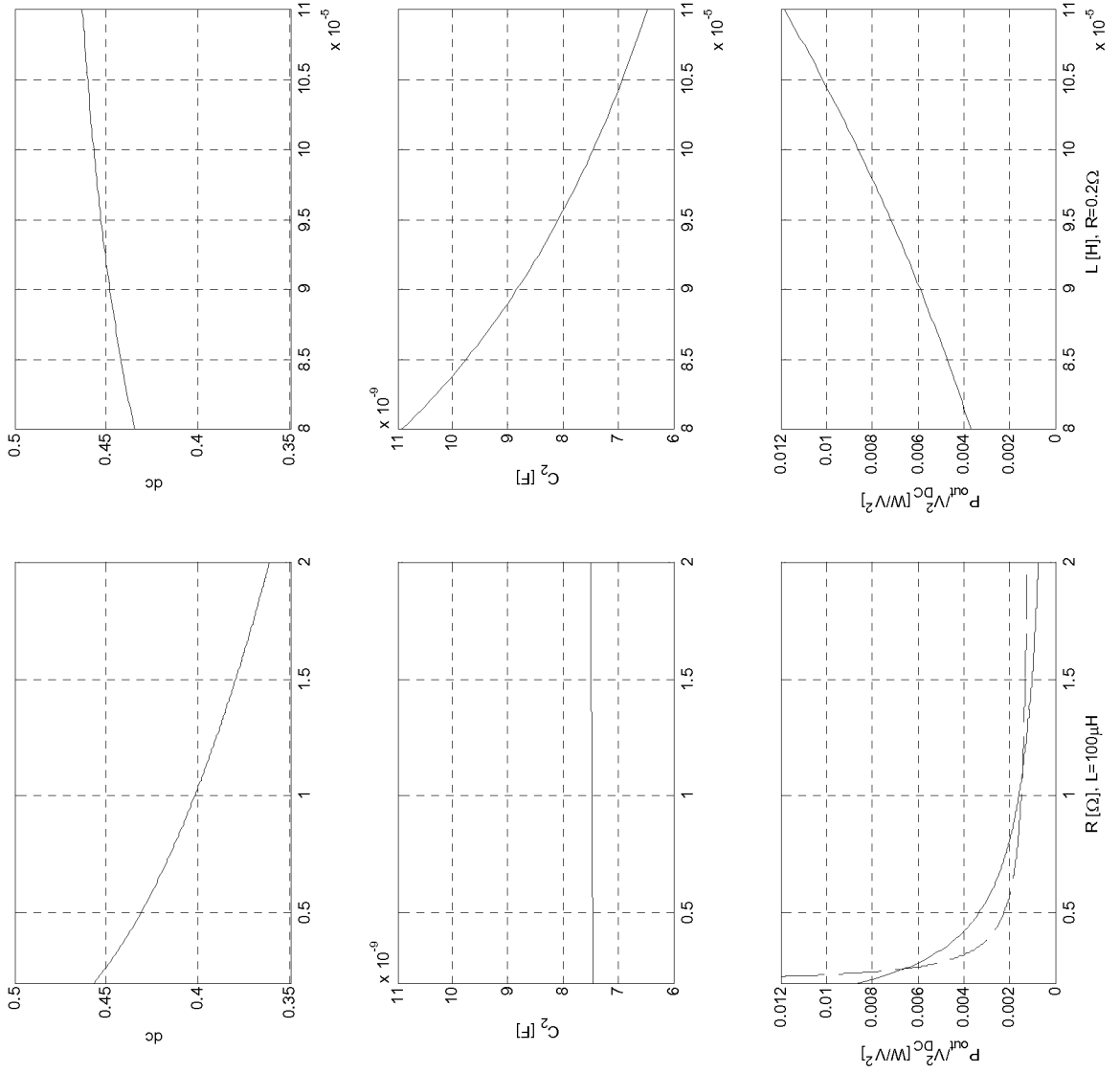



Fig. 12

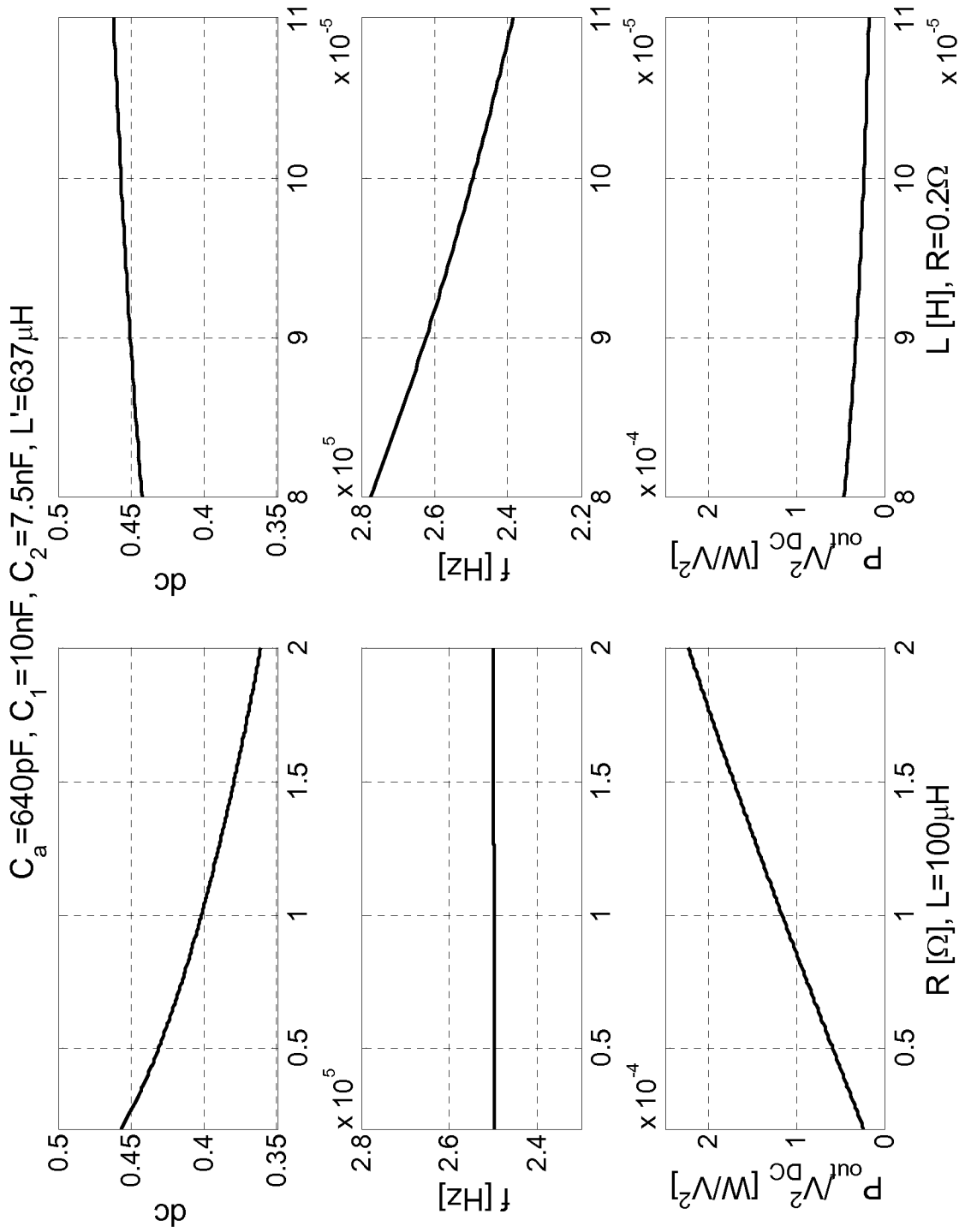

Fig. 13

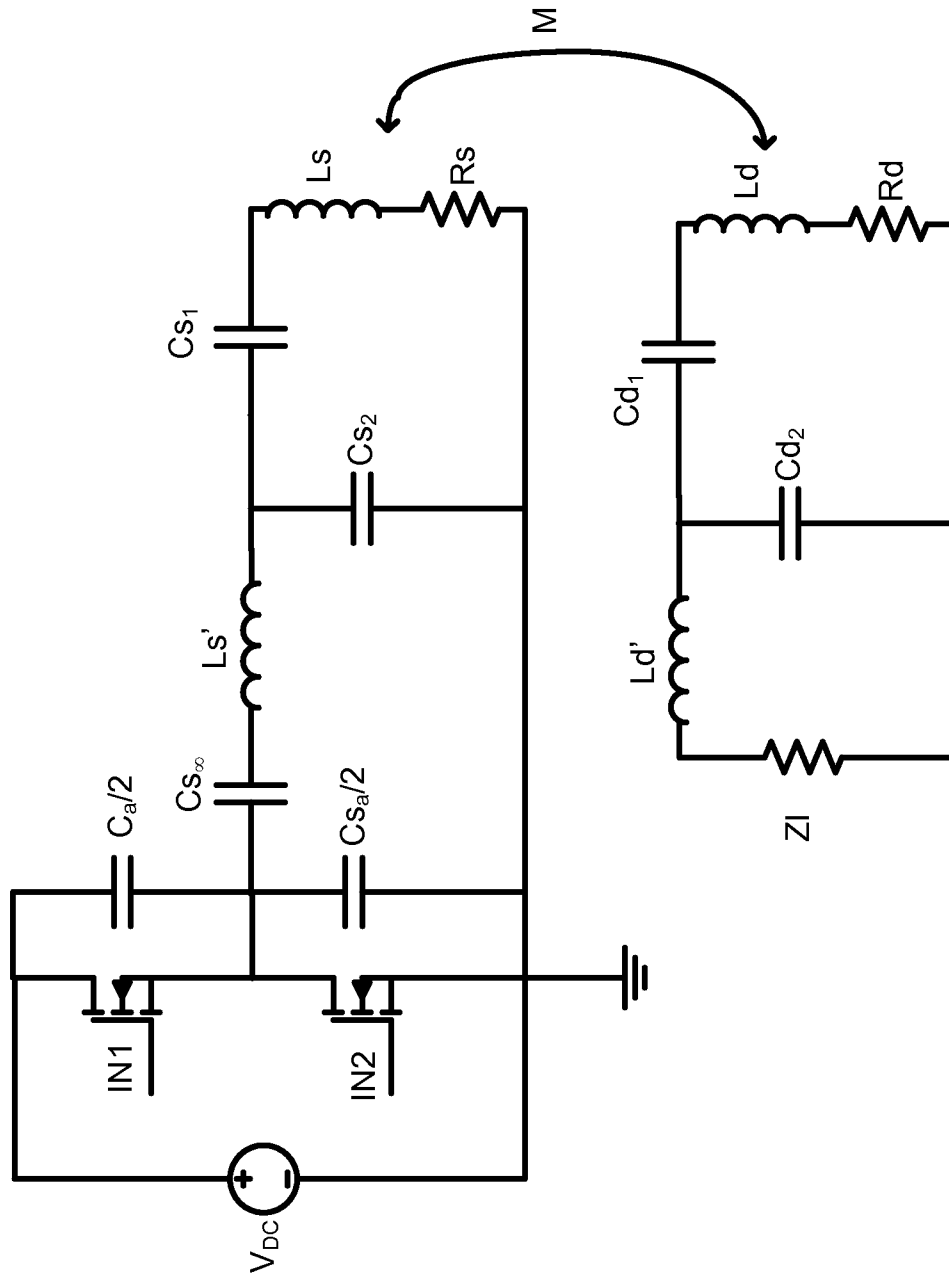

Fig. 14

$f=250\text{kHz}$ ,  $C_{as}=640\text{pF}$ ,  $R_s=0.19\Omega$ ,  $L_s=100\mu\text{H}$ ,  $C_{1s}=10\text{nF}$ ,  $\omega L'_s=10000\Omega$   
 $Z_{load}=50\Omega$ ,  $R_d=0.3\Omega$ ,  $L_d=40\mu\text{H}$ ,  $C_{1d}=87.5\text{nF}$ ,  $C_{2d}=13\text{nF}$ ,  $\omega L'_d=400\Omega$

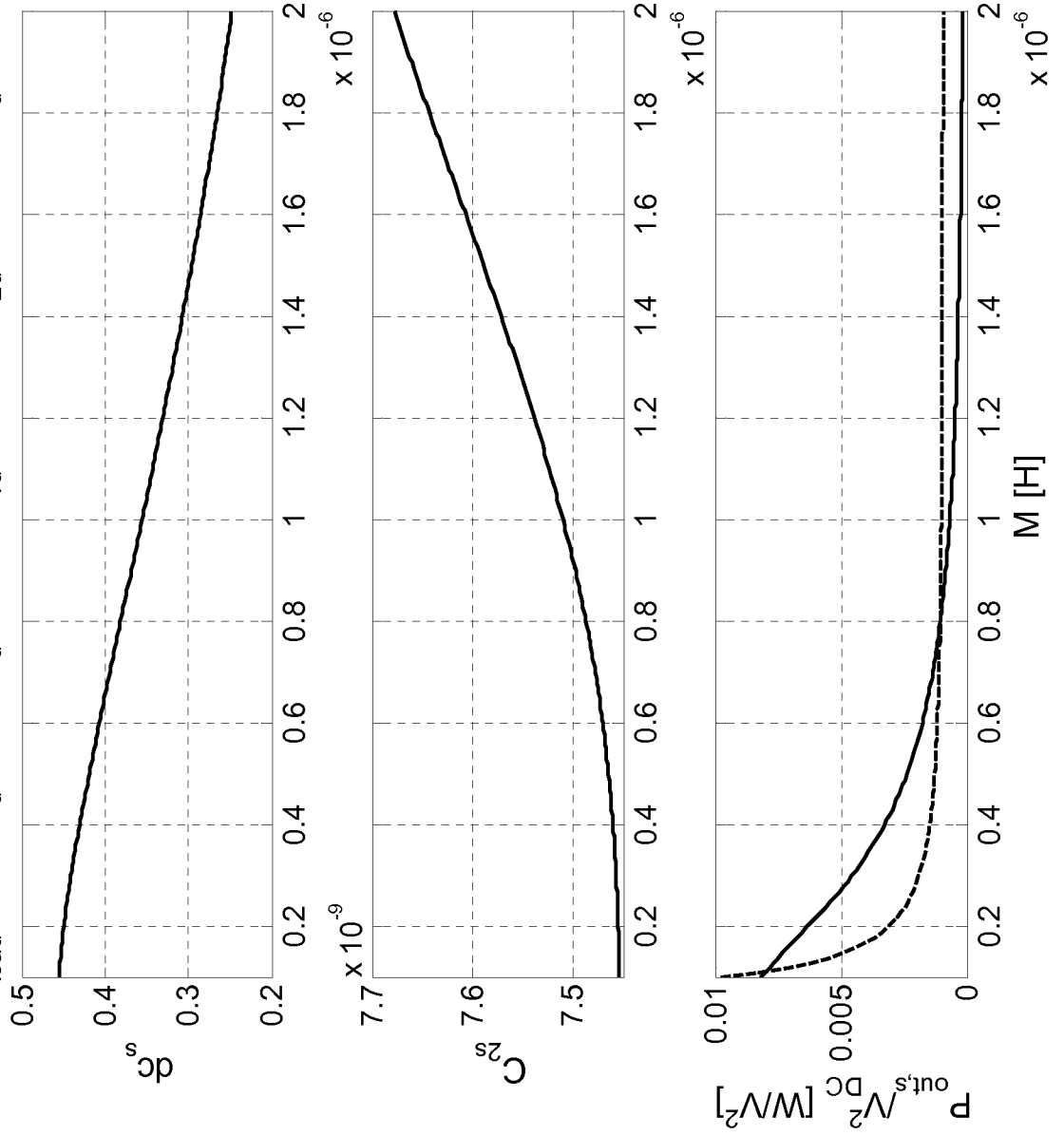

Fig. 15

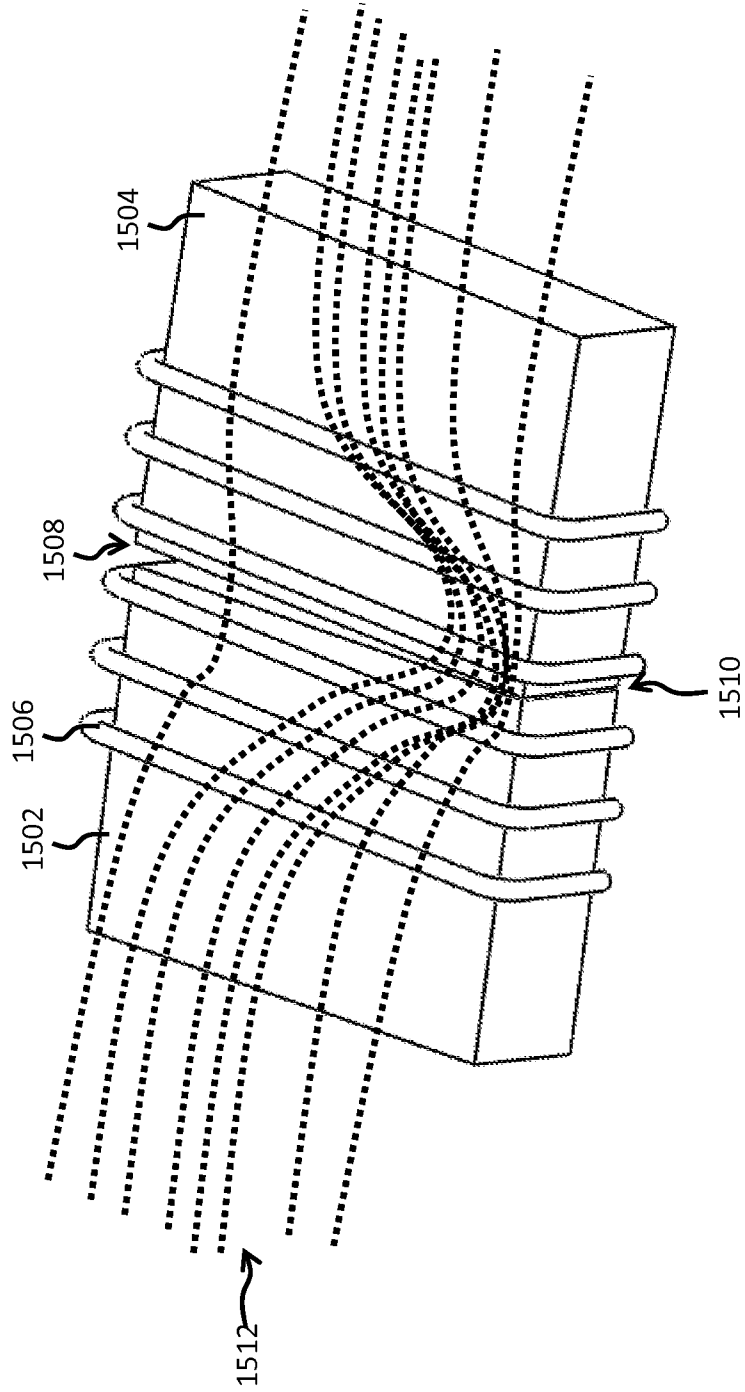
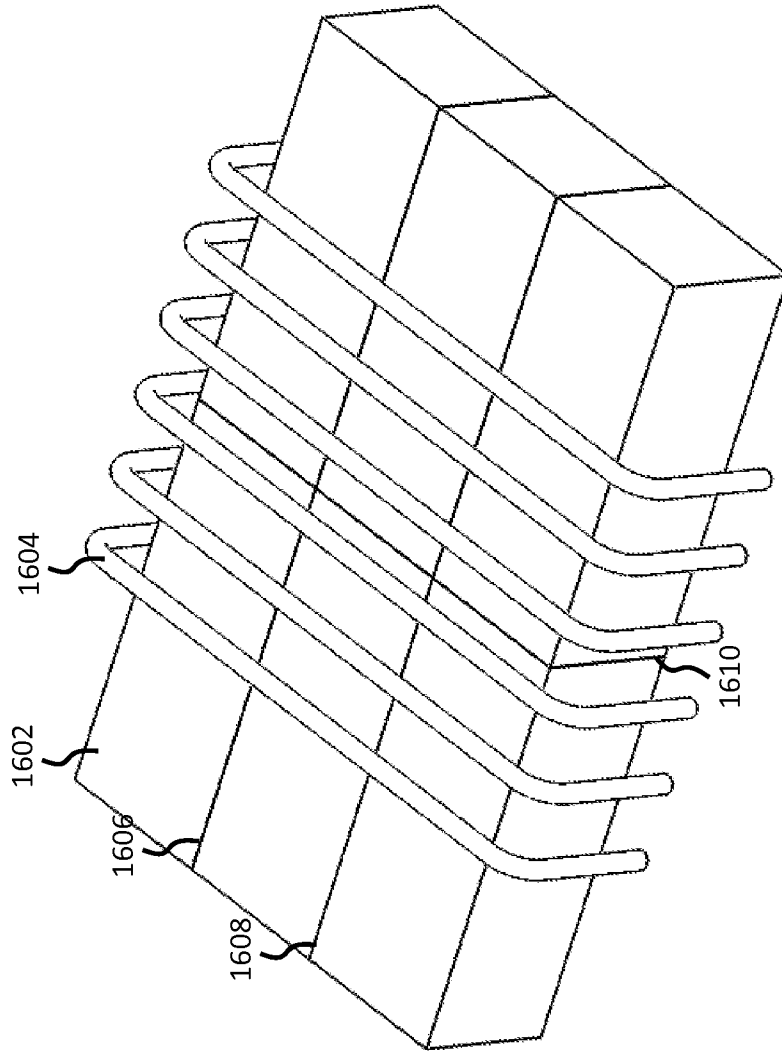

Fig. 16



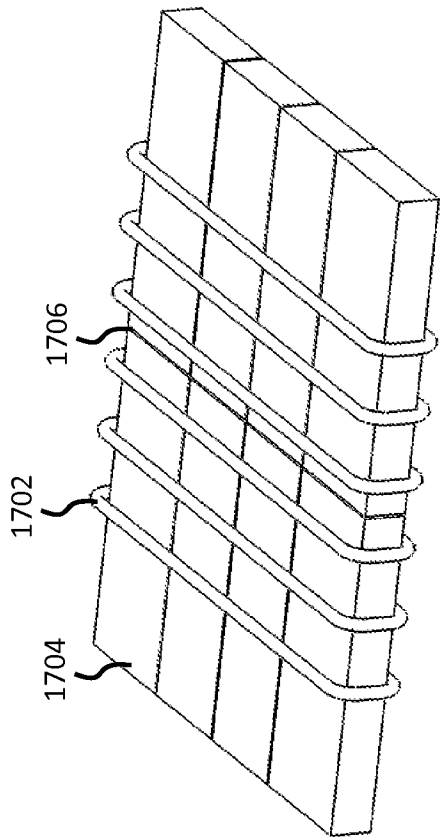

Fig. 17A

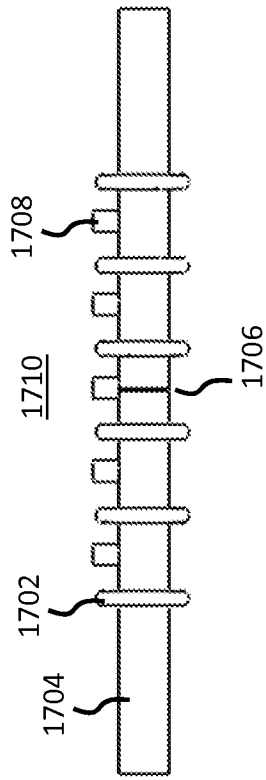

Fig. 17B

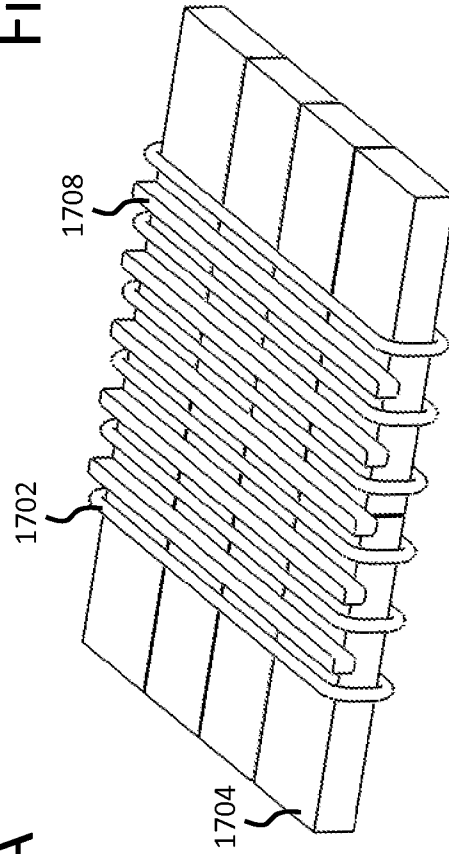

Fig. 17C

Fig. 18

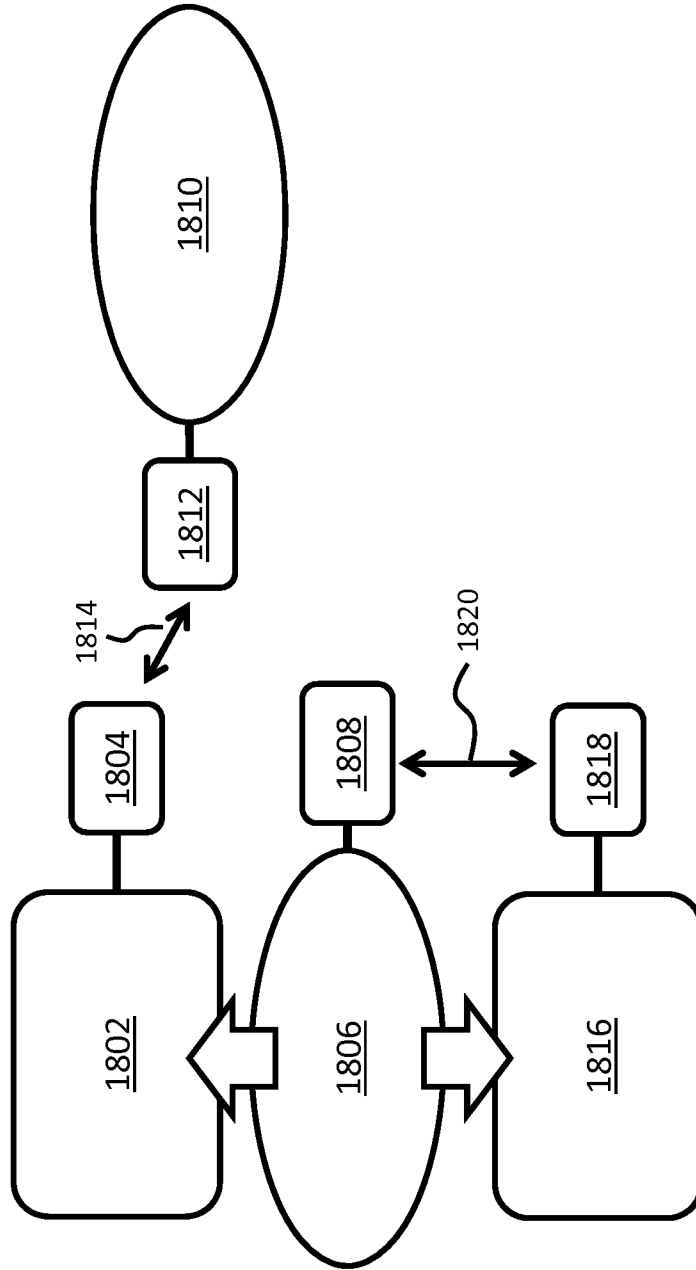

Fig. 19A

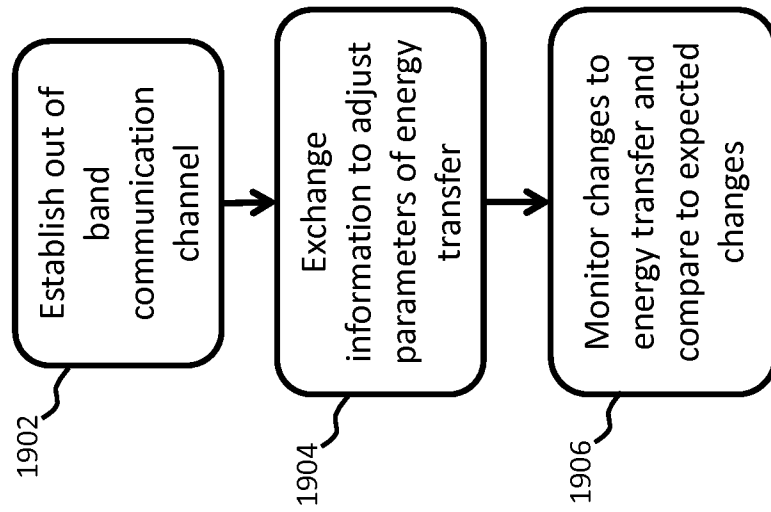

Fig. 19B

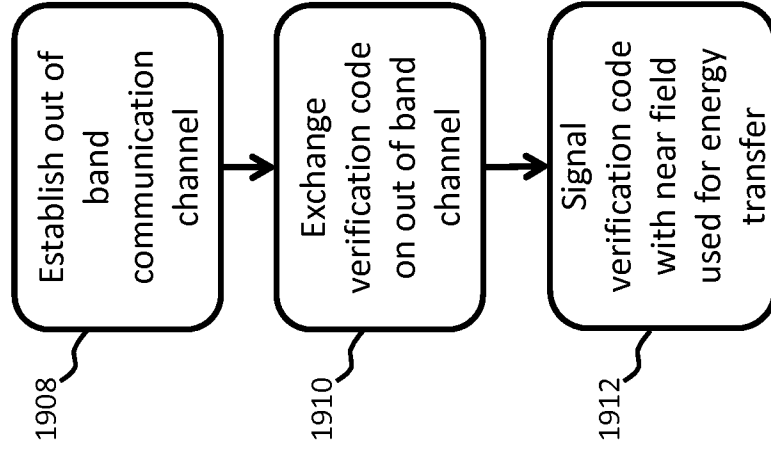



Fig. 20

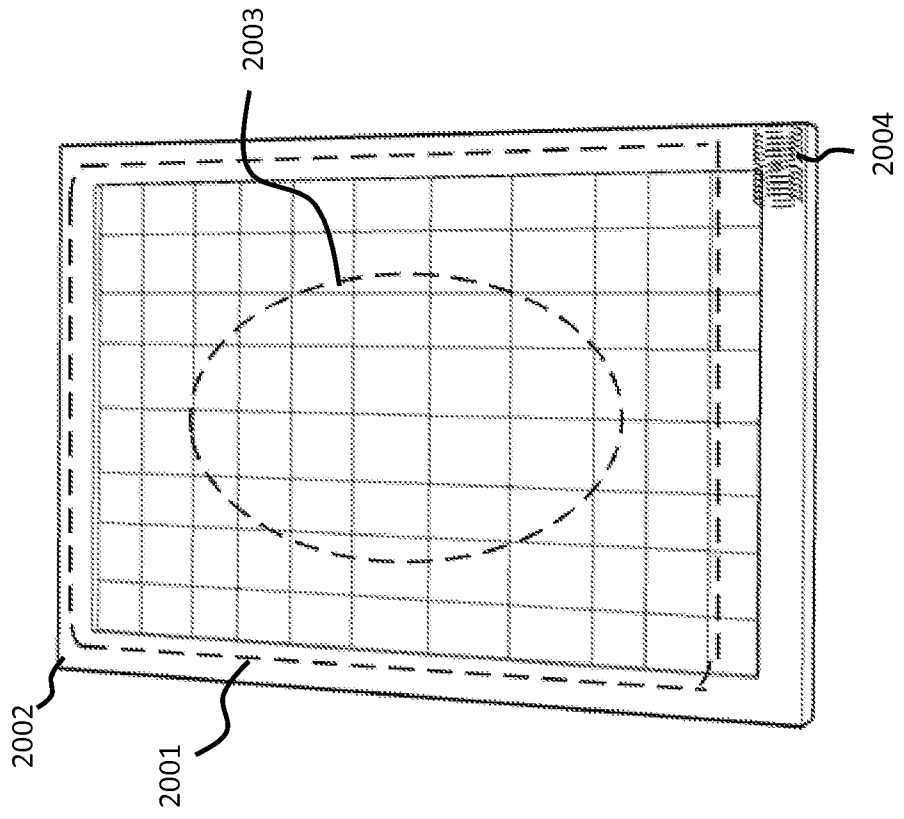

Fig. 21

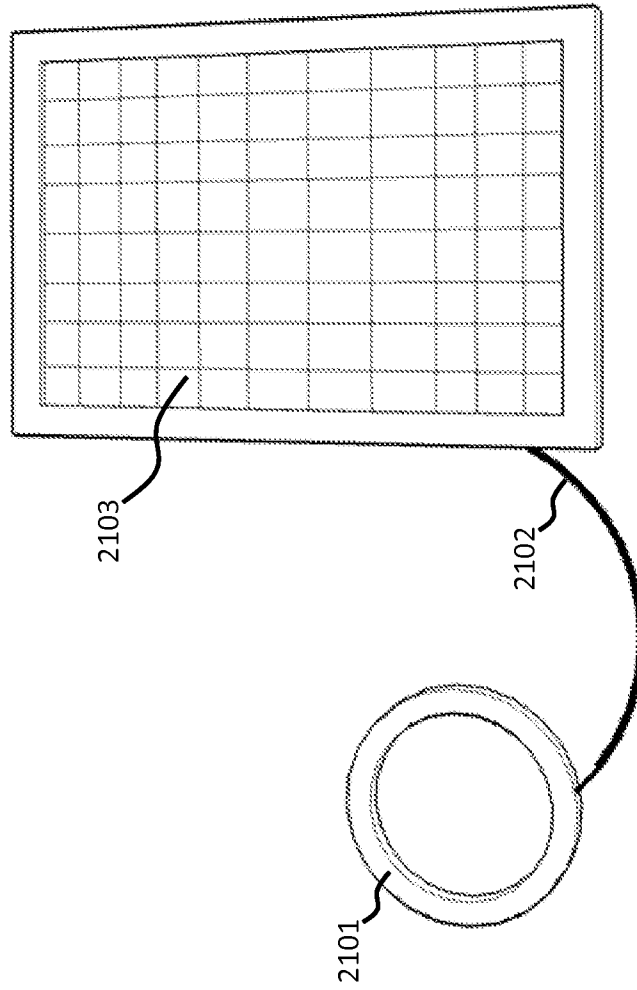

Fig. 22

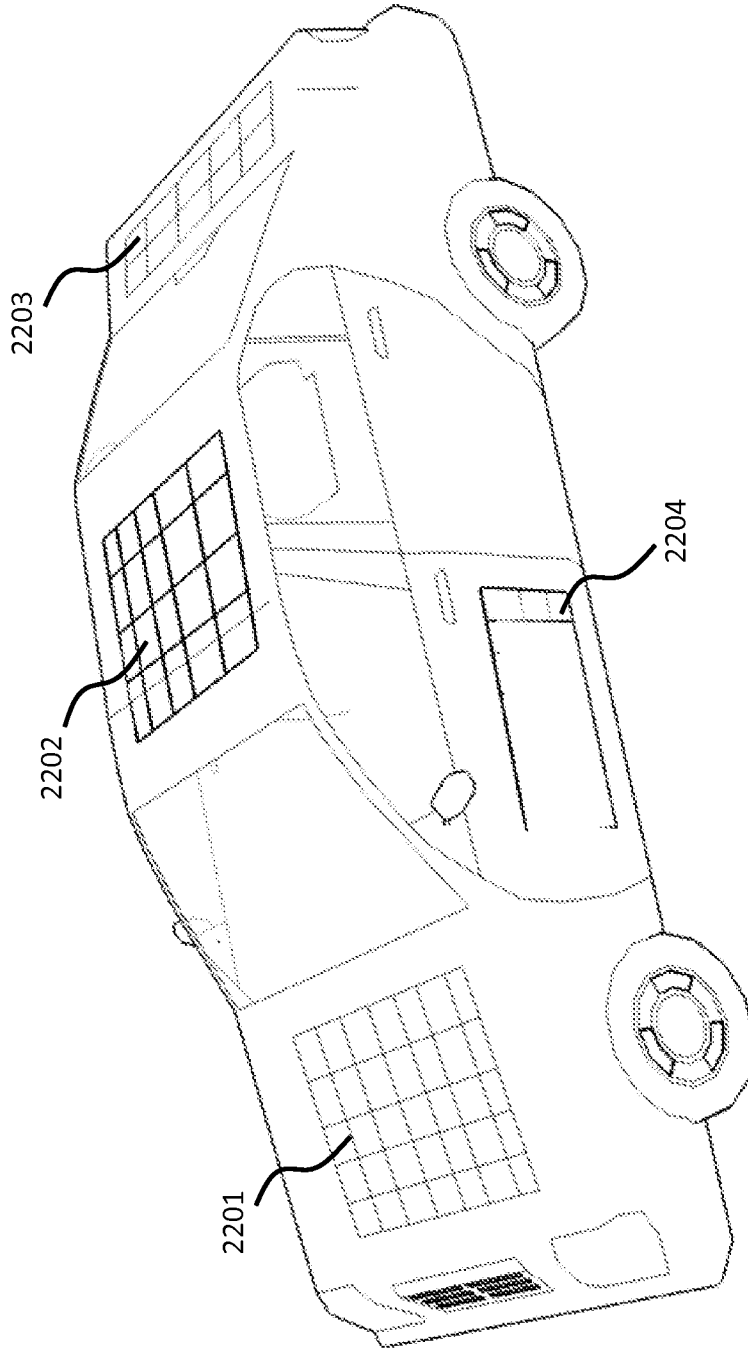

Fig. 23

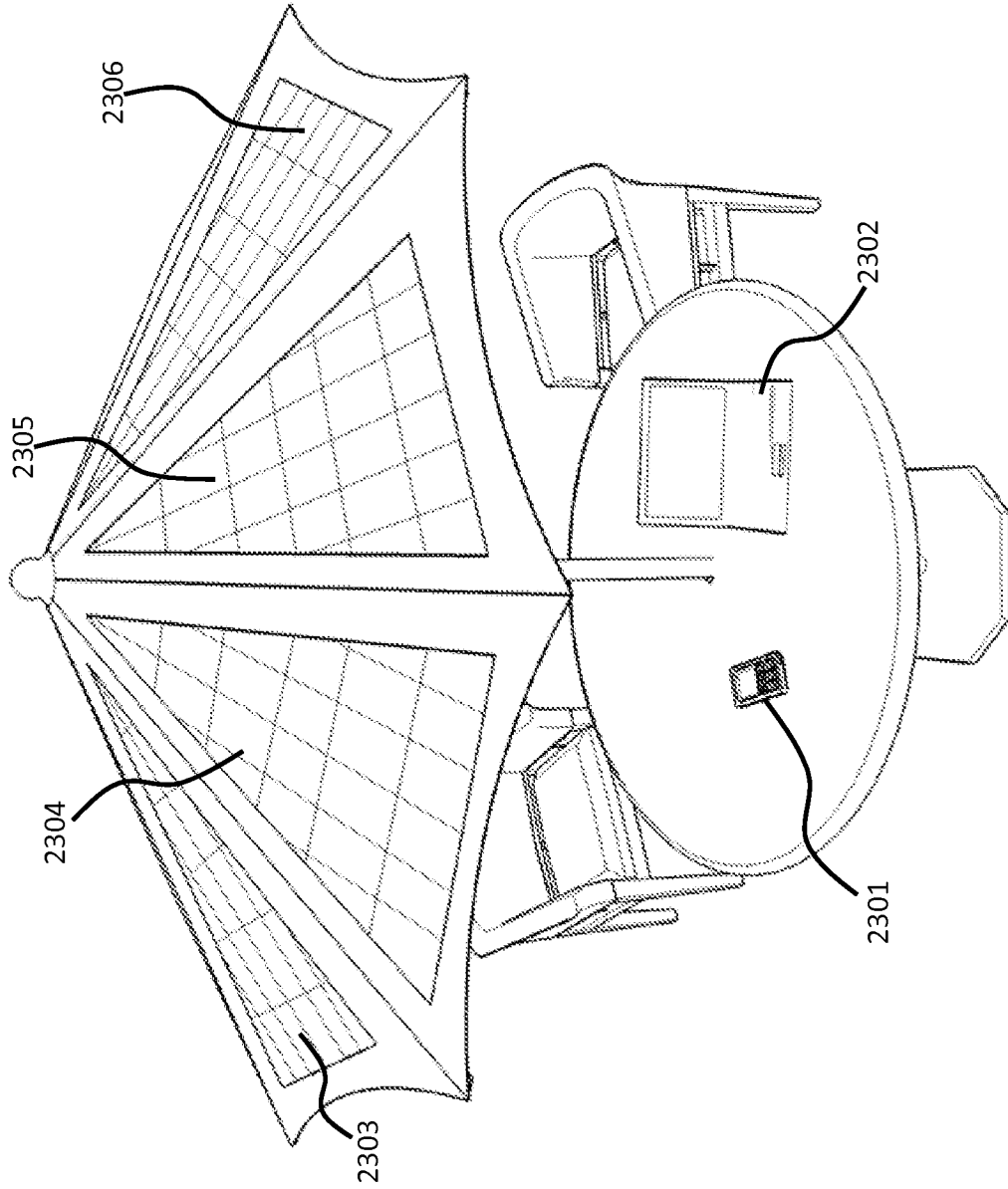

Fig. 24

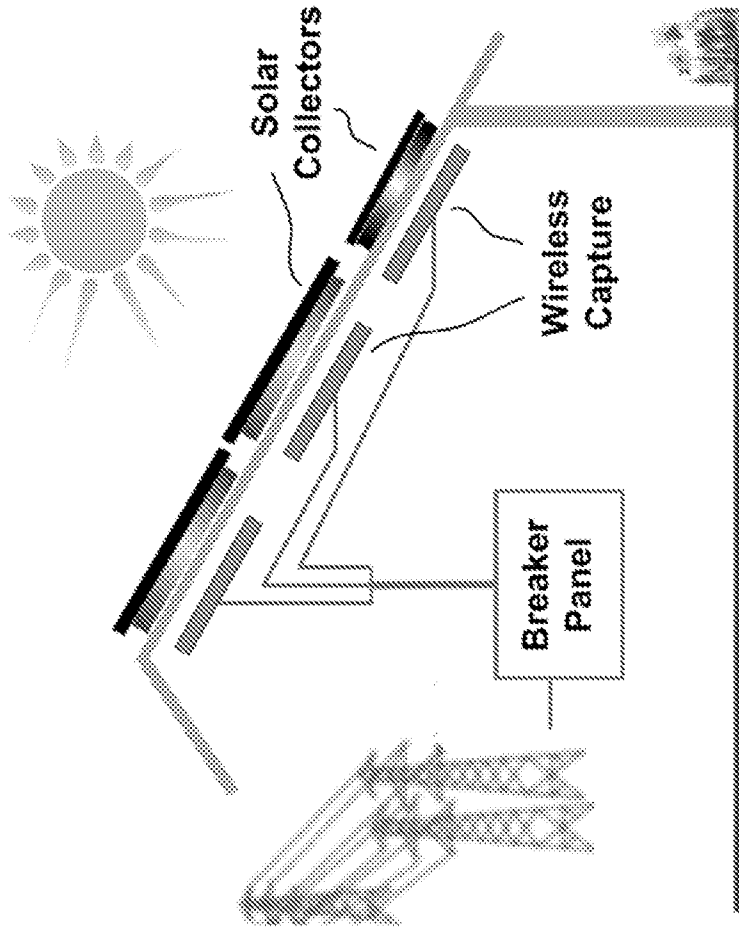

Fig. 25

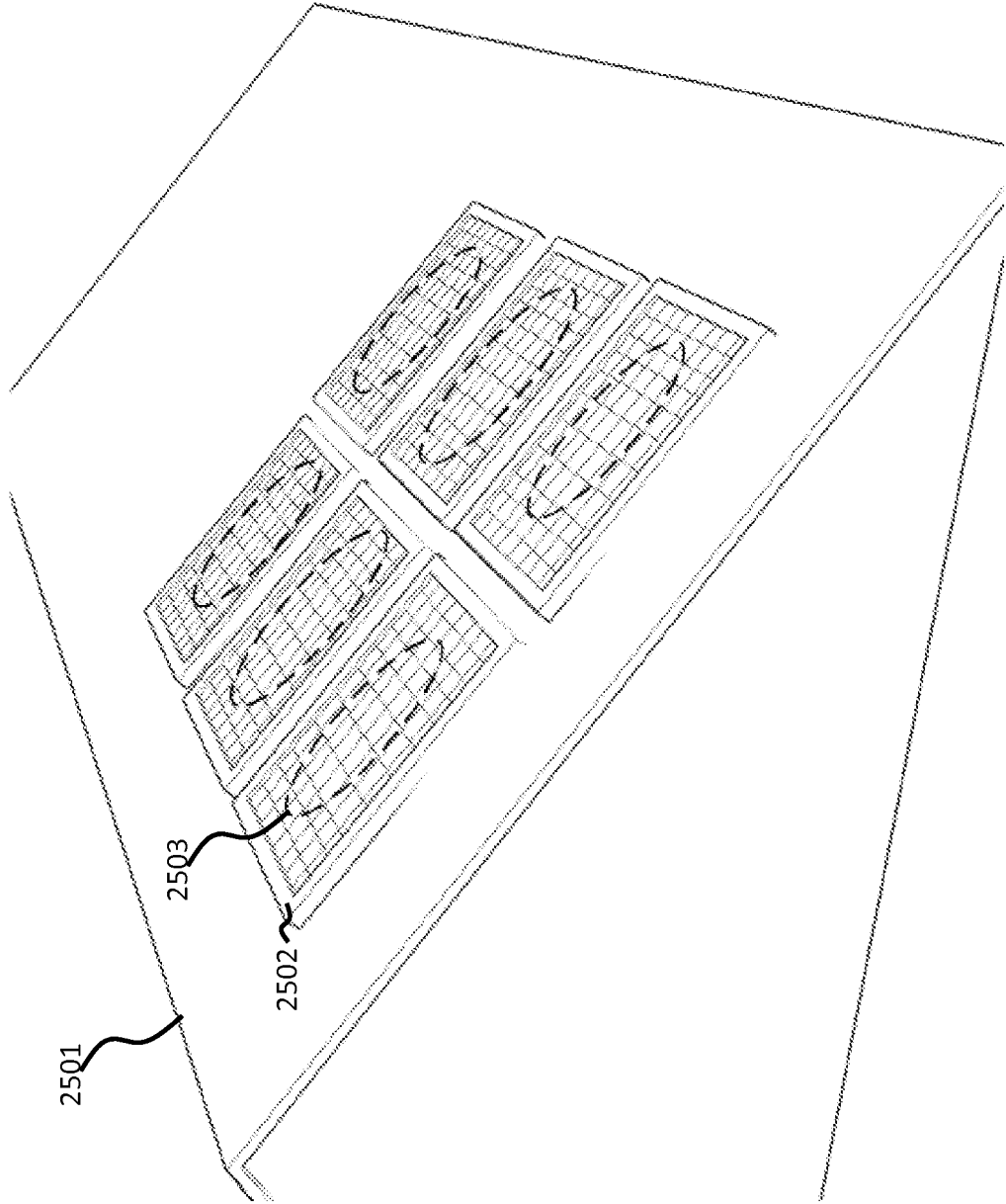

Fig. 26

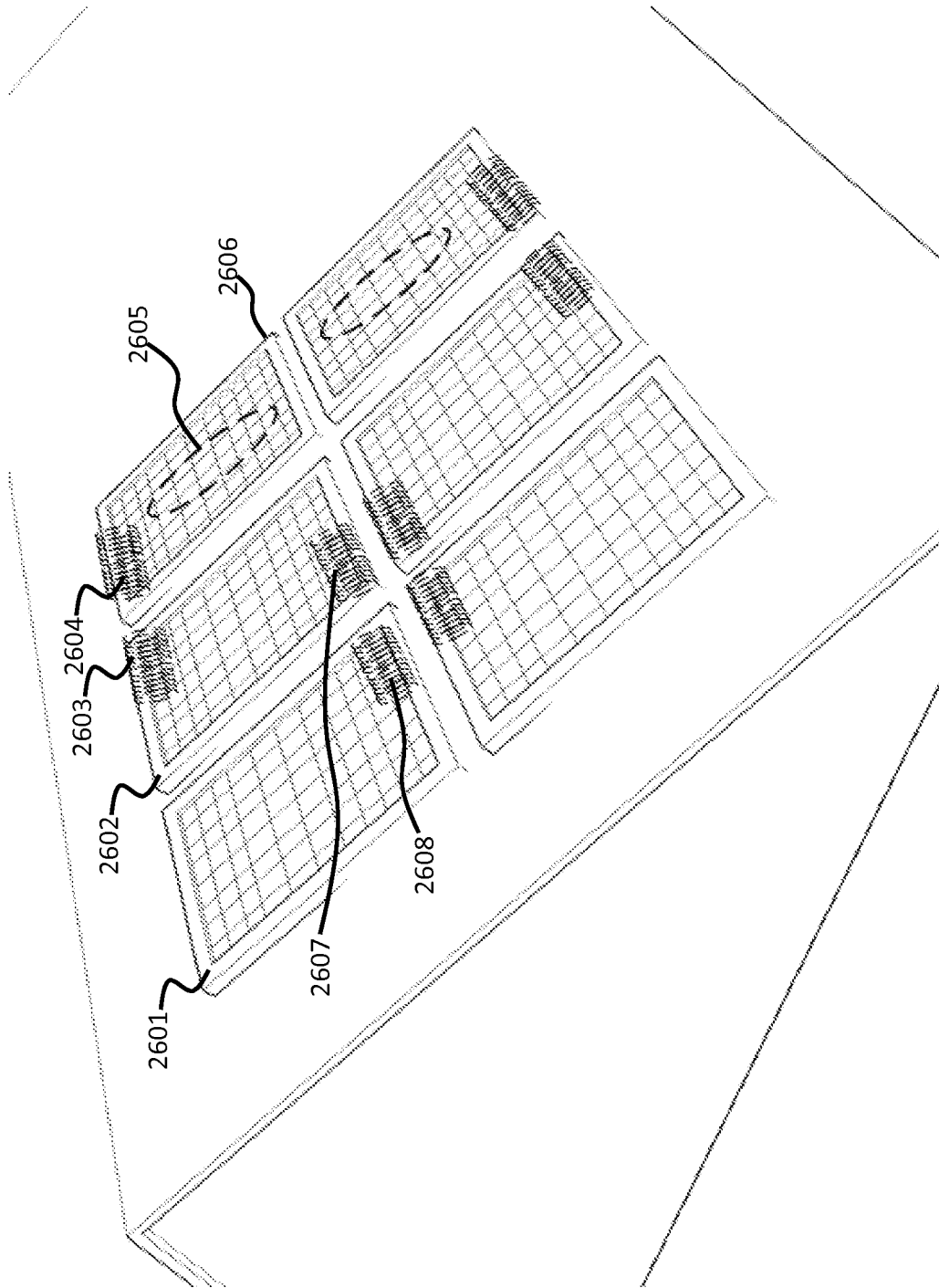
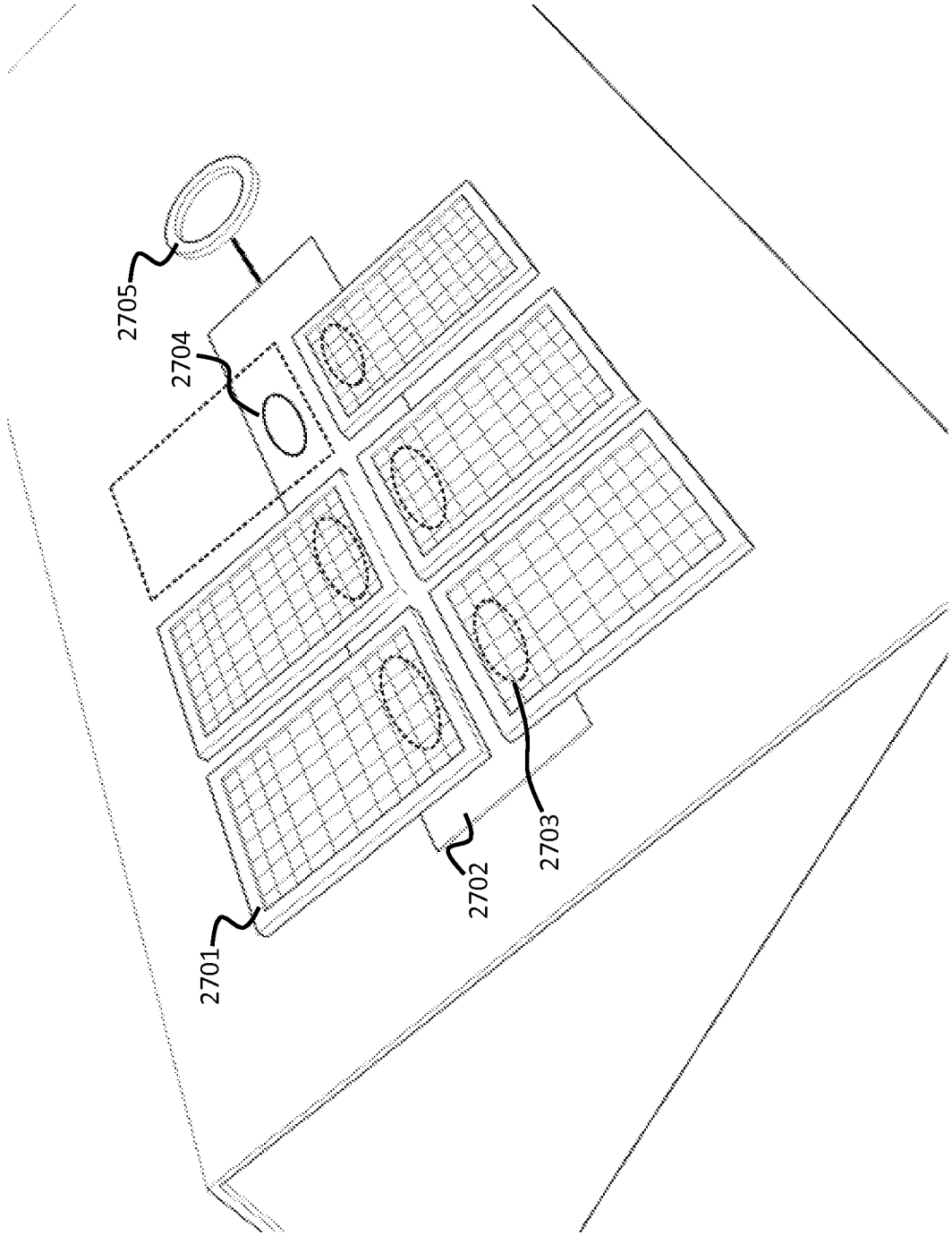

Fig. 27





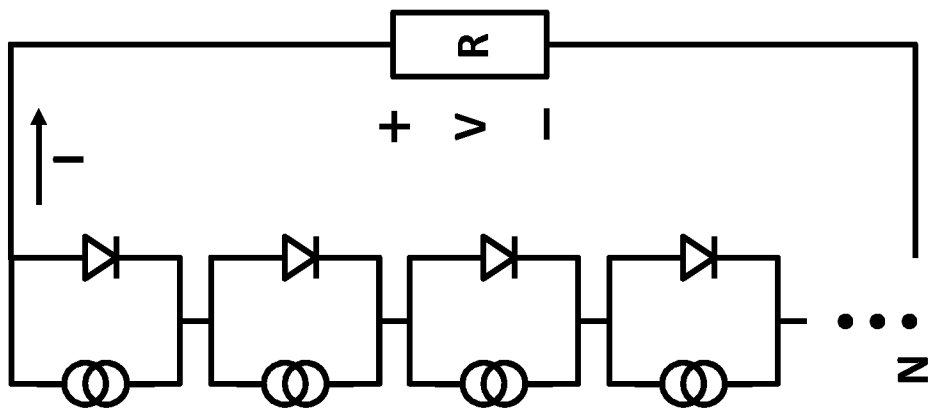

Fig. 28A

Fig. 28B

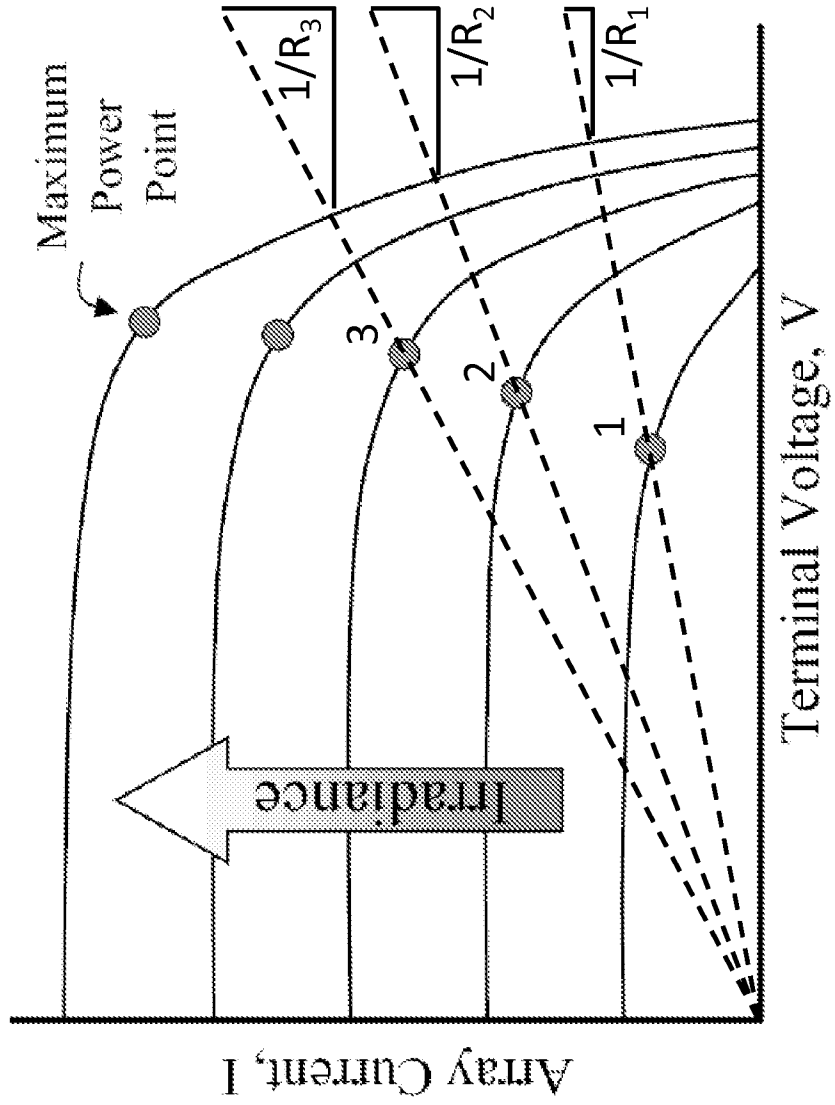

Fig. 29

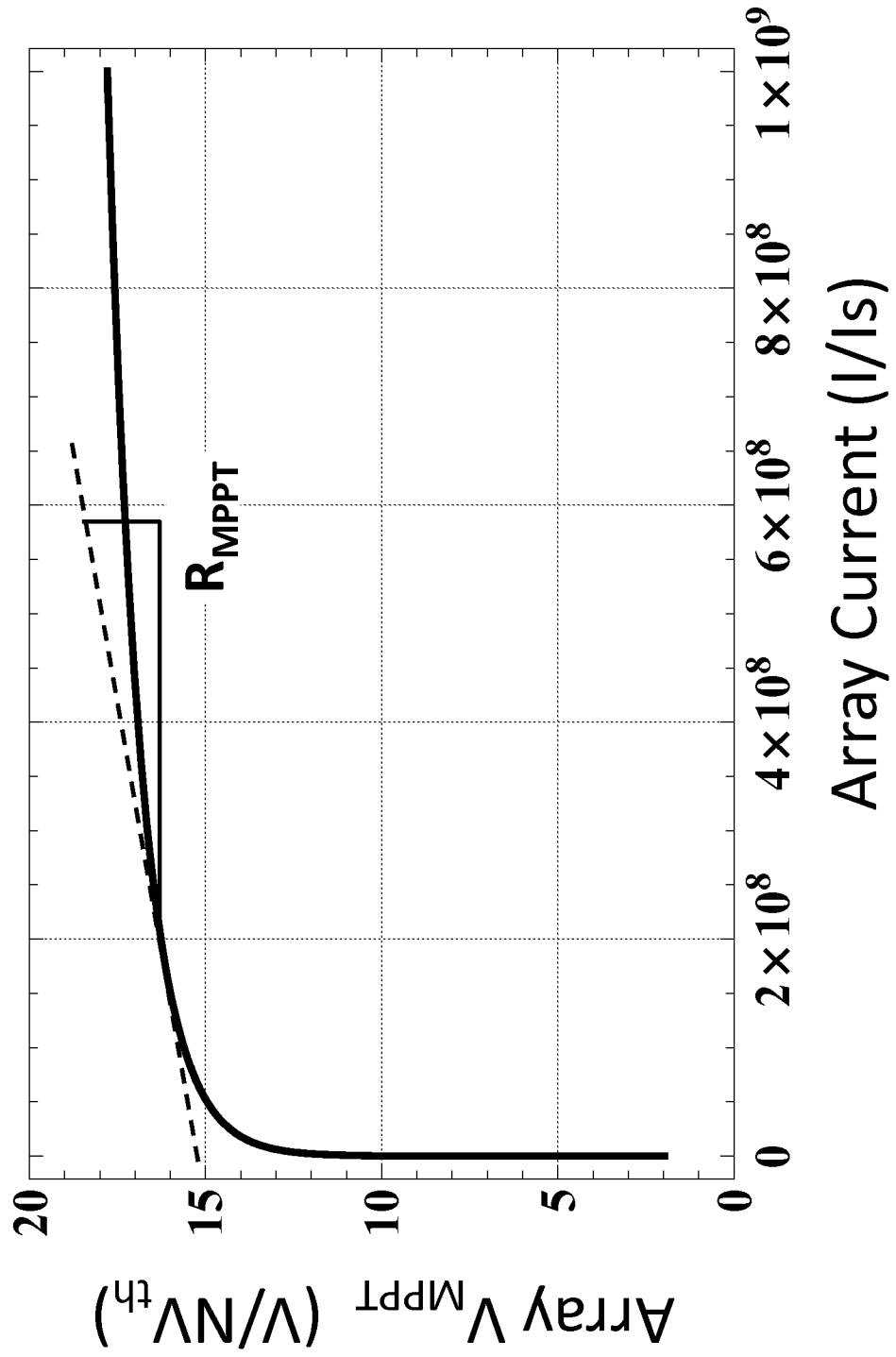

Fig. 30

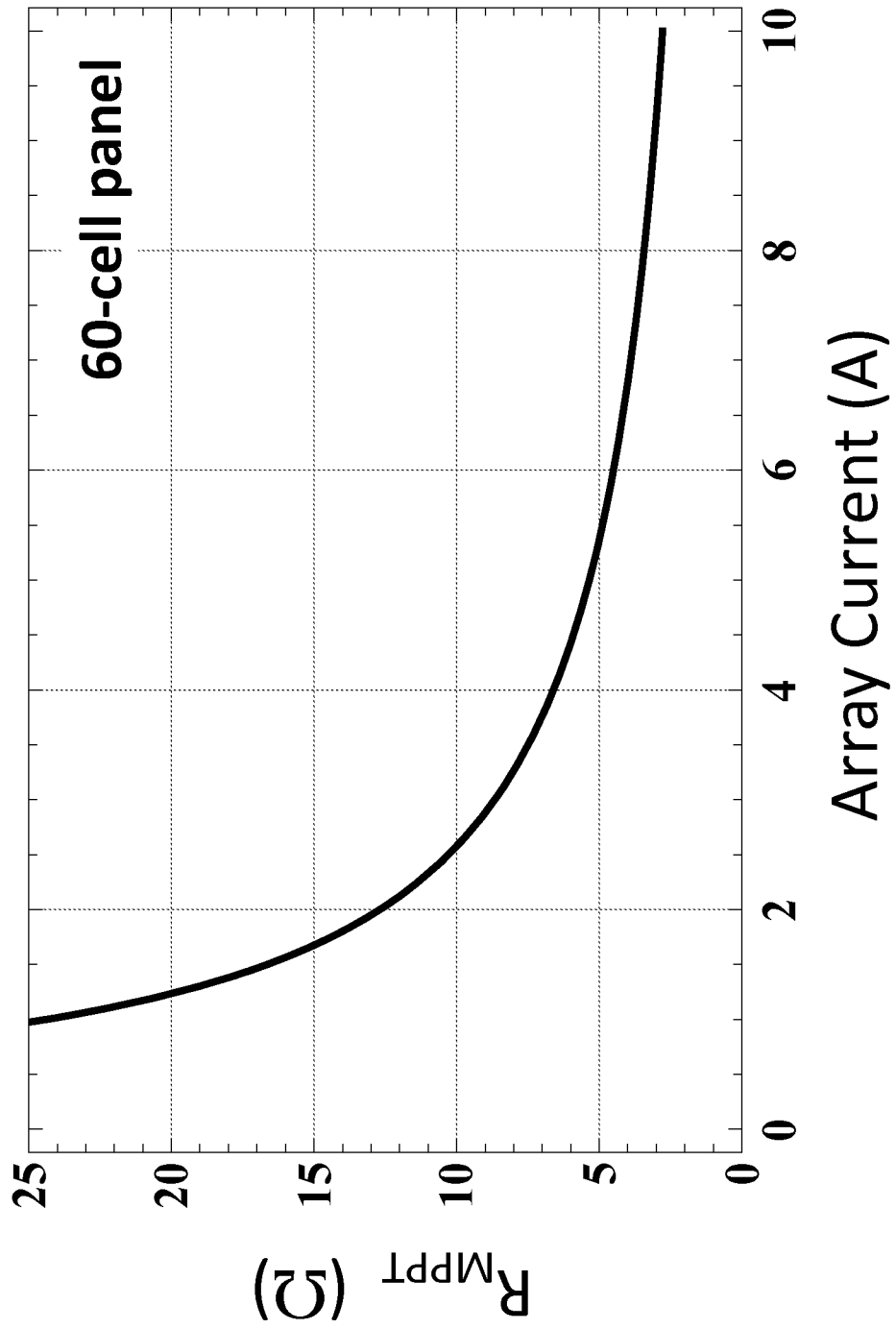

Fig. 31A

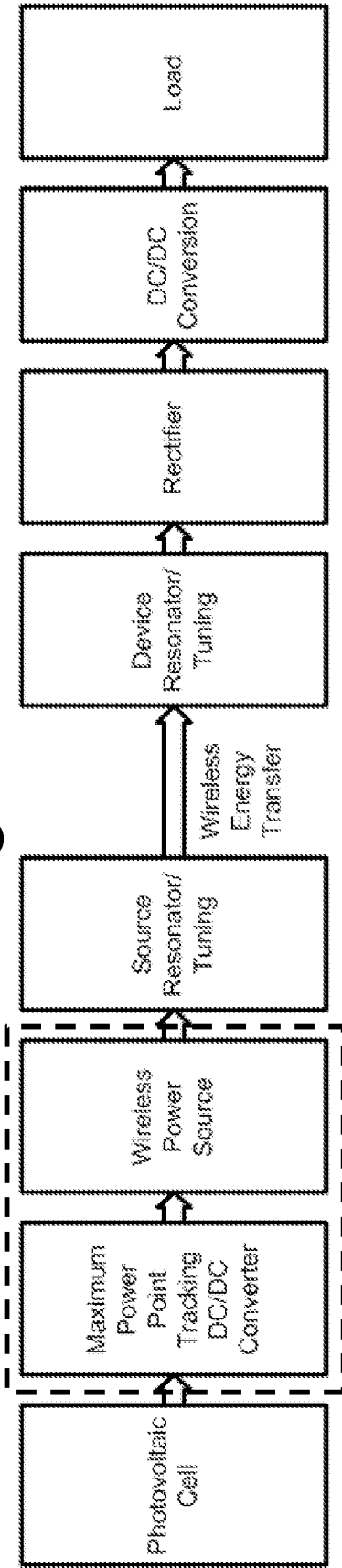

Fig. 31B

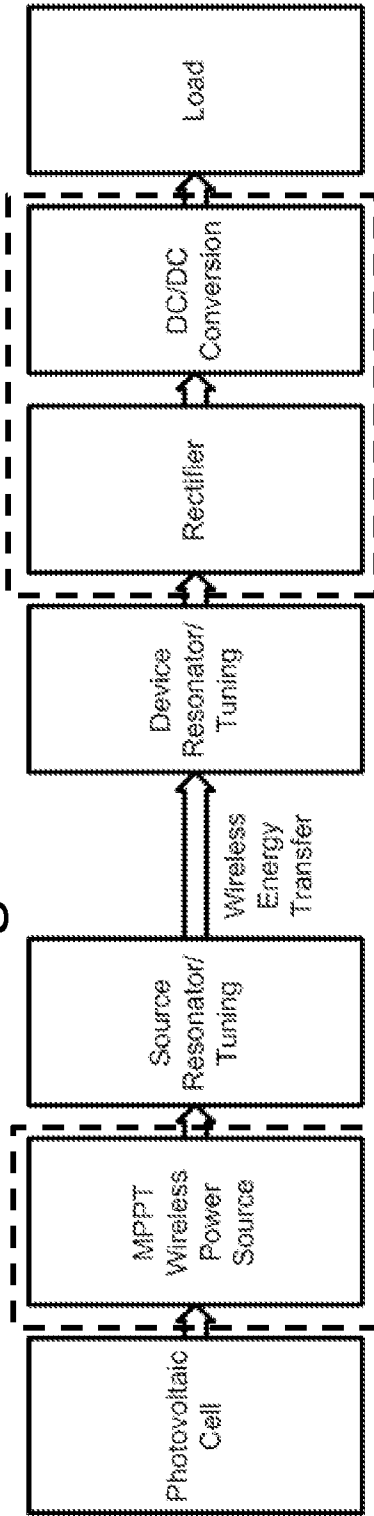

Fig. 31C

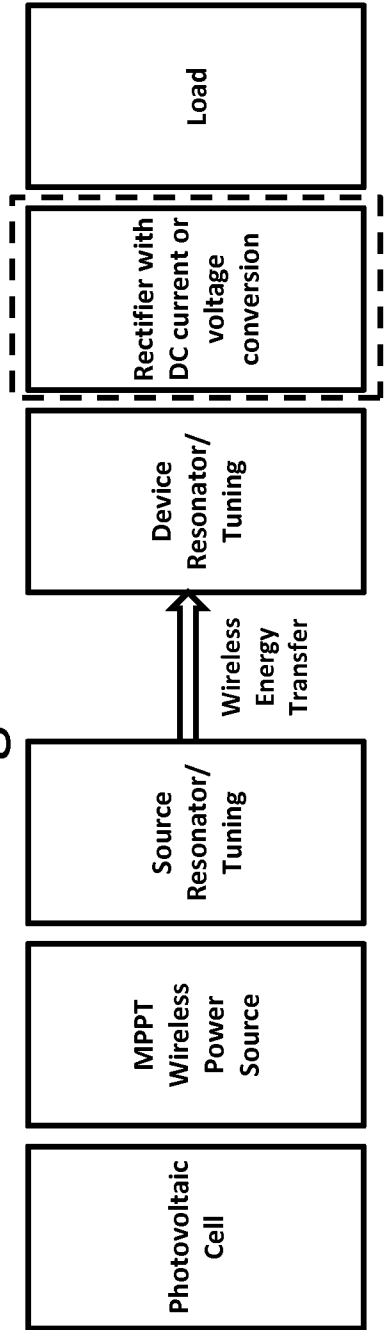

Fig. 32

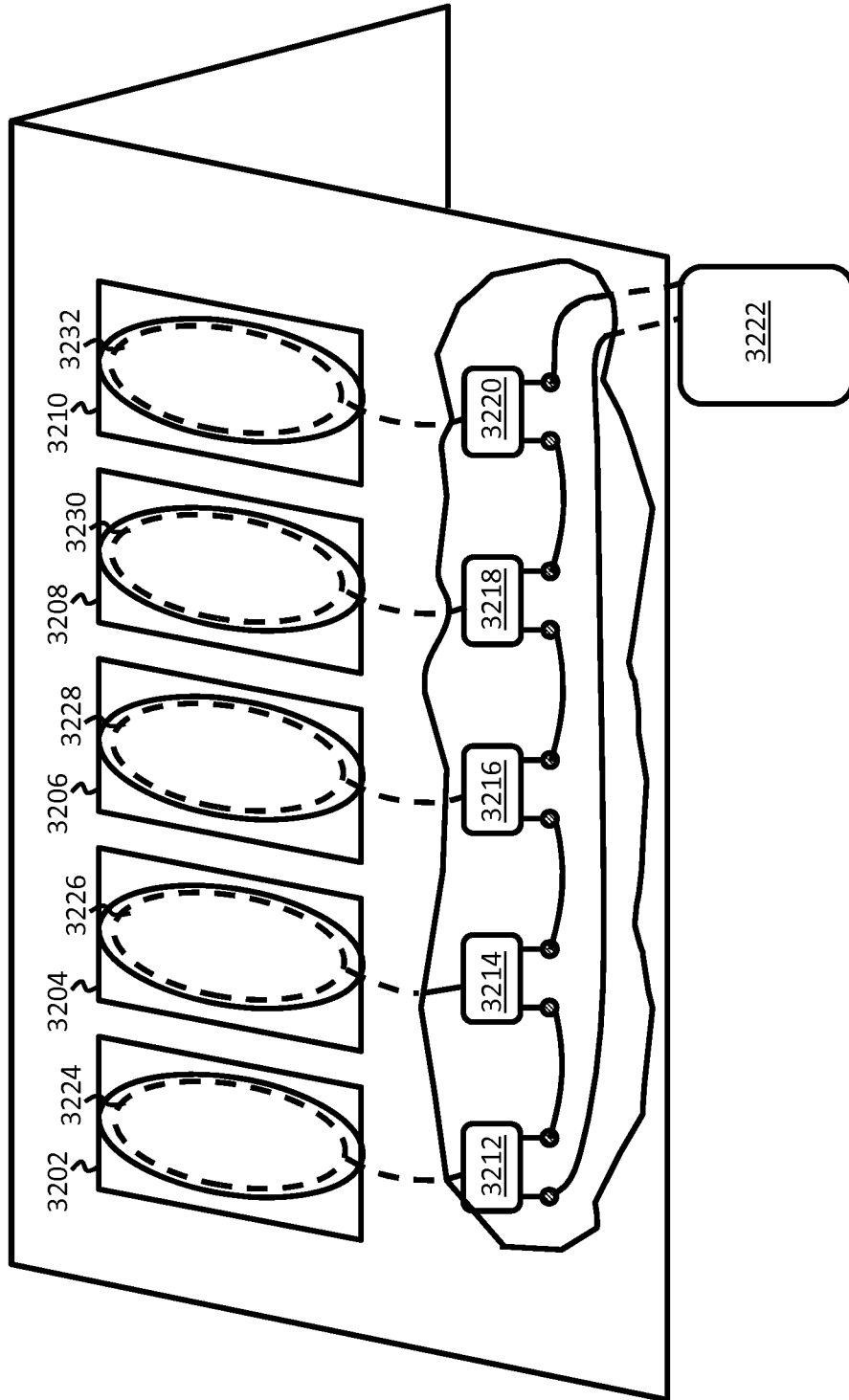

Fig. 33

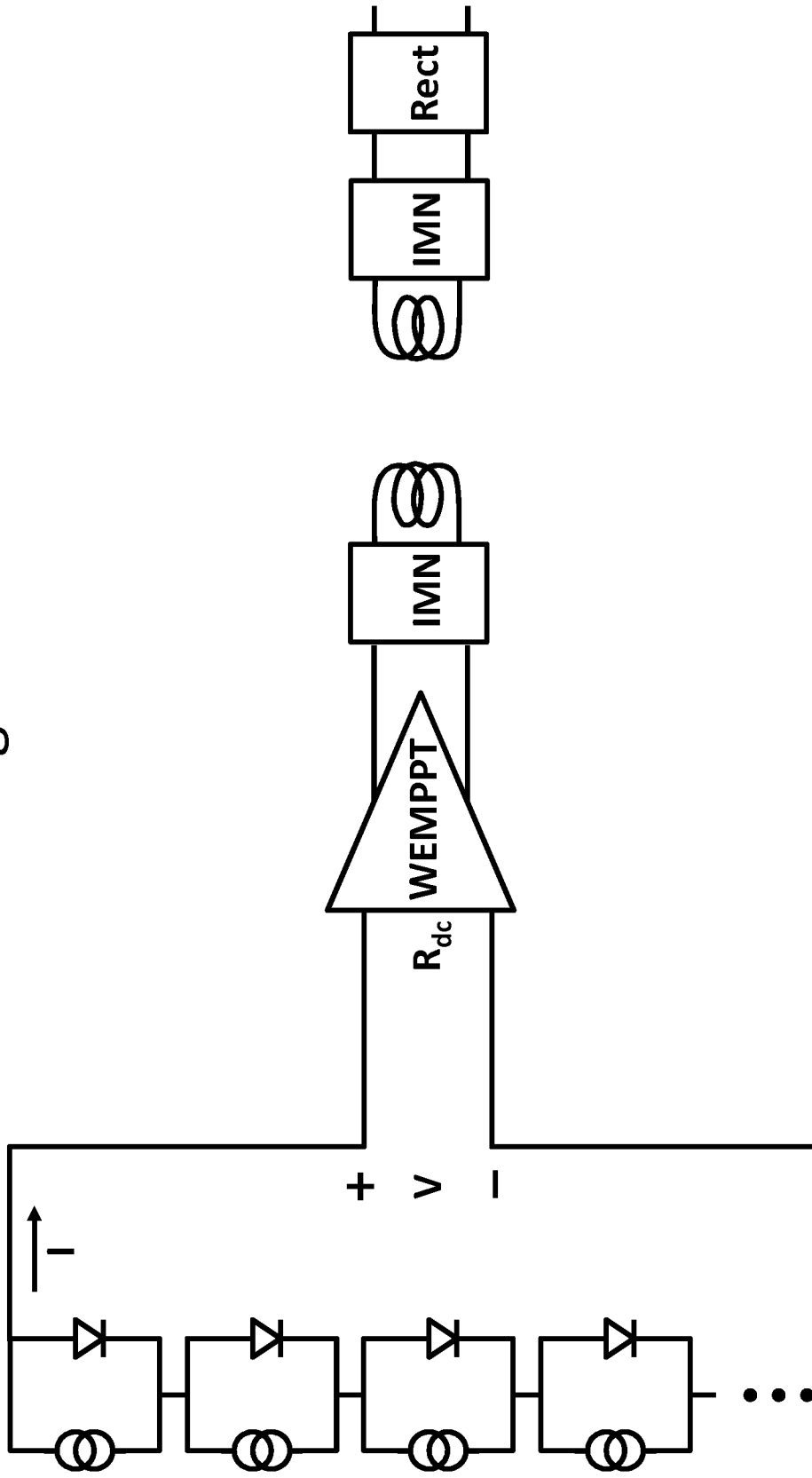

Fig. 34

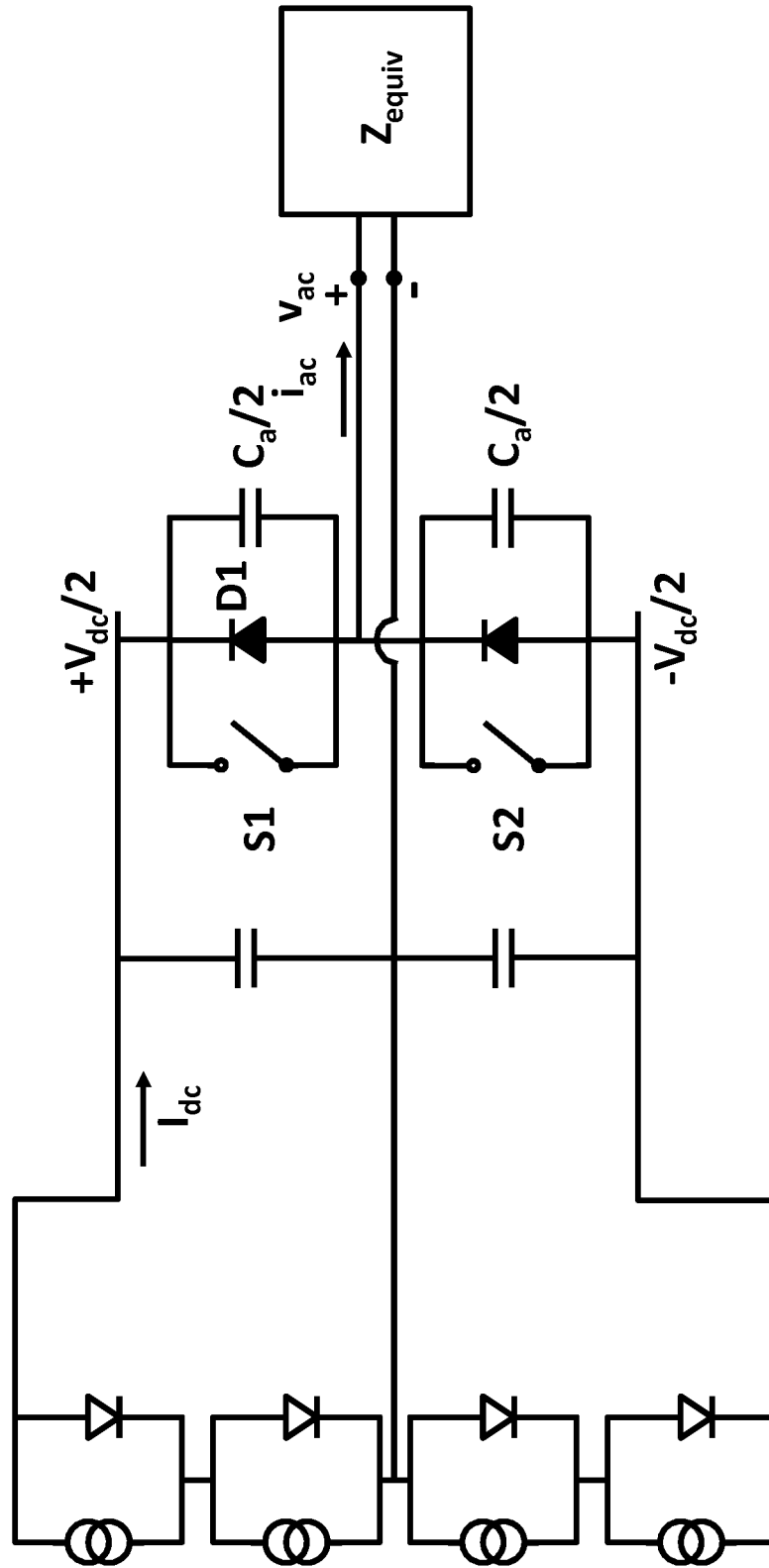



Fig. 35A

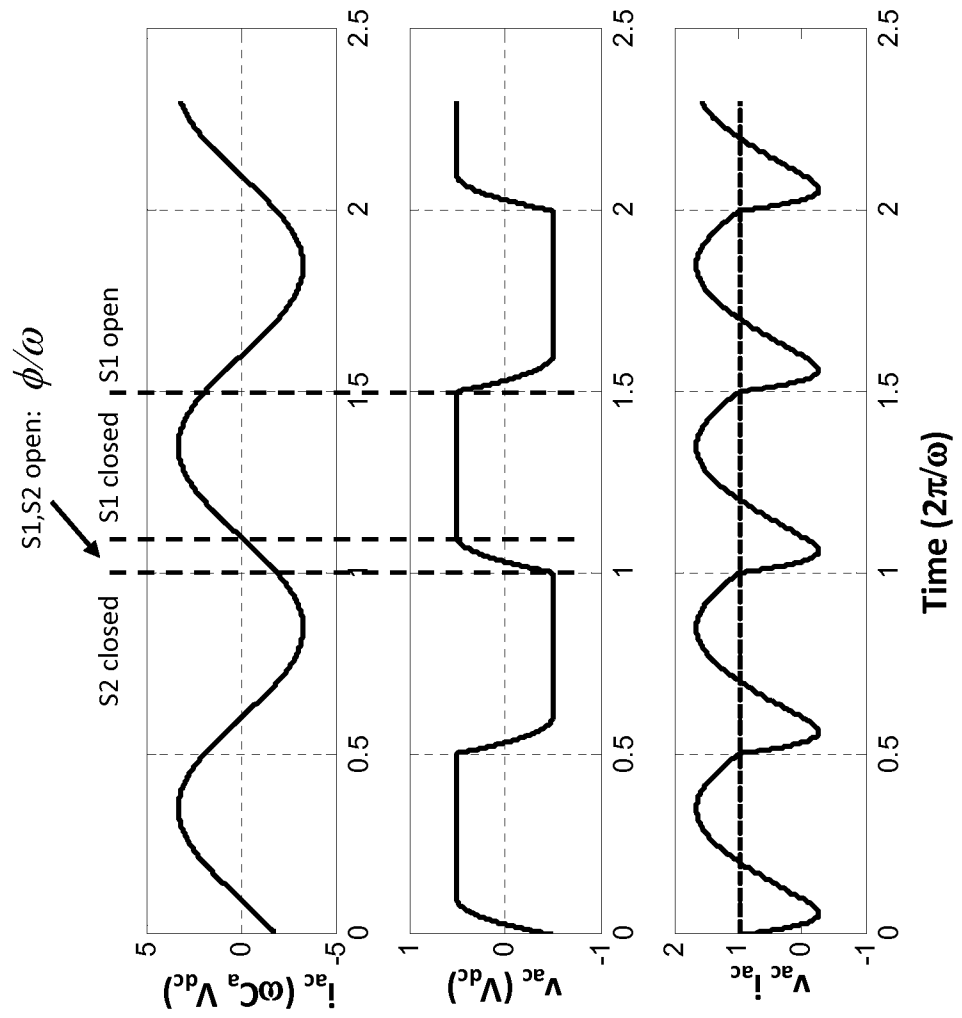

Fig. 35B

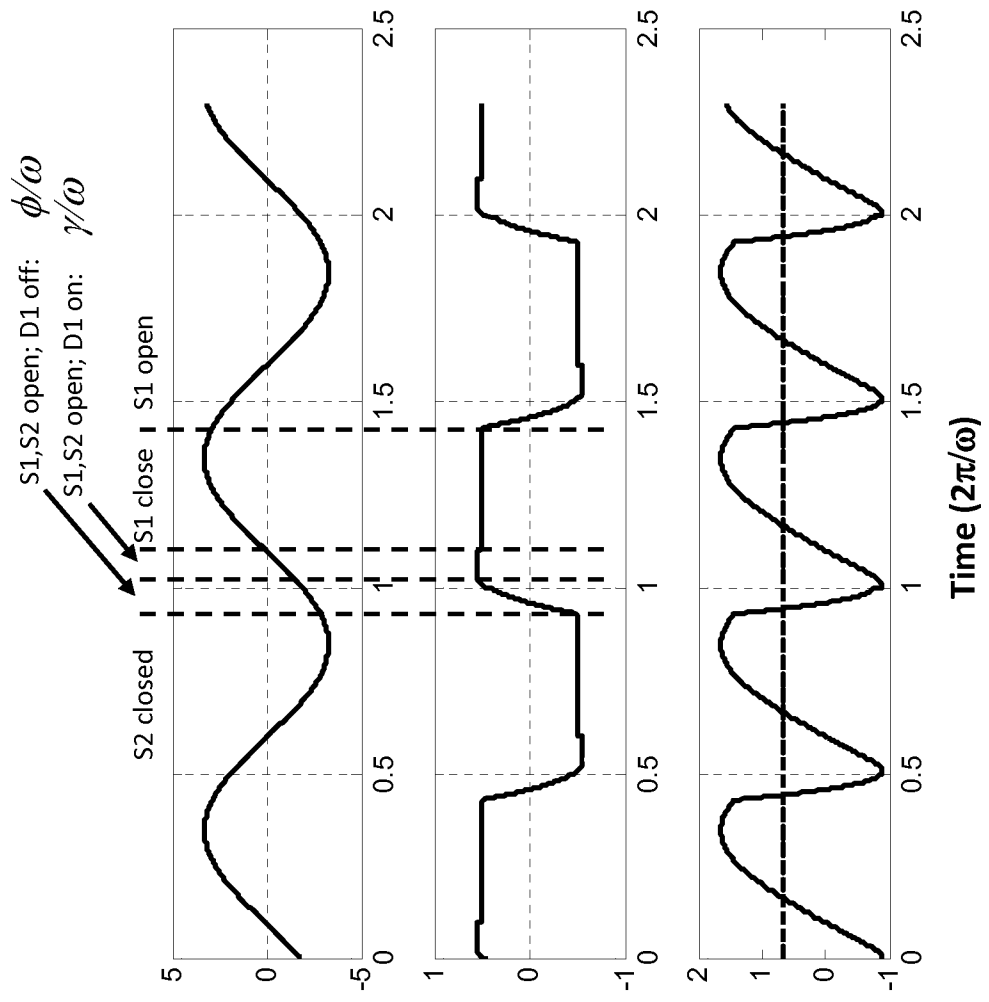

Fig. 36

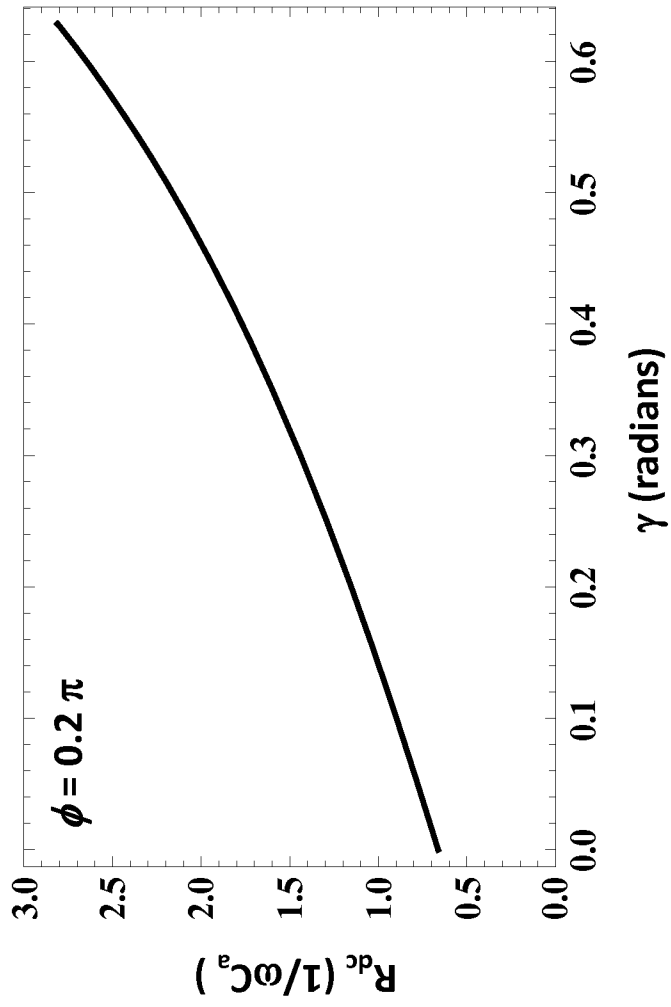

Fig. 37B

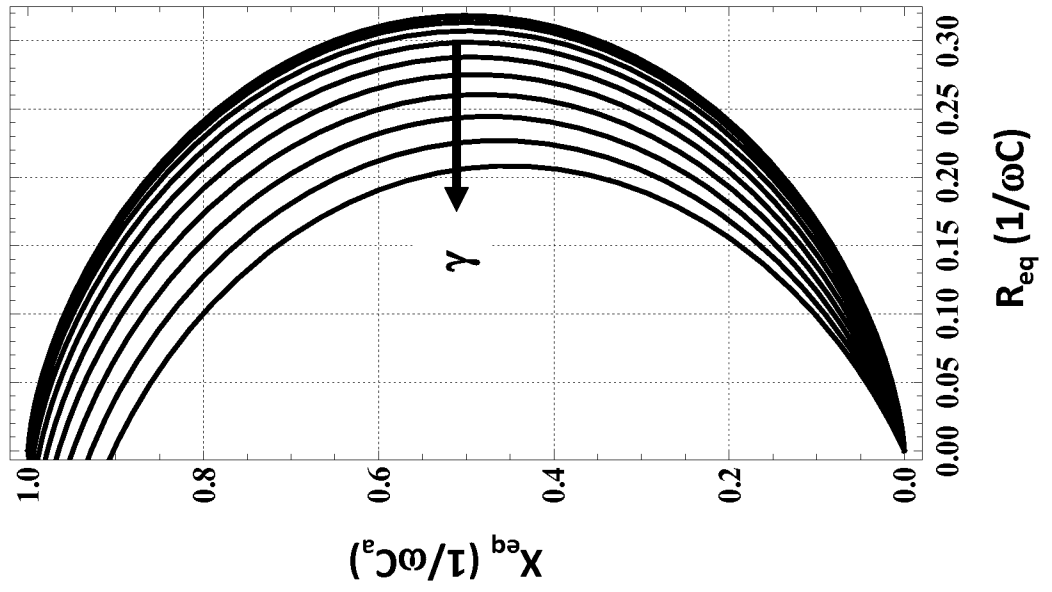

Fig. 37A

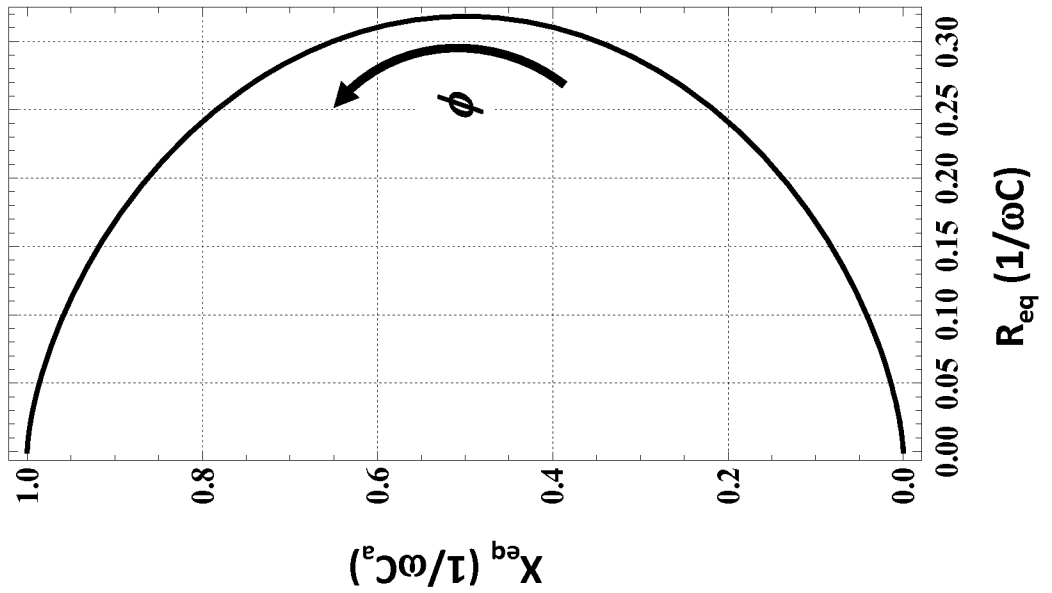

Fig. 38

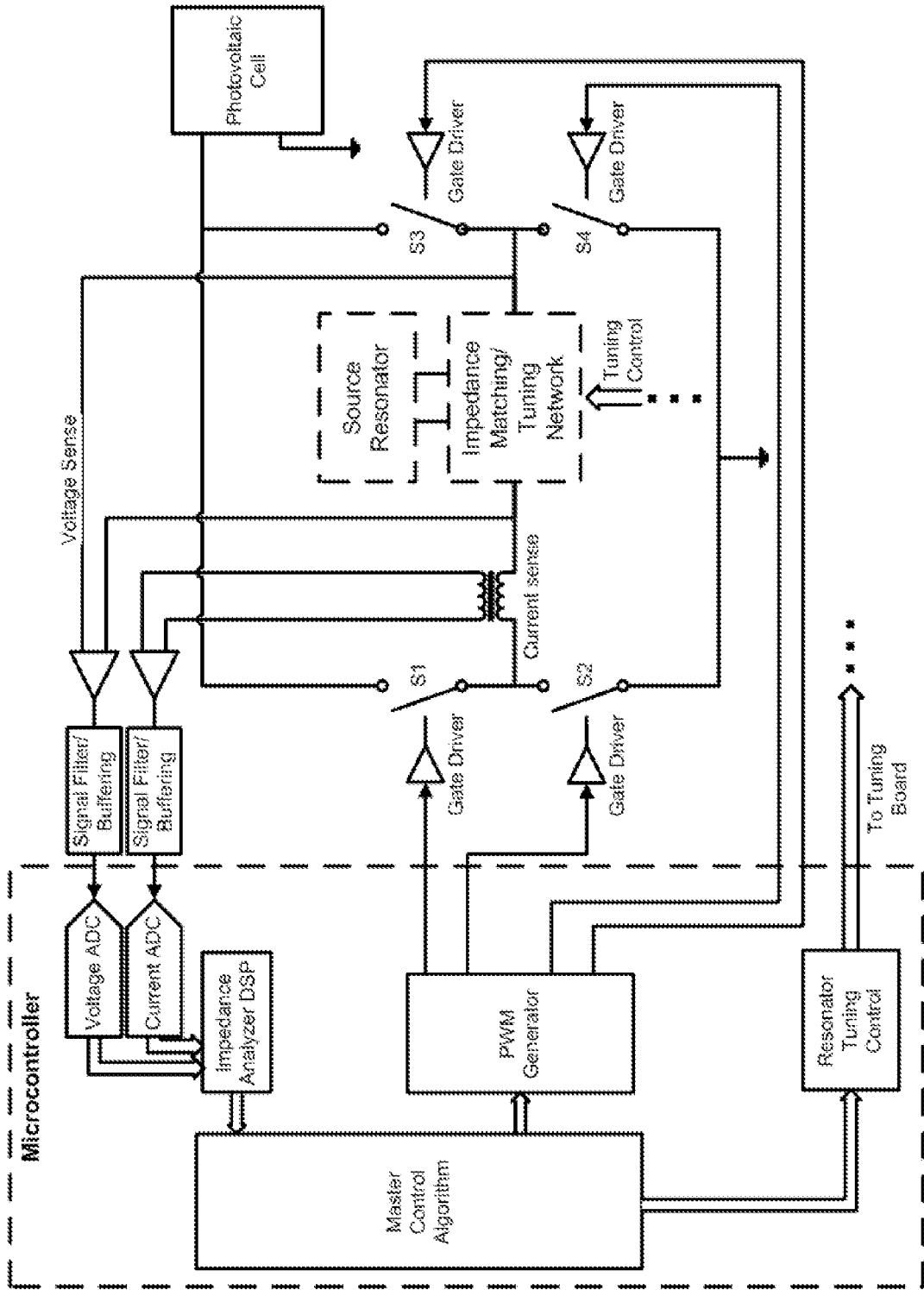

Fig. 39

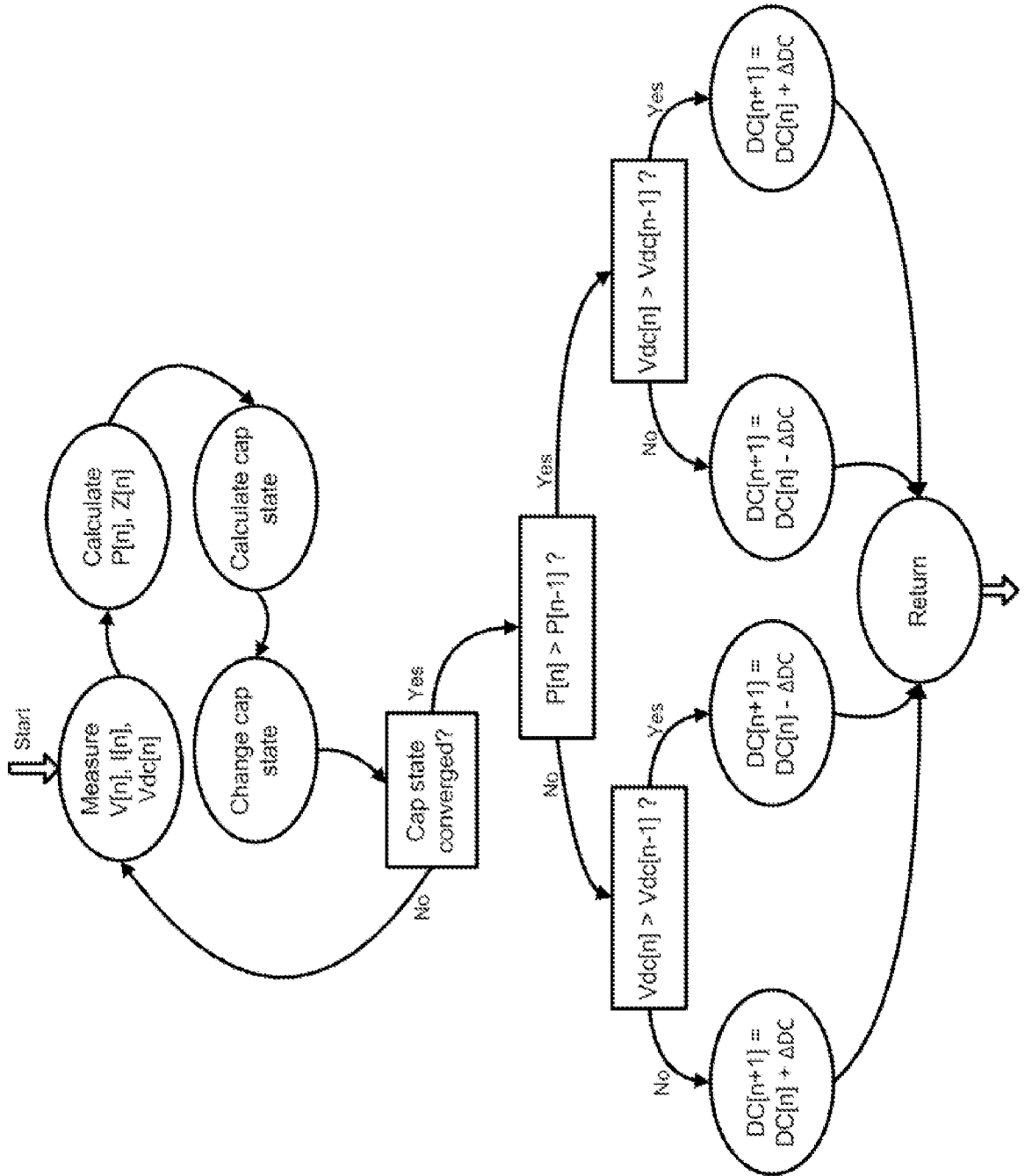

Fig. 40

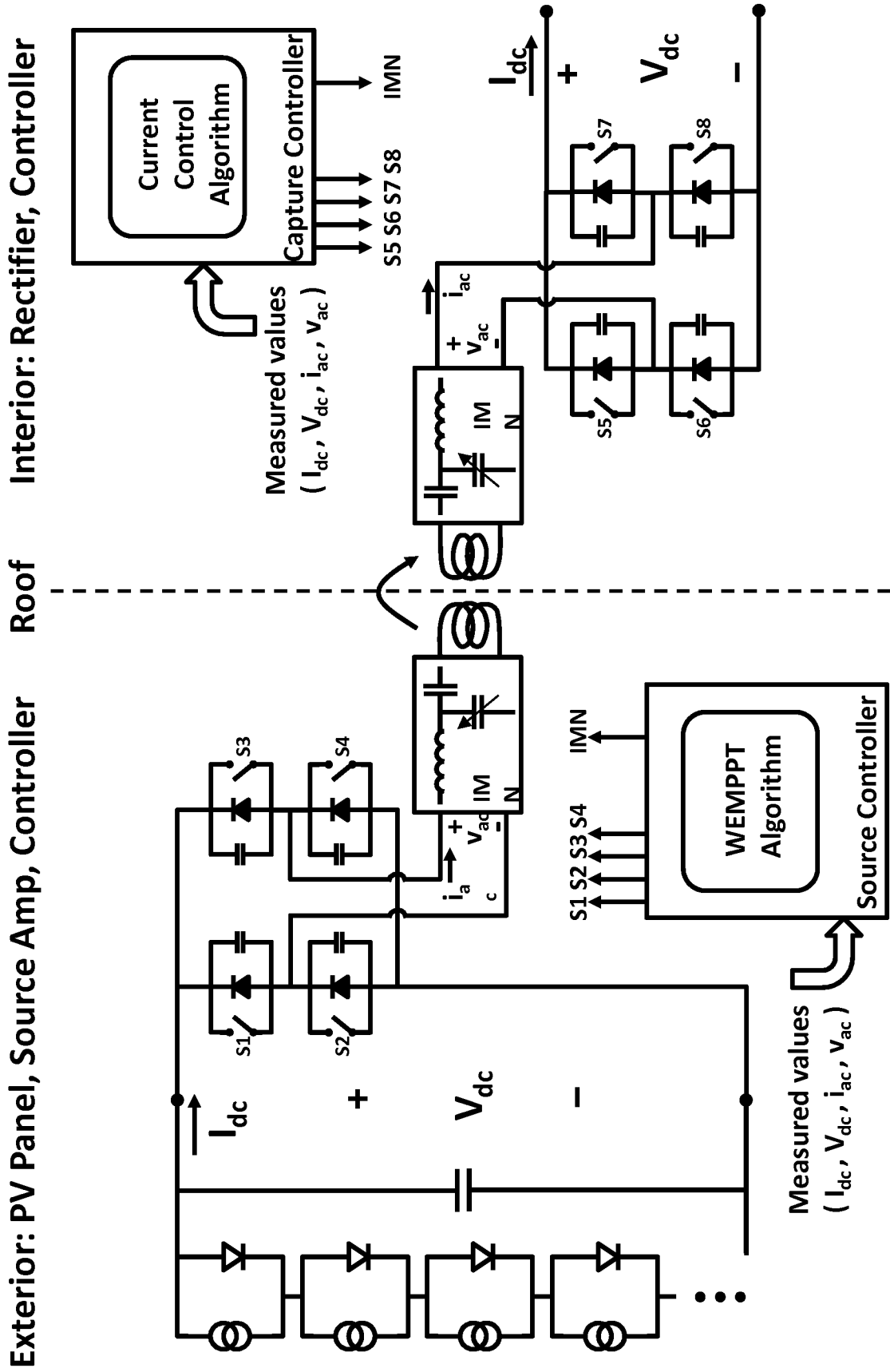
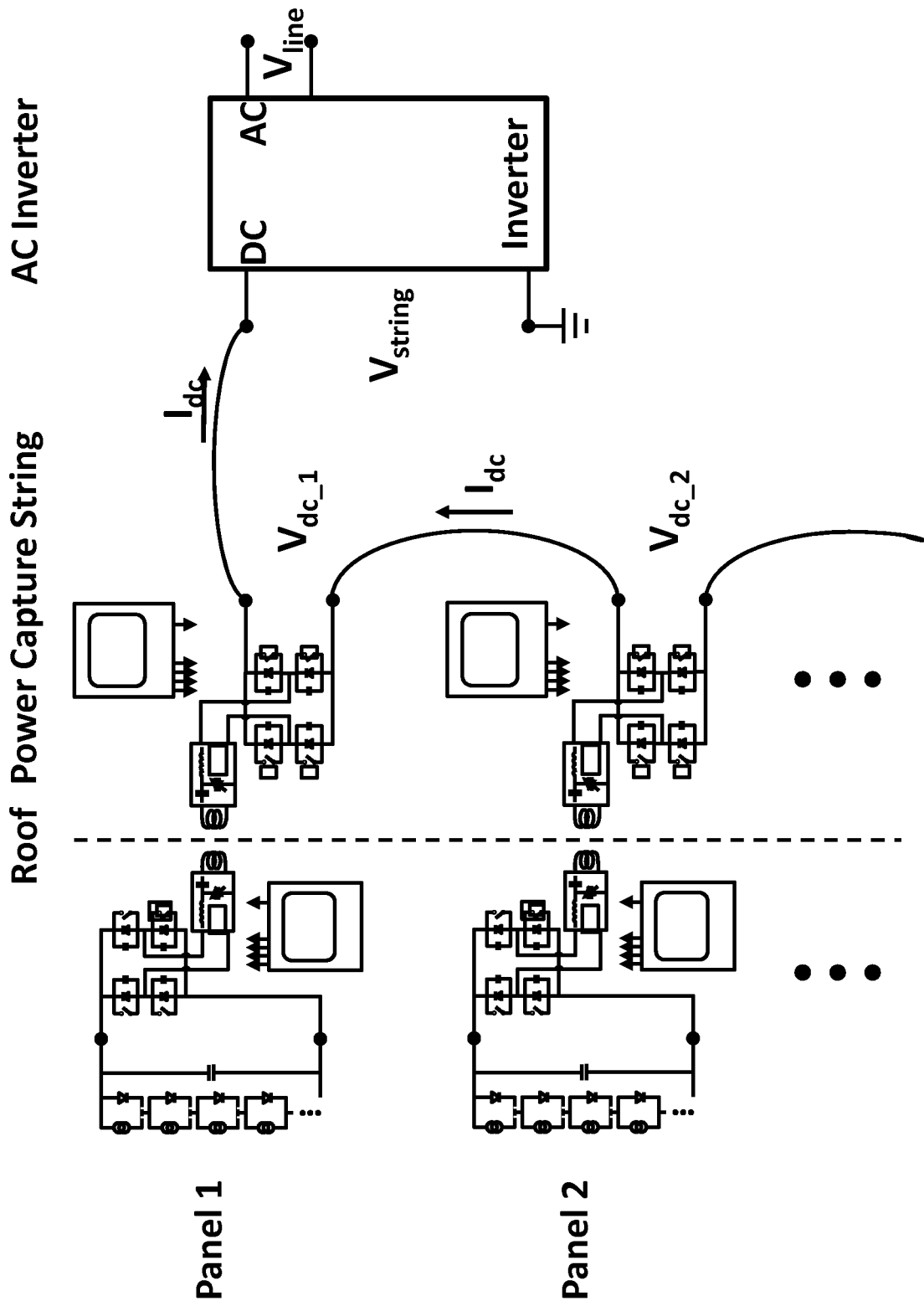
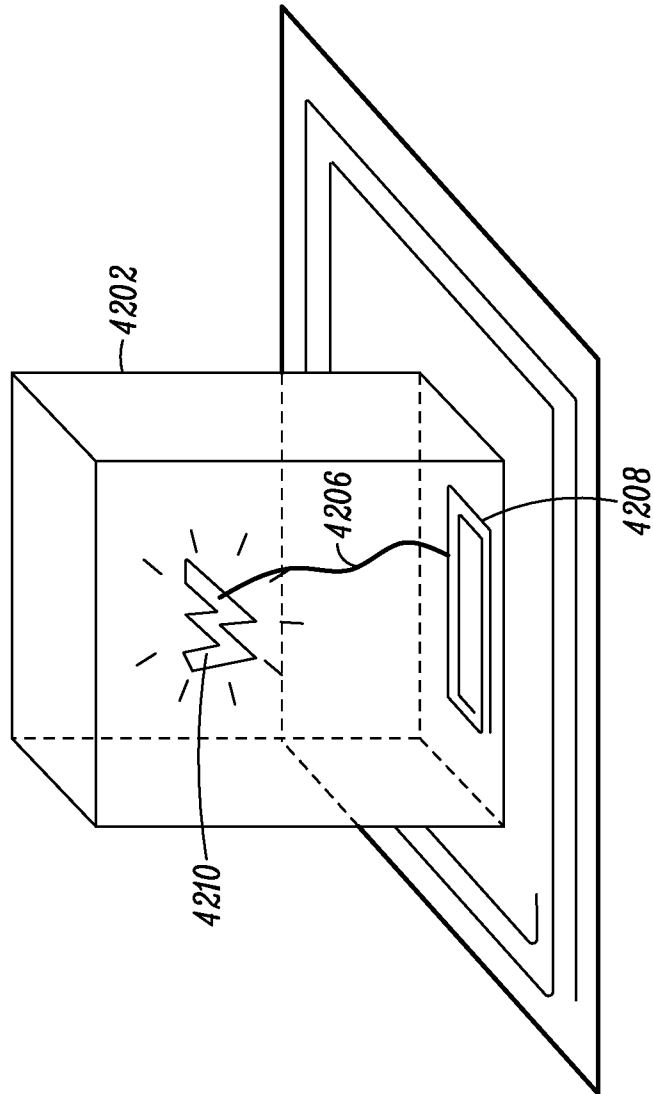

Fig. 41







**FIG. 42**

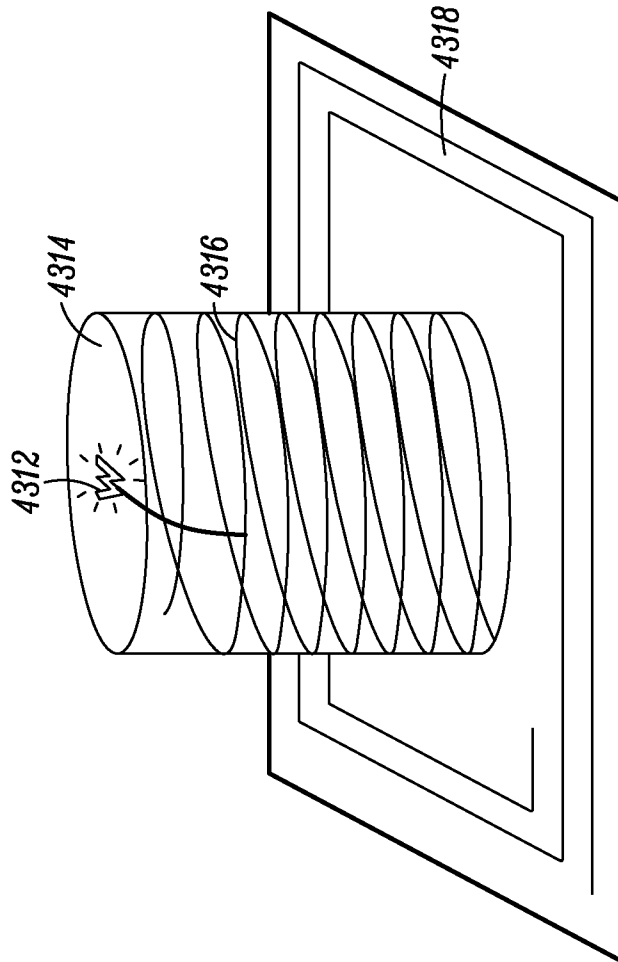

FIG. 43

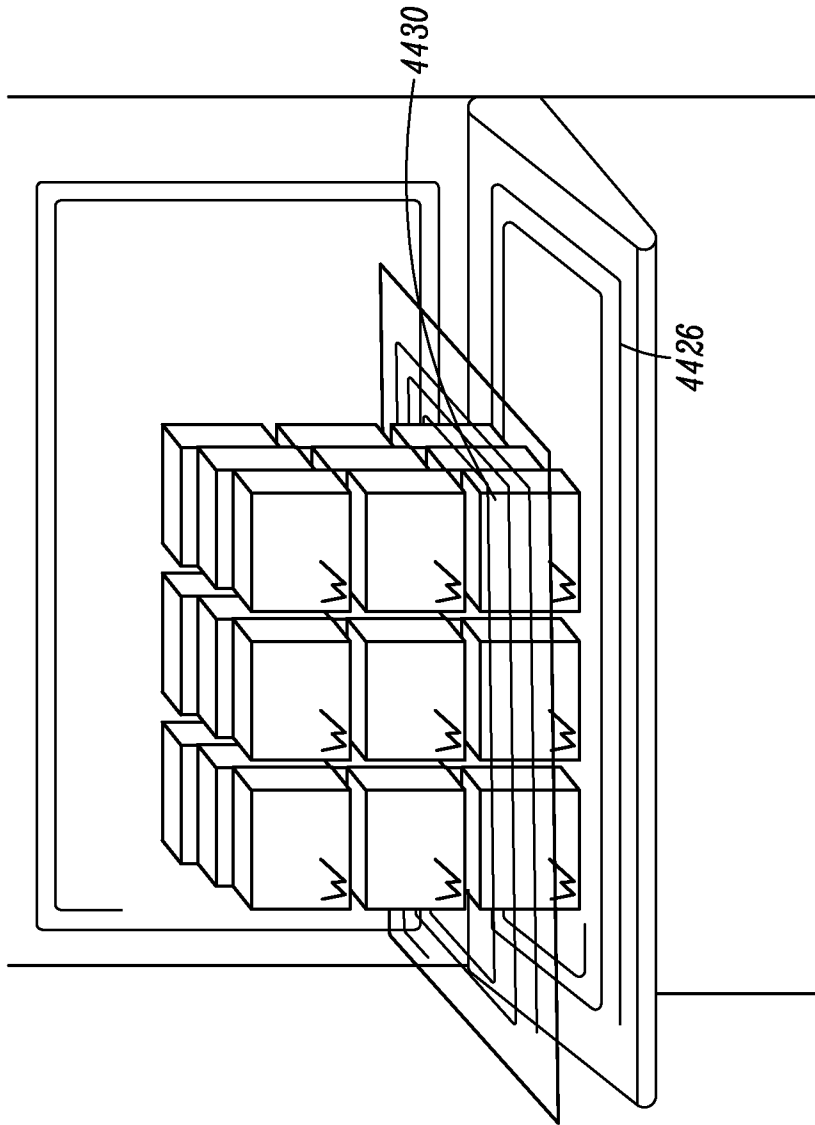

FIG. 44

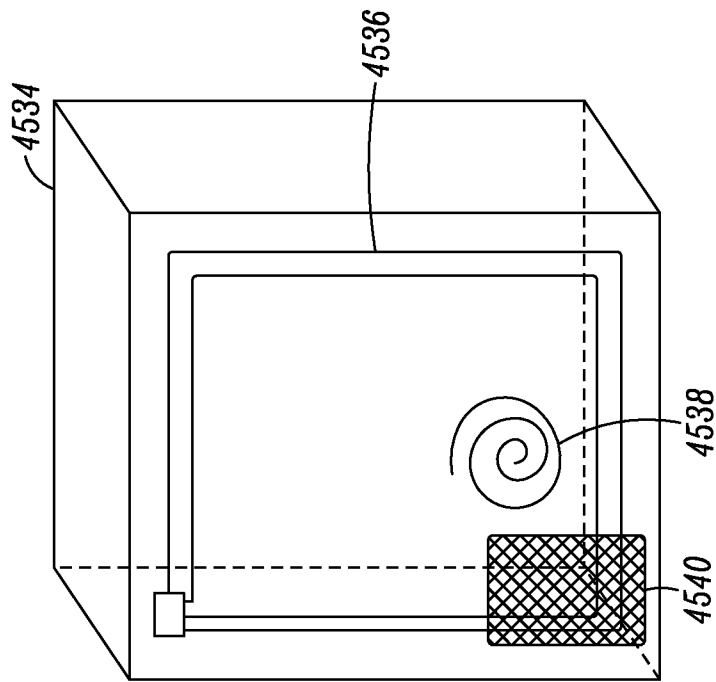

FIG. 45

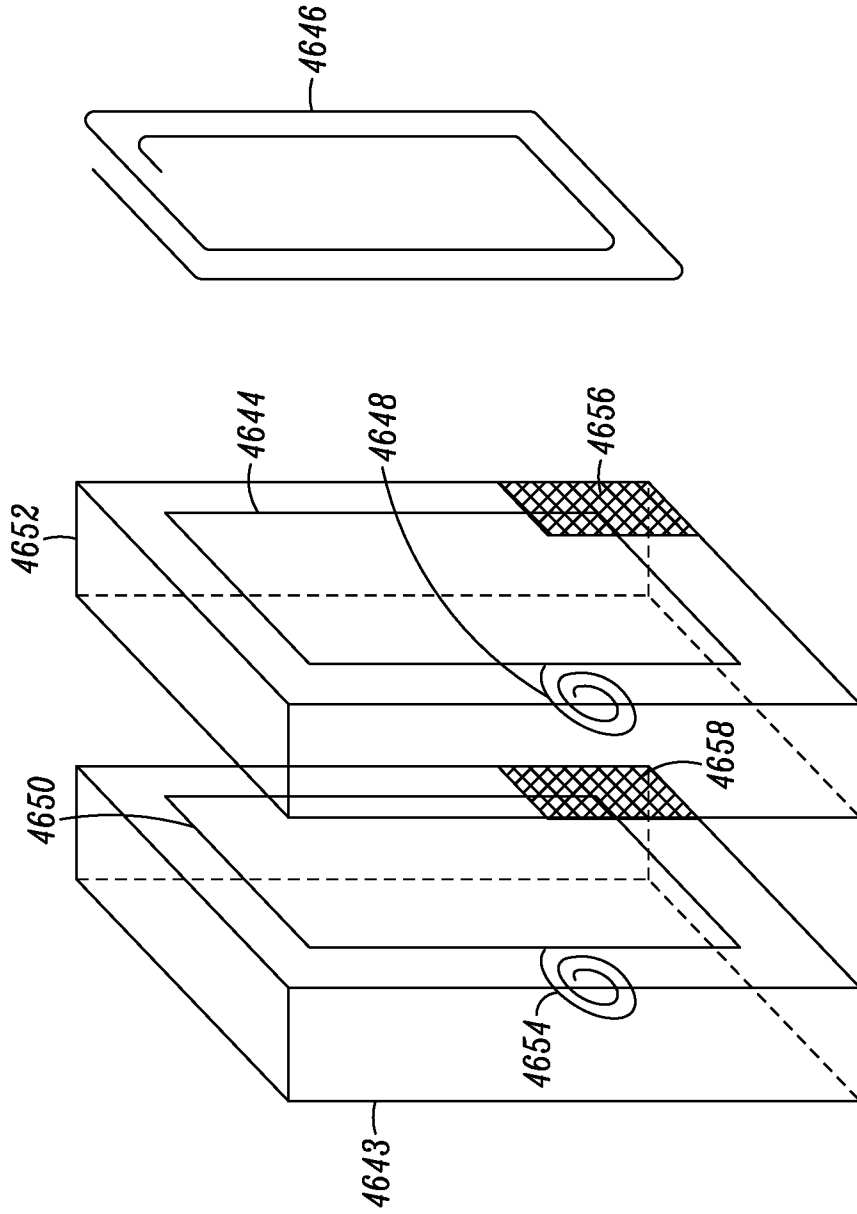

FIG. 46

## INTERNATIONAL SEARCH REPORT

International application No.  
**PCT/US2012/060793****A. CLASSIFICATION OF SUBJECT MATTER****H02J 17/00(2006.01)i, H02N 6/00(2006.01)i**

According to International Patent Classification (IPC) or to both national classification and IPC

**B. FIELDS SEARCHED**

Minimum documentation searched (classification system followed by classification symbols)

H02J 17/00; H04B 5/00; H03H 7/38; H01F 27/42; G08B 1/08; H04B 1/10

Documentation searched other than minimum documentation to the extent that such documents are included in the fields searched

Korean utility models and applications for utility models  
Japanese utility models and applications for utility models

Electronic data base consulted during the international search (name of data base and, where practicable, search terms used)

eKOMPASS(KIPO internal) &amp; Keywords: wireless energy transfer, dynamic, impedance matching

**C. DOCUMENTS CONSIDERED TO BE RELEVANT**

Category*	Citation of document, with indication, where appropriate, of the relevant passages	Relevant to claim No.
X	WO 2011-112795 A1 (WITRICITY CORPORATION et al.) 15 September 2011 See abstract, paragraphs [0011], [0031], [0104], [0118]-[0119], [0133]-[0134]	1-8, 10-25
A	, [0142] and figure 4.	9
A	US 2009-0085408 A1 (BRUHN ALFRED) 02 April 2009 See abstract, paragraphs [0017]-[0018], [0031] and figure 19.	1-25
A	US 2011-0248573 A1 (KANNO HIROSHI et al.) 13 October 2011 See abstract, paragraphs [0050]-[0053] and figure 7.	1-25
A	KR 10-2008-0007635 A (MICROTUNE (TEXAS), L. P.) 22 January 2008 See page 6, lines 7-35 and figure 1.	1-25
A	US 2008-0036588 A1 (ROD IVERSON et al.) 14 February 2008 See paragraphs [0005], [0019] and figure 3.	1-25

 Further documents are listed in the continuation of Box C. See patent family annex.

\* Special categories of cited documents:

"A" document defining the general state of the art which is not considered to be of particular relevance

"E" earlier application or patent but published on or after the international filing date

"L" document which may throw doubts on priority claim(s) or which is cited to establish the publication date of citation or other special reason (as specified)

"O" document referring to an oral disclosure, use, exhibition or other means

"P" document published prior to the international filing date but later than the priority date claimed

"T" later document published after the international filing date or priority date and not in conflict with the application but cited to understand the principle or theory underlying the invention

"X" document of particular relevance; the claimed invention cannot be considered novel or cannot be considered to involve an inventive step when the document is taken alone

"Y" document of particular relevance; the claimed invention cannot be considered to involve an inventive step when the document is combined with one or more other such documents, such combination being obvious to a person skilled in the art

"&amp;" document member of the same patent family

Date of the actual completion of the international search

07 MARCH 2013 (07.03.2013)

Date of mailing of the international search report

**08 MARCH 2013 (08.03.2013)**

Name and mailing address of the ISA/KR

Korean Intellectual Property Office  
189 Cheongsa-ro, Seo-gu, Daejeon Metropolitan  
City, 302-701, Republic of Korea

Facsimile No. 82-42-472-7140

Authorized officer

CHOI, Jeong Yoon

Telephone No. 82-42-481-8153



## INTERNATIONAL SEARCH REPORT

Information on patent family members

International application No.

**PCT/US2012/060793**

Patent document cited in search report	Publication date	Patent family member(s)	Publication date
WO 2011-112795 A1	15.09.2011	AU 2009-296413 A1	01.04.2010
		AU 2010-213557 A1	19.08.2010
		CA 2738654 A1	01.04.2010
		CA 2752573 A1	19.08.2010
		CA 2792256 A1	15.09.2011
		CN 102239633 A	09.11.2011
		CN 102439669 A	02.05.2012
		JP 2012-504387 A	16.02.2012
		JP 2012-518382 A	09.08.2012
		KR 10-2011-0074761 A	01.07.2011
		KR 10-2011-0127203 A	24.11.2011
		US 2010-0109445 A1	06.05.2010
		US 2010-0141042 A1	10.06.2010
		US 2010-0164296 A1	01.07.2010
		US 2010-0164297 A1	01.07.2010
		US 2010-0164298 A1	01.07.2010
		US 2010-0171368 A1	08.07.2010
		US 2010-0181843 A1	22.07.2010
		US 2010-0181845 A1	22.07.2010
		US 2010-0201203 A1	12.08.2010
		US 2010-0219694 A1	02.09.2010
		US 2010-0231340 A1	16.09.2010
		US 2010-0237709 A1	23.09.2010
		US 2010-0259108 A1	14.10.2010
		US 2010-0259110 A1	14.10.2010
		US 2010-0264747 A1	21.10.2010
		US 2010-0277121 A1	04.11.2010
		US 2010-0308939 A1	09.12.2010
		US 2011-0043047 A1	24.02.2011
		US 2011-0043048 A1	24.02.2011
		US 2011-0043049 A1	24.02.2011
		US 2011-0074346 A1	31.03.2011
		US 2011-0095618 A1	28.04.2011
		US 2011-0121920 A1	26.05.2011
		US 2011-0193416 A1	11.08.2011
		US 2012-0032522 A1	09.02.2012
		US 2012-0062345 A1	15.03.2012
		US 2012-0139355 A1	07.06.2012
		US 2012-0280765 A1	08.11.2012
		US 8035255 B2	11.10.2011
		US 8106539 B2	31.01.2012
		US 8304935 B2	06.11.2012
		US 8324759 B2	04.12.2012
WO 2010-036980 A1	01.04.2010		
WO 2010-093997 A1	19.08.2010		
WO 2012-037279 A1	22.03.2012		
US 2009-0085408 A1	02.04.2009	CA 2639155 A1	01.03.2009
		CN 101431259 A	13.05.2009

**INTERNATIONAL SEARCH REPORT**

Information on patent family members

International application No.

**PCT/US2012/060793**

Patent document cited in search report	Publication date	Patent family member(s)	Publication date
		EP 2031731 A1	04.03.2009
		JP 2009-111977 A	21.05.2009
		KR 10-2009-0023540 A	05.03.2009
		US 7999414 B2	16.08.2011
US 2011-0248573 A1	13.10.2011	EP 2428970 A1	14.03.2012
		WO 2011-125328 A1	13.10.2011
KR 10-2008-0007635 A	22.01.2008	EP 1875621 A2	09.01.2008
		US 2006-0246848 A1	02.11.2006
		US 2009-0289735 A1	26.11.2009
		US 7376407 B2	20.05.2008
		US 7792512 B2	07.09.2010
		WO 2006-115869 A2	02.11.2006
		WO 2006-115869 A3	02.11.2006
US 2008-0036588 A1	14.02.2008	US 7671736 B2	02.03.2010
		WO 2007-150070 A2	27.12.2007
		WO 2007-150070 A3	27.12.2007
		WO 2007-150070 A3	24.04.2008