

E. SCHNEIDER.  
ENDLESS TRACK FOR TRAIL GUN CARRIAGES.  
APPLICATION FILED FEB. 28, 1919.

1,326,103.

Patented Dec. 23, 1919.  
7 SHEETS—SHEET 1.

Fig. 1.

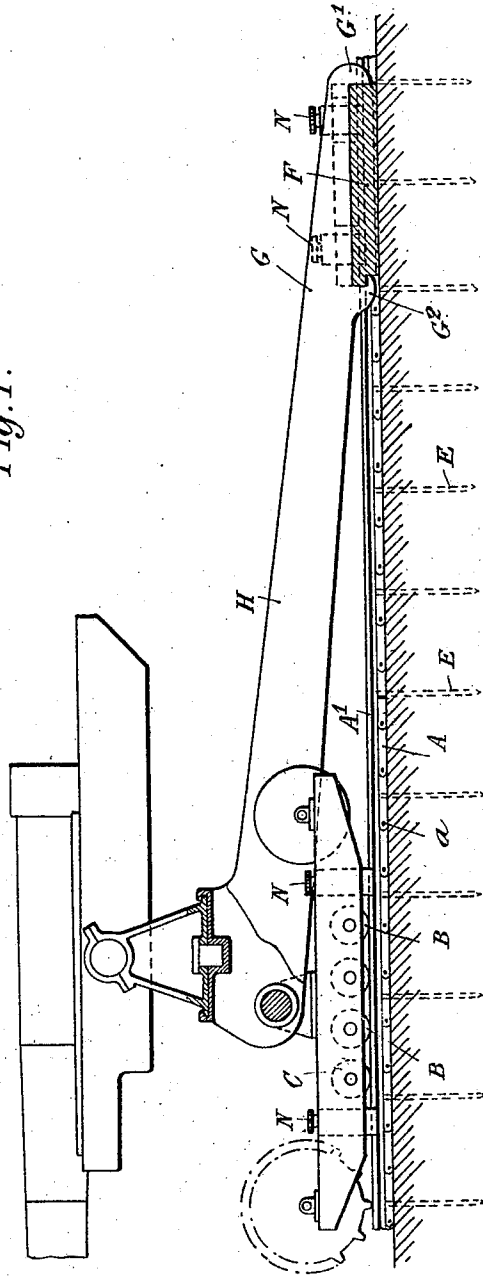

Inventor:  
Eugene Schneider  
By Messrs. Cameron, Lewis & Massie  
Attorneys.

E. SCHNEIDER.  
ENDLESS TRACK FOR TRAIL GUN CARRIAGES.  
APPLICATION FILED FEB. 28, 1919.

1,326,103.

Patented Dec. 23, 1919.

7 SHEETS—SHEET 2.

Fig. 2.

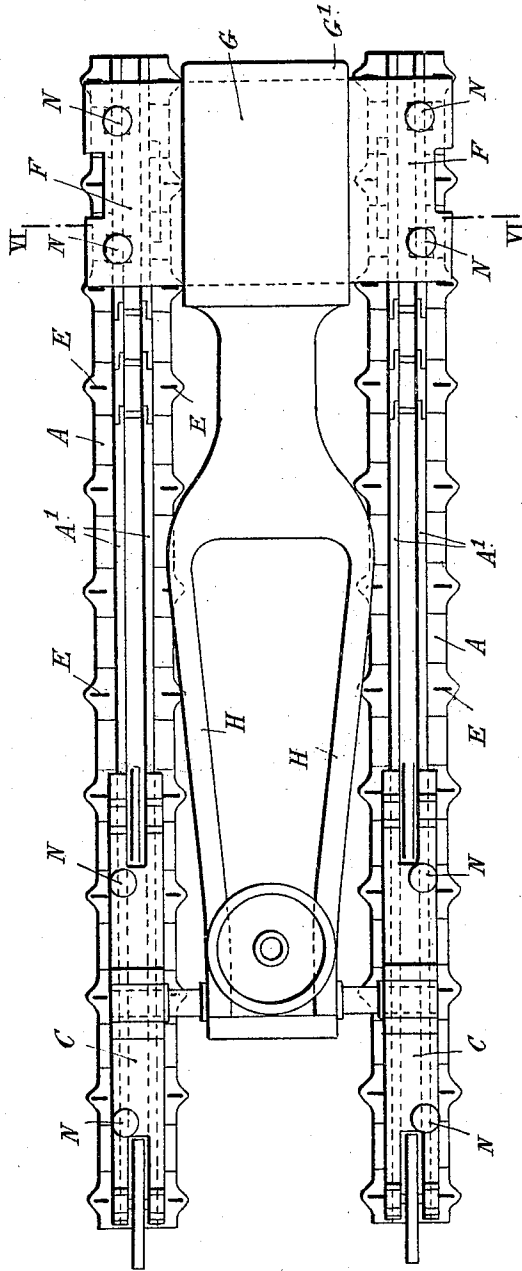

Inventor:  
Eugene Schneider,  
By Maurer, Cameron, Lewis & Mason  
Attorneys

E. SCHNEIDER.  
ENDLESS TRACK FOR TRAIL GUN CARRIAGES.  
APPLICATION FILED FEB. 28, 1919.

1,326,103.

Patented Dec. 23, 1919.  
7 SHEETS—SHEET 3.

*Fig. 4.*

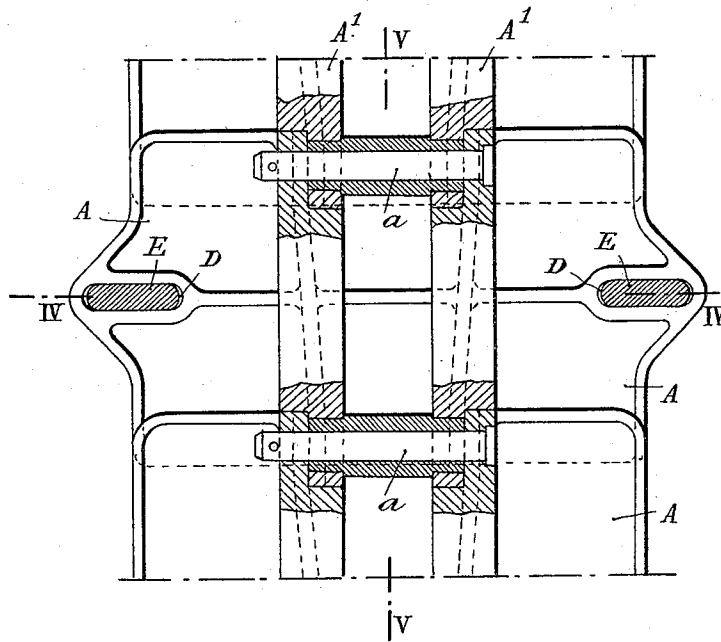
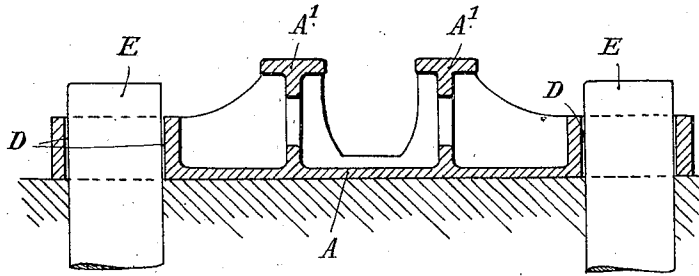

*Fig. 3.*

Inventor:  
Eugene Schneider  
By *Maurice Cameron Lewis*  
+ *Massie*,  
Attorneys

E. SCHNEIDER.  
ENDLESS TRACK FOR TRAIL GUN CARRIAGES.  
APPLICATION FILED FEB. 28, 1919.

1,326,103.

Patented Dec. 23, 1919.  
7 SHEETS—SHEET 4.

*Fig. 5.*

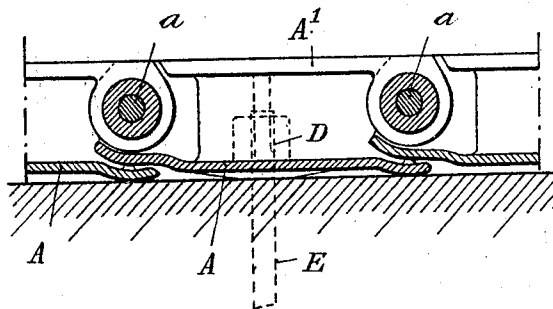

*Fig. 7.*

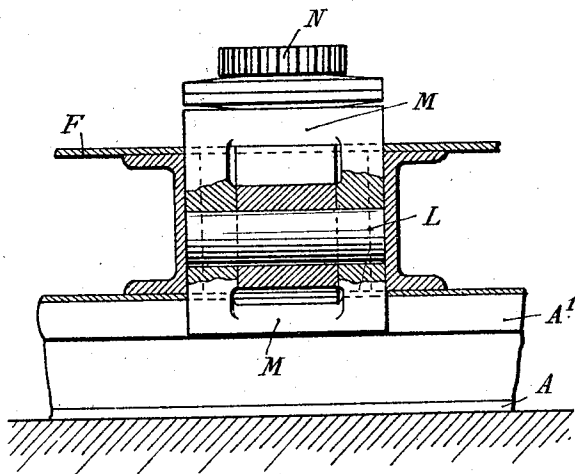

Inventor:  
Eugene Schneider,  
By Maus, Cameron, Lewis & Morris  
Attorneys

E. SCHNEIDER.  
ENDLESS TRACK FOR TRAIL GUN CARRIAGES.  
APPLICATION FILED FEB. 28, 1919.

1,326,103.

Patented Dec. 23, 1919.  
7 SHEETS—SHEET 5.

Fig. 6.

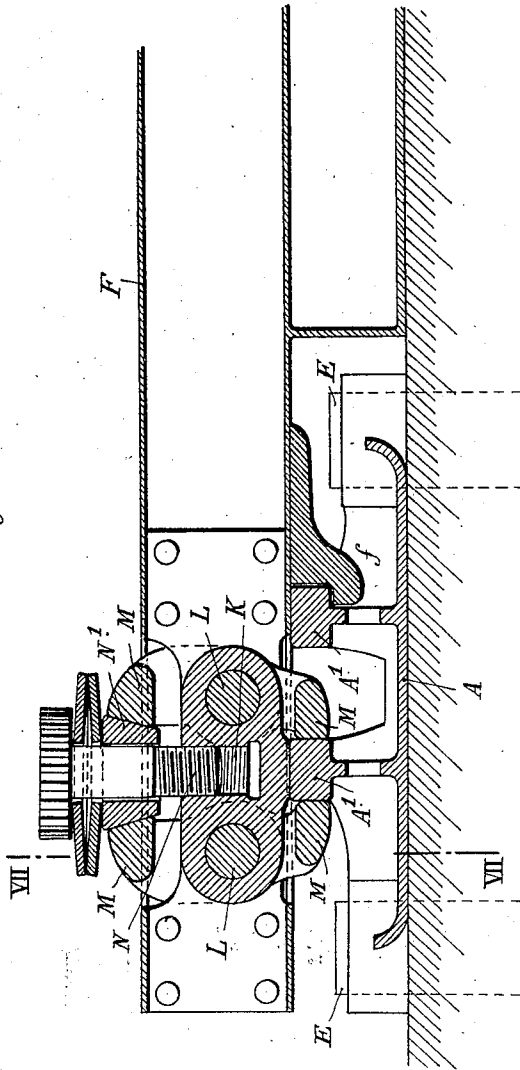

Inventor:-  
Eugene Schneider  
By Mann, Cameron, Lewis & Massey,  
Attorneys

E. SCHNEIDER.  
ENDLESS TRACK FOR TRAIL GUN CARRIAGES.  
APPLICATION FILED FEB. 28, 1919.

1,326,103.

Patented Dec. 23, 1919.  
7 SHEETS—SHEET 6.

Fig. 8.

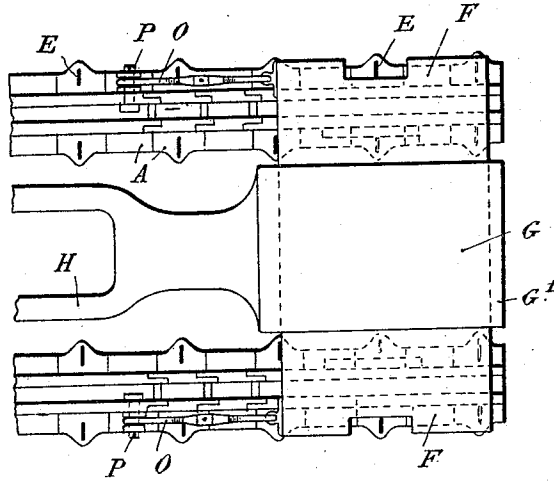
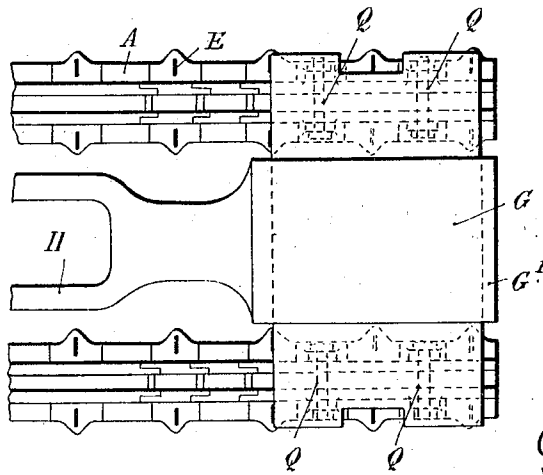

Fig. 9.



Inventor:  
Eugene Schneider,  
By Mans, Cameron & Leisner,  
Attorneys.

E. SCHNEIDER.  
 ENDLESS TRACK FOR TRAIL GUN CARRIAGES.  
 APPLICATION FILED FEB. 28, 1919.

1,326,103.

Patented Dec. 23, 1919.  
 7 SHEETS—SHEET 7.

Fig. 12.

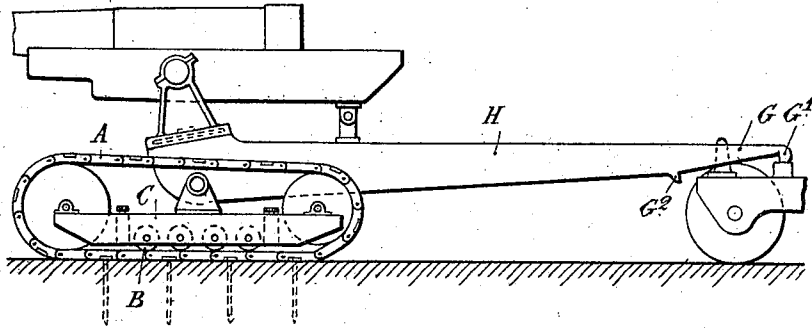

Fig. 10

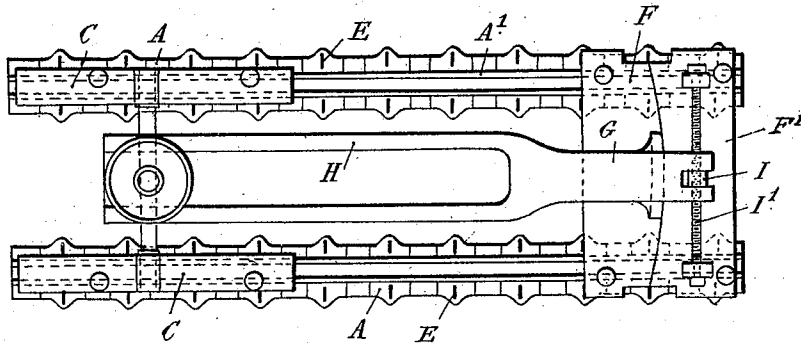
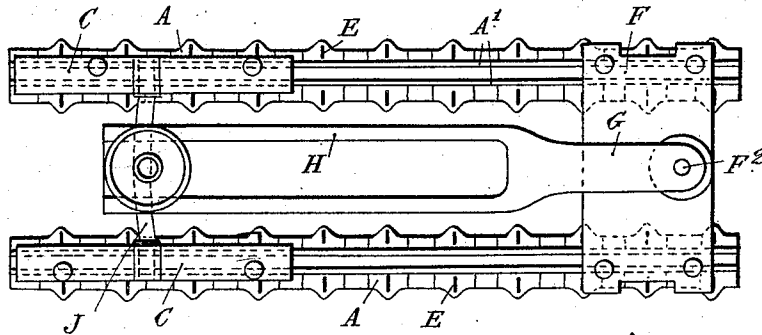

Fig. 11.



Inventor:-  
 Eugene Schneider,  
 By Mans, Cameron, Lewis & Massey  
 Attorneys.

# UNITED STATES PATENT OFFICE.

EUGÈNE SCHNEIDER, OF PARIS FRANCE, ASSIGNOR TO SCHNEIDER & CIE., OF  
PARIS, FRANCE, A LIMITED JOINT-STOCK COMPANY OF FRANCE.

## ENDLESS TRACK FOR TRAIL GUN-CARRIAGES.

1,326,103.

Specification of Letters Patent.

Patented Dec. 23, 1919.

Application filed February 23, 1919. Serial No. 279,875.

*To all whom it may concern:*

Be it known that I, EUGÈNE SCHNEIDER, a citizen of the French Republic, and a resident of 42 Rue d'Anjou, Paris, France, have  
5 invented a new and useful Improvement in Endless Tracks for Trail Gun-Carriages, which invention is fully set forth in the following specification.

This invention has for its object to provide  
10 an improved construction of endless tracks for trail gun carriages. These improved endless tracks are characterized by the feature that the treads or links of the track chains comprise guides forming slides  
15 for the passage and holding of anchoring spades. When the chains are opened out flat on the ground it is possible with such endless tracks, to constitute a real platform for firing, the gun carriage remaining normally in relation to the endless tracks, in the  
20 position it occupies during transport.

For constituting a platform by means of these improved endless tracks, this invention comprises the combination of the said endless tracks with a removable soleplate adapted to engage the end treads and serving as a support for the carriage trail. This removable soleplate that forms the rear support  
30 for the gun carriage, may also be provided with an arc-shaped guide and with mechanism for shifting the trail along the said guide. According to a modification the removable soleplate may be provided with a pivot pin and be combined in this arrangement  
35 with a curved axle serving for staying together the endless track trucks that constitute the front supports of the gun carriage on the opened-out endless tracks.

According to this invention the track  
40 trucks and the removable soleplate may be provided with suitable devices for fixing them upon the opened-out chains. Various constructional examples of this invention are illustrated in the accompanying drawings in which:

Figure 1 is a side elevation of a gun carriage of any desired construction, supported, for firing, on the opened-out endless track chains that are anchored to the ground.

50 Fig. 2 is a plan thereof.

Fig. 3 is a partial plan drawn to a larger scale of an opened-out endless track anchored to the ground.

55 Figs. 4 and 5 are sections respectively on the lines IV—IV and V—V of Fig. 3.

Fig. 6 is a vertical section drawn to a larger scale, on the line VI—VI of Fig. 2, illustrating a device for fixing the removable soleplate on the end treads of the  
60 opened-out endless tracks.

Fig. 7 is a section on the line VII—VII of Fig. 6.

Fig. 8 is a plan of a modification of the device for fixing the soleplate on the opened-out endless tracks.  
65

Fig. 9 is a plan of a second modification.

Fig. 10 is a plan of a construction in which the soleplate serves as a guide for the movements of the trail around a front pivot pin, for the purpose of training the gun.  
70

Fig. 11 illustrates diagrammatically another constructional form of the soleplate.

Fig. 12 is a diagrammatic side elevation illustrating the improved endless tracks and the gun carriage to which they are applied,  
75 in the position for transport.

Each of the endless tracks comprises in the usual manner an endless chain composed of a series of treads A jointed together by pins *a* and formed with internally projecting  
80 ribs  $A^1$  that serve as a track for the rollers B of the trucks C.

The constructional details of these known chains may be varied at will. The characteristic feature of the improved construction  
85 of chains consists in this that the treads A comprise guides D which when the chains have been opened out flat upon the ground, will form slides for guiding and holding stakes E or other similar anchoring devices.  
90

The guides or slides D are preferably formed as shown in Figs. 2, 3 and 4, by lateral lugs which are arranged along the longitudinal axis of each tread, or of only some  
95 of the treads, and are formed in one piece with the said treads. In each of the lateral lugs and the adjacent body of the slide is a slot to engage an anchoring spade driven therethrough.

By means of chains constructed in this  
100 manner it is possible to constitute for the entire gun carriage, a continuous firing platform such as the one shown in Figs. 1 and 2. In order to provide a rear support for the trail it is sufficient to attach to, the opened-out  
105 chains, a soleplate F which may for instance be engaged on the inner ribs  $A^1$  of the end treads by means of hooks *f*. Both this removable soleplate and the carriage trail G intended to rest upon it, may be variously  
110



constructed. For instance as in the example shown in Figs. 1 and 2, the trail G is provided with hooks G<sup>1</sup> and G<sup>2</sup> for its engagement with the soleplate F.

5 In the example illustrated diagrammatically in Fig. 10, the trail H of the gun carriage is assumed to be designed in such a manner as to be capable of pivoting on a platform serving as a stay for the two endless track trucks C. In this arrangement the soleplate F may comprise an arc-shaped guide F<sup>1</sup> having its center in the axis of pivotation of the head of the gun carriage. The soleplate may comprise any suitable  
10 known device I—I<sup>1</sup> for effecting the displacement of the trail G. As the screw I<sup>1</sup> is tangential to the arc of movement of the trail H, the extremity of the latter is recessed horizontally to accommodate the relative movement of the screw and trail as the latter is turned on its pivot.

In the example which is diagrammatically illustrated in Fig. 11, the removable soleplate F comprises a pivot pin F<sup>2</sup>. It is then combined with a trail head adapted to slide along a curved axle J that connects the two endless track trucks C.

For the purpose of firmly connecting together the supports of the gun carriage to the platform constituted by the endless tracks when opened-out flat and anchored to the ground, the trucks C and the soleplate F are provided with devices for attaching them to the treads A. For instance, clamping devices may be employed, such as those shown in detail in Figs. 6 and 7. These devices consist of clamping tongs. Nuts K formed respectively on the soleplate F and on the trucks C serve as supports to hinge  
30 pins L of the jaws M. A screw N provided with a wedge N<sup>1</sup> and adapted to work in the nut K, allows of clamping or unclamping at will the jaws M on to or from the guide ribs A<sup>1</sup>.

45 In the example shown in plan in Fig. 8, the soleplate F is attached by means of turnbuckles O to pins P provided in a lodgment of one of the chain treads. As shown in Fig. 9, the soleplate F may also be fixed to the end treads of the opened-out chains by means of ordinary bolts Q pressing the lugs of the soleplate upon corresponding lugs of the ribs of the treads.

Although the improved endless tracks are more particularly designed for use in constituting a firing platform, they may also serve for anchoring the chains when the latter are kept coiled in the position for transport. In such a case the endless track trucks would of course be fixed upon the chain treads by means of devices such as those shown in Figs. 6 and 7, or any other suitable devices.

Instead of arranging the guides or slides D for the passage and holding of the stakes

or other anchoring devices so as to project laterally on the treads A, they may be arranged at any other points of said treads.

What I claim is:

1. In a gun-mounting, a carriage including a truck having supporting wheels, in combination with a flexible track comprising pivoted links with each link formed of a slide to bear on the ground and a track-section on the slide to form a tread for the truck-wheels, said slide having a slot to receive an anchoring spade driven there-through.

2. In a gun-mounting, a carriage including a truck having supporting wheels, in combination with a flexible track comprising pivoted links with each link formed of a slide to bear on the ground and a track-section on the slide to form a tread for the truck-wheels, said slide having a slot to receive an anchoring spade driven there-through, and clamping means for clamping together the truck and the endless track.

3. In a gun-mounting, a carriage including a truck having supporting wheels, in combination with a flexible track comprising pivoted links with each link formed of a slide to bear on the ground and a track-section on the slide to form a tread for the truck-wheels, said slide having a slot to receive an anchoring spade driven there-through, a trail having its head pivoted on the carriage, and a sole-plate carrying the tail of the trail and mounted on the flexible track.

4. In a gun-mounting, a carriage including a truck having supporting wheels, in combination with a flexible track comprising pivoted links with each link formed of a slide to bear on the ground and a track-section on the slide to form a tread for the truck-wheels, said slide having a slot to receive an anchoring spade driven there-through, a trail having its head pivoted on the carriage, a sole-plate carrying the tail of the trail and mounted on the flexible track, and means for clamping the sole-plate to the flexible track.

5. In a gun-mounting, a carriage including a truck having supporting wheels, in combination with a flexible track comprising pivoted links with each link formed of a slide to bear on the ground and a track-section on the slide to form a tread for the truck-wheels, said slide having a slot to receive an anchoring spade driven there-through, a sole-plate mounted on the flexible track, and a trail having its head supported by the carriage and its tail by the sole-plate, said trail being pivoted to one of its supports and having angular displacement on its other support.

6. In a gun-mounting, a carriage including a truck having supporting wheels, in combination with a flexible track comprising

ing pivoted links with each link formed of a slide to bear on the ground and a track-section on the slide to form a tread for the truck-wheels, said slide having a slot to receive an anchoring spade driven there-  
 5 through, a trail having its head pivotally mounted on the carriage, and a sole-plate adjustably mounted on the flexible track and having an arc-shaped bearing for the  
 10 tail of the trail.

7. In a gun-mounting, a carriage including a truck having supporting wheels, in combination with a flexible track to form a tread for the truck-wheels, means for an-  
 15 choring the track to the ground in an extended position, a trail having its head pivoted on the carriage, and a sole-plate carrying the tail of the trail and mounted on the flexible track.

8. In a gun-mounting, a carriage including a truck having supporting wheels, in combination with a flexible track to form a tread for the truck-wheels, means for an-  
 20 choring the track to the ground in an extended position, a trail having its head pivoted on the carriage, a sole-plate carrying the tail of the trail and mounted on the flexible track, and means for clamping the soleplate to the flexible track.

9. In a gun-mounting, a carriage including a truck having supporting wheels, in combination with a flexible track to form a

tread for the truck-wheels, means for an-  
 35 choring the track to the ground in an extended position, a sole-plate mounted on the flexible track, and a trail having its head supported by the carriage and its tail by the sole-plate, said trail being pivoted to one of its supports and having angular displacement on its other support.

10. In a gun-mounting, a carriage including a truck having supporting wheels, in combination with a flexible track to form a tread for the truck-wheels, means for an-  
 40 choring the track to the ground in an extended position, a trail having its head pivotally mounted on the carriage, and a sole-plate adjustably mounted on the flexible track and having an arc-shaped bearing for the tail of the trail.

11. In a gun-mounting, a flexible track comprising pivoted links with each link formed of a slide to bear on the ground and provided with a slot to receive an anchoring  
 55 spade driven therethrough.

12. In a gun-mounting, a flexible track comprising pivoted links with each link formed of a slide and a track-section on the slide, said slide having a slot to receive an  
 60 anchoring spade driven therethrough.

In testimony whereof I have signed this specification.

EUGÈNE SCHNEIDER.