

W. C. LEACH & M. J. KNOX.

Lock.

No. 36,221.

Patented Aug. 19, 1862.

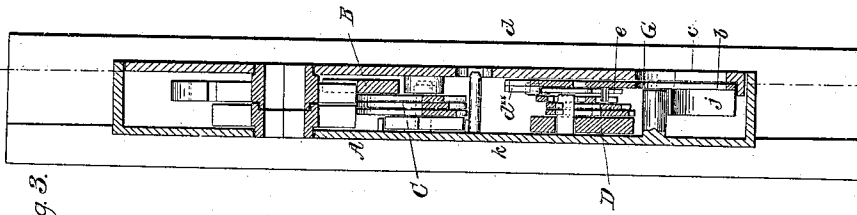

Fig. 3.

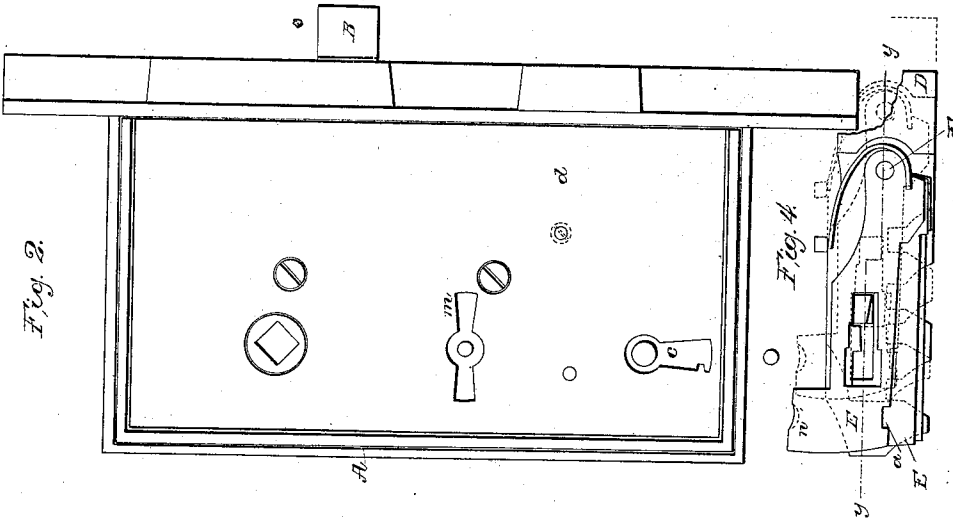

Fig. 2.

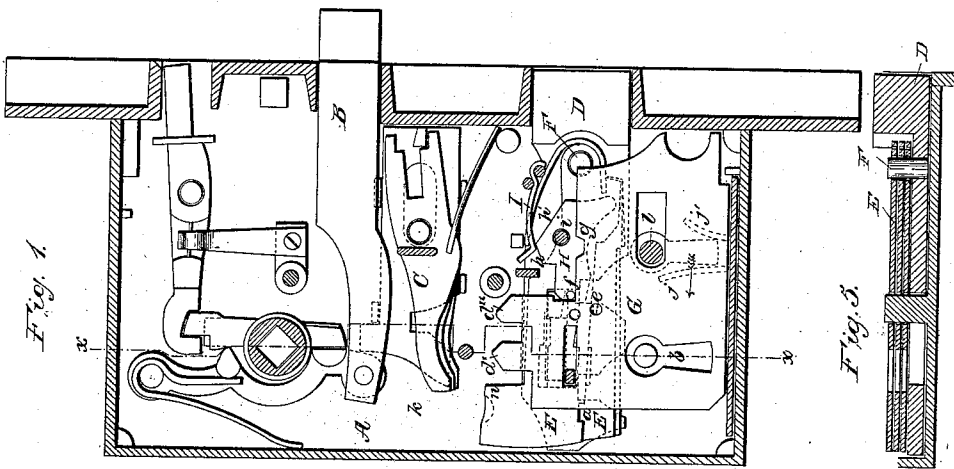

Fig. 1.

Fig. 5.

Witnesses.
J. W. Brown.
James David.

Inventors.
W. C. Leach
M. J. Knox
per Munst Co.
Attorneys.

UNITED STATES PATENT OFFICE.

WILLIAM C. LEACH AND M. J. KNOX, OF KNOX CORNERS, NEW YORK.

IMPROVEMENT IN LOCKS.

Specification forming part of Letters Patent No. 36,221, dated August 19, 1862.

To all whom it may concern:

Be it known that we, WILLIAM C. LEACH and M. J. KNOX, of Knox Corners, in the county of Oneida and State of New York, have invented a new and useful Improvement in Locks; and we do hereby declare that the following is a full, clear, and exact description of the same, reference being had to the accompanying drawings, making a part of this specification, in which—

Figure 1 is a side view of our invention, the plate of the lock-case nearest the eye being removed in order to show the interior. Fig. 2 is a side view of the same. Fig. 3 is a section of the same, taken in the line *x x*, Fig. 1. Fig. 4 is a detached side view of the main bolt-tumblers and bolt. Fig. 5 is a longitudinal section of Fig. 4, taken in the line *y y*.

Similar letters of reference indicate corresponding parts in the several figures.

This invention relates to an improved slide or guard for the key-hole of the lock, whereby the outer key-hole, when the lock is locked, will be effectually guarded, so that the lock cannot be picked or illegitimately unlocked.

To enable those skilled in the art to fully understand and construct our invention, we will proceed to describe it.

A represents the lock-case, which may be constructed in the usual way, and B is the night latch or slide, provided with tumblers C, arranged as usual and operated by a separate or independent key.

D represents the main bolt of the lock, the inner portion of it being reduced in thickness so as to accommodate a series of three tumblers, E, which lie upon it and are confined thereto at one end by the pin F on said bolt. The peculiarity connected with these tumblers consists in a notch, *a*, which is made in the lower edge of the tumbler adjoining the outer side of the case. (See Figs. 1 and 4.)

G is a slide, which is secured to the inner side of the plate *d*. This slide has a hole or opening, *b*, made through it which corresponds in shape to the shape of the key-hole *c* in the outer side, *d*, of the lock-case, and when said slide is adjusted so that the hole *b* coincides with the hole *c* the key may be inserted in the lock at the outer side of the door. When the slide is adjusted so that the holes *b* and *c* are out of line with each other, the hole *c* is closed.

This will be fully understood by referring to Fig. 1, in which the lock is shown in an unlocked state and the hole *b* in line with *c*.

The slide G is provided with two projections, *d*^{*} *d*[×], at its upper end, as shown in Fig. 1, and a pin, *e*, projects longitudinally from the slide a short distance from its upper edge. This pin *e*, when the bolt D is shot forward and the slide G covers the outer key-hole, *c*, and the lock is in a locked state, fits into the notch *a* of the tumbler E, previously referred to, and prevents the casual movement of the slide—in fact locks it—so that it cannot be shoved back to escape the key-hole *c* without raising said tumbler.

H is a tumbler, which is secured to the inner side of the plate *d* of the lock-case directly over the slide G. This tumbler H has a pin, *f*, projecting horizontally from it, which, when the slide G is so adjusted as to cover the key-hole *c*, fits at certain times in a notch, *g*, in the upper edge of the slide G. The upper edge of the tumbler H is formed of two inclined planes, *h h'*, upon either of which a spring, I, bears, according to the position in which said tumbler may be placed.

The tumbler H is hung upon a pivot, *i*, and when it is so turned or adjusted that the spring I bears upon the inclined surface or plane *h* the pin *f* will not be forced down into the notch *g* when the latter is underneath the former; but when the tumbler H is so turned or adjusted that the spring I will bear upon the inclined surface or plane *h'* the spring will force the pin *f* into said notch *g*.

The tumbler H is acted upon by the key which actuates the main bolt D of the lock, and this key also, when the lock is locked at the inner side of the door, moves the slide G, the latter having two curved flanges, *j j'*, for the bits of said key to act upon. (See Fig. 1, in which both flanges are shown by dotted lines.)

The plate *k*, or inner plate of the lock-case A, is provided with a key-hole, *l*, which is out of line with the key-hole *c* in the plate *d* at the outer side of the lock-case, as shown clearly in Fig. 1.

The operation is as follows: Suppose the lock to be in an unlocked state and the slide G so adjusted that its hole or opening *b* is in line with the key-hole *c* in the outer side of

the lock. In locking the lock at the inner side of the door the key is inserted in the hole *l*, and its bits fit between the flanges *j j'* on the slide *G*. The operator turns the key from left to right, or in the direction indicated by the arrow *l*, and thereby turns the slide *G* in the same direction, so that its hole *b* will be out of line with the outer key-hole, *c*, and the latter consequently covered or protected by the slide. The key being still turned in the same direction, raises the tumblers *E* and liberates the main bolt *D*, so that it may be shot out from the lock-case *A* into the "strike" or nosing, and a bit on the key then comes in contact with the tumbler *H* and turns it so that the spring *I* will press on the inclined surface or plane *h'* and force the pin *f* of the tumbler into the notch *g* in the upper edge of the slide, and the notch *a* in the tumbler *E* will also catch over the pin *e* of the slide. When the door, therefore, is locked from the inner side, it cannot be unlocked from the outer side, as there is no means for throwing back the slide *G*, as it is locked by the pin *f* of tumbler *H* and its own pin *e*, over which the notch *a* of the tumbler *E* catches. In case, however, of the door being locked from the outer side, the slide is moved or adjusted by the night-key, which is, after the bolt *D* is shoved out, inserted in the hole *m* and made to act upon the projection *d^x*, so as to shove the slide back over the key-hole *c*; and in order to move the slide forward, or in a contrary direction, to expose the key-hole *c*, the bit of the night-key catches under a projection, *n*, at the upper part of the tumbler *E*, which is provided with the notch *a*, and raises said

tumbler so that the pin *e* of the slide *G* will be free from the notch *a*, and the slide allowed to move under the action of the night-key, which on being turned in a reverse direction acts against the projection *d^x* of the slide *G*.

When the door is locked from its outer side, it will be understood that the pin *e* of the slide *G* and the notch *a* of the tumbler *E* alone retain the slide in its position over the outer key-hole, *c*.

We are aware that sliding plates or key-hole guards have been used in locks and arranged to operate in various ways. We do not therefore claim, broadly, such device, irrespective of the arrangement and mode of operating the same as herein described; but,

Having thus described our invention, what we do claim as new, and desire to secure by Letters Patent, is—

1. The slide *G*, provided with the notch *g* in its upper edge, in combination with the tumbler *H*, provided with the pin *f*, all arranged so as to be operated by the key of the main bolt *D*, substantially as and for the purpose set forth.

2. The pin *e* on the slide *G*, in combination with the notch *a* in the tumbler *E*, and the projection *n* on said tumbler, arranged, as shown, so as to admit of the latter being operated either by the key of bolt *D* or the key of the night-latch, as set forth.

WM. C. LEACH.
M. J. KNOX.

Witnesses:

WM. M. FAIRCHILD,
RUSH M. HOWARD.