



**(12) PATENT ABRIDGMENT (11) Document No. AU-B-23874/88**  
**(19) AUSTRALIAN PATENT OFFICE (10) Acceptance No. 635491**

- (54) Title  
**IMPROVEMENTS IN OR RELATING TO KEYBOARD SYSTEMS**
- International Patent Classification(s)  
 (51)<sup>4</sup> **B41J 005/08 H01H 013/70**
- (21) Application No. : **23874/88** (22) Application Date : **09.09.88**
- (87) PCT Publication Number : **WO89/02369**
- (30) Priority Data
- | (31) Number   | (32) Date       | (33) Country        |
|---------------|-----------------|---------------------|
| <b>PI4363</b> | <b>15.09.87</b> | <b>AU AUSTRALIA</b> |
| <b>PI4649</b> | <b>28.09.87</b> | <b>AU AUSTRALIA</b> |
| <b>PI4898</b> | <b>15.10.87</b> | <b>AU AUSTRALIA</b> |
| <b>PI9743</b> | <b>09.08.88</b> | <b>AU AUSTRALIA</b> |
| <b>PJ0095</b> | <b>29.08.88</b> | <b>AU AUSTRALIA</b> |
- (43) Publication Date : **17.04.89**
- (44) Publication Date of Accepted Application : **25.03.93**
- (71) Applicant(s)  
**MICHAEL PHAM**
- (72) Inventor(s)  
**MICHAEL PHAM**
- (56) Prior Art Documents  
**FR 2587815**  
**GB 2189195**  
**EP 134160**
- (57) Claim

1. A keyboard system comprising right-hand keyboard means and left-hand keyboard means, each said keyboard means being adapted for operation by the digits of a respective hand of an operator, and an array of keys on each keyboard means arranged in a manner such that a said operator is able to operate all the keys of a said keyboard means without having to move the hand relative thereto; each keyboard means having, associated therewith, a respective reference panel upon which the said keyboard means is moveable to any one of a plurality of locations, each combination of keyboard means and its reference panel at different locations being related to a set of keys of each array; whereby the combination of the keys capable of being addressed by a said operator and their indicated values is able to be changed by moving the or each keyboard means from one location to another on the reference panel.



## INTERNATIONAL APPLICATION PUBLISHED UNDER THE PATENT COOPERATION TREATY (PCT)

(51) International Patent Classification<sup>4</sup> :

B41J 5/08, H01H 13/70

A1

(11) International Publication Number:

WO 89/02369

(43) International Publication Date:

23 March 1989 (23.03.89)

(21) International Application Number: PCT/AU88/00349

(22) International Filing Date: 9 September 1988 (09.09.88)

(31) Priority Application Numbers:

PI 4363  
PI 4649  
PI 4898  
PI 9743  
PJ 0095

(32) Priority Dates:

15 September 1987 (15.09.87)  
28 September 1987 (28.09.87)  
15 October 1987 (15.10.87)  
9 August 1988 (09.08.88)  
29 August 1988 (29.08.88)

(33) Priority Country:

AU

(71)(72) Applicant and Inventor: PHAM, Michael [AU/AU];  
56 Wilga Street, Fairfield, NSW 2165 (AU).

(74) Agent: WATERMARK: Suite 6, Floor 16, Town Hall House, 456 Kent Street, Sydney, NSW 2000 (AU).

(81) Designated States: AT (European patent), AU, BE (European patent), CH (European patent), DE (European patent), FR (European patent), GB (European patent), IT (European patent), JP, KP, KR, LU (European patent), NL (European patent), SE (European patent), US.

Published

With international search report.

635491

A.O.J.P. 25 MAY 1989

AUSTRALIAN

17 APR 1989

PATENT OFFICE

(54) Title: IMPROVEMENTS IN OR RELATING TO KEYBOARD SYSTEMS

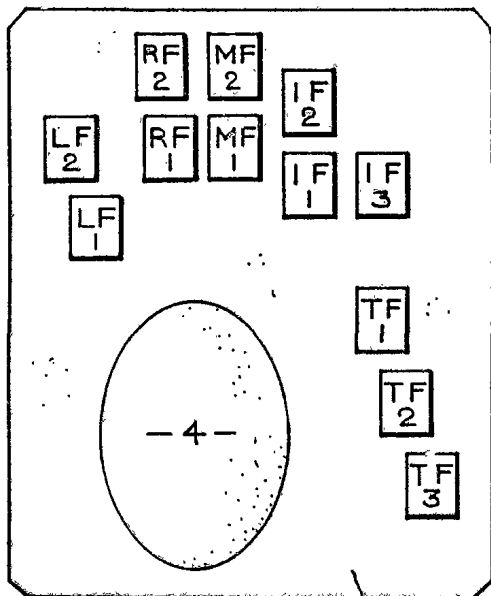

2

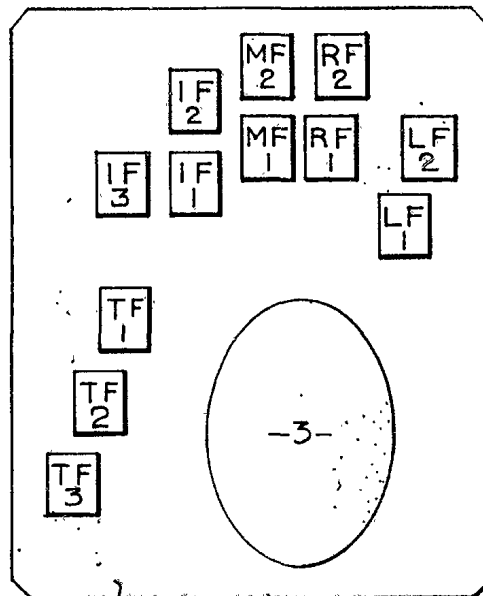

1

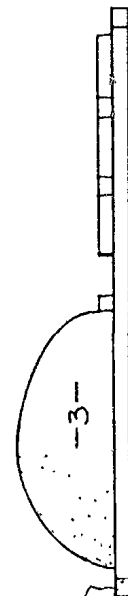

1

(57) Abstract

A keyboard system comprising separate right- and left-hand keyboard means, possibly on the one keyboard, but preferably separate right- and left-hand keyboards (1, 2; Fig. 2), each adapted for operation by the digits of a respective hand of an operator, whereby the operator is able to operate all the keys of each keyboard without having to move the hands relative thereto. In preferred form, each keyboard has associated therewith, a respective reference panel (5, 6; Fig. 1) upon which the keyboard is movable to a plurality of locations, with each combination of left- and right-hand locations being related to a set of keys, type characters or symbols, whereby the number of keys capable of being addressed by the operator is increased.

IMPROVEMENTS IN OR RELATING TO KEYBOARD SYSTEMSTECHNICAL FIELD

This invention relates to keyboard systems and more particularly to a highly versatile, dual keyboard system which enables an operator to "address" a greater number of keys than prior art systems generally permit.

BACKGROUND ART

In 1868 Christopher Latham Sholes and Carlos Glidden invented the first typewriter - a crude device with eight rows of keys but no carriage-return mechanism. A few years later the two men decided to reduce the number of key rows to four and to rearrange the keys. For reasons still unknown, they placed the letters, Q, W, E, R, T and Y in a left-to-right sequence on the top row of the keyboard. Thus was born the S & G QWERTY key layout, which later became a standard feature of the Remington typewriter - and an enduring 19th-century legacy.

Today nearly all keyboards incorporate the QWERTY layout, despite sporadic criticism that it is inefficient and contributes to hand and wrist strains among those who type or key-punch information for a living.

Present-day keyboards for such devices as computers, word-processors and the like are lineal descendants of the old typewriter and comptometer keyboards. These old keyboards comprised an array of digit-operated "keys" identified by letters, numerals, mathematical signs, punctuation marks and/or other indicia, all arranged in set patterns.

On complex present-day keyboards, an operator needs to continually glance at the keyboard while operating it and to lightly move his or her hands over it in order to select the required keys for the task in progress.

In the case of the old typewriter and comptometer keyboards, force had to be applied to the keys in order to operate the machine. This applied force was relatively small and, after initial training, the typist or

comptometrists suffered no noticeable muscular fatigue. The more recent "golf-ball" electric typewriter still did require some modicum of force but its electronic descendants do not, an operator's hands hover over the keyboard, barely touching the keys and certainly not pushing them down. The more keys the operator is required to address, the more expansive the hand movements must become. This has resulted in a "new" kind of muscular injury - the so-called "repetitive strain injury", or "RSI".

It has previously been proposed to provide a "Data Input System Using a Split Keyboard", being the subject of U.S. Patent No. 4,378,553, the specification relating to which, however, does not disclose, for example, different "gate positions" providing different key combinations available to each of an operator's hands and/or different combinations of indicia and/or type-faces.

Other examples of relevant background art are the Australian Patent Application Nos. 60995/86; 44323/85 (PCT/EP85/00263); 42628/85; 72949/81; 27580/77 (506074); 19223/76 (502377); 7973/46 and 49711/85. British Patent Application No. GB 2135633A corresponds to U.S. Patent No. 4,378,553.

#### DISCLOSURE OF INVENTION

It is therefore an object of the present invention to overcome the above and other disadvantages by the provision of a micro-processor-based keyboard system having separate left- and right-hand keyboard means, possibly on the one keyboard, but preferably comprising separate right-hand and left-hand keyboards, each movable on a respective reference panel in combination with audio/visual display or indication means and, optionally, a plurality of pedal keys and/or cyclic counters and/or mode registers and/or code register.

Thus, in accordance with the present invention, a keyboard system comprises a right-hand keyboard means and a left-hand keyboard means - preferably as separate left and

right keyboards - each adapted for operation by the digits of a respective hand of an operator, and an array of keys on each keyboard arranged in such a manner that the operator is able to operate all the keys of the keyboard without having to move his or her hand relative to the said keyboard. Each key may represent a plurality of different characters or symbols, depending on the particular mode or process and/or different keyboard or "gate" position or location.

Preferably, each keyboard has, associated with it, a respective reference panel upon which the keyboard is movable to a plurality of locations, each combination of these locations being related to a set of keys of each array of the same, so that the number of keys which are capable of being addressed by the operator is able to be increased.

Ideally, each of the keyboards may well be provided with a palm-rest upon which the operator is able to rest, or relax, his or her hand, this palm-rest thus constituting a reference point for the operator to find the required keys, the palm-rest furthermore being operable to move its associated keyboard from one position to another on the respective reference panel.

#### BRIEF DESCRIPTION OF DRAWINGS

In order that the reader may gain a better understanding of the present invention, hereinafter will be described one or more embodiments thereof, by way of example only and with reference to the accompanying schematic drawings in which:-

Figure 1 shows the generalized layout of a keyboard system according to the present invention;

Figure 2 shows a pair of keyboards; and

Figure 3 illustrates means for adjusting the distance between a palm-rest and an associated keyboard.

#### BEST MODE FOR CARRYING OUT THE INVENTION

Turning firstly to Figure 2, it will be seen that in the preferred mode employing separate keyboards, a right-hand keyboard 1 and a left-hand keyboard 2 are

mirror-images one of the other. Each of the keyboards 1, 2 has twelve keys, arranged as shown, and a palm-rest - these being respectively referenced 3 and 4. Thus, the operator is able to rest his or her hands upon the palm-rests 3, 4 and to use all ten digits to operate any key of the arrays of twenty four without having to move the hands relative to the pair of keyboards 1, 2. As will be appreciated, these palm-rests are conducive to the operator's resting, or relaxing, the hands, in contrast to conventional keyboards where the operator is actively encouraged to maintain his or her hands in a raised stance above, or at least relative to, the keyboard. This, needless to say, can be tiresome or inducive of fatigue after prolonged periods of operation.

On each keyboard, two keys designated IF3 and TF3 are held in reserve for special functions. Therefore, the operator should only address a total of twenty keys. However, in order to increase the number of keys able to be addressed, the operator can use any one, or any combination of, five processes, as will be made clear hereinafter.

Referring now to Figure 1 of the drawings, each keyboard 1, 2 is associated with a respective reference panel 5, 6 provided on such as a conventional console or the like.

By moving keyboard 1 about a gate 7, and, independently, keyboard 2 about an identical gate 8, each of the keyboards 1, 2 will be able to be located in any of the six numbered positions, or locations, of each gate.

Thus, as the operator is able to address ten keys with the digits of his or her hands, (-the two special function keys IF3 and TF3 not to be counted -) and since each keyboard can be located in any one of the six reference panel gate positions, then the operator is able to address a total of  $6 \times 6 \times 20 = 720$  keys without even having to remove the two hands from the keyboards. The actual key characters accessed, or available to be accessed, by means of the keys in any gate position are displayed as shown at 22 on the

visual display panel 15.

The abovenoted process is to be considered to constitute "Process 1".

"Process 2" involves the use of foot-operated pedal keys, there being provided three right-foot pedal keys, referenced 9, and three corresponding left-foot pedal keys, referenced 10. Again operating the twenty digit keys on keyboards 1 and 2 in conjunction with the pedal keys trios 9 and 10, the operator is able to address a total of  $3 \times 3 \times 20 = 180$  keys.

"Process 3" involves the use of one of the two special function counter keys, namely the IF3 keys on the keyboards (Fig. 2). Each IF3 key is used to operate a respective cyclic counter, and each cyclic counter has three values, referenced 11 and 12 in Figure 1. Every time the operator presses one of the IF3 keys, its corresponding counter will count one step starting from 1, then 2 and 3, and then back to 1. Each combination of the counters' values corresponds to a set of 20 keys. Therefore, now the operator is again able to address a total of  $3 \times 3 \times 20 = 180$  keys.

"Process 4" involves the use of combinations of two keys of each of the keyboards (Fig. 2) in order to address still more keys. The following key combinations are used for each keyboard:-

TF3 and IF1; TF3 and MF1; and TF3 and RF1 (Fig. 2). Pressing any of these pairs of keys will generate an "interrupt" to the microprocessor, which will note this and set a corresponding value on a "mode" register. Each keyboard has a mode register key and each mode register has three values, referenced 13 and 14 (Fig. 1). Each pair of mode register value corresponds to a set of 20 keys of the arrays of such; thus, using this process, the operator can address a total of  $3 \times 3 \times 20 = 180$  keys.

"Process 5" involves the use of a voice recognition system. The operator can change the set of 20

keys to be addressed by reading a special code to a microphone. The microprocessor analyses the code, updates a "code" register accordingly and displays the value of the "code" register on the Display Panel (see reference 23, Fig. 1). A set of 20 keys is assigned to each value of the "code" register. In this embodiment of the invention, there are three values of the "code" register. Therefore, using this process the operator can address a total of  $3 \times 20 = 60$  keys.

As will be appreciated, by combining the five processes 1, 2, 3, 4 and 5 as described above, the keyboard system according to the present invention will allow an operator to address keys to a grand total of  $720 \times 180 \times 180 \times 180 \times 60$ , that is  $2.519424 \times 10^{11}$  keys altogether.

Moreover, it will be seen to be theoretically possible to enlarge the already large capacity of the inventive keyboard system to address more than this  $2.519424 \times 10^{11}$  keys by increasing any or all of the following parameters:- numbers of keys; number of "gate" reference panel positions; cyclic counter values; and mode registers' values. On the other hand, by reducing the number of variables, a simpler and perhaps more economical system can be postulated.

The keyboard system according to the present invention may further include a separate visual display panel, referenced 15, or the data may be displayed in the VDU monitor itself by virtue of a split-screen arrangement as is known in the art. Alternatively, or even additionally, to the visual display there can be operative links to suitable audio indicators each having a distinctive sound, whereby the operator can identify a particular key position with a characteristic sound. This feature makes the inventive keyboard system an ideal means for enabling blind persons to be able to type, based on simple audio-identification of the various keyboard positions, without the need to see either the keyboard, the display



screen, or the VDU terminal screen.

The display panel has several functions:-

(a) to indicate to the operator that set of twenty keys that can be accessed by the operator for any gate/pedal position, or any counter/mode/code register values;

(b) to indicate to the operator which key is presently being pressed;

(c) to indicate to the operator the relative positions of the keyboards with respect to the reference gate panels (process 1);

(d) to indicate to the operator which pedal key is presently being pressed (process 2);

(e) to indicate to the operator the current values of the cyclic counters (process 3);

(f) to indicate to the operator the current values of the "mode" registers (process 4);

(g) to indicate to the operator the current value of the "code" register (process 5); and

(h) to eliminate the need for the operator to look at the keyboards in order to find the position of a wanted key, thereby enabling the operator to position the dual keyboards at any selected position.

As has been previously stated, the operator is able to operate all keys without having to move his or her hands from the keyboard; the combination of the relative positions of the keyboard with respect to the reference panels and/or the state of pedals, the counters, "mode" and "code" registers' values are used to address difference sets of keys.

Because the operator has no need to move his or her hands about the keyboard, unlike the case of conventional keyboard, he or she is enabled to address keys with greater rapidity.

Furthermore, as the operator no longer needs to look at his or her hands, it is possible for the keyboards

to be located at a position - perhaps further from the operator's eyes at which "typing" efficiency is much improved. A hand-position can be selected to maintain correct blood circulation in the operator's hands, thus preventing, or at least ameliorating, RSI and like conditions.

In a further embodiment of the invention, by the provision of suitable additional hardware or software as may be appropriate, some or all of the keys may be programmable by the operator. This feature will enable the operator to assign any required or standard symbol to any particular key. In this way it will be possible to override the original keyboard configuration provided by the manufacturer. The advantage of this facility is that it enables the operator to "tailor" the keys according to the personal needs of the operator. This facility should result in increased efficiency and productivity for any particular operator.

A further advantage of this facility is that it enables the introduction of any new symbols or characters, to be assigned to any one or more keys. This feature has potential applications, for example, to:-

- drawing packages
- word processing
- adaption for use in stenography
- adaption for use with various languages and for non-Roman alphabets, e.g., Arabic, Cyrillic, Armenian, Greek, Hebrew, Chinese, Japanese, Korean, etc.
- adapting for use with keyboards operated electronic musical instrument.

There would also be a special reset provision to enable the operator to record a number of new configurations and to change from one keyboard configuration to the next. The keyboard configurations number X is displayed in the display panel as KBCNo X referenced 16. The operator can

record a new configuration or modify an existing one by communicating his or her request with a suitable host computer. This will enable the keyboard system to be very versatile and can be multi-functional.

Turning finally to Figure 3, there is shown a vertical cross-section through a palm-rest 3, 4; an associated keyboard 1, 2; and a typical key 17. Palm-rest 3, 4 is fitted onto a shaft 18 to permit of vertical adjustment with respect to keyboard 1, 2. The palm-rest is able to be clamped to its shaft by means of a grub- or set-screw 19. In similar manner, the key 17 is fitted onto a spindle 20 and is clampable thereto by means of a grub- or set-screw 21. As this arrangement allows the operator to move the palm-rest and keys independently upwardly and downwardly on their respective shafts or spindles, the distance between palm-rest and keys is able to be varied to thus accommodate different hand sizes.

In the case of the keys, the location of each grub- or set-screw may be dictated by the distance of any key from adjacent keys; instead of the more usual screwdriver slot in the head of the screw, an allen-key recess is preferable.

#### INDUSTRIAL APPLICABILITY

The present invention has application to computers, typewriters, word-processors, printers, defence equipment, and keyboard-operated electronic musical instruments such as sound synthesizers.

From the abovegoing, it will be readily appreciated by those skilled in the art that numerous variations and modifications may be made to the invention without departing from the spirit and scope thereof as set out in the following claims.

RECEIVED 17 NOV 1989

CLAIMS

1. A keyboard system comprising right-hand keyboard means and left-hand keyboard means, each said keyboard means being adapted for operation by the digits of a respective hand of an operator, and an array of keys on each keyboard means arranged in a manner such that a said operator is able to operate all the keys of a said keyboard means without having to move the hand relative thereto; each keyboard means having, associated therewith, a respective reference panel upon which the said keyboard means is moveable to any one of a plurality of locations, each combination of keyboard means and its reference panel at different locations being related to a set of keys of each array; whereby the combination of the keys capable of being addressed by a said operator and their indicated values is able to be changed by moving the or each keyboard means from one location to another on the reference panel.

2. The keyboard system as claimed in Claim 1, wherein said right-hand keyboard means and said left-hand keyboard means comprise separate keyboards.

3. The keyboard system as claimed in Claim 1 or Claim 2, wherein each keyboard means is provided with a palm-rest constituting a reference point for a said operator to find the required keys and providing means whereon said operator is able to rest the hand; each said palm-rest including means to move its associated keyboard means from one position to another on the respective reference panel.

4. The keyboard system as claimed in Claim 3, wherein mechanical means are provided to move each said palm-rest and each said key array independently of one another to thereby enable the distance therebetween to be varied to accommodate different hand sizes.

5. The keyboard system as claimed in any one of the



SUBSTITUTE SHEET

preceding claims, wherein there is provided a plurality of pedal keys each operable by pressure of a said operator's foot, each combination of the said pedal keys being related to a set of keys of each array; whereby the combination of the keys capable of being addressed by a said operator is able to be changed.

6. The keyboard system as claimed in any one of the preceding claims, wherein there are provided two or more counter keys each adapted to operate a respective cyclic counter, each combination of counts or displayed values of the said cyclic counters being related to a set of keys of each array, whereby the combination of the keys capable of being addressed by a said operator is able to be changed.

7. The keyboard system as claimed in any one of the preceding claims, wherein there are provided one or more mode register means each having two or more registrable counts or values, each combination of said counts or values being related to a set of keys of each array, whereby the combination of the keys capable of being addressed by a said operator is able to be changed.

8. The keyboard system as claimed in any one of the preceding claims, wherein there is provided at least one audible signal register means, the or each having two or more duplicatable audible signals or values, each combination of said signals or values being related to a set of keys of each array, whereby the combination of the keys capable of being addressed by a said operator is able to be changed.

9. The keyboard system as claimed in any one of the preceding claims, further including a display unit adapted to provide audio/visual feedback information to a said operator to enable the operator to correlate manipulative



SUBSTITUTE SHEET

movements without having to look at said keys, to indicate the set of keys that can be addressed and optionally to indicate keys being pressed and the indicia or symbols thereof.

10. The keyboard system as claimed in Claim 9, wherein said display unit is a discrete unit at a location physically separated, or remote, from the keys of said keyboard means.

11. The keyboard system as claimed in any one of the preceding claims, further including hardware and/or software adapted to enable the introduction of new symbols and/or characters assignable to any one or more said keys so as to override the original keyboard configuration, the resulting new keyboard configuration being able to be identified, modified and/or recorded.

12. The keyboard system as claimed in any one or the preceding claims, further including a voice recognition system adapted to change a set of keys being addressed by a said operator to thus enable the combination of keys being addressed by a said operator to be changed.

~~13. A keyboard system comprising an array of keys wherein each key in the array is adapted to be assigned any one of a selection of available indicia at any given time, and a voice recognition system adapted to change the combinations of indicia assigned to the keys in the array whereby the combination of keys available to a keyboard operator may be changed as a result of a predetermined voice command.~~

14. A keyboard system comprising an array of keys wherein each key in the array is adapted to be assigned any ~~one of a selection of available indicia at any given time,~~



**SUBSTITUTE SHEET**

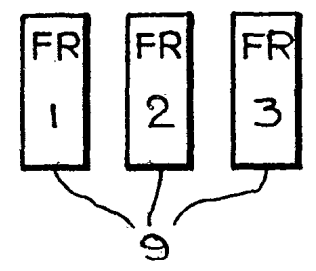
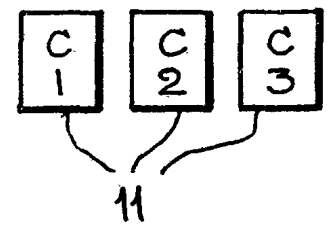
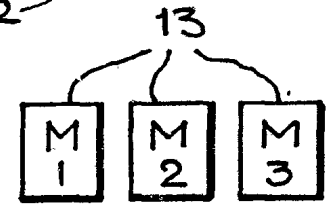
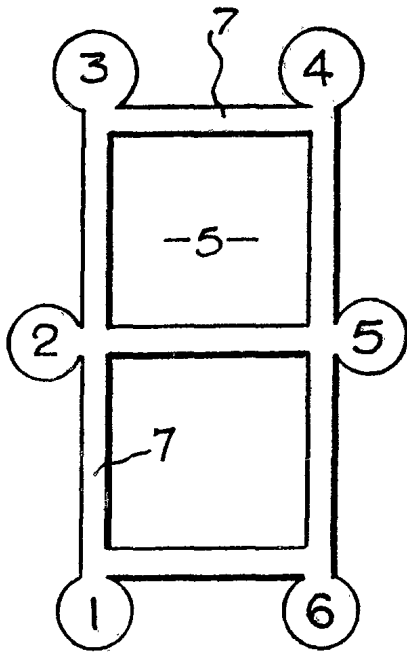
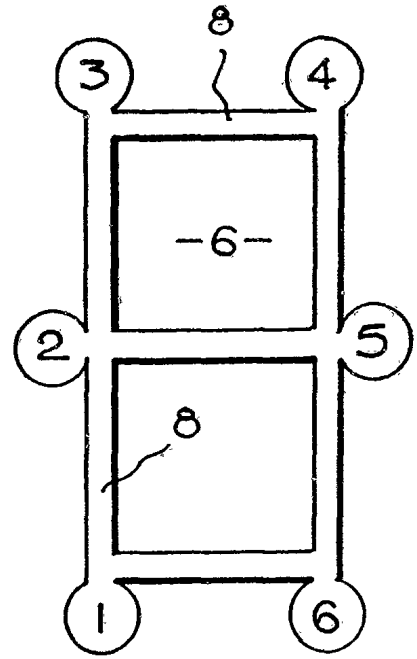
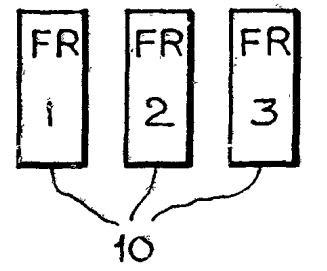
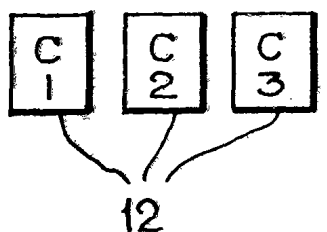
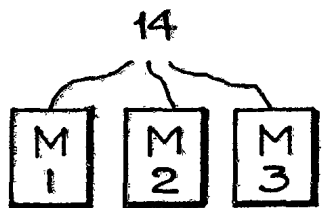
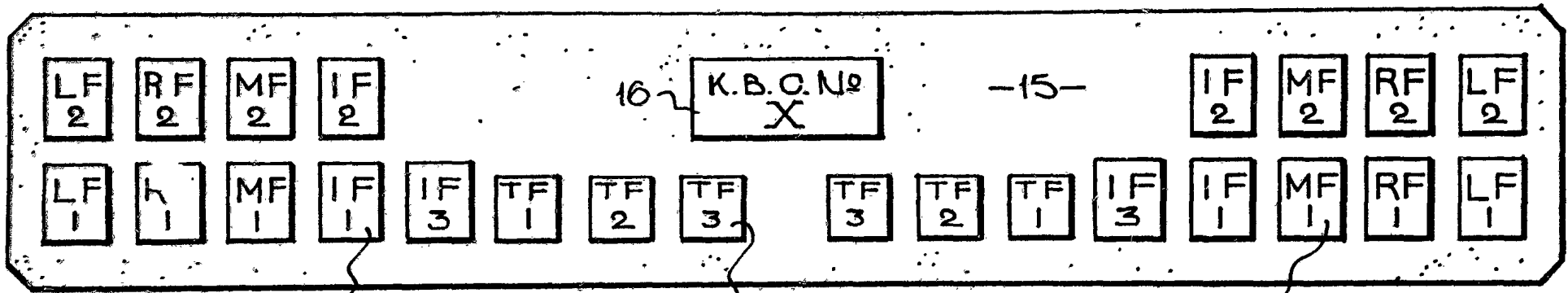

-FIG. 1-

1/3

23874/88

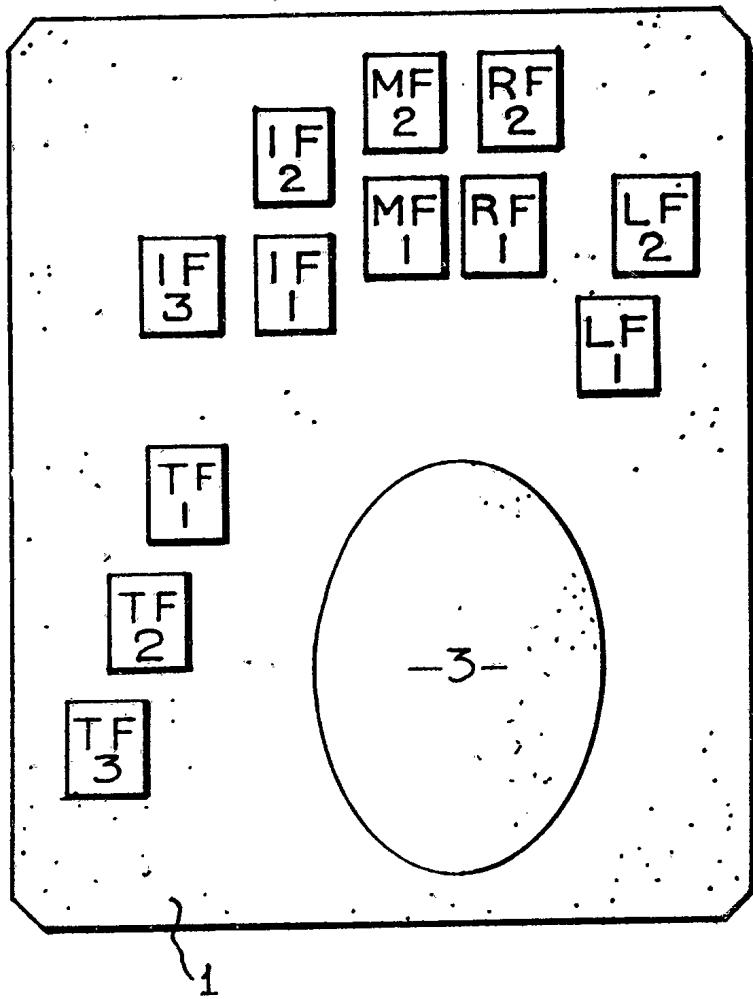
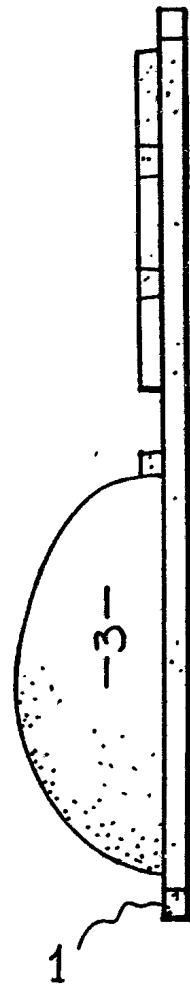

-FIG. 2-

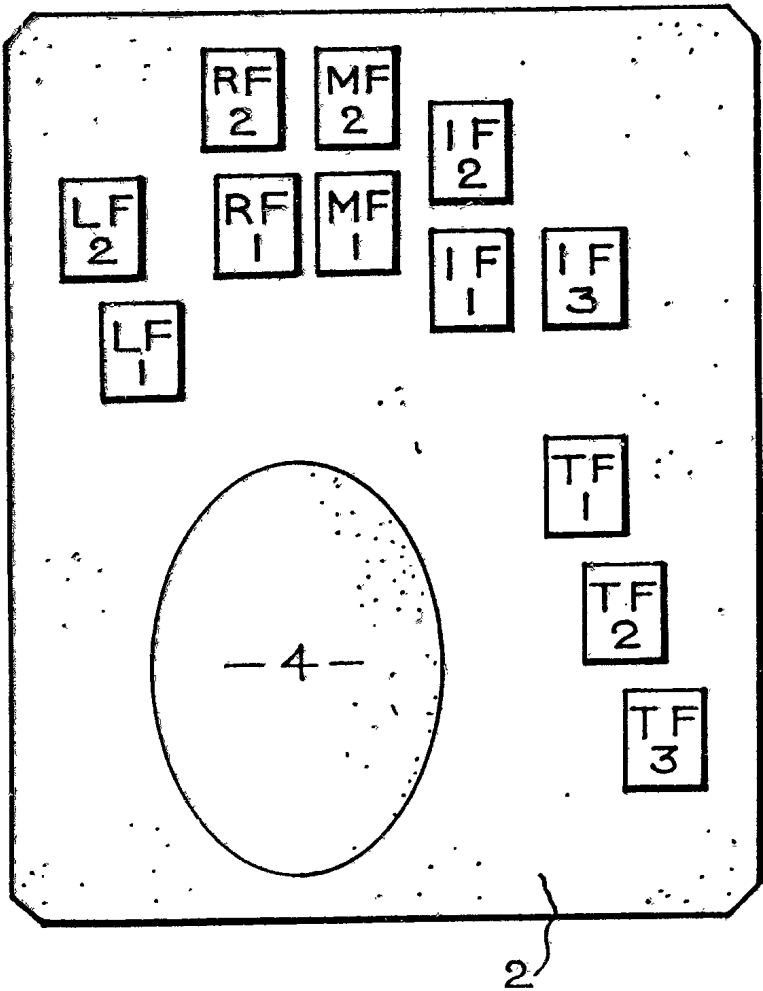



-FIG. 3-

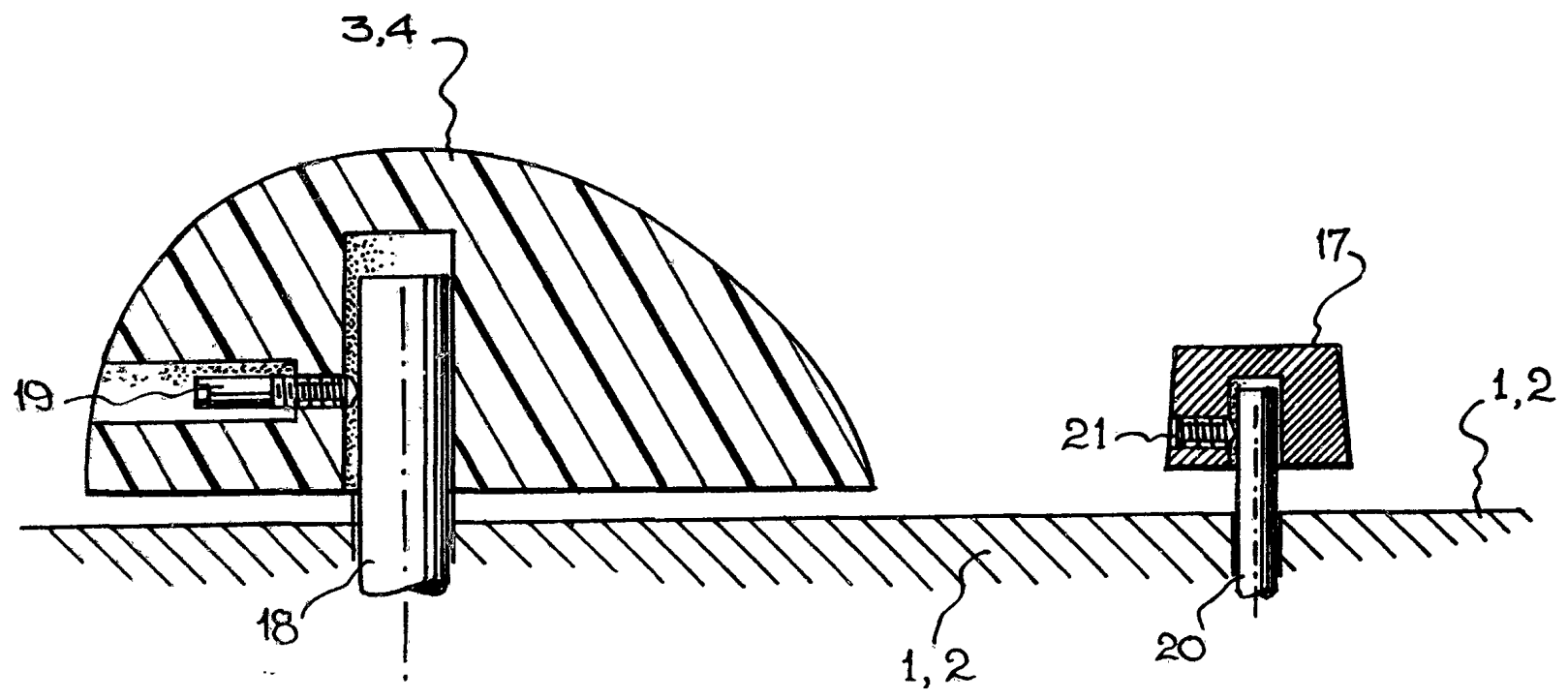

# INTERNATIONAL SEARCH REPORT

International Application No PCT/AU 88/00349

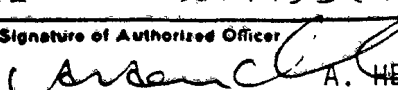
<b>I. CLASSIFICATION OF SUBJECT MATTER</b> (if several classification symbols apply, indicate all) <sup>4</sup>		
According to International Patent Classification (IPC) or to both National Classification and IPC		
Int. Cl. <sup>4</sup> B41J 5/08, H01H 13/70		
<b>II. FIELDS SEARCHED</b>		
Minimum Documentation Searched <sup>7</sup>		
Classification System	Classification Symbols	
IPC	B41J 5/08, 5/10, 5/28	
Documentation Searched other than Minimum Documentation to the extent that such Documents are included in the Fields Searched <sup>6</sup>		
AU : IPC as above and H01H 13/70		
<b>III. DOCUMENTS CONSIDERED TO BE RELEVANT <sup>8</sup></b>		
Category <sup>9</sup>	Citation of Document, <sup>10</sup> with indication, where appropriate, of the relevant passages <sup>11</sup>	Relevant to Claim No. <sup>12</sup>
P,X	EP,A2, 257490 (KAISER, T.) 2 March 1988 (02.03.88)	(1,2,10,11)
P,X	WO,A1, 88/00317 (CREWS, J.) 14 January 1988 (14.01.88)	(1,3,10,11)
P,X	GB,A, 2189195 (JIUN-YIH SUN) 21 October 1987. (21.10.87)	(1,2,10,11)
X,Y	US,A, 4669903 (HERZOG et al) 2 June 1987 (02.06.87)	(1)
X,Y	GB,A, 2181096 (P.C.D. MALTRON LTD) 15 April 1987 (15.04.87)	(1)
X,Y	FR,A1, 2587815 (BERNIER J.) 27 March 1987 (27.03.87)	(1-3,6,10,11)
X,Y	US,A, 4579470 (CASEY) 1 April 1986 (01.04.86)	(1)
X,Y	WO,A1, 85/03035 (LAHR R.J.) 18 July 1985 (18.07.85)	(1,2,10)
X,Y	EP,A2, 134160 (HOLDEN R.) 13 March 1985 (13.03.85)	(1-3,10)
X,Y	AU,B1, 27580/77 (CREATECHNIC PATENT AG) 8 February 1979 (08.02.79)	(1,3)
X,Y	US,A, 3945482 (EINBINDER) 23 March 1976 (23.03.76)	(1)
X,Y	DE,B, 1279693 (IBM DEUTSCHLAND) 10 October 1968 (10.10.68)	(1-3)
(continued)		
<p><sup>9</sup> Special categories of cited documents: <sup>10</sup></p> <p>"A" document defining the general state of the art which is not considered to be of particular relevance</p> <p>"E" earlier document but published on or after the international filing date</p> <p>"L" document which may throw doubts on priority claim(s) or which is cited to establish the publication date of another citation or other special reason (as specified)</p> <p>"O" document referring to an oral disclosure, use, exhibition or other means</p> <p>"P" document published prior to the international filing date but later than the priority date claimed</p> <p>"T" later document published after the international filing date or priority date and not in conflict with the application but cited to understand the principle or theory underlying the invention</p> <p>"X" document of particular relevance; the claimed invention cannot be considered novel or cannot be considered to involve an inventive step</p> <p>"Y" document of particular relevance; the claimed invention cannot be considered to involve an inventive step when the document is combined with one or more other such documents, such combination being obvious to a person skilled in the art.</p> <p>"Z" document member of the same patent family</p>		
<b>IV. CERTIFICATION</b>		
Date of the Actual Completion of the International Search	Date of Mailing of this International Search Report	
14 December 1988 (14.12.88)	22 DECEMBER 1988 (22.12.88)	
International Searching Authority	Signature of Authorized Officer	
Australian Patent Office	 A. HENDRICKSON	

## FURTHER INFORMATION CONTINUED FROM THE SECOND SHEET

Y

Patent Abstracts of Japan, M 33, page 64  
 JP,A, 55-91689 (SHINSHIYUU SEIKI K.K.) 11 July 1980  
 (11.07.80)

(6)

V.  OBSERVATIONS WHERE CERTAIN CLAIMS WERE FOUND UNSEARCHABLE \*

This international search report has not been established in respect of certain claims under Article 17(2) (a) for the following reasons:

1.  Claim numbers ..... because they relate to subject matter not required to be searched by this Authority, namely:
2.  Claim numbers ..... because they relate to parts of the international application that do not comply with the prescribed requirements to such an extent that no meaningful international search can be carried out, specifically:
3.  Claim numbers ..... because they are dependent claims and are not drafted in accordance with the second and third sentences of PCT Rule 6.4(a).

VI.  OBSERVATIONS WHERE UNITY OF INVENTION IS LACKING ?

This International Searching Authority found multiple inventions in this international application as follows:

1.  As all required additional search fees were timely paid by the applicant, this international search report covers all searchable claims of the international application.
2.  As only some of the required additional search fees were timely paid by the applicant, this international search report covers only those claims of the international application for which fees were paid, specifically claims:
3.  No required additional search fees were timely paid by the applicant. Consequently, this international search report is restricted to the invention first mentioned in the claims; it is covered by claim numbers:
4.  As all searchable claims could be searched without effort justifying an additional fee, the international searching authority did not invite payment of any additional fee.

Remark on Protest

- The additional search fees were accompanied by applicant's protest.
- No protest accompanied the payment of additional search fees.

ANNEX TO THE INTERNATIONAL SEARCH REPORT ON  
INTERNATIONAL APPLICATION NO. PCT/AU 88/00349

This Annex lists the known "A" publication level patent family members relating to the patent documents cited in the above-mentioned international search report. The Australian Patent Office is in no way liable for these particulars which are merely given for the purpose of information.

Patent Document Cited in Search Report	Patent Family Members		
WO 8800137	AU 78043/87		
AU 27580/77	BE 857424 CH 612625 IT 1086056 SE 7708846	BR 7705164 FR 2360427 JP 53044221 US 4081068	CA 1105113 GB 1579298 NL 7708666 US 4201489
GB 2181096	AU 60995/86	EP 219944	
WO 8503035	EP 168484	US 4661005	
EP 134160	US 4655621		
EP 257490	DE 3629417		

END OF ANNEX